

## Steni UK Limited

Units 1-4  
Vauxhall Industrial Estate  
Ruabon  
Wrexham LL14 6HA  
Tel: 01978 812111 Fax: 01978 810399  
e-mail: info@steni.co.uk  
website: www.steni.co.uk



Agrément Certificate  
**09/4662**  
Product Sheet 1

## STENI CLADDING PANELS

### STENI COLOUR T6/T7 RAINSCREEN CLADDING PANEL

#### PRODUCT SCOPE AND SUMMARY OF CERTIFICATE

This Certificate of Confirmation relates to Steni Colour T6/T7 Rainscreen Cladding Panel, a glassfibre-reinforced polymer composite board with a smooth acrylic surface finish. The product may be fixed to a timber or metal sub-frame to provide a protective/decorative cladding over the external walls of new or existing buildings. The sub-frame and its attachment to the substrate wall are outside the scope of this Certificate as are other miscellaneous construction details.

#### AGRÉMENT CERTIFICATION INCLUDES:

- factors relating to compliance with Building Regulations where applicable
- factors relating to additional non-regulatory information where applicable
- independently verified technical specification
- assessment criteria and technical investigations
- design considerations
- installation guidance
- regular surveillance of production
- formal three-yearly review.

#### KEY FACTORS ASSESSED

**Mechanical resistance and stability** — the product can be incorporated in a rainscreen cladding system suitably designed to resist the wind loads normally experienced in the UK (see section 5).

**Safety in case of fire** — the product can be incorporated in a construction meeting regulatory requirements (see section 6).

**Hygiene, health and the environment** — providing the joints between panels are adequately baffled, the cladding system incorporating the product will adequately protect the substrate wall (see section 7).

**Durability** — the product will have adequate durability (see section 9).



The BBA has awarded this Agrément Certificate to the company named above for the product described herein. This product has been assessed by the BBA as being fit for its intended use provided it is installed, used and maintained as set out in this Certificate.

On behalf of the British Board of Agrément

Date of First issue: 21 May 2009

Brian Chamberlain  
Head of Approvals — Engineering

Greg Cooper  
Chief Executive

*The BBA is a UKAS accredited certification body — Number 113. The schedule of the current scope of accreditation for product certification is available in pdf format via the UKAS link on the BBA website at [www.bbacerts.co.uk](http://www.bbacerts.co.uk)*

*Readers are advised to check the validity and latest issue number of this Agrément Certificate by either referring to the BBA website or contacting the BBA direct.*

British Board of Agrément  
Bucknalls Lane  
Garston, Watford  
Herts WD25 9BA

©2009

tel: 01923 665300  
fax: 01923 665301  
e-mail: [mail@bba.star.co.uk](mailto:mail@bba.star.co.uk)  
website: [www.bbacerts.co.uk](http://www.bbacerts.co.uk)

# Regulations

In the opinion of the BBA, Steni Colour T6/T7 Rainscreen Cladding Panel, if used in accordance with the provisions of this Certificate, will meet or contribute to meeting the relevant requirements of the following Building Regulations:



## The Building Regulations 2000 (as amended) (England and Wales)

Requirement:	A1	Loading
Comment:		The product is acceptable for use as set out in sections 5.1 to 5.10 of this Certificate.
Requirement:	B4(1)	External fire spread
Comment:		The product is judged to meet the Class 0 requirements. See sections 6.1 to 6.5 of this Certificate.
Requirement:	C2(b)(c)	Resistance to moisture
Comment:		The product will meet the stated requirements. See sections 7.1 to 7.4 of this Certificate.
Requirement:	Regulation 7	Materials and workmanship
Comment:		The product is acceptable. See section 9.2 and the <i>Installation</i> part of this Certificate.



## The Building (Scotland) Regulations 2004 (as amended)

Regulation:	8(1)	Fitness and durability of materials and workmanship
Comment:		The product can contribute to a construction satisfying this Regulation. See sections 8.1 to 8.3 and 9.2, and the <i>Installation</i> part of this Certificate.
Regulation:	9	Building standards – construction
Standard:	1.1(a)(b)	Structure
Comment:		The product is acceptable, with reference to clause 1.1.1 <sup>(1)(2)</sup> . See sections 5.1 to 5.10 of this Certificate.
Standard:	2.6	Spread to neighbouring buildings
Comment:		The product can contribute to satisfying this Standard, with reference to clause 2.6.4 <sup>(1)(2)</sup> . See sections 6.1 to 6.5 of this Certificate.
Standard:	2.7	Spread on external walls
Comment:		The product can contribute to satisfying this Standard, with reference to clause 2.7.1 <sup>(1)(2)</sup> . See sections 6.1 to 6.5 of this Certificate.
Standard:	3.10	Precipitation
Comment:		The product will contribute to meeting this Standard, with reference to clauses 3.10.1 <sup>(1)(2)</sup> to 3.10.3 <sup>(1)(2)</sup> . See sections 7.1 to 7.4 of this Certificate. (1) Technical Handbook (Domestic). (2) Technical Handbook (Non-Domestic).



## The Building Regulations (Northern Ireland) 2000 (as amended)

Regulation:	B2	Fitness of materials and workmanship
Comment:		The product is acceptable. See section 9.2 and the <i>Installation</i> part of this Certificate.
Regulation:	B3(2)	Suitability of certain materials
Comment:		The product is acceptable. See sections 8.1 to 8.3 of this Certificate
Regulation:	C4	Resistance to ground moisture and weather
Comment:		The product will contribute to meeting this Regulation. See sections 7.1 to 7.4 of this Certificate.
Regulation:	D1	Stability
Comment:		The product is acceptable as set out in sections 5.1 to 5.10 of this Certificate.
Regulation:	E5	External fire spread
Comment:		The product is judged to meet the Class 0 requirements. See sections 6.1 to 6.5 of this Certificate.

### Construction (Design and Management) Regulations 2007

### Construction (Design and Management) Regulations (Northern Ireland) 2007

Information in this Certificate may assist the client, CDM co-ordinator, designer and contractors to address their obligations under these Regulations.

See section: 8 *Maintenance and repair* (8.3).

## Non-regulatory Information

### NHBC Standards 2008

NHBC accepts the use of Steni Colour T6/T7 Rainscreen Cladding Panel, when installed and used in accordance with this Certificate, in relation to *NHBC Standard*, Chapter 6.9 – D8 *Rainscreen cladding*.

## General

This Certificate relates to Steni Colour T6/T7 Rainscreen Cladding Panel. The product may be fixed to a timber or metal sub-frame to provide a protective/decorative cladding over the external walls of new or existing buildings.

The sub-frame and its attachment to the substrate wall are outside the scope of this Certificate, as are other miscellaneous construction details.

It is important for designers, planners, contractors and/or installers to ensure that the installation of the cladding is in accordance with the Certificate holder's instructions and the information given in this Certificate.

This Certificate is a Confirmation of French Agréments Nos 2/08-1283 and 2/08-1284 issued by the CSTB<sup>(1)</sup> to Steni a.s.

(1) Centre Scientifique et Technique du Bâtiment.

## Technical Specification

### 1 Description

1.1 The panel is manufactured from a glassfibre-reinforced polymer composite board with a smooth acrylic finish applied using an electron beam curing process. It is produced in thicknesses of 5.5 mm and 6.5 mm, a width of 1195 mm and lengths from 850 mm to 3500 mm, and is available in 40 standard colours<sup>(1)</sup> and three gloss levels.

(1) Non-standard colours are available to special order.

1.2 The panel material has a mean dry density of 1880 kgm<sup>-3</sup> and water absorption of less than 2% in accordance with BS EN ISO 62 : 2008.

1.3 Attachment of the panels to the sub-frame is achieved by the use of stainless steel screws of grade A4 to BS EN ISO 3506-1 : 1998 (see Figure 1).

Figure 1 Details of fixing screws

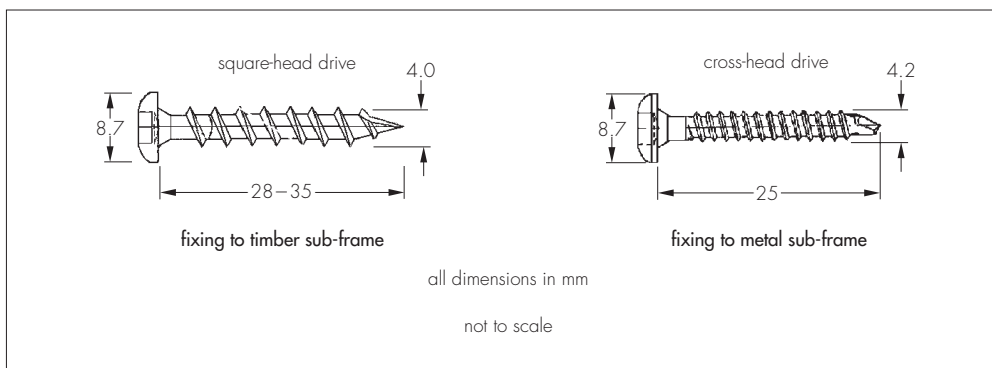

1.4 Product quality is maintained by self-inspections and verification testing by the CSTB. Checks are made on material composition and mechanical properties during manufacture and on the final product.

### 2 Delivery, storage and site handling

2.1 The panels are delivered to site shrink-wrapped onto pallets. The pallets bear product details including details such as type, size, quantity, identification code, manufacturing references and colour.

2.2 The pallets should be stored on a dry, flat and level surface suitably protected from the weather.

2.3 The panels should be handled with care to avoid damage. They should be lifted, rather than slid across, each other.

## Assessment and Technical Investigations

The following is a summary of the assessment and technical investigations carried out on Steni Colour T6/T7 Rainscreen Cladding Panel.

## 3 General

- 3.1 The panel can be incorporated in back-ventilated and drained cladding systems. The cavity behind the cladding should be as wide as possible, with a minimum ventilation area of 100 cm<sup>2</sup> per metre run of cladding (see section 7). The ventilation openings should be suitably protected, or baffled, to prevent the ingress of birds, vermin and rain.
- 3.2 The wall and the sub-frame to which the cladding is fixed should be structurally sound and constructed in accordance with the requirements of the relevant building regulations and national standards.
- 3.3 The wall to which the cladding is fixed should be watertight and resistant to the transmission of sound.
- 3.4 The insulation behind the cladding should be suitably fixed to the supporting wall, and protected, to resist the forces of wind suction. Insulation should be of a rigid type (eg boards or batts). The ventilation pathway behind the cladding must not be allowed to become blocked nor the insulation dislodged where it may be vulnerable to wetting.
- 3.5 To allow for expansion, the panels should be fixed to the sub-frame using the specified screw through close-tolerance holes at the middle and oversized holes of appropriate diameter at the edges of the panel.
- 3.6 A gap of 3 mm per metre length should be provided between adjacent panels. The panels should not straddle any gaps provided for expansion between sub-frame members.
- 3.7 All design aspects of the installation should be checked by a suitably qualified engineer.

## 4 Practicability of installation

The products should only be installed by installers who have been trained and approved by the Certificate holder.

## 5 Mechanical resistance and stability

### Wind loading



5.1 The substrate wall to which the cladding is to be fixed should be constructed in accordance with the requirements of the relevant building regulations and standards.

- 5.2 The supporting wall must be able to resist the full wind as well as any racking loads on its own. No contribution from the cladding may be assumed in this regard.
- 5.3 Wind loads should be calculated in accordance with BS EN 1991-1-4 : 2005 or BS 6399-2 : 1997.
- 5.4 When calculating wind loads at corners, higher pressure coefficients, as recommended in the appropriate Standards, should be used.
- 5.5 The design of the sub-frame and its attachment to the substrate wall should be in accordance with the relevant Codes and Standards (not covered by this Certificate), and should be such as to limit mid-span deflections to  $L/200$  and cantilever deflections to  $L/150$ .
- 5.6 The details of the fasteners for fixing the panel to the sub-frame are shown in Figure 1. For details of the fixing suppliers, the Certificate holder should be consulted. The fixing-to-panel-edge distance should not be less than 12 mm.
- 5.7 The allowable wind pressures (positive or negative) for two nominal support spacings and three fixing centres are presented in Tables 1 and 2.

Table 1 Allowable wind pressures (Pa) — Installation to timber sub-frame

Panel <sup>(1)</sup> orientation	600 mm support spacing fixing centres (mm)			400 mm support spacing fixing centres (mm)		
	300	250	200	300	250	200
Vertical	1400	1700	2100	2300	2800	3500
Horizontal	1550	1850	2350	2850	3100	3550

(1) Nominal size 1200 mm x 2400 mm.

Table 2 Allowable wind pressures (Pa) – Installation to metal sub-frame

Fixing layout <sup>(1)</sup> V x H	600 mm support spacing fixing centres (mm)			400 mm support spacing fixing centres (mm)		
	300	250	200	300	250	200
2 x 2	930	1090	1340	1390	1640	2010
3 x 2 n x 2	1030	1220	1360	1540	1830	2260
2 x 3 2 x n	990	1170	1430	1480	1750	2140
3 x 3 n x n	1140	1370	1435	1640	1960	2420

(1) V = vertical, H = horizontal, n = number of fixings ≥ 3.

5.8 For design purposes, the following panel mechanical properties may be assumed:

allowable flexural stress (Nmm <sup>-2</sup> )	10
flexural modulus (Nmm <sup>-2</sup> )	5000
allowable fixing pull-through value (N):	
– middle	320
– edge	100
– corner	45.

5.9 The design of the installation should be checked by a suitably qualified engineer.

### Impact

5.10 A sample of the product supported on battens at 600 mm centres, when tested for impact, was found to adequately resist a 'soft body' impact energy of greater than 500 Nm and a 'hard body' impact energy of greater than 10 Nm. Therefore, the product may be considered suitable for use in location categories B to F, as defined in BS 8200 : 1985, Table 2.

## 6 Safety in case of fire



6.1 Samples of the panel, when tested for reaction to fire, achieved a classification of B-s1, d0 in accordance with the BS EN 13501-1 : 2007.

6.2 The product may be regarded as having a Class 0 surface ('low risk' material in Scotland) in accordance with the following national Building Regulations. The unexposed side of the panel may also be regarded as having a Class 0 surface:

**England and Wales** — Approved Document B

**Scotland** — Technical Handbooks<sup>(1)(2)</sup>, Section 2

(1) Technical Handbook (Domestic).

(2) Technical Handbook (Non-Domestic).

**Northern Ireland** — Technical Booklet E.

6.3 For resistance to fire, the performance of a wall incorporating the rainscreen can only be determined by tests from a suitably accredited laboratory and is not covered by this Certificate.

6.4 The incorporation of combustible material behind the cladding should be avoided wherever possible; any insulation should be non-combustible.

6.5 Cavity barriers should be incorporated behind the cladding, as required under the national Building Regulations, but should not block essential ventilation and drainage pathways.

## 7 Hygiene, health and the environment



7.1 The product is suitable for use in back-ventilated and drained rainscreen cladding systems.

7.2 The supporting wall must be watertight and reasonably airtight.

7.3 Providing the joints between the panels are adequately baffled, the amount of water entering the cavity by wind-driven rain will be minimal. Any water collecting in the cavity due to rain or condensation will be removed by drainage and ventilation.

7.4 The air space between the back of the boards and the supporting wall or insulation should be as wide as possible and should allow for conventional building tolerances. Guidance on recommended cavity widths is given in *NHBC Standards*, Chapter 6.9.

## 8 Maintenance and repair



8.1 For normal soiling, the surface may be cleaned using hot water/household detergent, applied with a suitable cleaning pad or sponge. Abrasive cleaners should not be used. For more difficult chemical soiling, the manufacturer's specialist advice should be sought.

8.2 Annual maintenance inspections should be carried out to ensure that rainware is complete and in good order and that such features as tiles, flashings and seals are in place and secure.

8.3 Damaged panels should be replaced as soon as is practicable, following the manufacturer's instructions and observing all necessary health and safety regulations.

## 9 Durability

9.1 The durability and service life of a cladding system incorporating the product will depend upon the building location, façade aspect, immediate environment, intended use of the building and general condition of the system components.



9.2 Due to its thickness, the panel's surface finish can be expected to provide adequate protection to the panel for approximately 30 years.

9.3 In general, there will be a colour change and dulling of the surface. However, this is not likely to be excessive or progressive and will be uniform on any one elevation.

## Installation

### 10 General

10.1 Steni Colour T6/T7 Rainscreen Cladding Panels must be installed in accordance with the manufacturer's recommendations, the requirements of this Certificate and specifications laid down by the consulting engineer.

10.2 Installers must be trained and approved by the Certificate holder who can provide technical assistance at the design stage and at the start of the installation.

10.3 If significant colour variations between batches is likely, it may be necessary to mix the boards from different pallets so as to obtain a uniform shade over the façade.

### 11 Procedure

11.1 Based upon the architectural and design details, a grid layout is first prepared and the cladding support system installed (not covered by this Certificate). Accurate grid positioning and installation of the support system is essential.

11.2 Depending on the cladding system and degree of exposure, a vapour permeable membrane may be required to protect the substrate wall or insulation.

11.3 Working from the bottom upwards, the boards are fixed to the vertical supports using the specified screws at the centres determined by design (see section 5).

## Technical Investigations

### 12 Investigations

12.1 Based on the French Technical Approvals, an assessment was made of the product's wind loading resistance, durability, the production method and associated quality control procedures.

12.2 From test data, an assessment was made of the product's impact resistance and behaviour in relation to fire.

12.3 Based on a user survey, an assessment was made of the product's practicability of installation and its performance in use.

12.4 The Certificate holder's technical literature was examined for inconsistencies and general content.

## Bibliography

BS 6399-2 : 1997 *Loading for buildings — Code of practice for wind loads*

BS 8200 : 1985 *Code of practice for design of non-loadbearing external vertical enclosures of buildings*

BS EN 1991-1-4 : 2005 *Eurocode 1 : Actions on structures — General actions — Wind actions*

BS EN 13501-1 : 2007 *Fire classification of construction products and building elements. Classification using test data from reaction to fire tests*

BS EN ISO 62 : 2008 *Plastics — Determination of water absorption*

BS EN ISO 3506-1 : 1998 *Mechanical properties of corrosion-resistant stainless steel fasteners — Bolts, screws and studs*

## 13 Conditions

13.1 This Certificate:

- relates only to the product/system that is named and described on the front page
- is granted only to the company, firm or person named on the front page — no other company, firm or person may hold or claim any entitlement to this Certificate
- is valid only within the UK
- has to be read, considered and used as a whole document — it may be misleading and will be incomplete to be selective
- is copyright of the BBA
- is subject to English law.

13.2 Publications and documents referred to in this Certificate are those that the BBA deems to be relevant at the date of issue or re-issue of this Certificate and include any: Act of Parliament; Statutory Instrument; Directive; Regulation; British, European or International Standard; Code of Practice; manufacturers' instructions; or any other publication or document similar or related to the aforementioned.

13.3 This Certificate will remain valid for an unlimited period provided that the product/system and the manufacture and/or fabrication including all related and relevant processes thereof:

- are maintained at or above the levels which have been assessed and found to be satisfactory by the BBA
- remain covered by a valid French Agrément; and
- are reviewed by the BBA as and when it considers appropriate.

13.4 In granting this Certificate, the BBA is not responsible for:

- the presence or absence of any patent, intellectual property or similar rights subsisting in the product/system or any other product/system
- the right of the Certificate holder to manufacture, supply, install, maintain or market the product/system
- individual installations of the product/system, including the nature, design, methods and workmanship of or related to the installation
- the actual works in which the product/system is installed, used and maintained, including the nature, design, methods and workmanship of such works.

13.5 Any information relating to the manufacture, supply, installation, use and maintenance of this product/system which is contained or referred to in this Certificate is the minimum required to be met when the product/system is manufactured, supplied, installed, used and maintained. It does not purport in any way to restate the requirements of the Health & Safety at Work etc Act 1974, or of any other statutory, common law or other duty which may exist at the date of this Certificate; nor is conformity with such information to be taken as satisfying the requirements of the 1974 Act or of any statutory, common law or other duty of care. In granting this Certificate, the BBA does not accept responsibility to any person or body for any loss or damage, including personal injury, arising as a direct or indirect result of the manufacture, supply, installation, use and maintenance of this product/system.

