



Features & Benefits

- Volume or velocity reduction
- Suitable for supply & extract systems
- Minimum and maximum speed adjustment
- 2 or 3-wire fan speed connections
- Quiet operation
- Flow rate reduction on centrifugal pumps

Technical Overview

The FC-ERV series of electronic speed controllers provide an economic means of regulation for voltage controllable single-phase AC motors. Centrifugal fans, axial fans, propeller fans, and centrifugal pumps are prime candidates for electronic speed control.

Fan speed is controlled via a remote 0-10Vdc or 0-20mA signal, suitable for direct connection to BEMS or transmitters.

It is equipped with Modbus RTU communication and provides a wide range of functionalities: remote control options, adjustable off level, min. and max. output voltage settings, and time-limited motor operation initiated by a logic or switch signal.

Product Codes		Specification	
FC-ERV1	Electronic speed controller 1A	Nominal Supply	230Vac/1Ph/50Hz
FC-ERV3	Electronic speed controller 3A	Control type	0-10Vdc or 0-20mA Modbus RTU
FC-ERV5	Electronic speed controller 5A	On/Off switch	Mounted on side
FC-ERV10	Electronic speed controller 10A	Input signal:	0-20mA @ 250Ω 0-10Vdc @ 90KΩ
		Starting sequence:	
		Kick start	Max. speed for 10 sec, then motor speed is as input signal
		No kick start	Motor speed is as input signal
		Speed adjustment:	
		Minimum	69-161V
		Maximum	175-230V
		Off level	0-4V or 10-6V (adjustable by potentiometer)
		Current ratings (nominal):	
		FC-ERV1	1.5A
		FC-ERV3	3.0A
		FC-ERV5	6.0A
		FC-ERV10	10.0A
		Fuse ratings:	
		FC-ERV1	F 3.15 A-H
		FC-ERV3	F 5.0 A-H
		FC-ERV5	F 10.0 A-H
		FC-ERV10	F 16.0 A-H
		Mounting style	Wall mount
		Dimensions	178 x 113 x 92mm
		Protection category	IP54
		Ambient:	
		Temperature	20 to 40°C
		RH	<95% non-condensing
		Country of origin	Belgium
			
		The products referred to in this data sheet meet the requirements of EU 2014/30/EU and 2014/35/EU	

WEEE Directive:



At the end of the products useful life please dispose as per the local regulations.
Do not dispose of with normal household waste.
Do not burn.

Motor Compatibility

Speed controllers can only be connected to motors having appropriate characteristics. Motors must be voltage controllable, asynchronous, squirrel caged, Class 'F' wound, direct driven, with standard or external, high resistance rotors. They should be air cooled with a frame size sufficient to dissipate the additional heat generated when running at low speed/low airflow. It is recommended that motors have internal thermal protection.

Speed controllers operate most efficiently with conventional split capacitor or shaded pole motors. Six or eight pole motors are suitable but four pole motors are preferred as they have a greater control range. Two pole motors can be used but are difficult to control at low speeds (below 600 rpm) and can cause start-up problems at low voltages.

If there is any doubt regarding a motor's compatibility with electronic speed controllers, contact the fan or motor manufacturer for guidance.

Selection Criteria

Motors must be well loaded for optimum speed control, so choose one that is just big enough for the application. The motor load must be at least 75% of the nominal power of the motor at maximum speed. Choose a speed controller with a maximum current that is just larger than the nominal motor running current, i.e. if motor rating is 2.95 amps, select a controller with a maximum current of 3 amps.

Several motors can be connected to one speed controller, so long as the controller's maximum current is not exceeded. Although rare, some motors can have a higher current consumption, when run at lower voltages, than the motor's nominal current at design voltage. The highest current should be used when selecting the speed controller.

Nominal Current Range

The speed controller Nominal Current Range refers to the nominal current rating of the motor and is based on a maximum ambient of 30°C. The speed controllers will accept a motor starting current that is up to 3 x greater than the maximum nominal current of the speed controller.

Starting Sequence

The starting sequence describes what happens when first switching on and also when power is reapplied. The FC-ERV start-up mode is selected by dipswitch.

Kick start.

Full voltage is initially applied to the motor for 10 seconds to overcome friction and back-draught. After 10 seconds the motor speed will automatically follow the position set by the 0-10Vdc or 0-20mA control signal.

Without kick (soft) start.

The motor will start according to the position set by the 0-10Vdc or 0-20mA control signal.

Fused Isolator & Maintenance

It is recommended that a fused mains isolator is installed upstream of the speed controller. The fuses should be of the slow blow type with a current rating that is the same as the speed controller's internal fast blow fuse.

In normal use, the speed controllers are maintenance free. If the fuse blows, it should only be replaced with a new fuse of the correct size and rating.

To remove light dirt and grime, wipe surfaces with a dry or slightly damp cloth. To remove heavy dirt and grime, use a proprietary non-aggressive cleaning agent. In all cases, ensure that the unit is completely dry prior to reconnecting the power supply.

Operational Diagrams

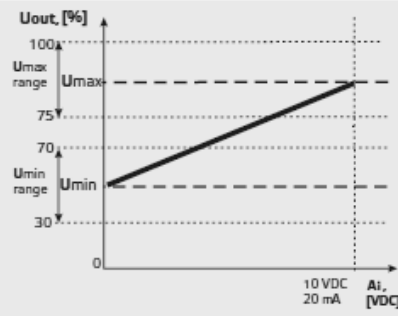
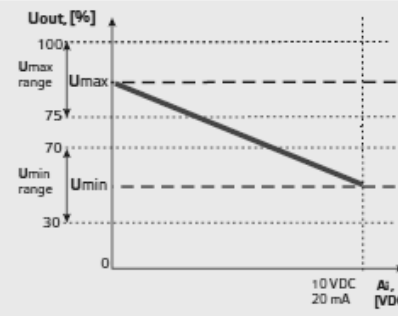
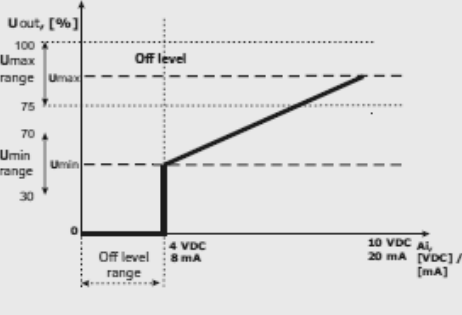
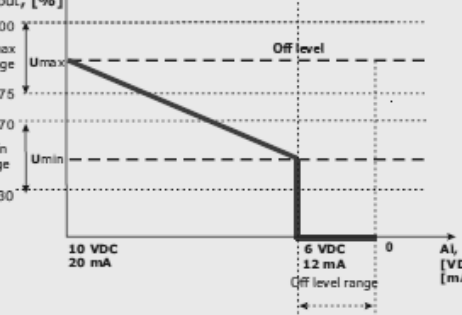
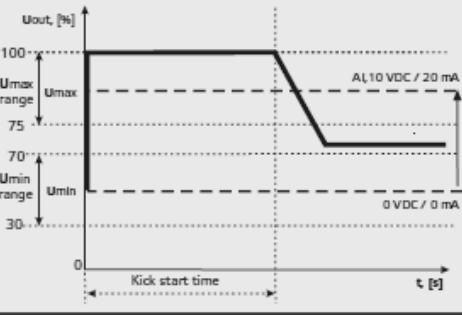
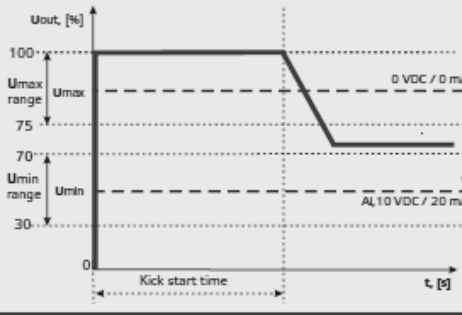
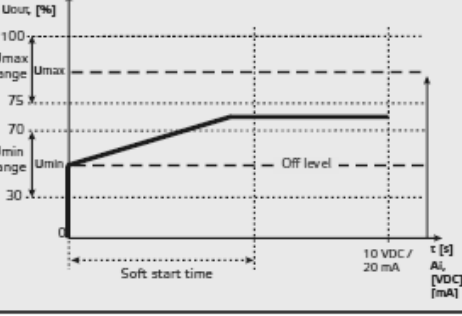
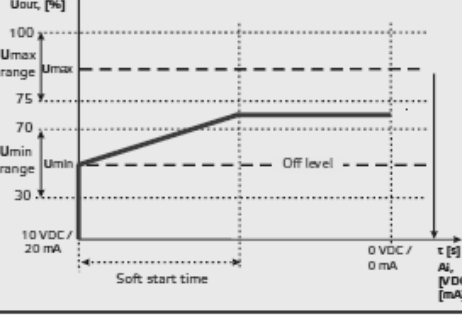
Normal / Remote operating modes		
<p>Ascending input mode</p> 	<p>Descending input mode</p> 	Off level disabled
<p>Ascending mode calculation formula</p> $U_{out} = U_{min} + \frac{A_i}{A_{i_{max}}} (U_{max} - U_{min})$	<p>Descending mode calculation formula</p> $U_{out} = U_{max} - \frac{A_i}{A_{i_{max}}} (U_{max} - U_{min})$	
		Off level enabled
<p>Ascending mode calculation formula</p> $U_{out} = U_{max} + \frac{A_i - \text{Off level}}{A_{i_{max}} - \text{Off level}} (U_{max} - U_{min})$	<p>Descending mode calculation formula</p> $U_{out} = U_{max} - \frac{A_i - \text{Off level}}{A_{i_{max}} - \text{Off level}} (U_{max} - U_{min})$	
		Kick start enabled
		

Operational Diagrams

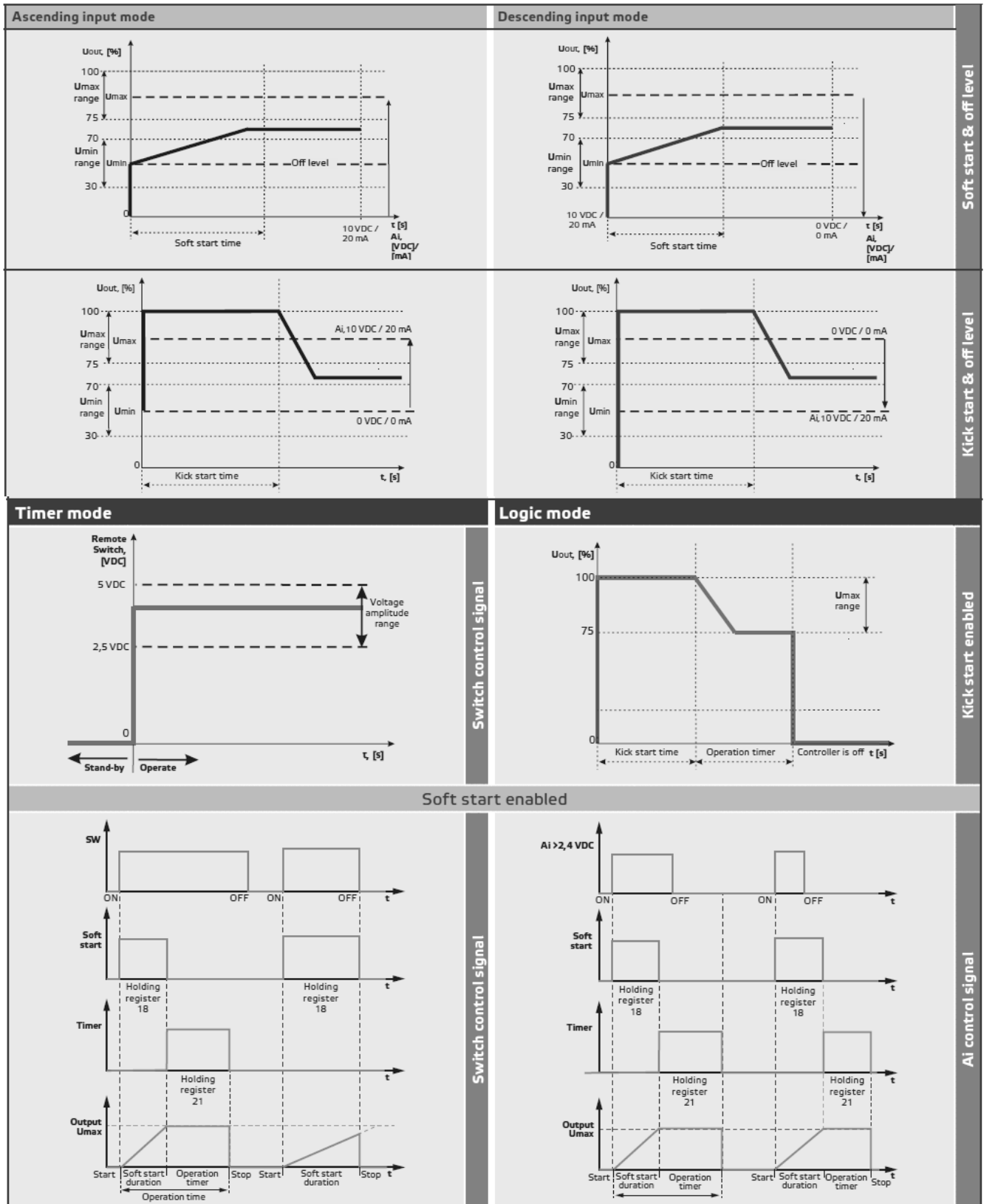

Installation

1. The FC-ERV should only be installed by a competent, suitably trained technician, experienced in installation with hazardous voltages. (>50Vac & <1000Vac or >75Vdc & 1500Vdc)
2. Ensure that all power is disconnected before carrying out any work on the FC-ERV.
3. Maximum cable is 2.5mm², care must be taken not to over tighten terminals.
4. Undo the four retaining screws that secure the housing lid. Remove the lid which can then be put aside. Take care not to lose the fixing screws.
5. Fix the housing to a suitable flat surface, using the four fixing screws and raw plugs provided.
6. Feed the cable through the waterproof gland and terminate the cores at the terminal blocks. Leaving some slack inside the unit, tighten the cable gland onto the cable to ensure watertightness.
7. Set positions of dipswitches and potentiometers for application. Replace lid, tighten the four lid fixing screws.
8. Switch the power on to the controller and check correct operation.

Front panel LED indication

When the green LED on the front cover gives out a continuous light, the controller operates in normal mode. When it blinks:

- The controller operates in remote control mode, or
- OFF level is enabled and the analogue input signal is below the OFF level value.

Connections

2-wire motor:

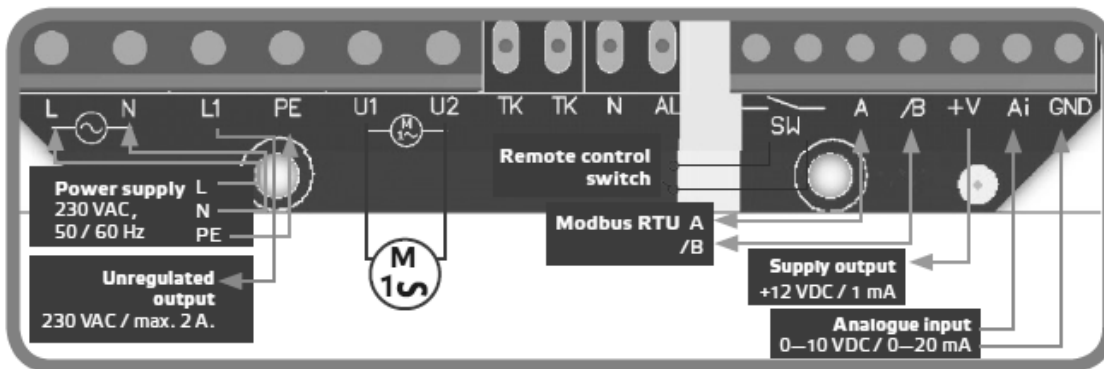

3-wire motor:

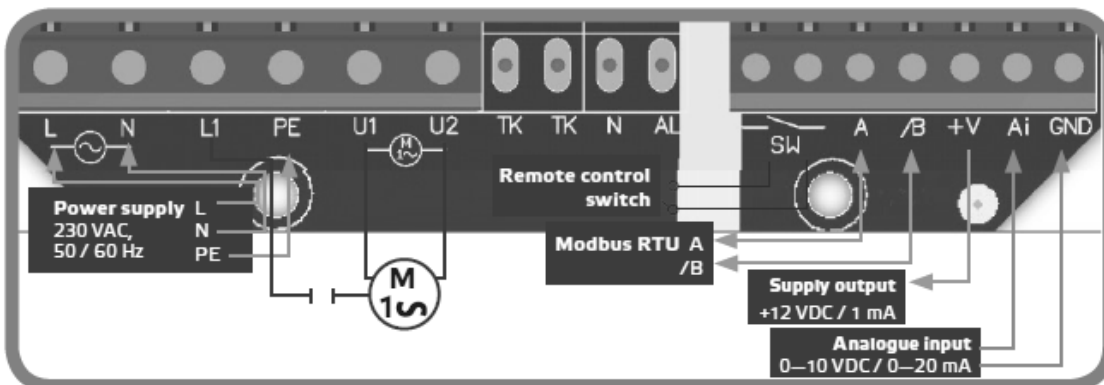

DIP-switch Settings

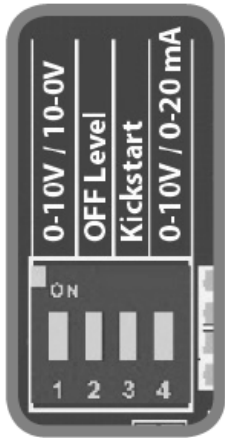

Ascending / descending mode selection (DIP switch, position 1)		ON - Descending mode: 10–0 VDC / 20–0 mA OFF - Ascending mode: 0–10 VDC / 0–20 mA
OFF level selection (DIP switch, position 2)		ON - enabled OFF - disabled
Kick start / soft start selection (DIP switch, position 3)		ON - Kick start OFF - Soft start
Input mode selection (DIP switch, position 4)		ON - Current mode (0–20 mA) OFF - Voltage mode (0–10 VDC)

Potentiometers

Maximum speed Default setting is U_s (230Vac)



Minimum speed Default setting is 30% U_s (69Vac)



OFF level Default setting is 0Vac



Whilst every effort has been made to ensure the accuracy of this specification, Sontay cannot accept responsibility for damage, injury, loss or expense from errors or omissions. In the interest of technical improvement, this specification may be altered without notice.

Tel: +44 (0)1732 861200 - E-mail: sales@sontay.com - Web: www.sontay.com

© 2017 Sontay Limited. All rights reserved