

Free Hanging Panels

Application: Open ceiling environments

Suitable for workshops, sports halls or any open ceiling environment, Solray Free Hanging ("FH") panels are highly flexible in terms of shape and size.

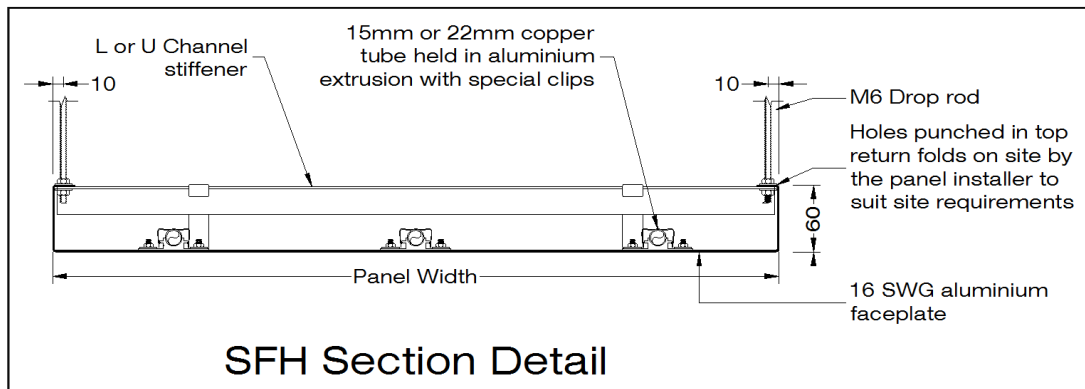

Aesthetically pleasing and available with ball or shuttlecock guards for sports environments, the Solray FH Panel is an ideal solution for large volume spaces where conventional warm air convection heating systems would be ineffective or uneconomic.



Available in our standard 1.6mm aluminium, 2mm perforated aluminium (for improved acoustic properties) or 2mm steel for areas where an anti-vandal panel is required. Solray FH panels are extremely robust and ideally suited to sports halls where ball games are likely to be played or where other impacts are possible.

FH Panels can be customised for lengths, widths and outputs and can therefore be adapted to suit any situation. All Solray panels can be manufactured to accept integrated lighting and other services.

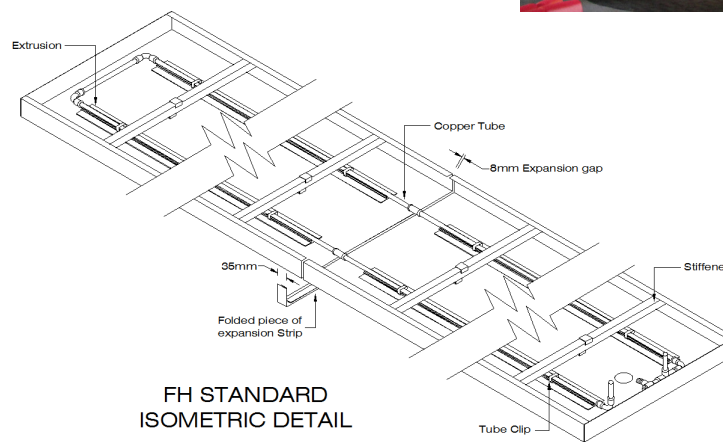

Solray Standard FH Technical Specification

- 1.6mm smooth aluminium faceplates, free of any ridges and lines
- Factory finished in a white texture to RAL 9010 (other colours can be provided)
- Waterways are copper tubes sized to minimise pressure drops while maintaining turbulent flow through all tubes. The minimum pipe diameter is 15mm to prevent the tubes blocking
- All factory assembled grids are tested to 7 bar, for system working pressures of 3.5 bar. Solray panels can be tested to higher pressures if required
- A drain cock, with an optional plugged hose access hole, is included as standard at all low points
- A discreet expansion strip covers the joints between panels to allow and conceal expansion
- Panels have stiffeners to prevent panel bowing and to provide support positions
- Insulated with 50mm foil backed unencapsulated glass fibre with a thermal conductivity at 70°C of 0.045 W/m K
- Panel mass:
 - 1 tube / 150-300mm wide panels 3.7kg/m max
 - 2 tube / 350-600mm wide panels 7.0kg/m max
 - 3 tube / 650-900mm wide panels 10.3kg/m max
 - 4 tube / 950-1200mm wide panels 13.4kg/m max
- The outputs of Solray Panels have been tested to BS EN 14037.