



SAMSUNG

Differentiate your business with brilliant, high-impact images

Samsung has taken its expertise in visual displays and has applied it to its new lineup of LED Large Format Displays (LFD). These LFDs leverage the most cutting-edge technology and offer the latest in advanced features available today. Featuring all the advantages of LED backlighting, the Samsung ME Series produces crisp images with accurate color representation, which is extremely critical when displaying large format content. Looking beyond the display, the Samsung ME Series delivers a business solution that is aligned with your business needs. For starters, the ME Series consumes less energy than conventional large format displays built with CCFL technology. The ME Series is also environmentally friendly to complement your business's green strategy. And the slimmer and light-weight design enables a more efficient use of space and allows the ME Series to be configured based on the application, not the other way around.



ME Series

Display Type	46"
Resolution	1920 x 1080 (16:9)
Inch Option	40/46/55
Key Features	Eco Friendly
	Slim & Light
	Built in Contents Player

* Please visit the website to verify detail specifications

Key Features



Slim & Light Weight

Build a viewing environment with higher impact
The slim and lightweight design of the Samsung ME Series delivers a flexible and more customizable solution to better suit your business needs. The ME Series is 77% thinner than large format displays that use CCFL, allowing you to create more space between the LFD and viewer. The lightweight design also enables easier installation and a wider range of applications with less support materials.



Low Power & Eco Friendly

Cut operational costs while protecting the environment
Identifying gaps in operational processes is a critical aspect of running a profitable business. The Samsung ME Series can help to close some of those gaps by delivering a cost-effective solution that's also gentle on the planet. The LED technology driving the LFD consumes less energy than conventional CCFL-based large format displays and is lower on CO2 emissions.

Built-in Contents Player

Add variety and flexibility to the content you display
The Samsung ME Series are designed with a built-in content player for greater display capabilities. So in addition to the content on the built-in player, the ME Series can display content from MagicInfo-i Lite, videos, images, music and even documents like PPT files. Since the ME Series already comes equipped with a content player, there's no need to purchase additional software or equipment, or even a PC connection.



Specification

		ME46A	
Display Type	Size	46"	
	Resolution	1920 x 1080 (16:9)	
	Contrast Ratio	5000:1	
	Active Area	1036.08 x 591.30mm	
Electrical	Power	Type	Internal AC100~240V, 50/60Hz
		Max	160W
	Power Consumption	Type	140W
		Sleep Mode	less than 1W
		Off Mode	less than 1W
Mechanical	Dimension	Set	1056.3 x 612.3 x 29.9mm
		Package	1170.0 x 730.0 x 199.0mm
	Weight	Set	12.5kg
		Package	16.6kg
VESA	400 x 400mm		

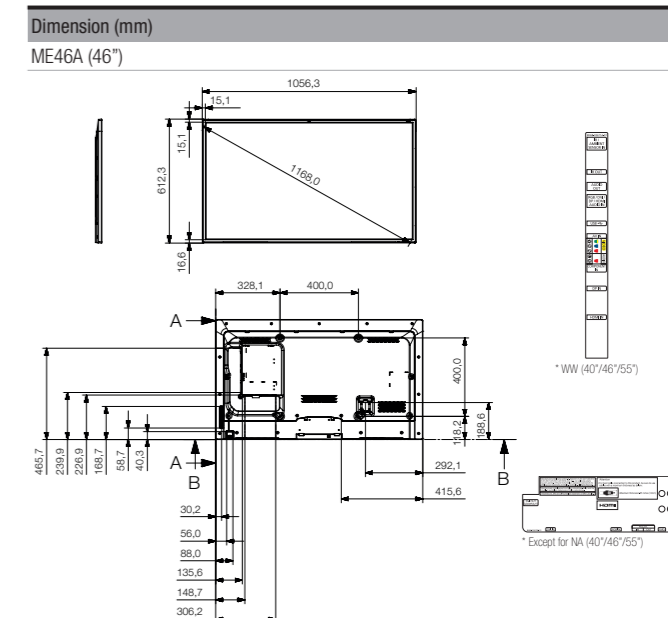

* This dimension is applicable to ME55A.

SAMSUNG



Deliver the benefits of a large format display to your business

Built using the industry-standard CCFL technology, the Samsung CCFL Large Format Display (LFD) lineup provides a solid and reliable solution to meet your large format display needs. The DX Series produces superior picture quality with a higher contrast ratio and superb image brightness. The result is a display that creates vibrant and highly visible images that's also extremely cost efficient due to low maintenance and strong reliability. To provide you with even greater convenience and versatility, the Samsung DX Series is built with a wide range of connectivity features. The display is also much lighter and thinner than the competition so shipping and installation is easier and less costly. Plus, the built-in speakers allow you to complement your video message with audio without having to purchase additional equipment and figuring out how and where to install them.



DX Series

Display Type	46"
Resolution	1920 x 1080 (16:9)
Inch Option	40/46/55/70/82
Key Features	High Reliability
	Best Picture Quality
	High Performance

* Please visit the website to verify detail specifications

Key Features

Best Picture Quality

Communicate your message in a bright new way. As one of the brightest displays on the market today, Samsung DX Series is a high-impact display that will give your message the attention it deserves. Built with the same industry-leading imaging technology Samsung uses with its TVs, such as superior brightness levels, the DX Series produces images that are more vibrant and realistic than any other large format display in its class.



Various Connectivity

Expand the variety of content you deliver to your audience. The Samsung DX Series enables businesses to access a wider range of digital content for a more immersive and engaging user experience with its comprehensive connectivity options. With the DX Series, you have the ability to connect PCs and other compatible digital devices to display the content that's most relevant for your audience. The Slide in Module (SIM) design allows for customers with various needs to customize their content based on local demand. In addition, MagicInfo-i helps to streamline content management from almost any location.



Specification

		460DX-3	
Display Type	Size	46"	
	Resolution	1920 x 1080 (16:9)	
	Contrast Ratio	3000:1	
	Active Area	1018.08 x 572.67mm	
Electrical	Power	Type	Internal AC100~240V, 50/60Hz
		Power Consumption	Max 250W
		Type	230W
		Sleep Mode	less than 2W
		Off Mode	less than 1W
Mechanical	Dimension	Set	1068.0 x 624.0 x 130.0mm
		Package	1190.0 x 755.0 x 315.0mm
	Weight	Set	21.2kg
		Package	25.7kg
	VESA	600 x 400mm	

24-hour Reliability

Leverage the benefits of greater reliability. The Samsung DX Series offers enhanced operational reliability for greater peace of mind. The Samsung DX Series utilizes innovative cooling technologies to improve heat dissipation while lowering internal temperatures. That allows the LFD to operate efficiently and consistently over longer periods of time without costly servicing or maintenance.



More Standard Features

Benefit from more standard features and accessories. Unlike its competition, the Samsung DX Series boasts a slim and light-weight design. That allows for greater flexibility and opens up a whole new world of options for customized installation applications. The DX Series also offers a wider range of proprietary features that comes standard like built-in speakers and digital out port, than any other models in its class. Plus, the DX Series' size and weight facilitates easier installation for almost anyone.

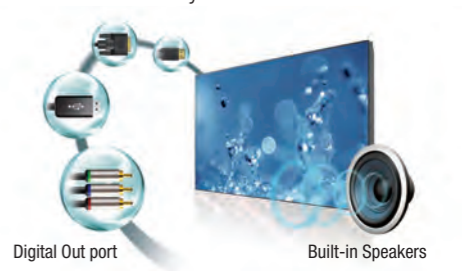

Dimension (mm)	
460DX (46")	

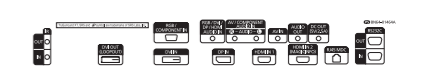
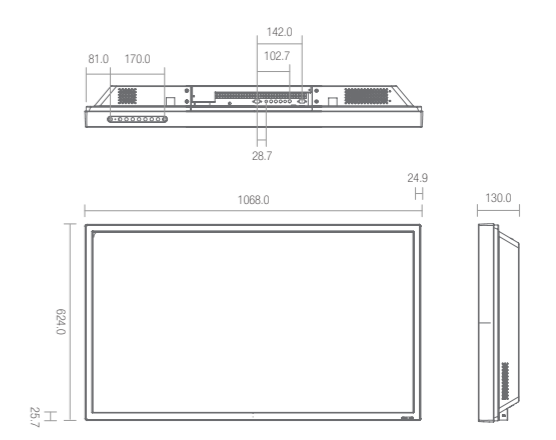

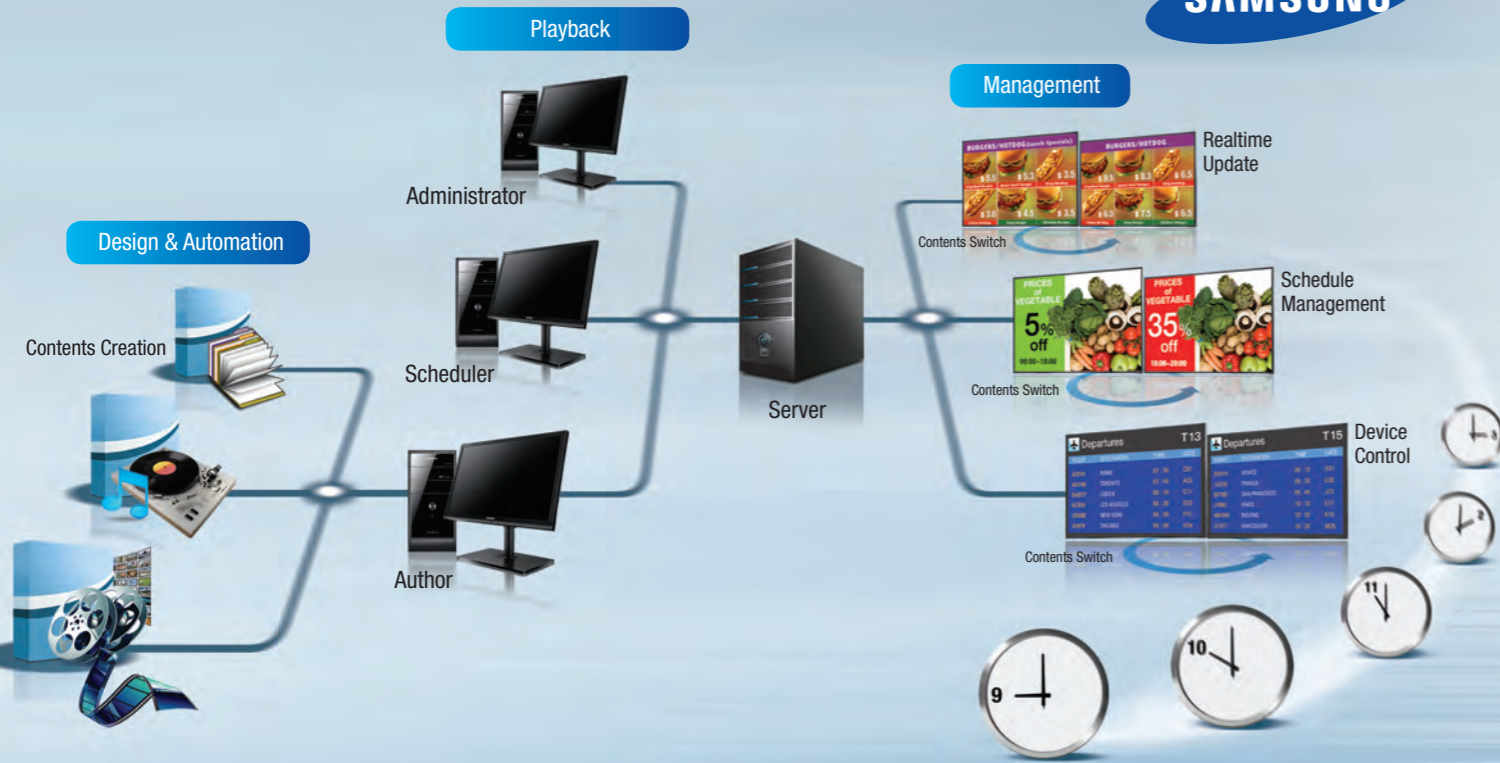

Optimized to deliver greater impact and efficiency

A large format display can be more than just a vehicle for your company's messaging. It can be a professional business solution that connects you to a wide variety of content so your messaging is as impactful as possible. The MagicInfo-i Premium has been optimized for Samsung Large Format Displays (LFD) to provide the superior technology solution to help grow your business in a cost effective manner. Through a global network of distributors and partners, your Samsung LFDs can display the right content, to the right people, at the right time-from anywhere in the world. The Samsung LFD is also equipped with a full suite of powerful software and user-friendly applications that will allow businesses to maximize its full capabilities. The software will enable a streamlined workflow that will establish an improved content management process from a centralized or remote location. Plus, the intuitive interface helps to deliver a comprehensive display solution that is at the top of its class. With a centralized management system, businesses can stay informed on the health of their network with minimal effort to maximize their return on investment.



Why Samsung MagicInfo-i Premium?

The MagicInfo-i Premium software is an optimized solution specifically designed for the Samsung LFD. It provides precise control and secure management of the LFD that's not possible by any other software package. This powerful solution is also cost effective since additional software does not need to be purchase for maximum performance.

Server | Access the right content, at the right time

The MagicInfo-i Premium Server is a powerful web-based tool that's used to manage and deploy content from anywhere in the world. It provides our customers with an efficient, streamlined way to display information on a large scale. The servers can be accessed through a web browser to remotely control devices and administer users. With multi-user capabilities, the MagicInfo-i Premium Server is extremely flexible and scalable so that it can accommodate a wide range of users and address an even wider range of uses. A user-friendly interface provides an easy way for customers to set-up scheduling through Windows Internet Explorer. Plus, enhanced compatibility between the Author/Client enables the server to provide easier and more precise control and management.

- Control compatible devices with the client program (e.g., web-based remote control including source selection, volume adjustment, and more), remote device monitoring, and display control
- Convenient content management through the Auto Scheduling feature, which includes content version management, media content, and content schedule management
- Quick access to the LFD controls on the server through a convenient smart phone app

Author | Craft the message that your audience craves

Create a customized message with the MagicInfo-i Premium Author. This bundled program provides users with a simple way to create content without having to purchase a separate program. It can help develop effective displays and interactive content by assembling a wide range of design elements, such as Shape, FLASH, Image, Input Source, Sound, and Video, all through a single, integrated server. MagicInfo-i Premium Author provides a blank canvas that can be tailored to display the most relevant and effective content for your audience. What's more, the MagicInfo-i Premium Author has an easy-to-use interface and provides a streamlined way to search for and publish the appropriate content.

- Convenient environment for layout and screen divide editing
- Excellent server compatibility allows for easy uploading and downloading of content, as well as updating
- Create simple Flash animation through an easy-to-use script wizard for touch screen products
- Simple content design through easy-to-use templates, timelines, and layers

Client | Bring your vision to life

The MagicInfo-i Premium Client provides an efficient way to display the content created with the MagicInfo-i Premium Author tool or other multimedia content housed in other servers of local area networks. This optimized application provides users with a number of unique user-friendly features like playback with various effects, different display modes, and other functions that will enhance the display of the content. Users can also control the publishing schedule of the content so files and other interactive content by accessing the centralized server or local USB Memory.



About Smart Presentations Limited

WHAT WE DO

Smart Presentations Limited is an innovative technology systems integrator. We help organisations expand the potential of what groups of people working together can achieve.

Our interactive technology solutions deliver tools and working processes that drive business productivity and bring greater success.

Our mission is to be the preferred choice for organisations by virtue of our reputation and the quality of our services: 'Right First Time'.

Our reputation for delivering what we say we will on the day of completion is the foundation of our long-term success. This positive experience has made us our clients' preferred choice – and brings us lots of referred business.

'Right First Time' means all client projects are delivered:

- Fully operational
- On time
- Snag free
- All project documentation on completion

OUR APPROACH

Our consultative approach allows every client to benefit from a comprehensive 'one-stop-shop' service for AV systems integration:

- Consultancy
- Project Management
- Installation
- Training
- Maintenance
- Asset Value Plan (lease finance)
- Rental

SAY HELLO....

Let us help you drive productivity with innovative technology for your business that will make your presentations and meetings go further.

01296 642000

info@presentations.co.uk

www.presentations.co.uk

Smart Presentations Limited

Unit 29, Space Business Centre, Smeaton Close, AYLESBURY, Buckinghamshire, HP19 8FJ

T: 01296 642000 **E:** info@presentations.co.uk **www.presentations.co.uk**

Company Registered No. 07747730 VAT No. 120 3265 66

