

Roller Blind Systems



Application Chart

Operation	Dimensions					Applications		Profile		Features / Options						Fitting Options			Fitting Surfaces			System
	min.	max.	max.	m ² max.	kg max.	Heavy Duty	Sloping	Profile Number	Profile Diameter (ø mm)	Connected Systems (one Drive)	Side-by-Side Systems (two Drives)	Side Guides available	Fascia Cover available	Stop Controller available	Child Safety Device	Ceiling Fitting	Wall Fitting	Recess Fix	Wood	Concrete	Suspended Ceiling	
	42 cm	2.4 m	3 m	7.2 m ²	2.2 kg	●		10531	ø41	●	●		●		●	●	●	●	●	●	●	4900
	50 cm	1.8 m	2.8 m	5 m ²	2.5 kg	●		4227	ø32						●	●	●	●	●	●		4907
	60 cm	2.4 m	3 m	7.2 m ²	3 kg	●		10531	ø41	●	●		●	●	●	●	●	●	●	●	●	4910
	120 cm	3.3 m	4 m	10 m ²	7 kg	●	●	4701	ø55	●		●	●	●	●	●	●	●	●	●	●	4830
	50 cm	4 m	6 m	15 m ²	12.5 kg	●	●	4901	ø80				●	●	●	●	●	●	●	●	●	4840
	50 cm	5 m	3.75 m	15 m ²	9.5 kg			4957	ø110						●	●	●	●	●	●	●	
	61 cm	2.4 m	4 m	9.6 m ²	5.5 kg	●		10532	ø41	●	●	●			●	●	●	●	●	●	●	4960
	70 cm	3.3 m	5 m	14 m ²	10 kg	●	●	4701	ø55	●		●	●		●	●	●	●	●	●	●	4870
	72 cm	4 m	12 m	36 m ²	23 kg	●	●	4901	ø80				●		●	●	●	●	●	●	●	4880
	72 cm	5 m	9 m	36 m ²	23 kg			4957	ø110						●	●	●	●	●	●	●	

Fascia Application

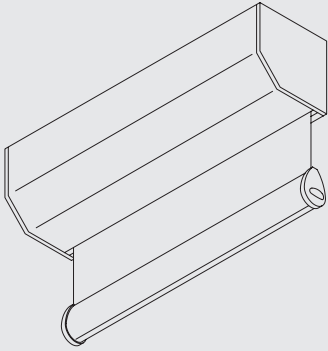

Fascia cover 4702; applicable for systems 4830/4870

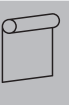

www.silentgliss.co.uk

www.silentglissglobal.com

Silent Gliss Ltd
Pyramid Business Park
Poorhole Lane
Broadstairs
Kent
CT10 2PT
Great Britain

Tel: +44 (0) 1843 863571
Fax: +44 (0) 1843 864503
info@silentgliss.co.uk

Silent Gliss Global Ltd
Pyramid Business Park
Poorhole Lane
Broadstairs
Kent
CT10 2PT
Great Britain

Tel: +44 (0) 1843 874250
Fax: +44 (0) 1843 874457
info@silentglissglobal.com