

# DRIVE

## Electromechanical multi-point lock GENIUS 2.2

AS 2xxx EA / EB / CA / CB

Window systems

Door systems

Comfort systems



**Table of contents**

<b>1</b>	<b>ABOUT THIS DOCUMENTATION</b> .....	<b>4</b>	3.8.2	Analogue connection .....	29
1.1	Read the instructions .....	4	3.8.3	Analogue connection for smoke protection and fire-rated doors .....	31
1.2	Producer .....	4	3.9	Technical specifications .....	32
1.3	Notice on gender .....	4	3.10	Accessories .....	32
1.4	Target group .....	4	<b>4</b>	<b>ASSEMBLY</b> .....	<b>33</b>
1.5	Applicable information .....	4	4.1	Preparation for installation .....	33
1.6	Symbols used .....	5	4.2	Tooling and work equipment .....	34
1.6.1	Element materials .....	5	4.3	Assembly of sash components .....	35
1.6.2	Tooling and work equipment .....	5	4.3.1	Change DIN orientation of the main lock latch .....	35
1.6.3	LED .....	5	4.3.2	Screwing the multi-point lock into place ..	36
1.6.4	Other symbols .....	5	4.3.3	Assembly of handle set and cylinder lock ..	38
1.7	Abbreviations .....	6	4.4	Assembling the frame parts .....	38
<b>2</b>	<b>SECURITY</b> .....	<b>7</b>	4.4.1	Screw on striker plates .....	38
2.1	Intended use .....	7	4.4.2	Screw on locking rail .....	40
2.2	Requirements for the target groups .....	7	<b>5</b>	<b>COMMISSIONING</b> .....	<b>41</b>
2.3	Safety notes .....	8	5.1	Adjusting the residual airgap .....	41
<b>3</b>	<b>PRODUCT SPECIFICATIONS</b> .....	<b>9</b>	5.2	Adjustment of the frame parts .....	41
3.1	Scope of delivery .....	9	5.2.1	Reduce the pressure on the door seal ....	42
3.1.1	AS 2xxx .....	9	5.2.2	Increase the pressure on the door seal ...	44
3.1.2	Required components .....	10	5.3	Functional test .....	46
3.2	Structure .....	11	5.3.1	Check the latch function .....	46
3.3	Operating and display elements .....	11	5.3.2	Check the door function .....	47
3.3.1	LED button .....	11	5.3.3	Check the cylinder operated lock .....	47
3.3.2	Status LED .....	12	5.3.4	Checking the locking elements .....	48
3.4	Operation .....	12	5.3.5	Check automatic locking part .....	49
3.4.1	Functions of the electromechanical drive .	12	5.3.6	Check manual locking part .....	50
3.4.2	Automatic door lock .....	12	5.4	Adjustment of menu functions .....	50
3.4.3	Changeover day / night operation .....	13	5.4.1	Adjustment of volume .....	50
3.4.4	Status feedback .....	14	5.4.2	Adjustment of day / night mode changeover .	51
3.4.5	Comfort function .....	14	5.4.3	Adjustment of the status feedback function (for versions EB and CB) .....	53
3.5	Menu .....	15	5.4.4	Adjustment of the relay function (for versions EB and CB) .....	54
3.6	Dimensions .....	17	5.4.5	Change the cylinder operated lock of the main lock .....	55
3.6.1	Size variants AS 2xxx .....	17	5.4.6	Couple SI-BUS devices .....	56
3.6.2	Dimensions of main lock .....	19	5.4.7	Establishing the WIFI connection .....	57
3.6.3	Dimensions of auxiliary box .....	23	5.5	Install the SIEGENIA Comfort app .....	58
3.6.4	Dimensions GENIUS drive .....	23	<b>6</b>	<b>TROUBLESHOOTING</b> .....	<b>59</b>
3.7	Processing dimensions .....	24	6.1	Replacement of drive .....	60
3.7.1	Milling dimensions for main locks .....	24	6.2	Teach in magnetic sensor .....	63
3.7.2	Milling dimensions for auxiliary box .....	24	6.3	Start reference run .....	64
3.7.3	Milling dimensions for drive .....	25	<b>7</b>	<b>CERTIFICATES</b> .....	<b>65</b>
3.7.4	Drilling dimensions for lever handle .....	25	7.1	EU Declaration of incorporation .....	65
3.7.5	Milling dimensions for profile cylinder ...	26			
3.7.6	Milling dimensions for main striker plate ..	26			
3.7.7	Milling dimensions for additional striker plate .....	27			
3.7.8	Milling dimensions for magnets .....	27			
3.8	Electrical connection for AS 2xxx .....	28			
3.8.1	Digital connection via SI-Bus .....	28			

## 1 About this documentation

### 1.1 Read the instructions

These instructions are an important document and part of the product. Only the defined procedures are safe. Persons can be injured or material damage could occur if these instructions are not observed.

Read and observe the instructions completely prior to the installation of the product.

### 1.2 Producer

KFV Karl Fliether GmbH & Co. KG  
Siemensstraße 10  
42551 Velbert  
Germany

You can find the addresses of our worldwide locations here:  
<https://www.siegenia.com/en/company/locations>

### 1.3 Notice on gender

The linguistic form used serves for easier readability and always means all genders as long as nothing else is explicitly mentioned.

### 1.4 Target group

This information is intended for producers of construction elements, fitters and retrofitters.

Producers of construction elements comprise all persons who carry out the following activities:

- Fabricate KFV products in door elements

The target group "fitters and retrofitters" comprises all persons who carry out the following activities:

- KFV install and repair products in a building project
- install and repair door element that are equipped with KFV products in a building project
- retrofit door elements with KFV products

### 1.5 Applicable information

Note the following applicable information prior to installation.

- Operating instructions electromechanical multi-point lock GENIUS 2.2

<http://link.si/td/elek026/0423>



- Assembly and operating instructions SIEGENIA access control system

<http://link.si/td/elek027/0423>



- Assembly and operating instructions IO module/IO module smart

<https://link.si/td/elek010/0322>



- Assembly and operating instructions SI-BUS cable transfer

<https://link.si/td/elek021/0123>



- Assembly instructions KNX Gateway

<http://link.si/td/elek023/0622>



- DIN ISO 2768-1:1991-06 General tolerances
- Assembly instructions of the producer for the door hardware

## 1.6 Symbols used

### 1.6.1 Element materials



PVC



Timber



Metal

### 1.6.2 Tooling and work equipment



Screw head PZD



Screw head Torx



Phillips screwdriver PZD



Allen key Torx

### 1.6.3 LED

- LED off
- LED lights up
- ☀ LED flashes in 1 colour
- ☀ LED flashes alternately in 2 colours

### 1.6.4 Other symbols

- ☀/☾ Changeover day / night operation

## 1.7 Abbreviations

<b>ACS</b>	Access control system
<b>A-opener</b>	Automatic opener
<b>CA</b>	Multi-point lock with comfort function with electronic type A
<b>CB</b>	Multi-point lock with comfort function with electronic type B
<b>D</b>	Backset
<b>E</b>	Distance
<b>EA</b>	Multi-point lock without comfort function with electronic type A
<b>EB</b>	Multi-point lock without comfort function with electronic type B
<b>ETS</b>	Engineering tool software
<b>FFB</b>	Sash rebate width
<b>FFH</b>	Sash rebate height
<b>H</b>	Timber
<b>MFV</b>	Multi-point lock
<b>MV</b>	Size variant
<b>PDB</b>	Profile data sheet
<b>PVC</b>	PVC
<b>PZ</b>	Profile cylinder
<b>PZD</b>	Pozidrive
<b>RC</b>	Resistance class
<b>Replacement part</b>	Stop for the main lock latch
<b>RZ</b>	Round cylinder
<b>SI-Bus</b>	SIEGENIA bus system

## 2 Security

### 2.1 Intended use

- GENIUS 2.2 is a hardware system that locks and unlocks entrance doors via motor function.
- The product is suitable for installation in entrance doors made of timber, metal or PVC.
- The product is suitable for installation in single-sash and double-sash doors in permanent buildings.
- The hardware system is intended for use in vertically installed windows or doors.
- The product is not suitable for use in escape and rescue routes in accordance with EN 179 or EN 1125.
- Modifications of the product for use in fire-rated doors, which are not defined in these instructions, are inadmissible.
- Only use the product in conjunction with the approved fire protection cable in fire-rated doors.
- Only use the product in conjunction with the approved emergency power buffer in fire-rated doors.
- An electrical or mechanical snib latch is inadmissible in fire-rated doors.
- The product for automatic door release with the SIEGENIA access control system is inadmissible in fire-rated doors.
- Only use accessories that are tested and certified in accordance with the EMC directive. Any change of this combination (even a partial change) or any change of the product is inadmissible.
- Only use cylinder locks with free-running cam FZG in accordance with DIN 18252.
- If the product is installed in combination with a motorised door drive, the motorised door drive must be tested according to EN 16005.
- Do not route SI-BUS cables and analogue cables on cable racks, in roof cavities or in shared cable ducts in public buildings or high-rise buildings.

### 2.2 Requirements for the target groups

We assume and require that manufacturers of building elements possess the following knowledge and skills:

- knowledge of the regulations concerning occupational safety and accident prevention
- comprehension of technical correlations according to state-of-the-art science and technology
- knowledge of professional work steps
- knowledge of the applicable standards and directives
- knowledge of applicable testing regulations
- knowledge and skills with regard to material processing of the respective material (timber, PVC, metal)
- knowledge and skills with regard to the professional use of tooling, machines and systems for the production of door elements
- knowledge and skills with regard to the professional fixing of technical elements
- knowledge in functional testing and operation of door elements
- knowledge of the requirements of profile system providers
- knowledge and skills with regard to the professional fabrication of electrical components
- knowledge and skills with regard to the work steps:
  - connecting electrical components
  - commissioning electrical components
  - checking the function of electrical components
- knowledge of the 5 safety rules:
  - enable
  - secure against reactivation
  - ensure that system is voltage-free
  - earthing and short-circuiting
  - cover or isolate proximate live parts

KFV offers training courses for the acquisition of some of the required knowledge and skills. Contact your KFV sales consultant in case of requirement.

We assume and require that fitters and retrofitters possess the following knowledge and skills:

- knowledge of the regulations concerning occupational safety and accident prevention
- comprehension of technical correlations according to state-of-the-art science and technology
- knowledge of professional work steps
- knowledge of the applicable standards and directives

If the door elements are equipped with an electromechanical drive or a sensor, the following knowledge and skills are presumed and required:

## DRIVE – Assembly instructions

Electromechanical multi-point lock GENIUS 2.2, AS 2xxx EA / EB / CA / CB

---

- knowledge and skills with regard to the professional use of electrical and mechanical tooling
- knowledge and skills with regard to the professional fixing of technical elements
- knowledge and skills with regard to the retrofit of mechanical security technology on door elements
- knowledge and skills with regard to the professional fabrication of electrical components
- knowledge and skills with regard to the work steps:
  - connecting electrical components
  - commissioning electrical components
  - checking the function of electrical components
- knowledge of the 5 safety rules:
  - enable
  - secure against reactivation
  - ensure that system is voltage-free
  - earthing and short-circuiting
  - cover or isolate proximate live parts

If the door elements are equipped with an electromechanical drive or a sensor, the following knowledge and skills are presumed and required:

KFV offers training courses for the acquisition of some of the required knowledge and skills. Contact your KFV sales consultant in case of requirement.

### 2.3 Safety notes

#### Material damage due to inappropriate transport

The multi-point lock can be damaged during transport if the locking elements are in the locking position.

- Ensure that the locking elements are in the release position.

#### Material damage due to improper assembly

You will damage the multi-point lock if you do not install the handle set properly.

- Once the gear box is installed, do not drill through the door leaf.
- Do not knock the square spindle of the lever handle into the locking groove with force.

#### Material damage due to carrying by the lever handle

You will damage the multi-point lock if you carry the door leaf by the lever handle.

- Use suitable aids to transport the door leaf.

**3 Product specifications**

**3.1 Scope of delivery**

**3.1.1 AS 2xxx**

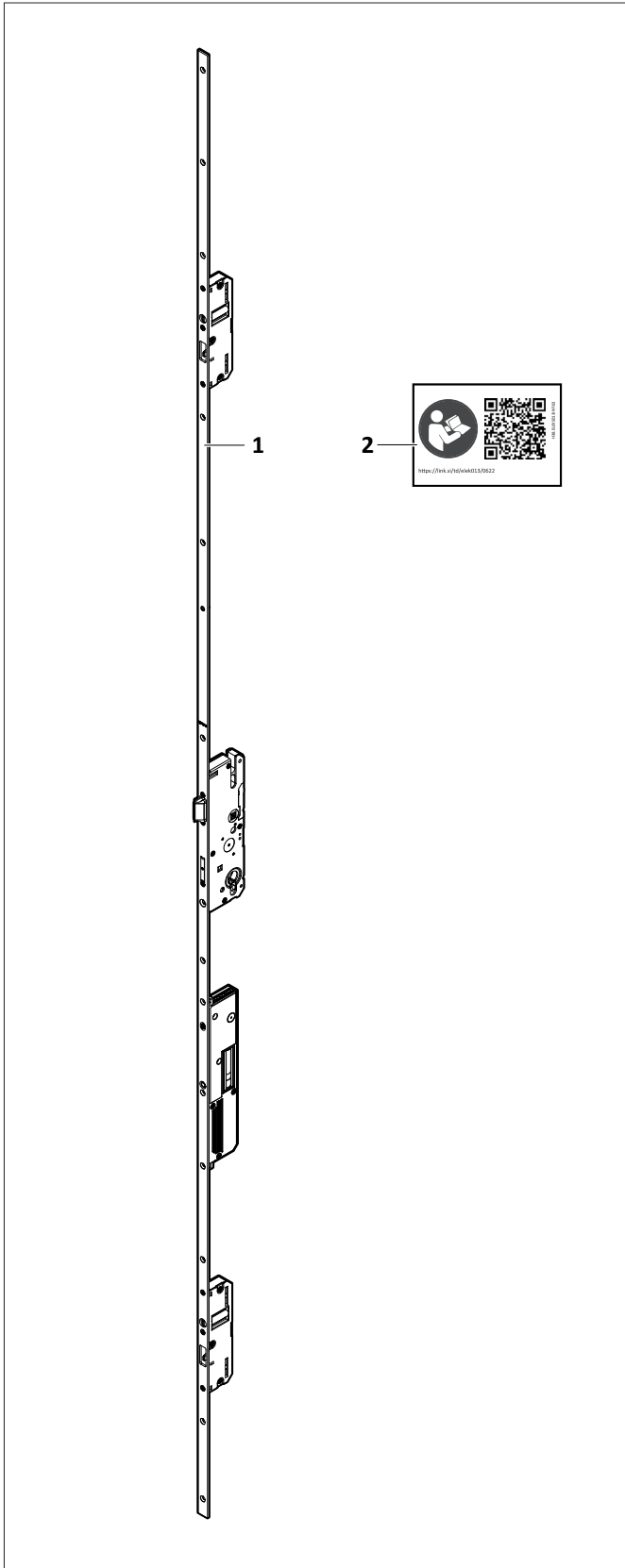

Item	Name	Quantity
1	Electromechanical multi-point lock GENIUS 2.2	1
2	QR Info	1

# DRIVE – Assembly instructions

Electromechanical multi-point lock GENIUS 2.2, AS 2xxx EA / EB / CA / CB

## 3.1.2 Required components

The listed components are required to establish the function.

For an assembly in accordance with SKG certification, only use frame parts with SKG marking verwenden.

Electively, the following variants are appropriate for the frame parts:

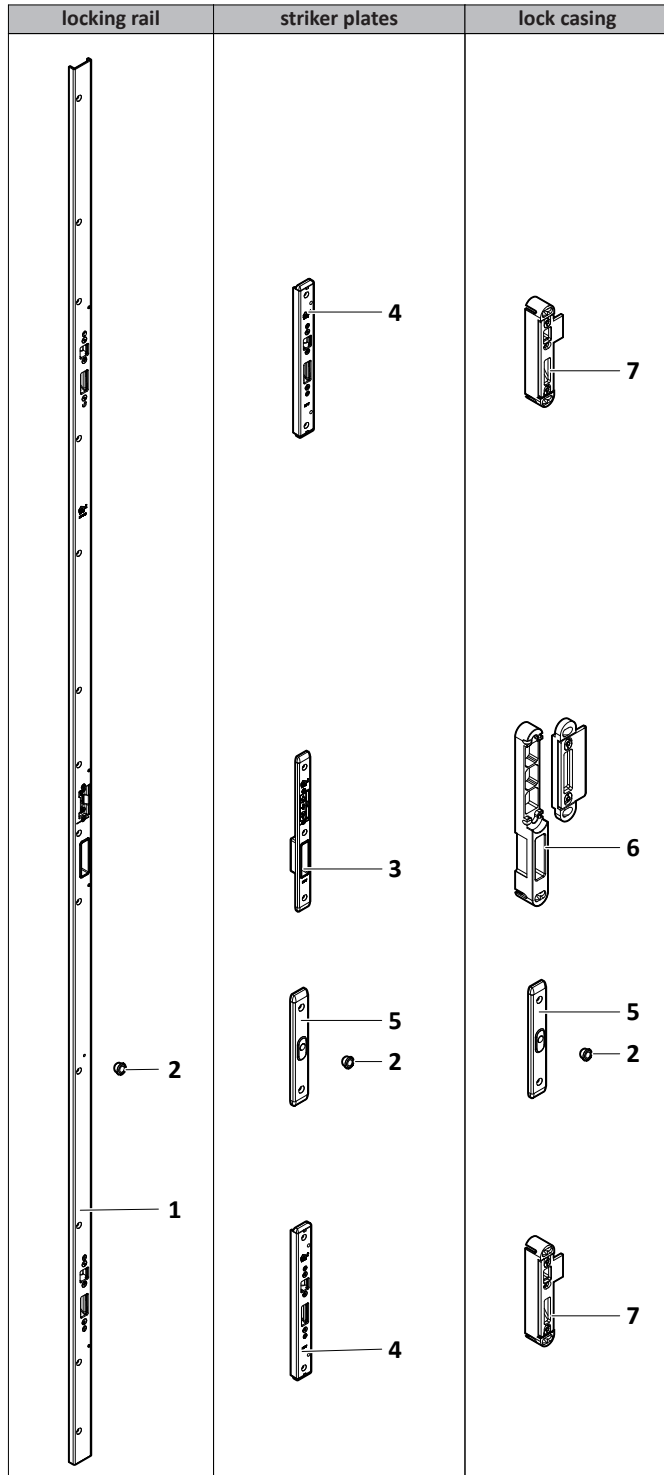

Item	Name	Quantity
1	locking rail	1
2	Magnet	1
3	Main striker plate for latch and deadbolt	2
4	Additional striker plate for round bolt and hook bolt	1
5	Additional striker plate for round bolt with magnet holder (optional for PVC doors and metal doors)	1
6	SKG main lock case for latch and deadbolt in timber frame	1
7	SKG auxiliary lock case for round bolt and hook bolt in timber frame	2

Electively, the following variants are appropriate for the power supply:

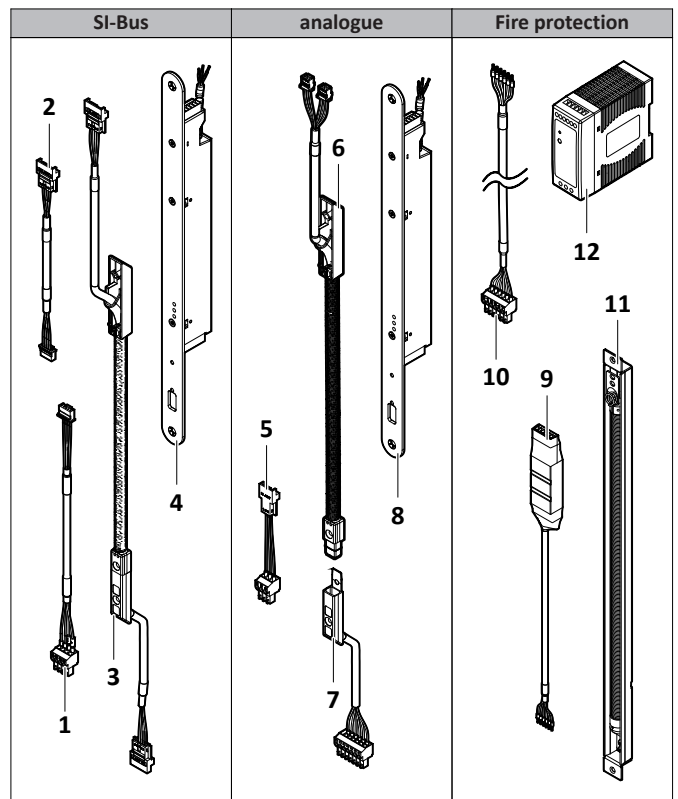

Item	Name	Quantity
1	Adapter cable	1
2	Extension cable	1
3	Cable transfer	1
4	Frame-integrated power supply	1
5	Adapter cable	1
6	Cable transfer, frame side	1
7	Cable transfer, sash side	1
8	Frame-integrated power supply	1
9	Emergency power buffer	1
10	Fire-resistant cable	1
11	Cable transfer	1
12	Top hat rail power supply	1

**3.2 Structure**

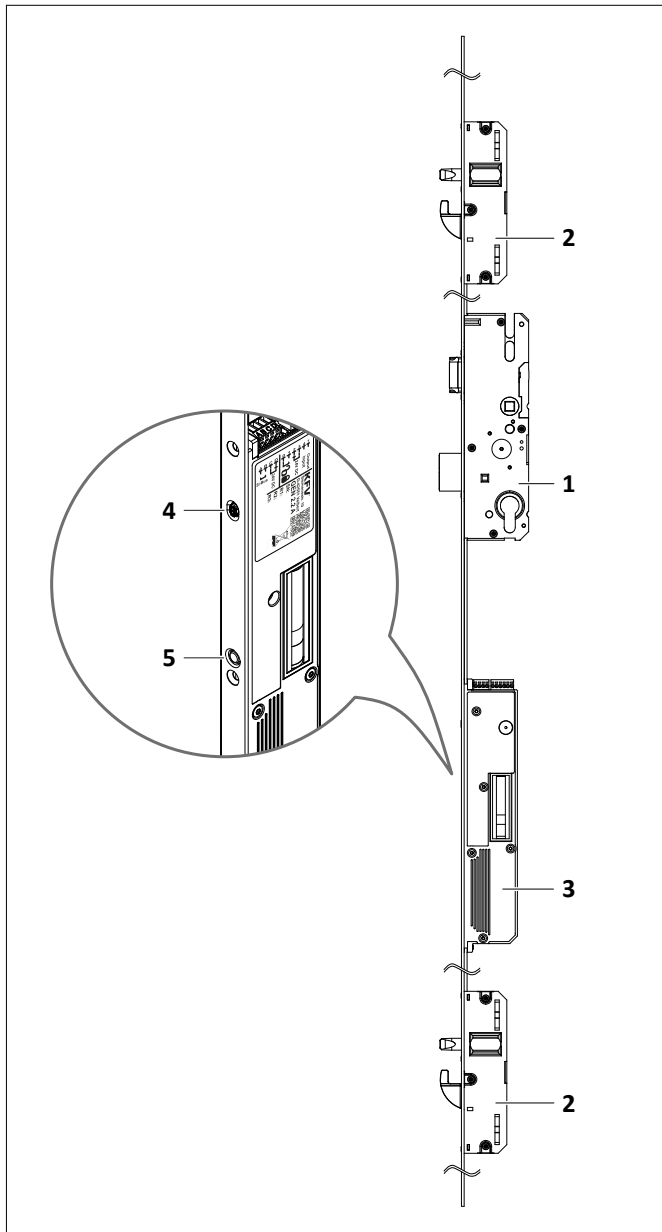

Item	Name
1	Main lock
2	Auxiliary box
3	Electromechanical drive
4	LED button
5	Status LED wit magnetic sensor

**3.3 Operating and display elements**







**3.3.1 LED button**

LED	status
○	The multi-point lock is in day mode.
●	The multi-point lock is in night mode.

## DRIVE – Assembly instructions

Electromechanical multi-point lock GENIUS 2.2, AS 2xxx EA / EB / CA / CB

### 3.3.2 Status LED

LED	status
	The product is now ready for operation.
	The opening signal is present.
	There is a product fault, the product is not ready for operation.
	The contact of the connecting clamp is faulty. The magnetic sensor is not working.
	The locking elements are extended when the door is open.
	There is a general fault. The product is not ready for operation.
	The motor is driven on block.

## 3.4 Operation

### 3.4.1 Functions of the electromechanical drive

	Version			
	EA	EB	CA	CB
<b>Mechanical functions</b>				
Opening via the profile cylinder	●	●	●	●
Comfort function: open via lever handle on the inside of the door	–	–	●	●
<b>Electronic functions</b>				
Opening via an access control system (option)	●	●	●	●
Opening via an E-button (option)	●	●	●	●
SI-BUS interface	●	●	●	●
Switchover between Day and Night mode with an external clock timer	–	●	–	●
Feedback contact for external systems (e.g. motorised door drive or alarm system)	–	●	–	●

Symbol	Explanation
●	Standard version
○	Optional or alternative version
–	not available

### 3.4.2 Automatic door lock

The electromechanical multi-point lock locks the door automatically.

The door unlocks automatically if an access control system or a clock timer is connected. As soon as the

multi-point lock receives an opening signal, the door unlocks for 7 seconds. A signal is emitted during this period. The signal switches off as soon as the door opens. If the door does not open, the multi-point lock locks the door again after the 7 seconds.

**3.4.3 Changeover day / night operation**

The electromechanical multi-point lock offers 2 locking modes:

day mode	The door closes. It does not lock automatically. This means the latch only extends when the door closes. All other locking elements remain retracted. Manual locking is possible via the cylinder lock. Use for highly frequently used door
Night mode	The door closes and locks automatically. This means that all locking elements extend when the door closes. Use for frequently used door, e.g. in apartment buildings or private houses

The switchover between the locking modes is possible via a button is possible for all variants.

An automatic change of operating mode is possible for multi-point locks versions EB and CB. The automatic change can be implemented, for example by clamping a clock timer onto the analogue connection. Both the manual and the automatic change are individually adjustable. The following adjustment options are available:

Function	LED button	Connection to terminal 1	Additional function
1	-	-	-
2	-	●	-
3	●	-	-
4	●	●	-
5	●	●	Single switchover between Day and Night mode is possible
6	●	●	Single switchover from night mode to day mode and back to night mode again is possible

Symbol	Explanation
●	Standard version
○	Optional or alternative version
-	not available

You can find information on function adjustment in chapter Adjustment of day / night mode changeover (see page 51).

### 3.4.4 Status feedback

The electromechanical multi-point locks versions EB and CB enable the feedback of the door status. When a status is reached, the multi-point lock processes this information and emits an output signal. One of the following 6 status inquiries is adjustable via the multi-point lock so that the output signal is emitted:

Function	status
A	The door is closed and locked.
B	<ul style="list-style-type: none"><li>• In day mode: the door is closed</li><li>• In night mode: the door is closed and locked</li></ul>
C	The latch is retracted.
D	<ul style="list-style-type: none"><li>• Active error</li><li>• The latch is retracted</li><li>• The multi-point lock is in the locking process or in the unlocking process</li><li>• The door is closed and locked</li><li>• The door is closed and not locked</li></ul>
E	The door is released.
F	No active error.

You can find information on function adjustment in chapter Adjustment of the status feedback function (for versions EB and CB) (see page 53).

A relay must be clamped onto the analogue connection to process this output signal. The relay links the multi-point lock with third-party systems, e. g. alarm systems. The function of the relay is adjustable as locking bolt or as opener. You can find information on function adjustment in chapter Adjustment of the relay function (for versions EB and CB) (see page 54).

### 3.4.5 Comfort function

The electromechanical multi-point locks versions CA and CB have a comfort function. The comfort function

is a mechanical quick release. The mechanical quick release enables the door to be opened via the lever handle from the inside at any time.

### 3.5 Menu

#### Operating mode switchover

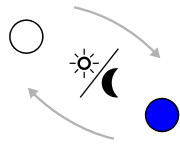

Button pressed on LED button	Description
1 second	Switchover between Day and Night mode

#### Menu level principle

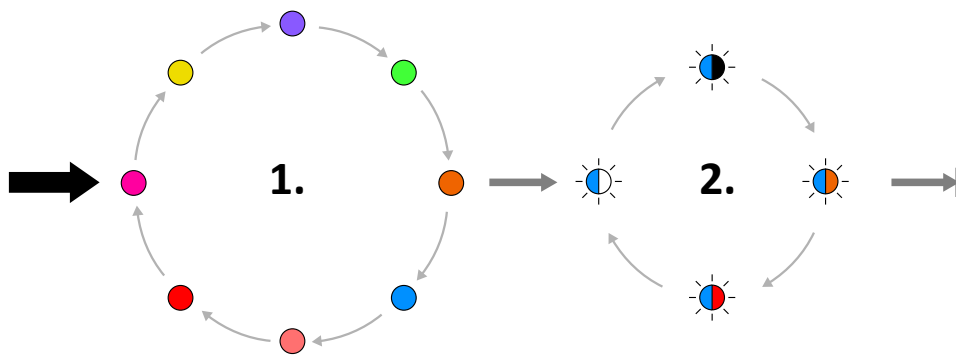

Button pressed on LED button	Description
8 seconds	Change to menu level 1
3 seconds	Change to menu level 2
3 seconds	Save menu items
1 second	Change inside the menu

Mode of operation	Menu levels		
	Level 1	Level 2	value
			100 %
			75 %
			<b>50 % (default setting)</b>
			25 %
			0 %

# DRIVE – Assembly instructions

Electromechanical multi-point lock GENIUS 2.2, AS 2xxx EA / EB / CA / CB

Mode of operation	Menu levels		
	Level 1	Level 2	value
Status feedback function (only for version EB or CB) (see page 14)			
			<b>Function A (default setting)</b>
			Function B
			Function C
			Function D
			Function E
			Function F
<b>Adjustment of the status feedback contact (only for version EB or CB)</b>			
			<b>Locking bolt (default setting)</b>
			N/C contact
Functions of the changeover day / night operation (see page 13)			
			Function 1
			Function 2
			Function 3
			<b>Function 4 (default setting)</b>
			Function 5
			Function 6
<b>Cylinder operated lock of the latch</b>			
			<b>Cylinder operated lock of the latch is active (default setting)</b>
			Cylinder operated lock of the latch is inactive
<b>Device services</b>			
			Restart the device
			Default setting
			Software version
			Teach in magnetic sensor
			Reference run
<b>System services</b>			
			Couple devices
			Separate devices
			Unlock ACS (can only be used with coupled SI-BUS and WIFI-capable device)
			Default settings
			WIFI on (Only useable with coupled SI-BUS and WIFI-capable device)
			WIFI off (Only useable with coupled SI-BUS and WIFI-capable device)
<b>WIFI functions (Only useable with coupled SI-BUS and WIFI-capable device)</b>			
			Reset WIFI
			WPS mode
			Info mode

**3.6 Dimensions**

**3.6.1 Size variants AS 2xxx**

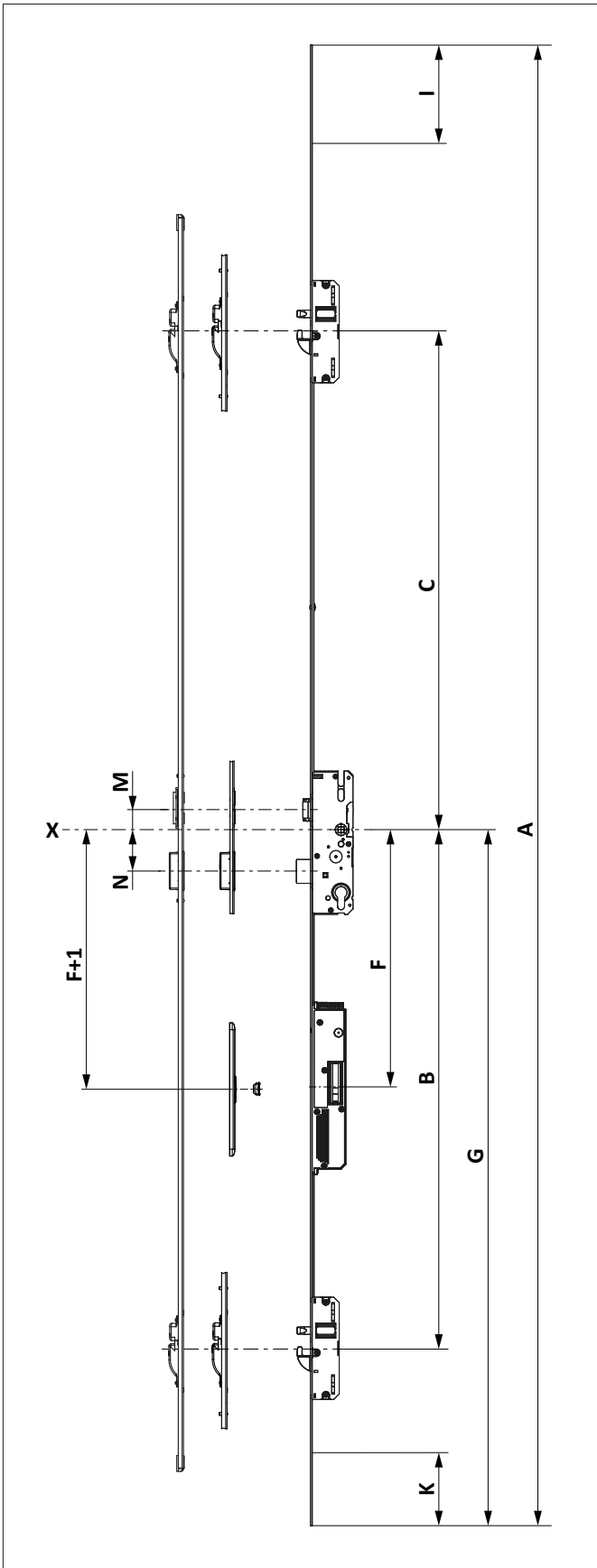

## DRIVE – Assembly instructions

Electromechanical multi-point lock GENIUS 2.2, AS 2xxx EA / EB / CA / CB

X	System marking
A	Total length
B	System marking up to middle of bottom auxiliary box
C	System marking up to middle of top auxiliary box
F	System marking up to middle of drive
F+1	Middle magnet
G	System marking up to upper edge of finished flooring
I and K	Can be shortened
M	Middle of lever handle to middle of latch (see page 19)
N	Middle of lever handle square spindle to middle of deadbolt (see page 19)
Measurements in mm	

E = 72 mm, 92 mm, 94 mm								
Size variant	A (mm)	B (mm)	C (mm)	F (mm)	G (mm)	I (mm)	K (mm)	FFH (mm)
<b>Continuous secondary sash with G = 1020</b>								
<b>B296</b>	2170	760	355	380	1020	665	130	1505 – 1754
<b>B298</b>	2170	760	605	380	1020	415	130	1755 – 1880
<b>B001</b>	2170	760	730	380	1020	290	130	1881 – 2170
<b>B003</b>	2400	760	980	380	1020	270	130	2171 – 2400

<b>Cropped secondary sash with one fastening hole on each sash end</b>									
Size variant	A (mm)	B (mm)	C (mm)	F (mm)	G (mm)	I (mm)	K (mm)	FFH (mm)	
<b>C038</b>	1629	760	605	380	892	355	–	–	1755 – 1880
<b>C002</b>	1754	760	730	380	892	355	–	–	1881 – 2170
<b>C054</b>	2004	760	980	380	892	355	–	–	2171 – 2400

<b>Cropped secondary sash with 2 screw holes on each sash end</b>								
Size variant	A (mm)	B (mm)	C (mm)	F (mm)	G (mm)	I (mm)	K (mm)	FFH (mm)
<b>B039</b>	1500	760	355	380	952	–	–	1505 – 1754
<b>B041</b>	1700	760	605	380	952	–	–	1755 – 1880
<b>B166</b>	1855	760	730	380	952	–	–	1881 – 2170
<b>B253</b>	2170	760	980	380	952	–	–	2171 – 2400
<b>Continuous secondary sash with G = 1050</b>								
<b>B002</b>	2170	760	730	380	1050	260	160	1911 – 2170

E = 85 mm								
Size variant	A (mm)	B (mm)	C (mm)	F (mm)	G (mm)	I (mm)	K (mm)	FFH (mm)
<b>Continuous secondary sash with G = 1050</b>								
<b>C010</b>	2400	727	721	374	1050	500	190	1900 – 2400

E = 88 mm								
Size variant	A (mm)	B (mm)	C (mm)	F (mm)	G (mm)	I (mm)	K (mm)	FFH (mm)
<b>Continuous secondary sash with G = 1016</b>								
<b>B001</b>	2170	756	734	377	1016	290	130	1881 – 2170

3.6.2 Dimensions of main lock

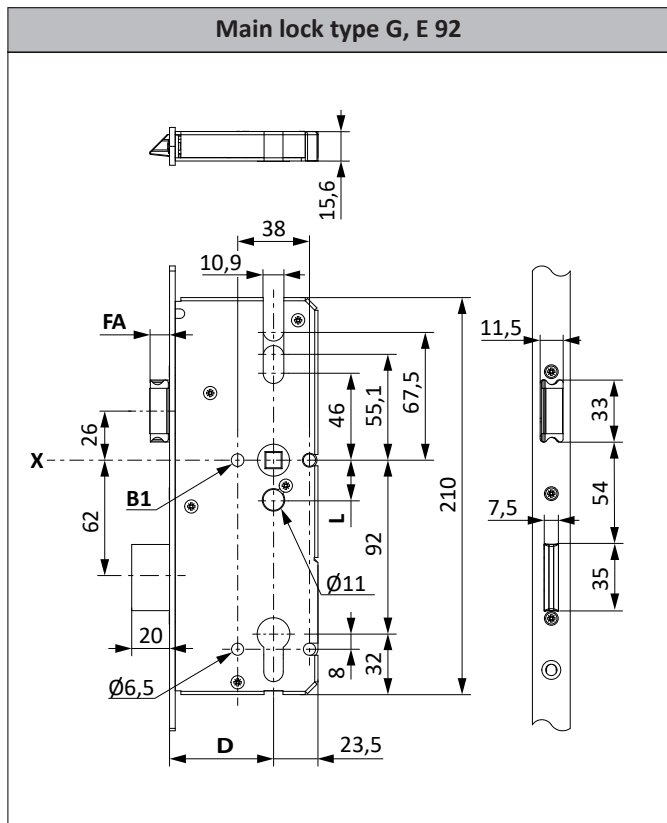
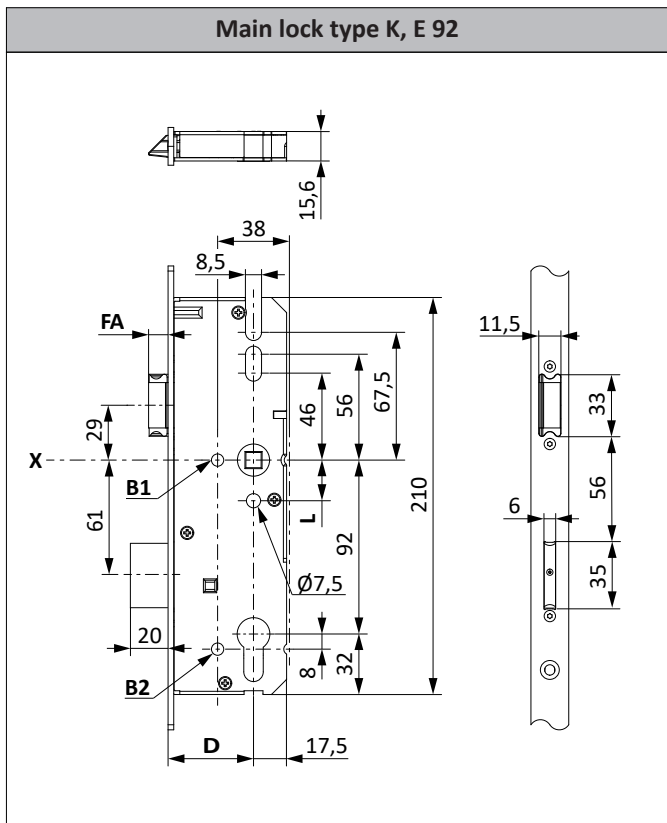

X	System marking
D	Backset
FA	Latch projection
L	Centre from square spindle to through hole
B1	Through hole 1
B2	Through hole 2
Measurements in mm	

X	System marking
D	Backset
FA	Latch projection
L	Centre from square spindle to through hole
B1	Through hole
Measurements in mm	

D (mm)	FA (mm)		L1 (mm)		B1 (mm)		B2 (mm)
	Standard	Fire protection	EA or EB	CA or CB	EA or EB	CA or CB	
35	10	12	21.5	21	Ø6.5	-	-
40							-
45							Ø6.5
50							Ø6.5
55							Ø6.5

D (mm)	FA (mm)		L1 (mm)		B1 (mm)	
	Standard	Fire protection	EA or EB	CA or CB	EA or EB	CA or CB
55	10	12	21.5	21	Ø6.5	-
65						
80						

# DRIVE – Assembly instructions

Electromechanical multi-point lock GENIUS 2.2, AS 2xxx EA / EB / CA / CB

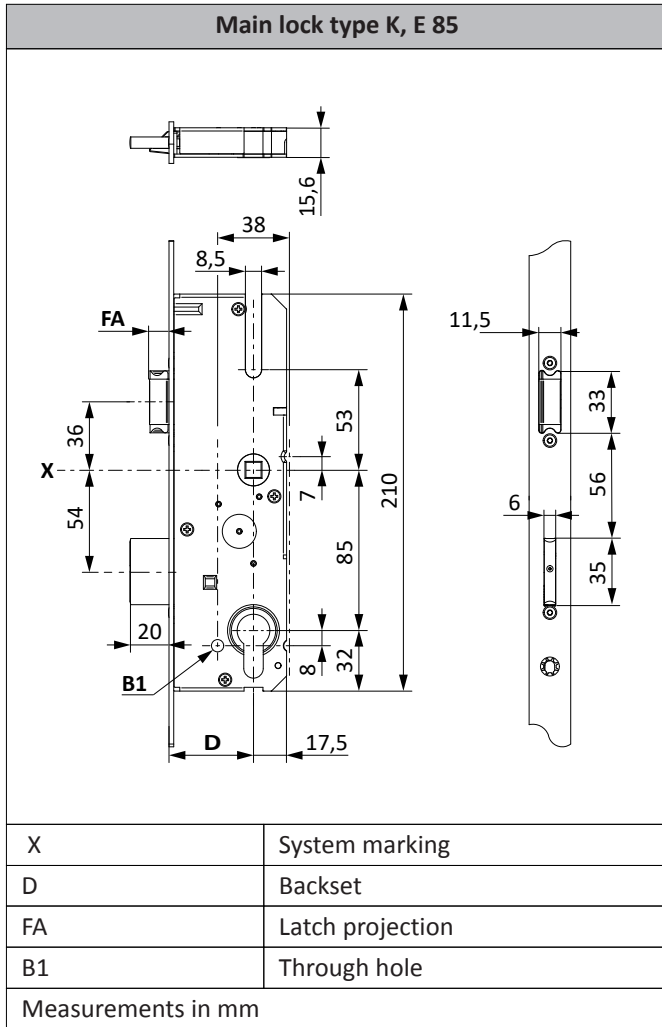

D (mm)	FA (mm)		B1 (mm)
	Standard	Fire protection	
35	10	12	-
40			-
45			Ø6.5
50			Ø6.5

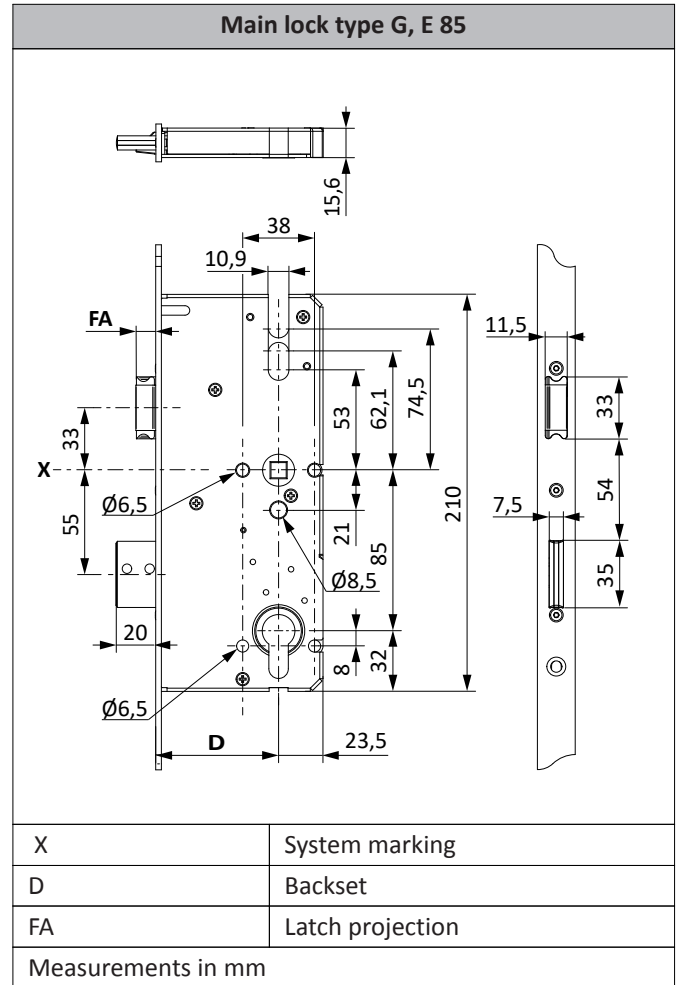

D (mm)	FA (mm)	
	Standard	Fire protection
55	10	12
65		

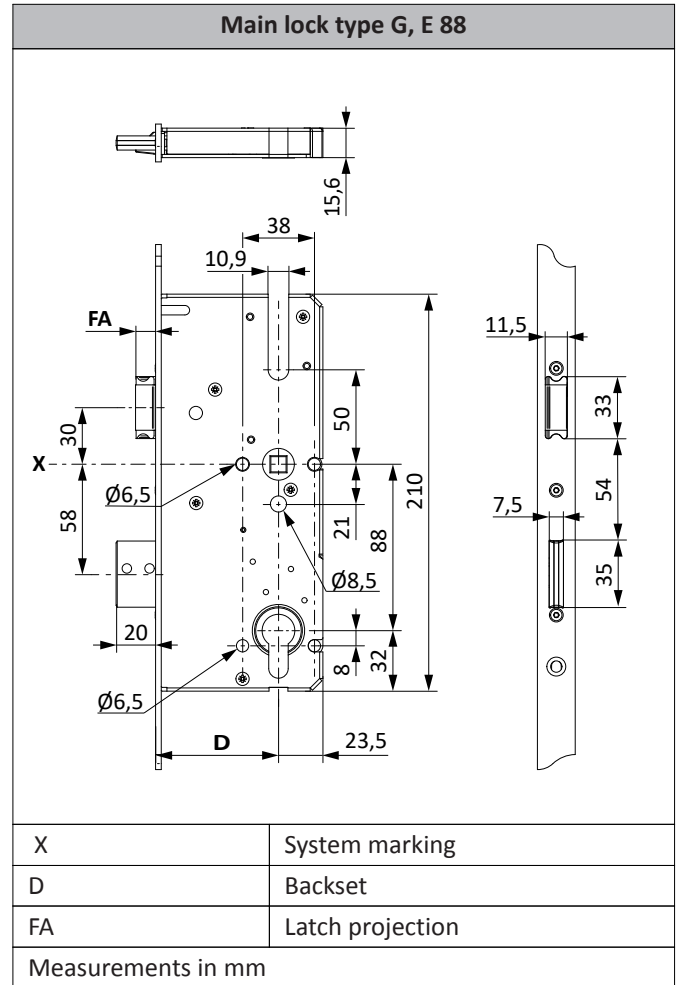
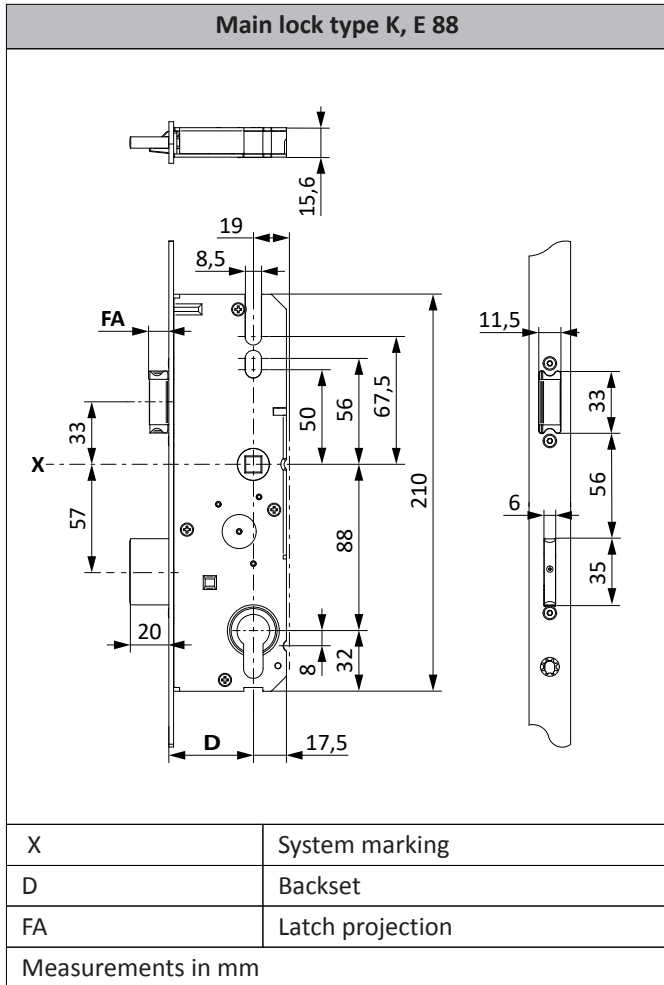

D (mm)	FA (mm)	
	Standard	Fire protection
35	10	12
40		
45		
50		
55		

D (mm)	FA (mm)	
	Standard	Fire protection
55	10	12
65		

# DRIVE – Assembly instructions

Electromechanical multi-point lock GENIUS 2.2, AS 2xxx EA / EB / CA / CB

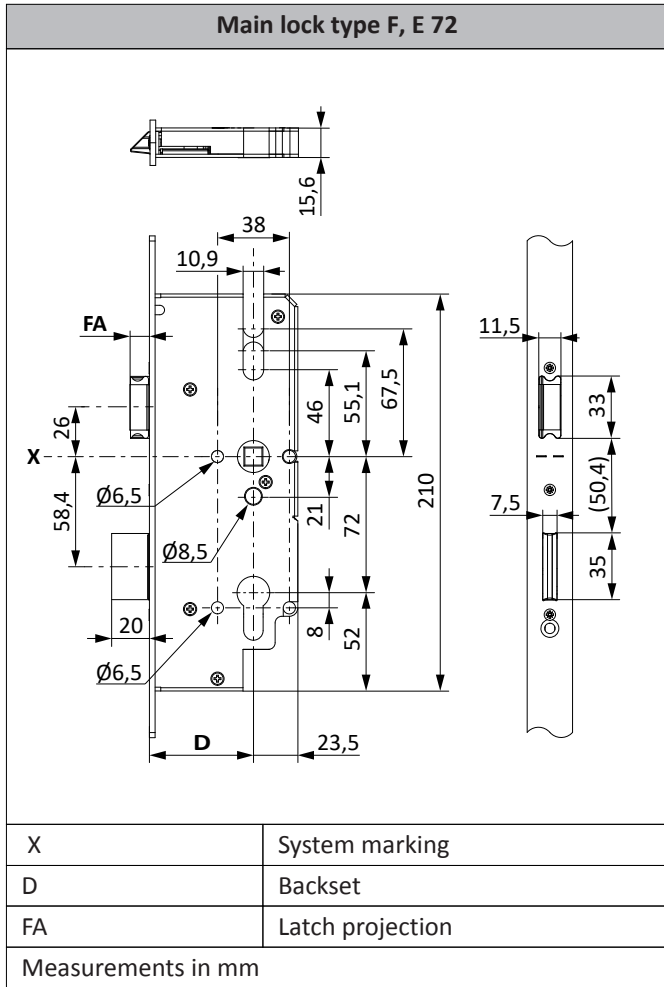

D (mm)	FA (mm)	
	Standard	Fire protection
55	10	12
65		
80		

**3.6.3 Dimensions of auxiliary box**

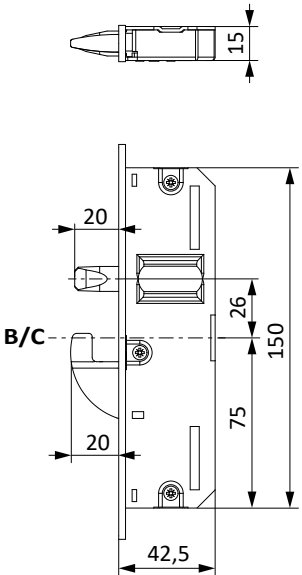
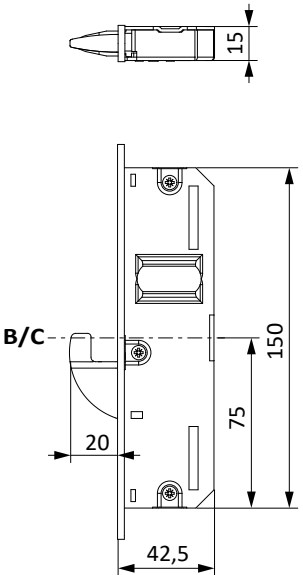
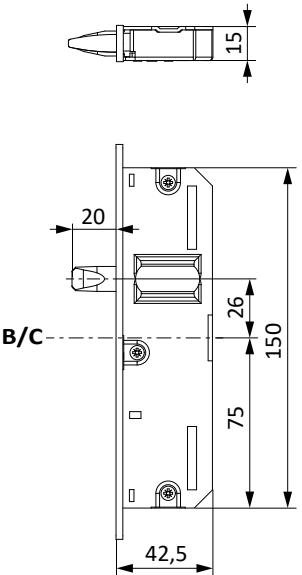
GEN AS 26xx	GEN AS 25xx	GEN AS 23xx
		
B/C		Centre auxiliary box
Measurements in mm		

**3.6.4 Dimensions GENIUS drive**

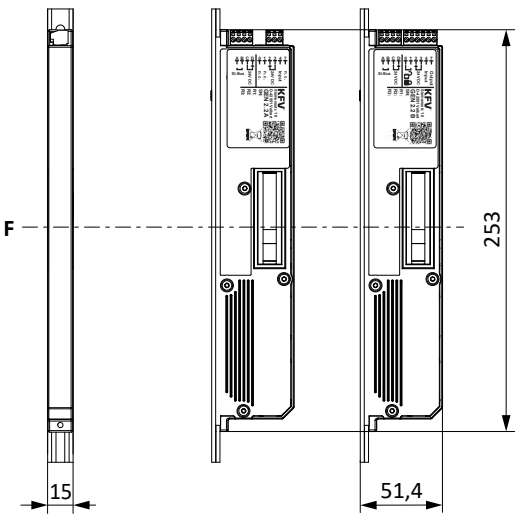
	Centre case GENIUS drive
Measurements in mm	

# DRIVE – Assembly instructions

Electromechanical multi-point lock GENIUS 2.2, AS 2xxx EA / EB / CA / CB

## 3.7 Processing dimensions

### 3.7.1 Milling dimensions for main locks

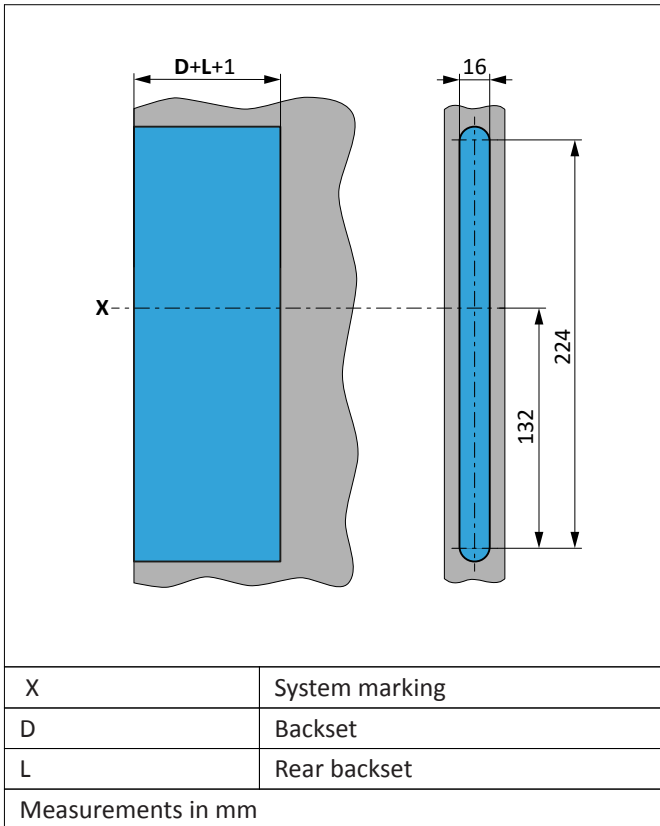

### 3.7.2 Milling dimensions for auxiliary box

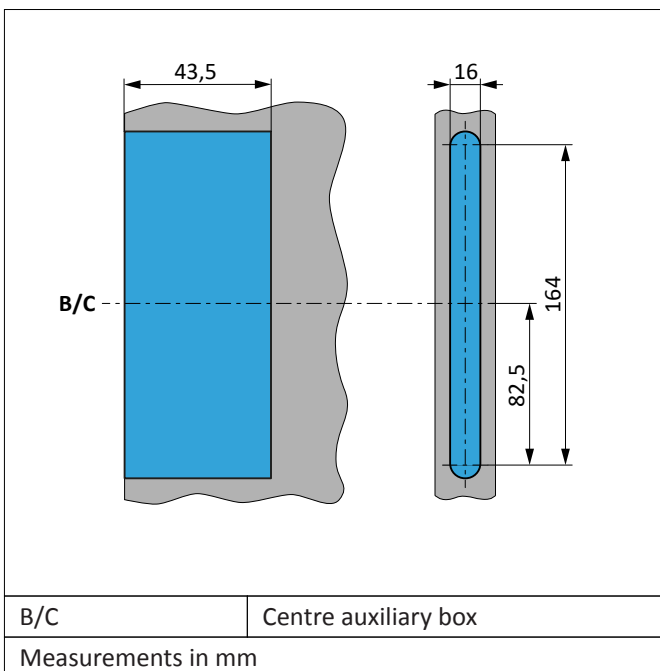

**3.7.3 Milling dimensions for drive**

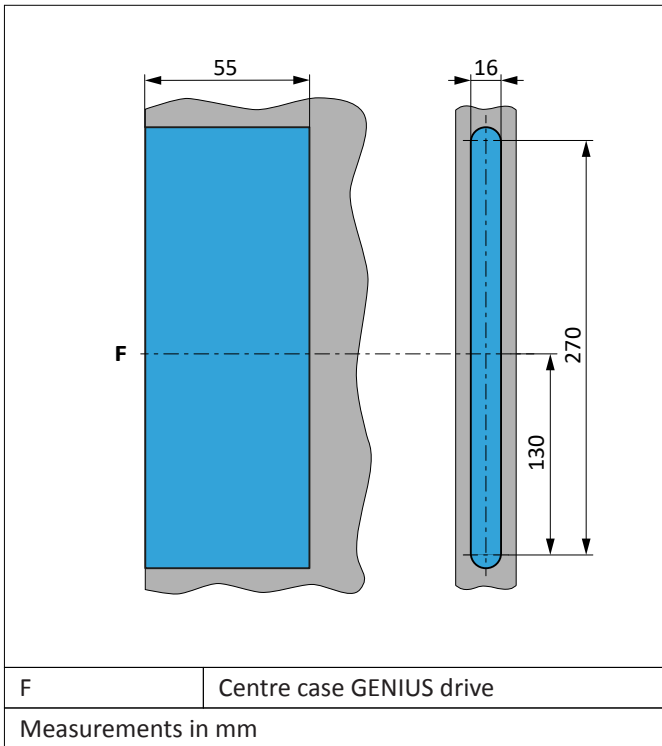

**3.7.4 Drilling dimensions for lever handle**

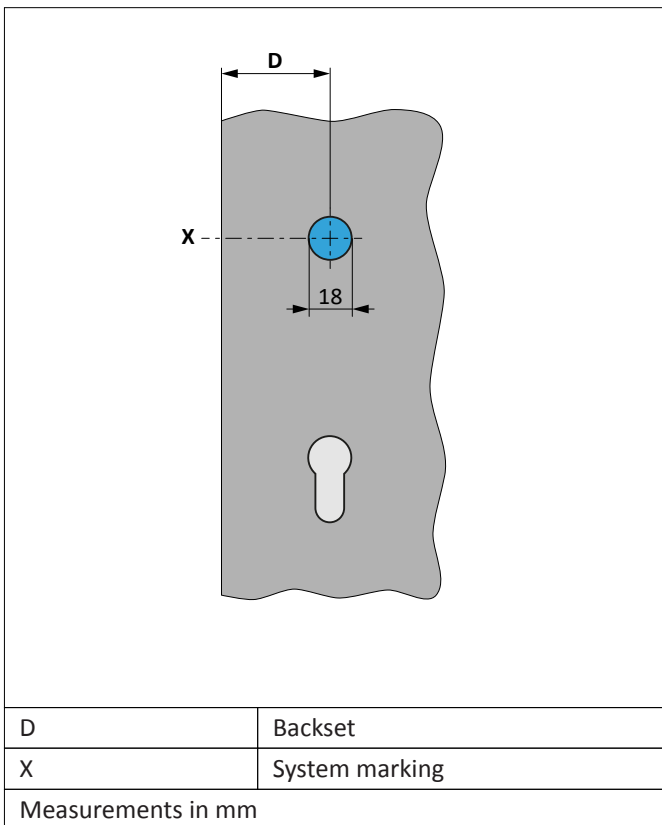

# DRIVE – Assembly instructions

Electromechanical multi-point lock GENIUS 2.2, AS 2xxx EA / EB / CA / CB

## 3.7.5 Milling dimensions for profile cylinder

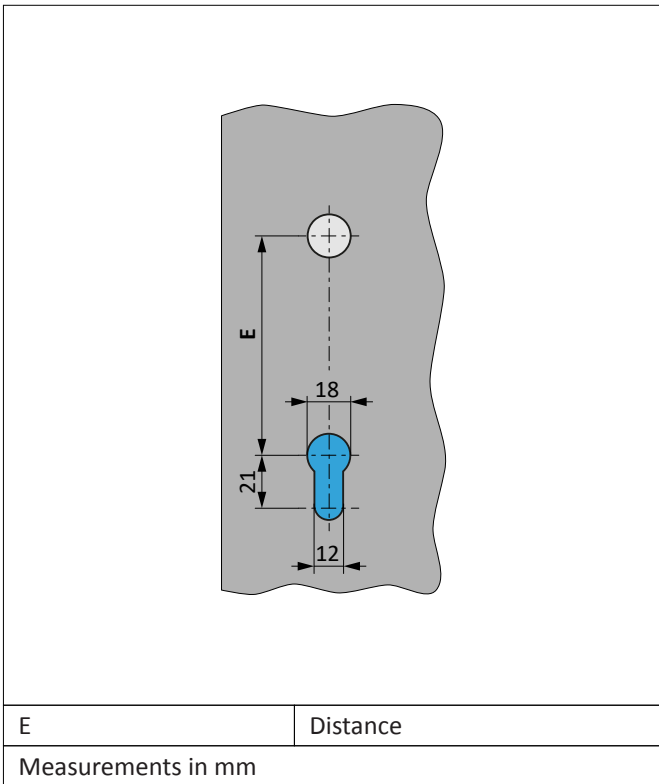

## 3.7.6 Milling dimensions for main striker plate

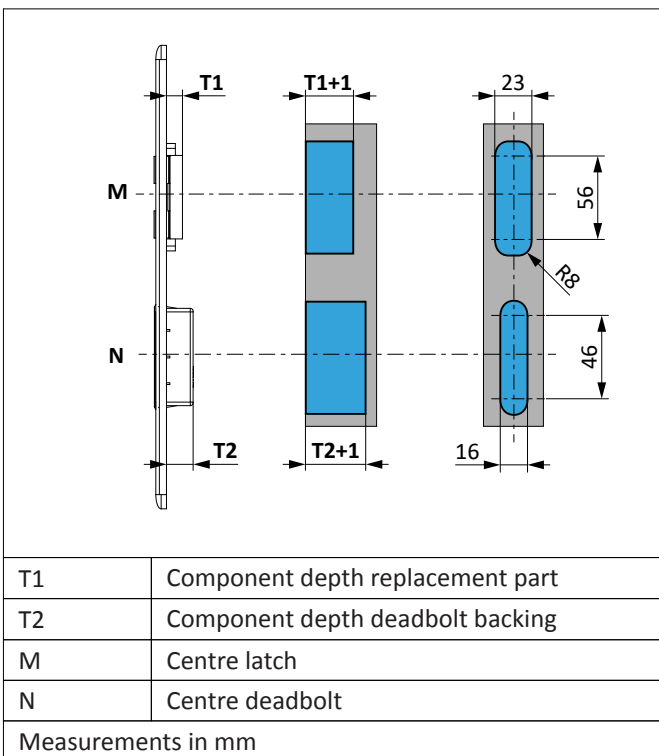

**3.7.7 Milling dimensions for additional striker plate**

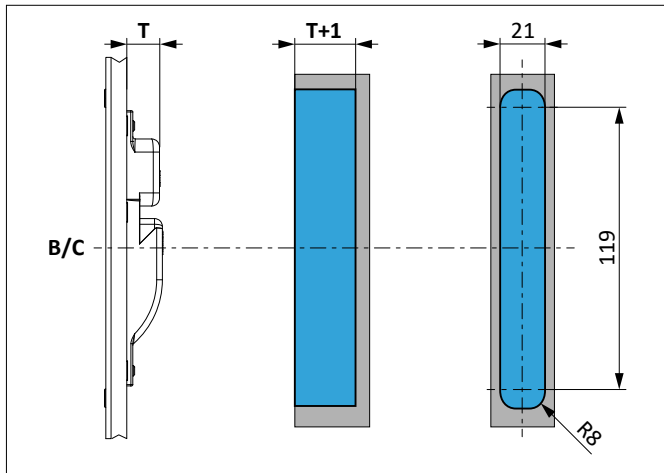

T	Component depth
B/C	Centre auxiliary box
Measurements in mm	

**3.7.8 Milling dimensions for magnets**

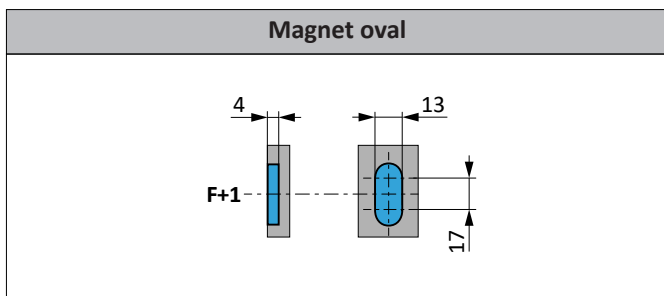

F	Centre drive
F+1	Middle magnetic sensor
Measurements in mm	

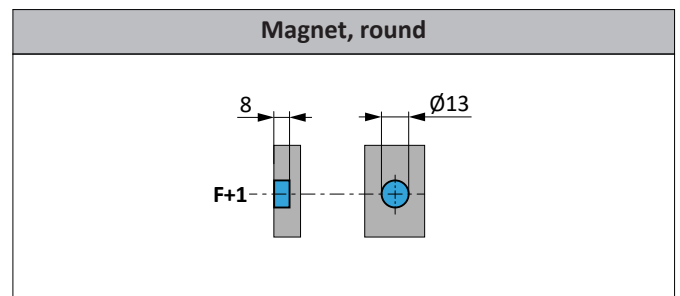

F	Centre drive
F+1	Middle magnetic sensor
Measurements in mm	

# DRIVE – Assembly instructions

Electromechanical multi-point lock GENIUS 2.2, AS 2xxx EA / EB / CA / CB

## 3.8 Electrical connection for AS 2xxx

### 3.8.1 Digital connection via SI-Bus

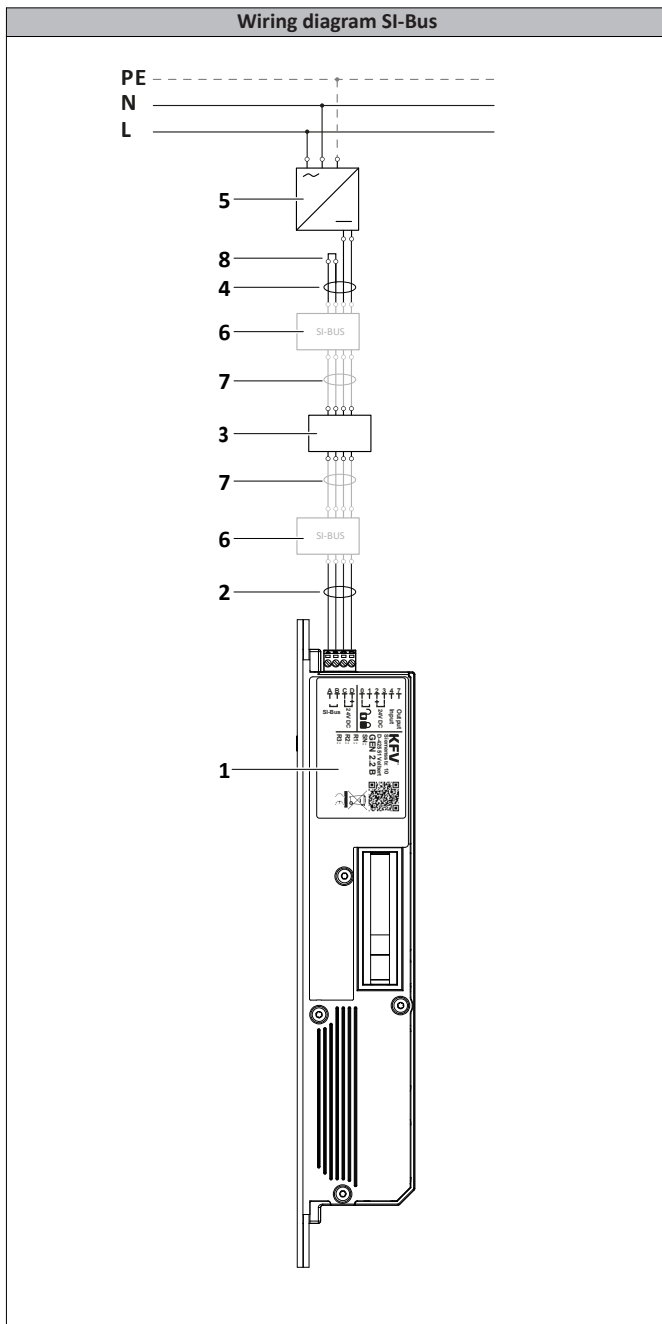

1	Electromechanical drive
2	Cable (SI-Bus, 4-pole PTR plug/ SI-Bus plug)
3	Cable transfer with integrated SI-Bus plug connection
4	Cable (SI-Bus, SI-Bus plug/ power supply connection)
5	Power supply
6	SI-Bus device (e. g.: ACS, IO module Gateway)
7	Cable (SI-Bus, double-sided SI-Bus plug)
8	Connection plug for the termination

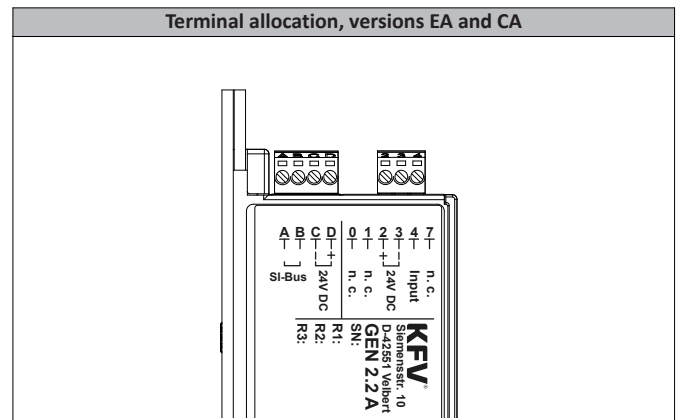

Drive	Terminal	Function	Cable	Colour (band colour)	Identification
	A	SI-BUS		Yellow	0
	B	SI-BUS		Green	1
	C	- GND		brown	-
	D	+ 24 V DC		white	+
	0	Not allocated		-	-
	1	Not allocated		-	-
	2	+ 24 V DC		White (red)	+
	3	- GND		Brown (blue)	-
	4	Input		Green (yellow)	4
	7	Not allocated		-	-
	-	-		Blue (white)	

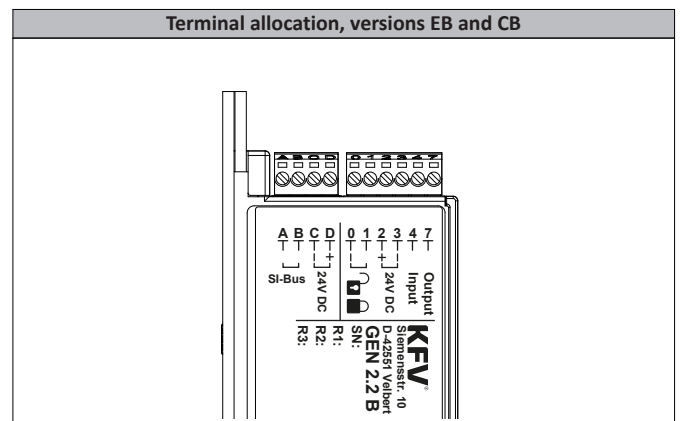

Drive	Terminal	Function	Cable	Colour (band colour)	Identification
	A	SI-BUS		Yellow	0
	B	SI-BUS		Green	1
	C	- GND		brown	-
	D	+ 24 V DC		white	+
	0	Input		Grey (black)	0
	1	Input		Yellow (brown)	1
	2	+ 24 V DC		White (red)	+
	3	- GND		Brown (blue)	-
	4	Input		Green (yellow)	4
	7	Output		Pink (violet)	7
	-	-		Blue (white)	

3.8.2 Analogue connection

Analogue wiring diagram, version EA and CA

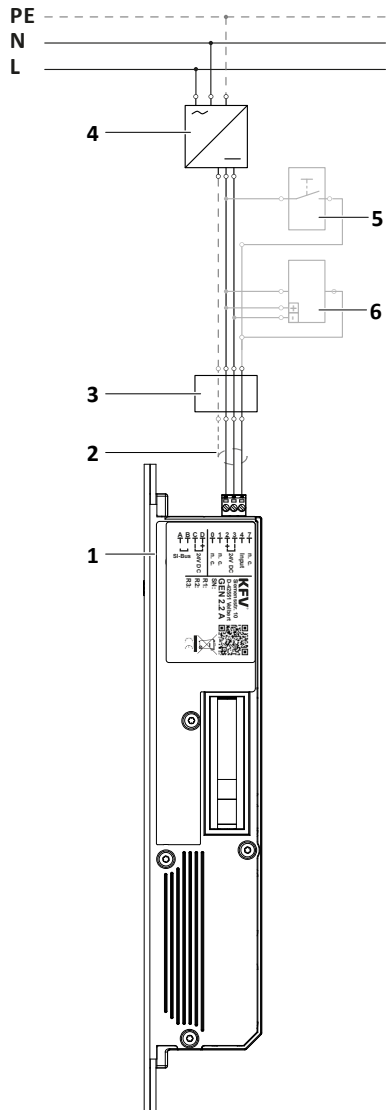

1	Electromechanical drive
2	Adapter cable (analogue, 3-pole PTR plug)
3	Cable transfer
4	Power supply
5	External unlocking
6	External unlocking with separate power supply

Terminal allocation, versions EA and CA

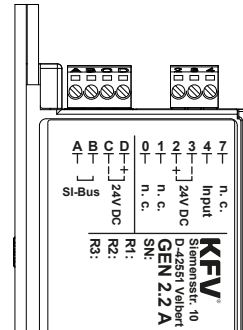

Drive		Cable	
Terminal	Function	Colour (band colour)	Identi- fication
A	SI-BUS	Yellow	0
B	SI-BUS	Green	1
C	- GND	brown	-
D	+ 24 V DC	white	+
0	Not allocated	-	-
1	Not allocated	-	-
2	+ 24 V DC	White (red)	+
3	- GND	Brown (blue)	-
4	Input	Green (yellow)	4
7	Not allocated	-	-
-	-	Blue (white)	

# DRIVE – Assembly instructions

Electromechanical multi-point lock GENIUS 2.2, AS 2xxx EA / EB / CA / CB

**Analogue wiring diagram, version EB and CB**

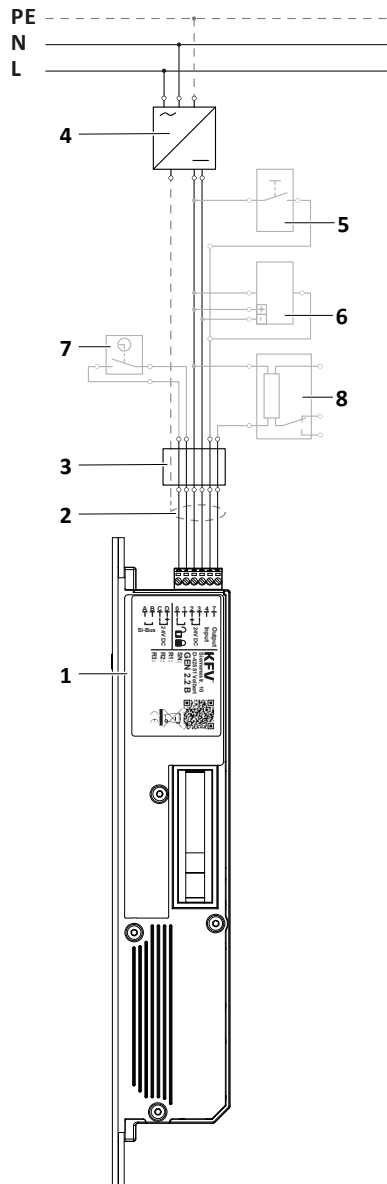

1	Electromechanical drive
2	Adapter cable (analogue, 6-pole PTR plug)
3	Cable transfer

4	Power supply
5	External unlocking
6	External unlocking with separate power supply
7	Clock timer
8	Coupling relay

**Terminal allocation, versions EB and CB**

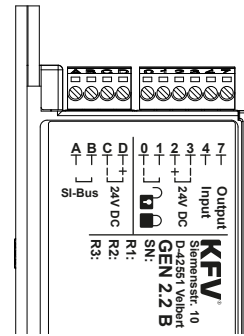

Drive	Cable		
Terminal	Function	Colour (band colour)	Identification
A	SI-BUS	Yellow	0
B	SI-BUS	Green	1
C	- GND	brown	-
D	+ 24 V DC	white	+
0	Input	Grey (black)	0
1	Input	Yellow (brown)	1
2	+ 24 V DC	White (red)	+
3	- GND	Brown (blue)	-
4	Input	Green (yellow)	4
7	Output	Pink (violet)	7
-	-	Blue (white)	

**3.8.3 Analogue connection for smoke protection and fire-rated doors**

**Wiring diagram for smoke protection and fire-rated doors**

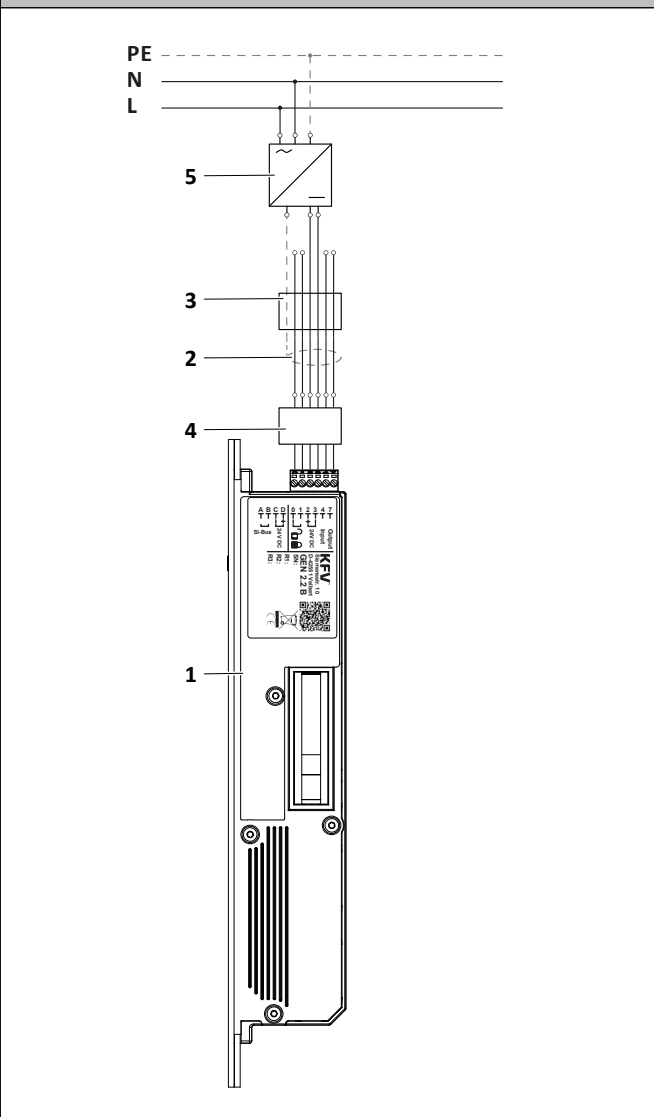

1	Electromechanical drive
2	Fire-resistant cable (6-pole)
3	Cable transfer
4	Emergency power buffer
5	Power supply

**Terminal allocation, versions EB and CB**

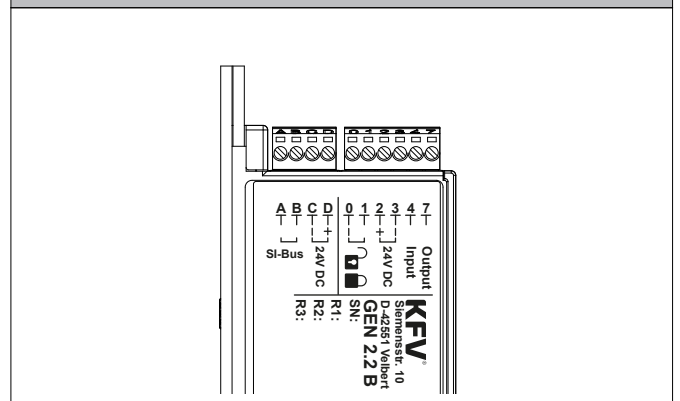

Drive		Cable	
Terminal	Function	Colour (band colour)	Identifi- cation
0	Input	Grey (black)	0
1	Input	Yellow (brown)	1
2	+ 24 V DC	White (red)	+
3	- GND	Brown (blue)	-
4	Input	Green (yellow)	4
7	Output	Pink (violet)	7
-	-	Blue (white)	

## DRIVE – Assembly instructions

Electromechanical multi-point lock GENIUS 2.2, AS 2xxx EA / EB / CA / CB

### 3.9 Technical specifications

Relative humidity (non condensing)	20 - 80 %
Ambient temperature (in accordance with DIN EN 14846 class K, L, N, P)   $T_{UM}$	-25 - +70 °C
Protection class	IP 40
Electrical connection	SI-BUS connection Analogue connection
Operating voltage   $U_B$	24 V DC (19 - 32 V DC)
Protection against polarity reversal   $U_{Verp.}$	-50 V
Communication voltage   $U_{SI-BUS}$	-7 - +12 V
Voltage input terminal 4   $U_{KL4.ON}$	24 V DC (19 - 32 V DC) > 1 s
Operating current standby / standby   $I_{PC}$	30 mA
Operating current for motor control   $I_B$	500 mA (max. 1000 mA)
Current output terminal 7   $I_{KL7}$	≤ 20 mA

### 3.10 Accessories

Name	Characteristic	VE (piece)	Material description	Material number
Cover cap	Protection against ingressing moisture	1	ZEM AK--EE-----16K-----85----EE	3522851

**4 Assembly**

**4.1 Preparation for installation**

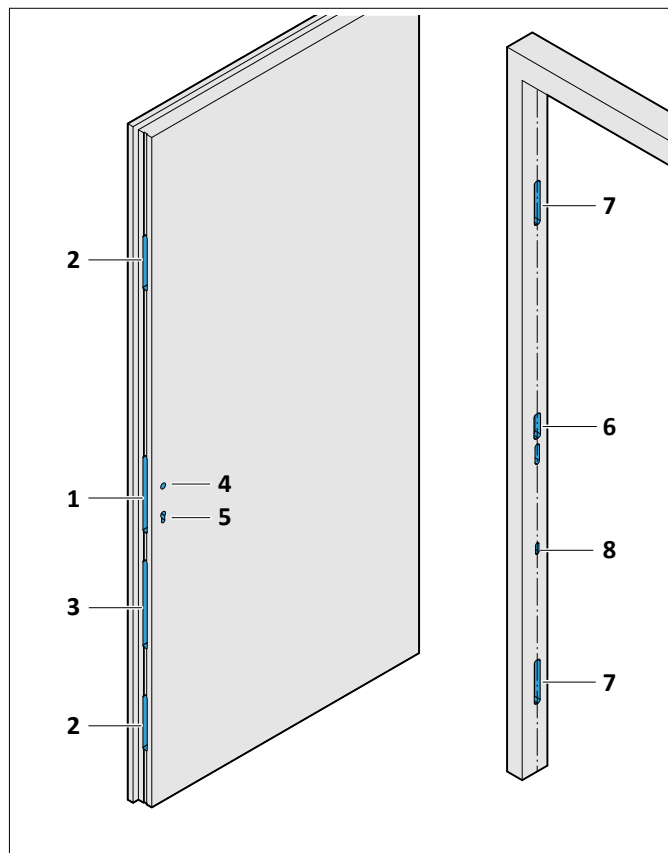



1. Drill and mill the door leaf and door frame according to the dimension specifications and the general tolerances defined in ISO 2768.
2. Remove any splinters from routed pockets after milling.
3. Before installing the product, check the dimensional accuracy of the door and the door frame. Do not install the product in event of warping or damage.
4. Check the product for damage. Do not install the product if it is bent or damaged.
5. Route the cable for power supply to the drive from the hinge side of the door leaf to the product without kinks.
6. If need be, insert the oval magnet bush into the striker plate series 23xx without backing with the magnet facing upwards.







1	Milling for main lock case (see page 24)
2	Milling for auxiliary box (see page 24)
3	Milling for drive (see page 25)
4	Hole for lever handle (see page 25)
5	Milling for profile cylinder (see page 26)
6	Milling for main striker plate (see page 26)
7	Milling for additional striker plate (see page 27)
8	Milling for magnet (see page 27)

## DRIVE – Assembly instructions

Electromechanical multi-point lock GENIUS 2.2, AS 2xxx EA / EB / CA / CB

### 4.2 Tooling and work equipment

Tooling	
	Cross screwdriver PZD2
	Torx angle wrench T10

Work equipment		Intended use
	Screw Ø 3.9 mm	PVC min. 2 mm wall thickness
	Screw Ø 4.8 mm	PVC SKG** min. 2 mm wall thickness
	Screw Ø 4.0 mm	Timber
	Screw Ø 4.0 mm x 40 mm	Timber SKG**
	Screw Ø 4.5 mm x 45 mm	Timber SKG*** SKH certified
	Screw Ø 3.9 mm	Metal steel reinforcement min. 1.5 mm wall thickness
	Screw Ø 4.2 mm	Metal SKG** steel reinforcement min. 1.5 mm wall thickness

**4.3 Assembly of sash components**

**4.3.1 Change DIN orientation of the main lock latch**

1. Compare the DIN orientation of the door with the latch and change over the latch if necessary.
2. Insert the screwdriver through the hole at the rear of the gear box.

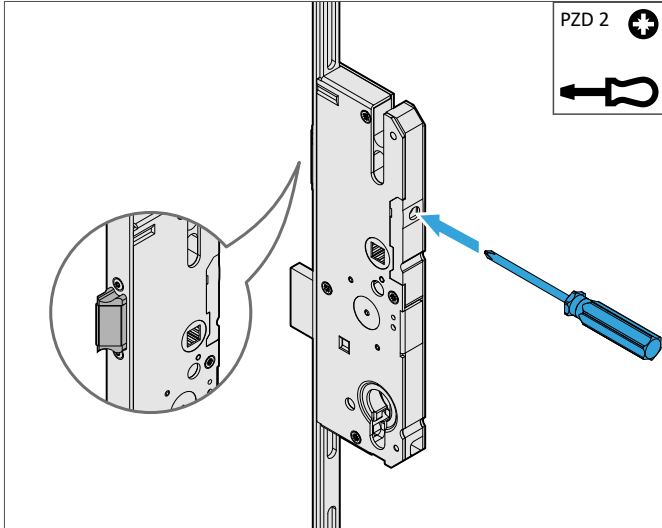

3. Loosen the locking screw of the latch shaft and remove the latch.

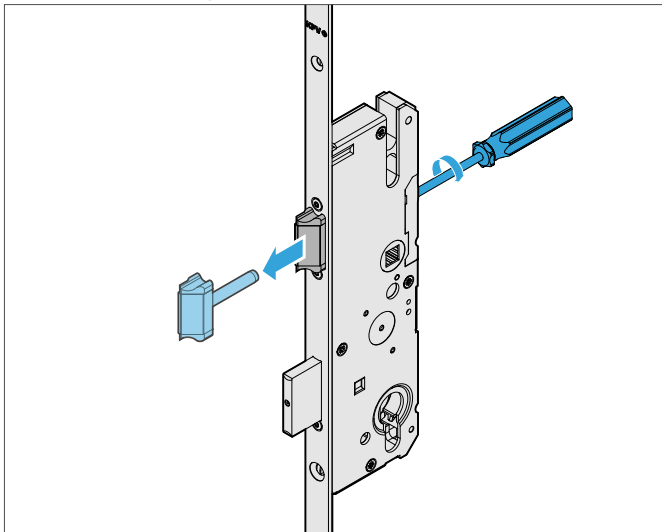

4. Turn the latch by 180° and press into the gear box.

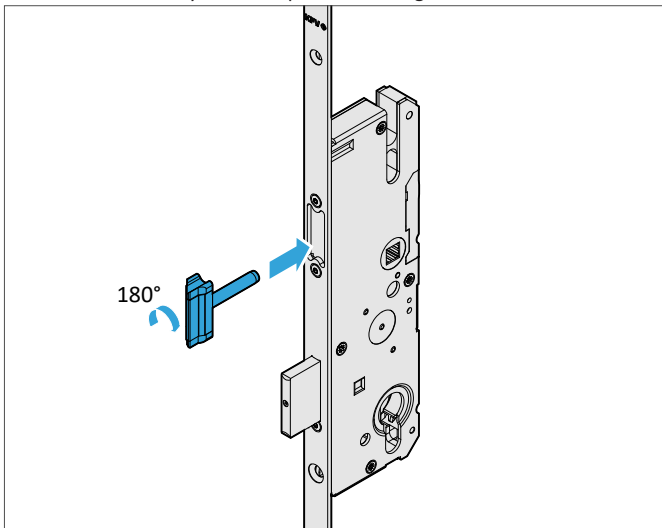

5. Tighten the locking screw of the latch shaft with the screwdriver.

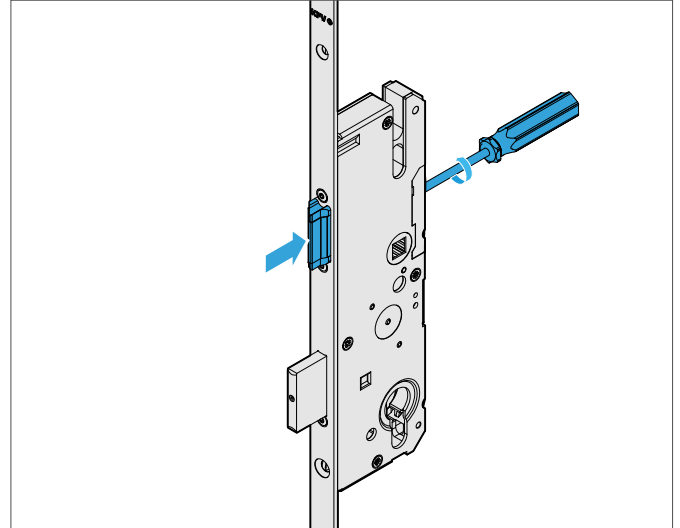

6. Press the latch into the gear box several times.

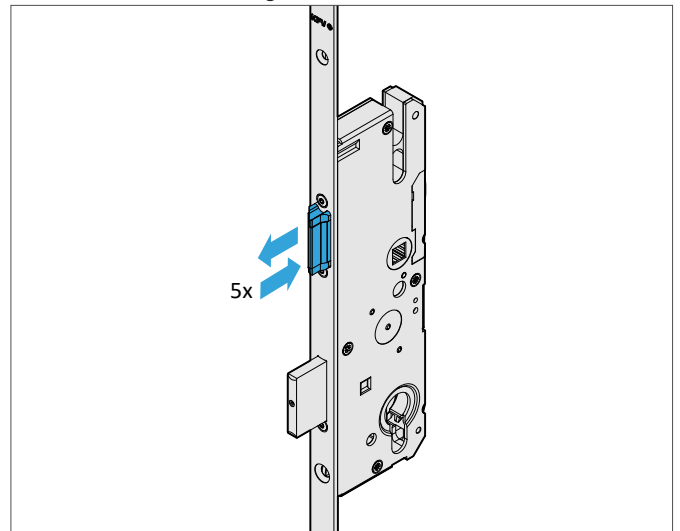

7. Check that the latch moves smoothly and independently.

## 4.3.2 Screwing the multi-point lock into place

### ! NOTICE

#### Material damage due to ingressing liquid

An ingress of liquid into the drive can lead to short circuit.

- Mount the cover cap to protect against ingressing liquid.
- Observe the IP protection class.

#### Prerequisite

- The cables are routed through the door leaf.
1. Connect the cable to the drive. If necessary, mount the cover cap to the electrical connection of the drive.
  2. Guide the cable into the routed pocket avoiding any kinks.

3. Insert the multi-point lock in the milled door leaf.

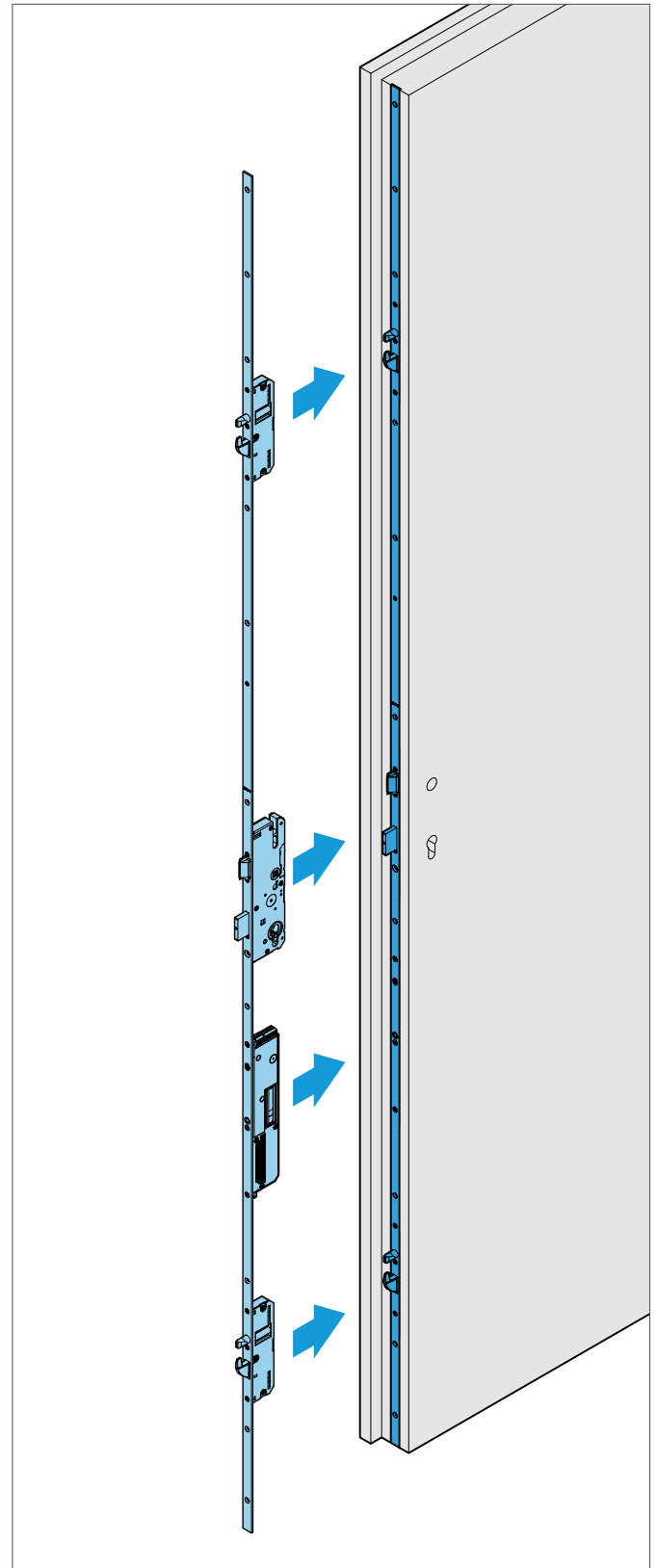

4. Adjust the multi-point lock so that the handle spindle is centred to the hole.

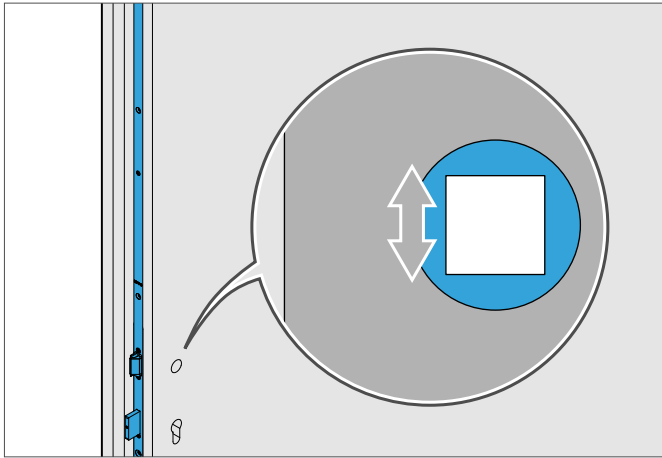

5. Screw the multi-point lock to the door leaf.

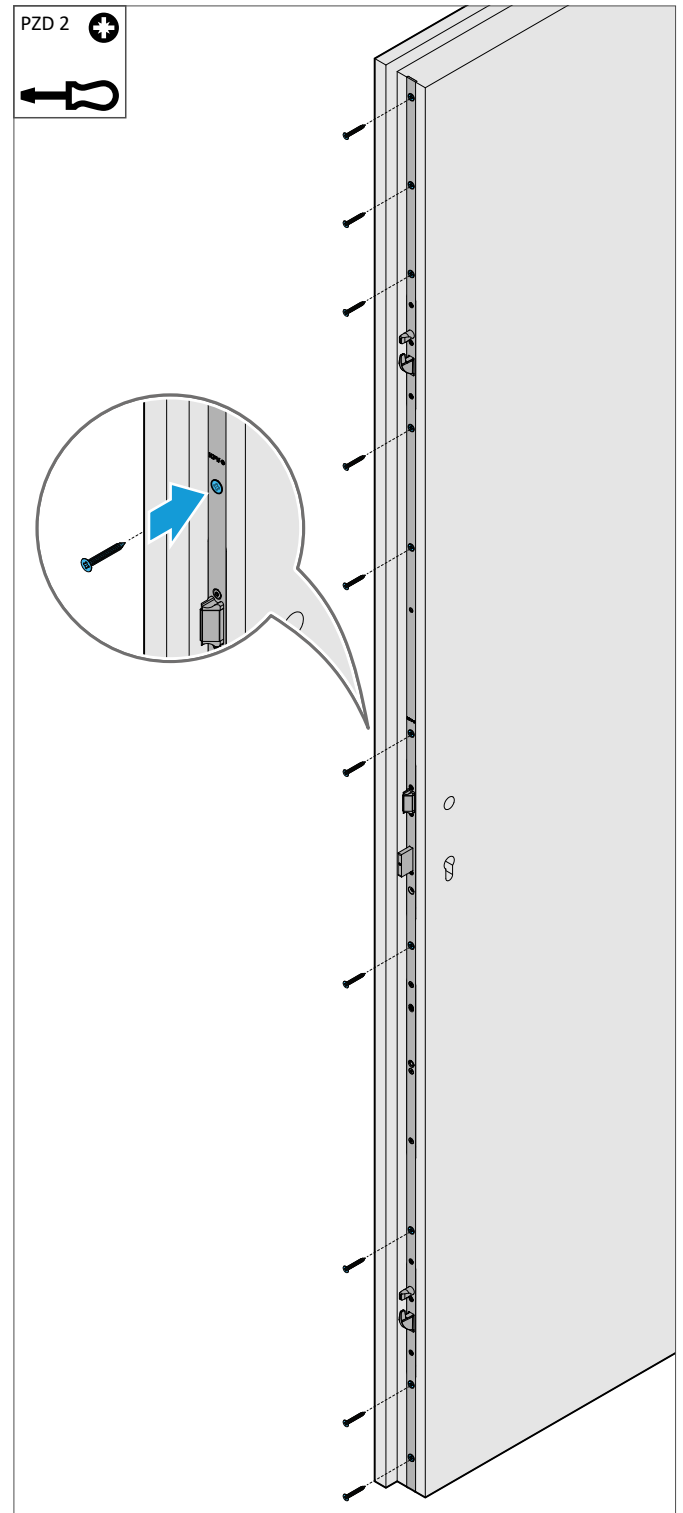

### 4.3.3 Assembly of handle set and cylinder lock

#### NOTICE

##### **Material damage due to improper assembly**

You will damage the multi-point lock if you do not install the handle set properly.

- Once the gear box is installed, do not drill through the door leaf.
- Do not knock the square spindle of the lever handle into the locking groove with force.

1. Install the handle set and the cylinder lock according to the producer's instructions.

## 4.4 Assembling the frame parts

### 4.4.1 Screw on striker plates

1. Insert the frame parts into the milled door frame.

2. Screw the striker plates to the door frame.

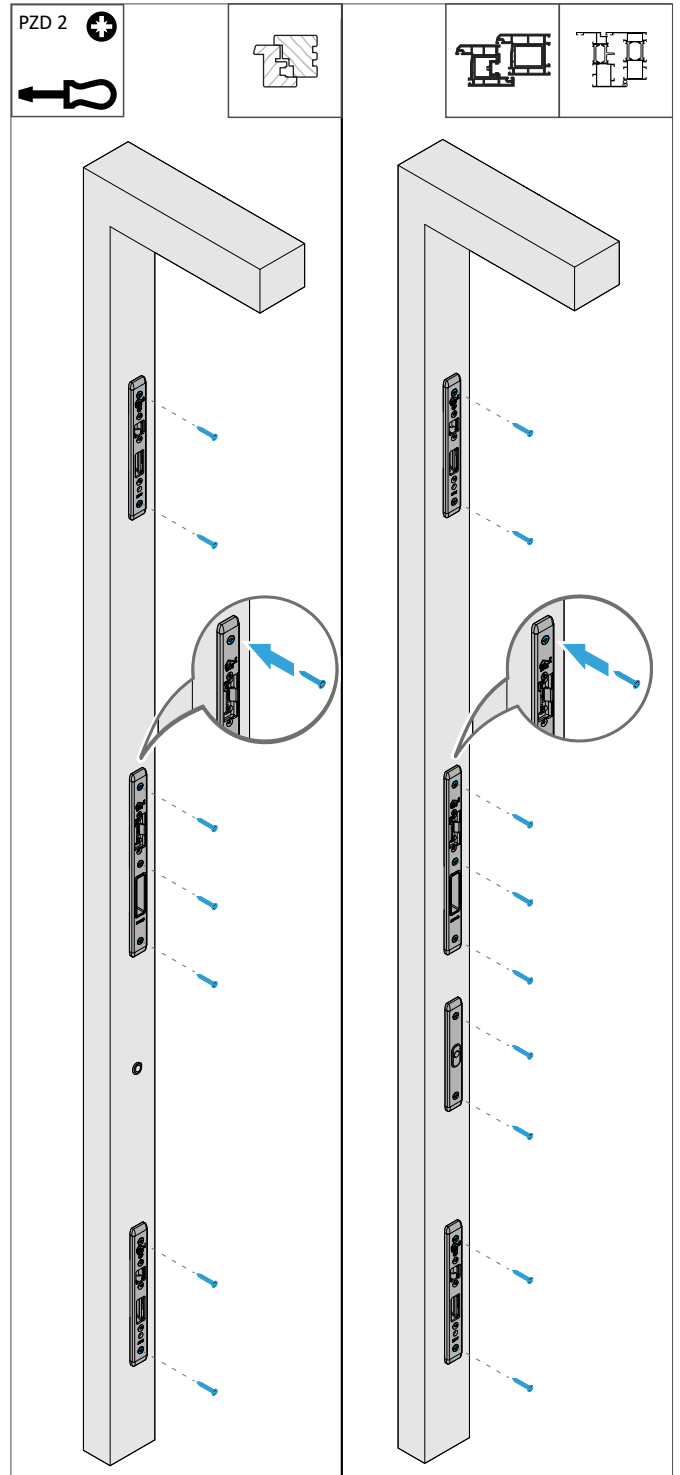
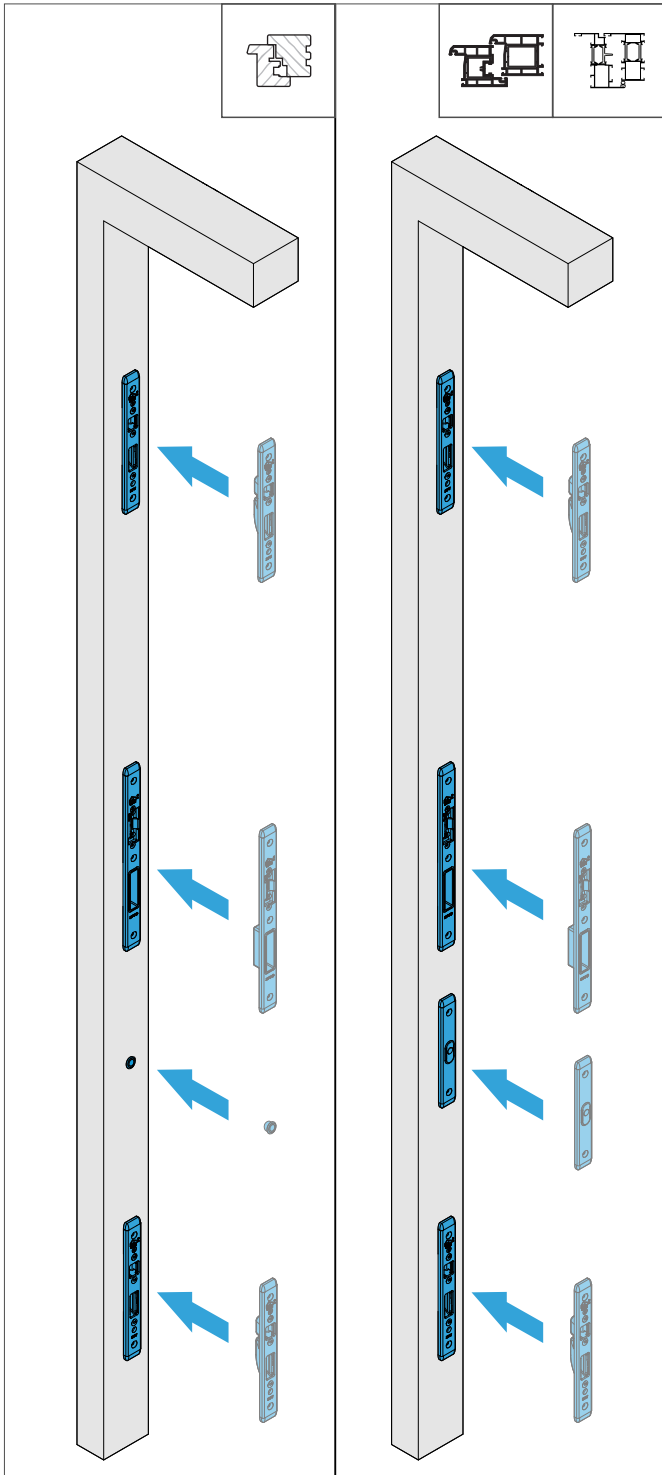

### 4.4.2 Screw on locking rail

1. Insert the locking rail into the milled door frame.

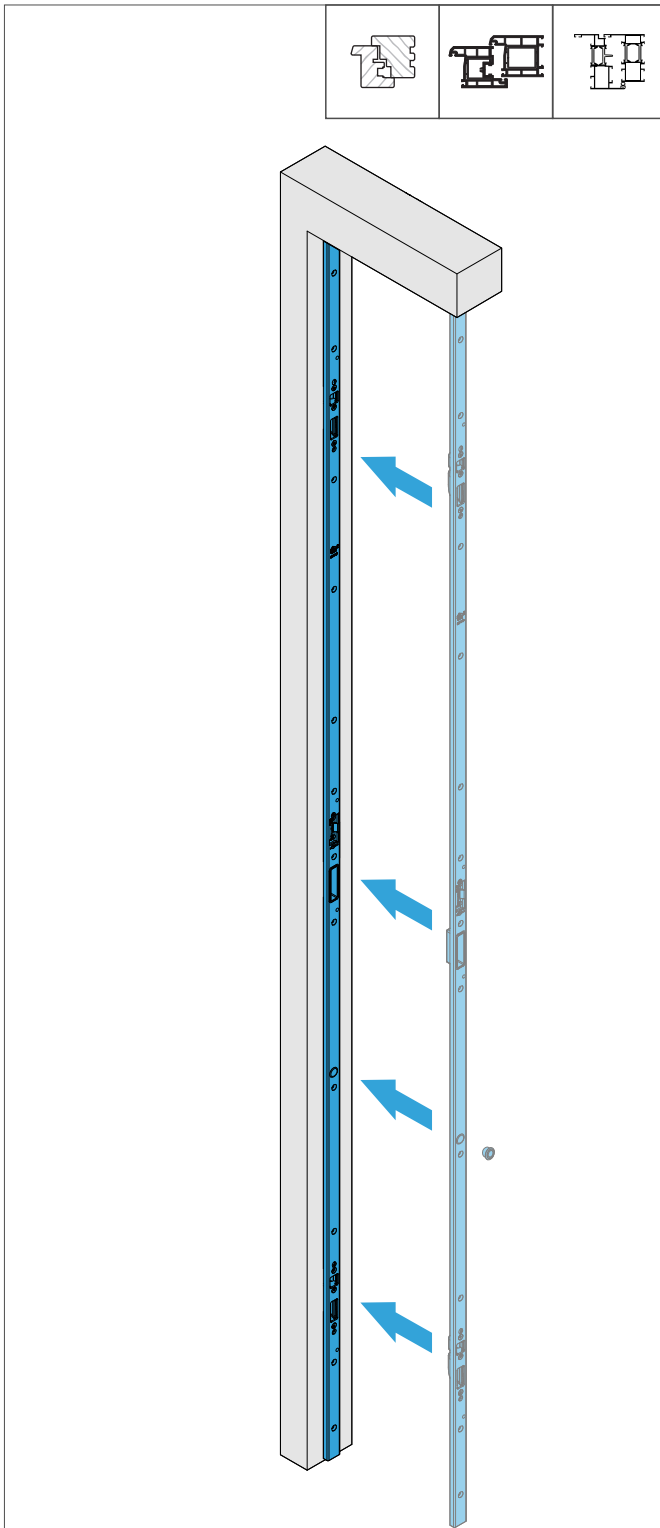

2. Screw the locking rail to the door frame.

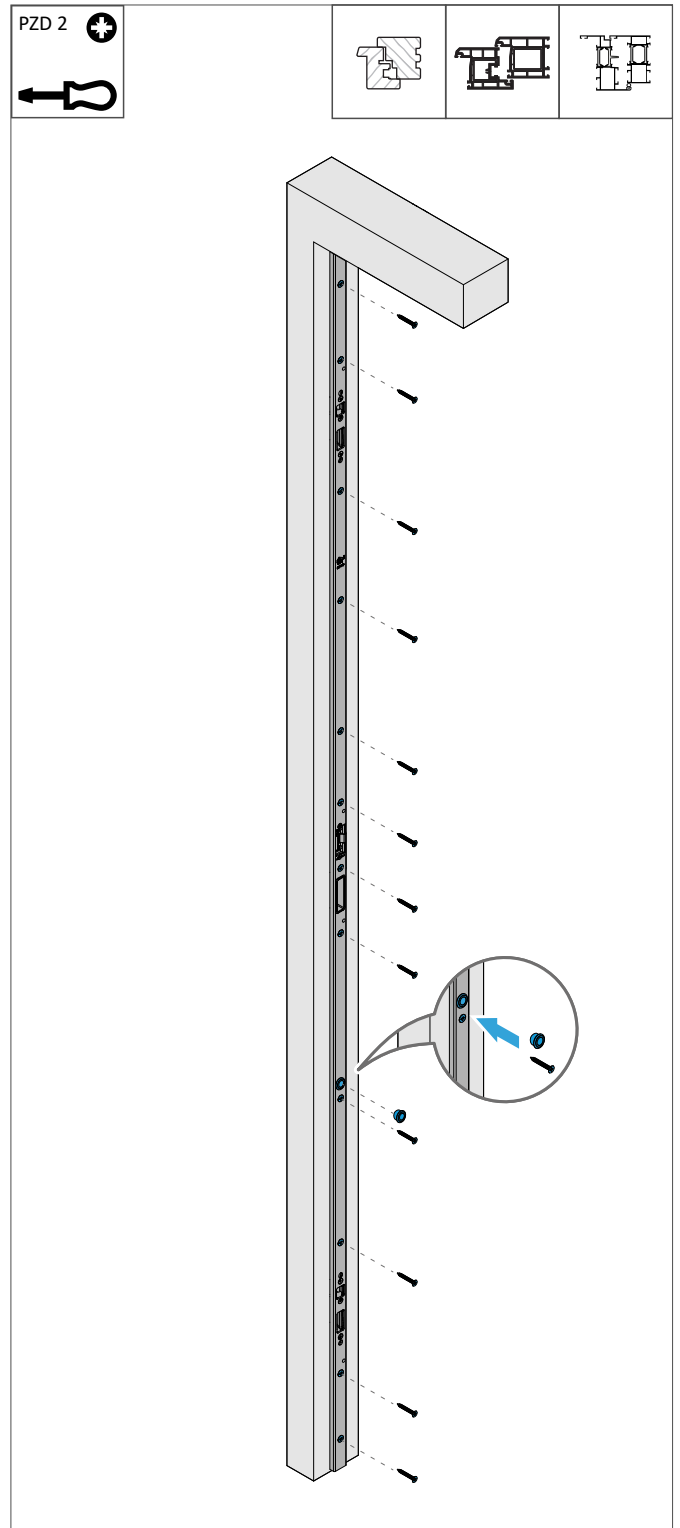

## 5 Commissioning

### 5.1 Adjusting the residual airgap

The function of the multi-point lock is guaranteed for the defined residual airgap.

1. Follow the assembly instructions of the producer of the door hinge.

2. Adjust the residual airgap between secondary sash and frame part.

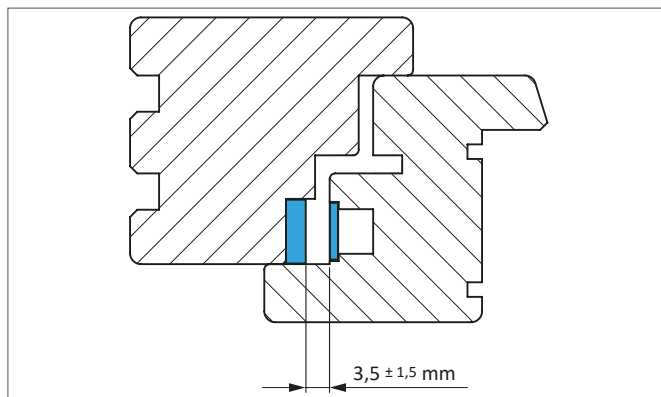

### 5.2 Adjustment of the frame parts

#### Position of the frame parts

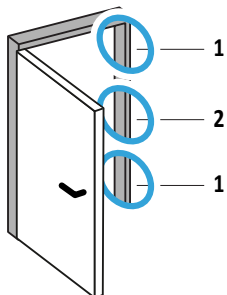

1. Adjust the pressure on the door seal via the replacement part and the Q adjustments in the frame parts.

1	Q adjustments
2	Replacement part

## DRIVE – Assembly instructions

Electromechanical multi-point lock GENIUS 2.2, AS 2xxx EA / EB / CA / CB

### 5.2.1 Reduce the pressure on the door seal

#### Prerequisites

- The door does not close.
- The door does not lock.

1. Loosen the two adjustment screws of the replacement part.

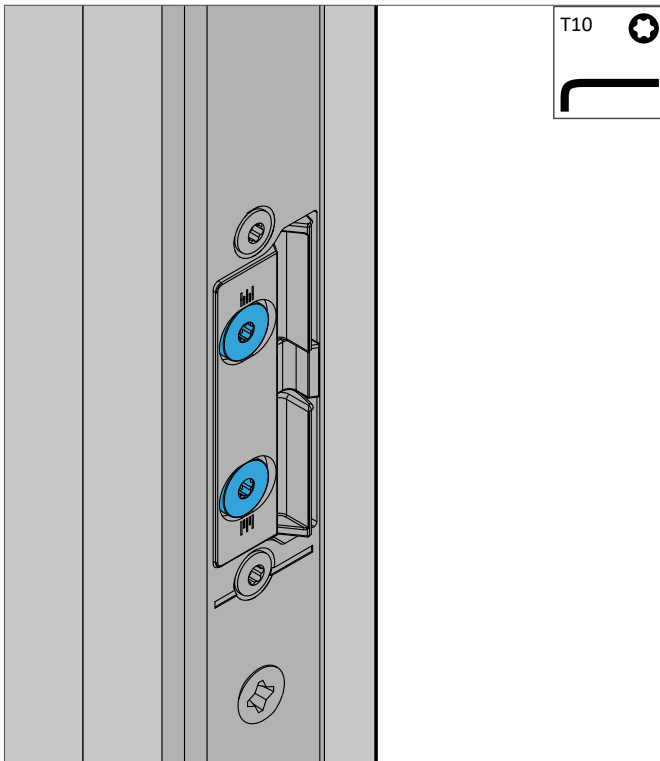

2. Adjust the replacement part in the direction of the door leaf.

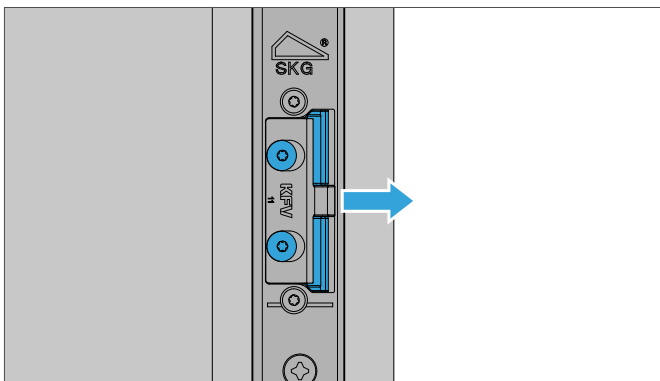

3. Tighten the two adjustment screws.

4. Loosen the 3 fixing screws of the Q-adjustment.

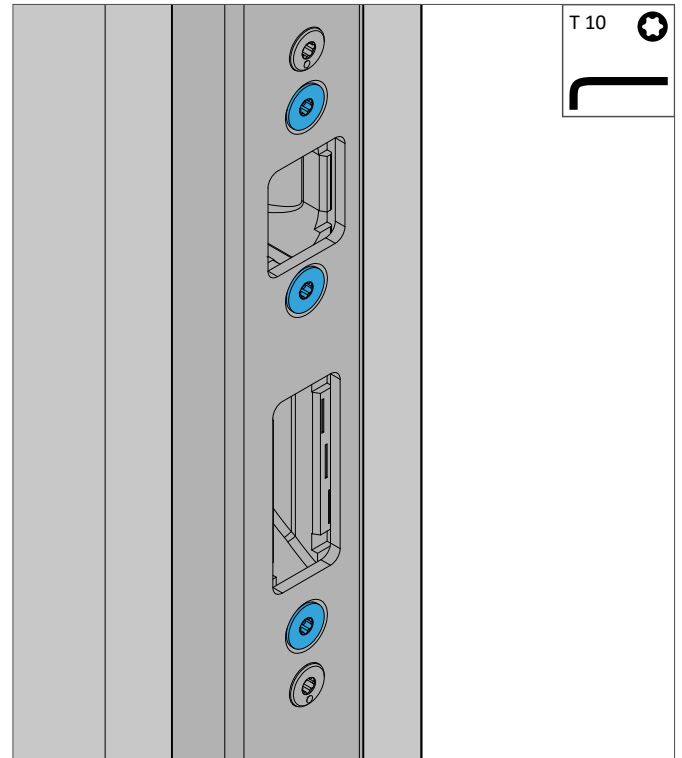

5. Turn both eccentric screws max. 90° from the neutral position (marking pointing downwards) in an anti-clockwise direction.

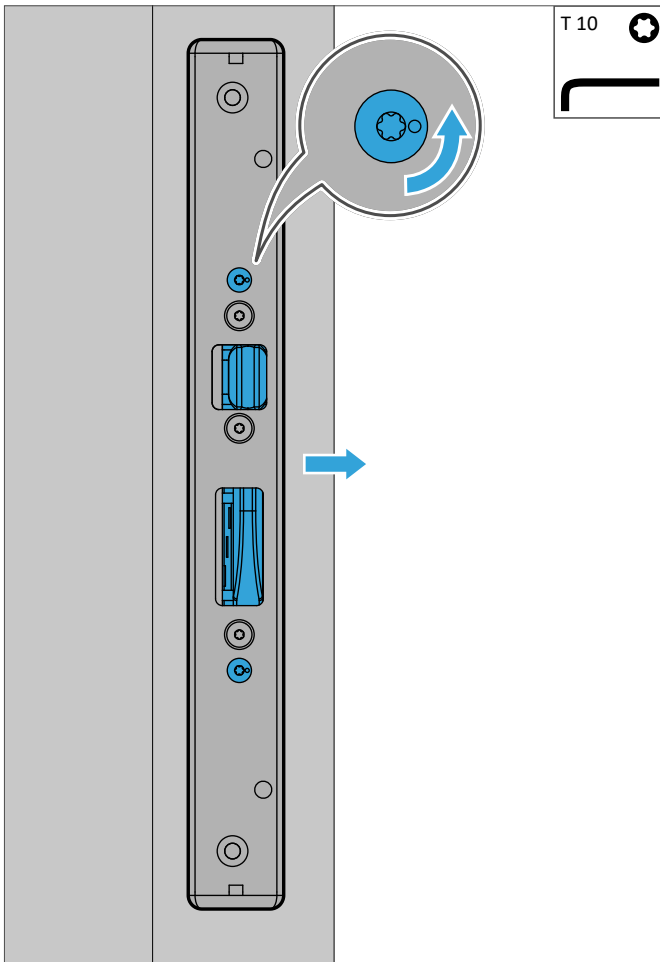

→ The Q-adjustment moves up to 2.5 mm in the direction of the door leaf.

6. Tighten the 3 fixing screws of the Q-adjustment.
7. Check that the door closes and locks. Repeat these steps if the door does not close and lock.

## DRIVE – Assembly instructions

Electromechanical multi-point lock GENIUS 2.2, AS 2xxx EA / EB / CA / CB

### 5.2.2 Increase the pressure on the door seal

#### Prerequisites

- The door closes with play.
- The door locks with play.

1. Loosen the two adjustment screws of the replacement part.

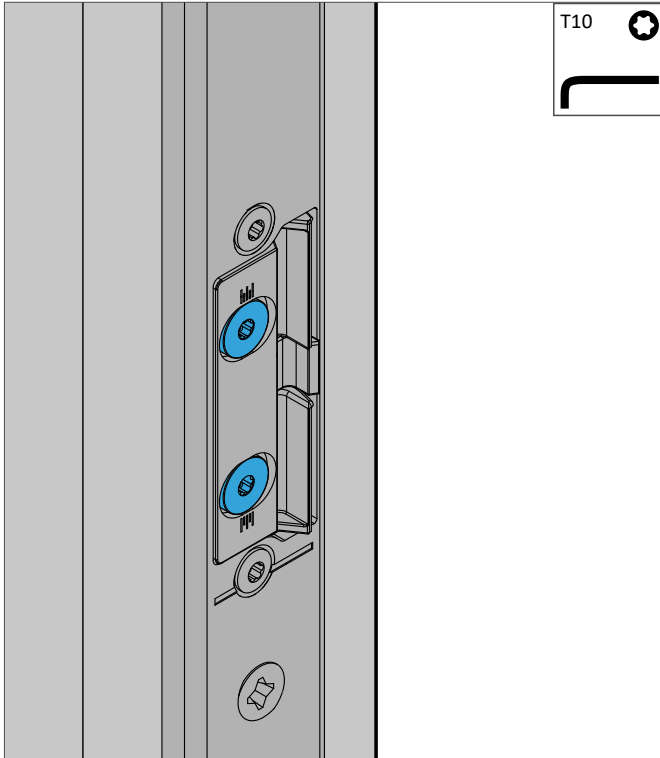

2. Adjust the replacement part in the direction of the door frame.

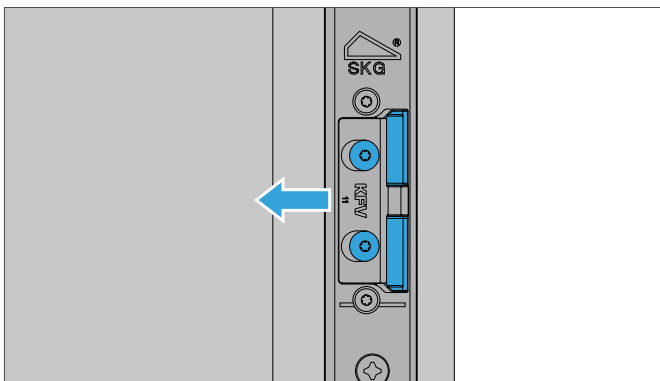

3. Tighten the two adjustment screws.

4. Loosen the 3 fixing screws of the Q-adjustment.

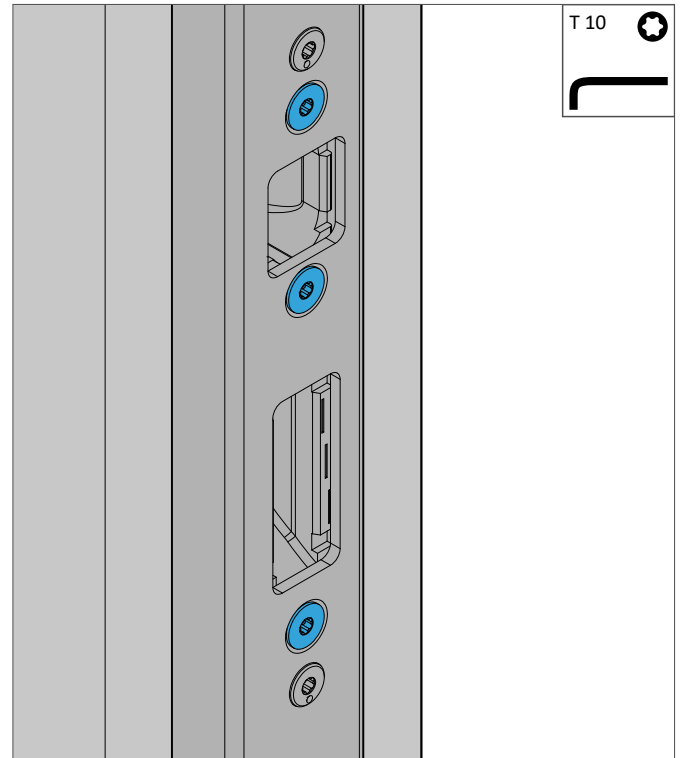

5. Turn both eccentric screws max. 90° from the neutral position (marking pointing downwards) in a clockwise direction.

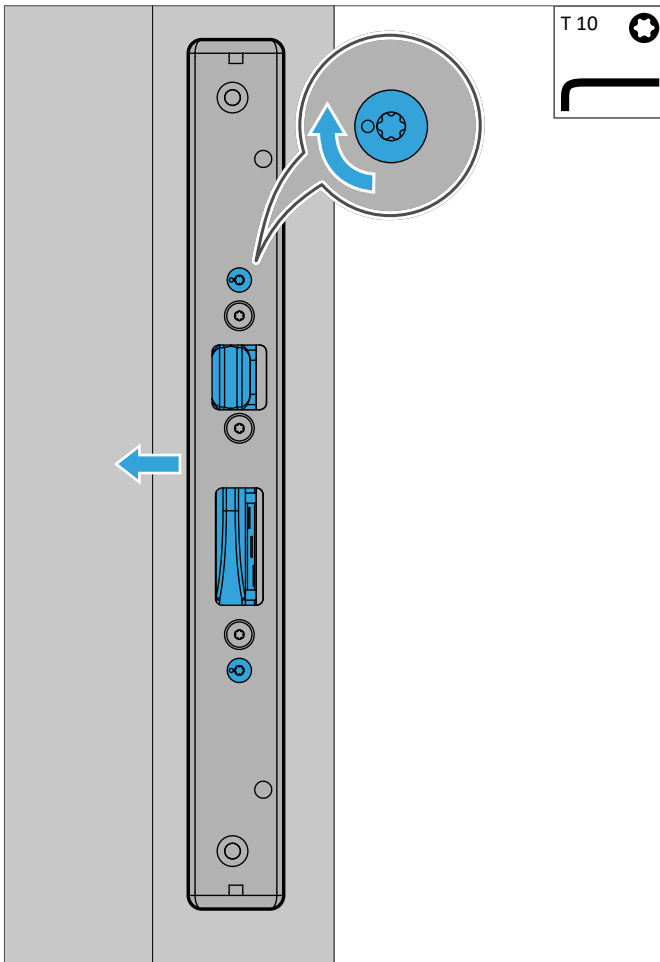

→ The Q-adjustment moves up to 2.5 mm in the direction of the door frame.

6. Tighten the 3 fixing screws of the Q-adjustment.
7. Check that the door closes and locks without play. Repeat these steps if the door closes and locks with play.

## DRIVE – Assembly instructions

Electromechanical multi-point lock GENIUS 2.2, AS 2xxx EA / EB / CA / CB

### 5.3 Functional test

#### 5.3.1 Check the latch function

##### Prerequisite

- the door is open.

1. Press the lever handle downwards until you reach the stop.
2. Check that the main lock latch retracts smoothly and fully.

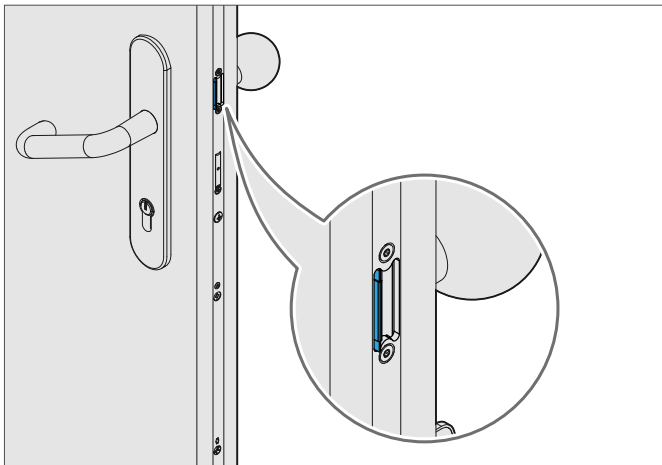

3. Release the lever handle.

4. Check that the lever handle retracts independently.

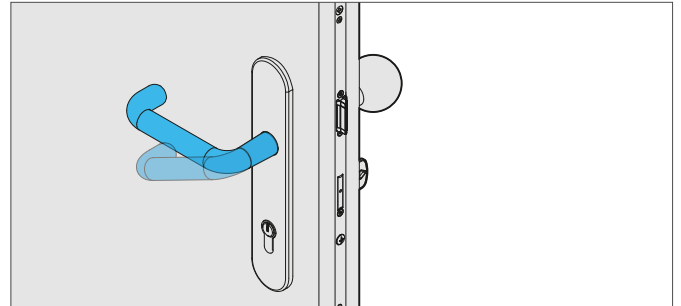

5. Check that the main lock latch extends fully.

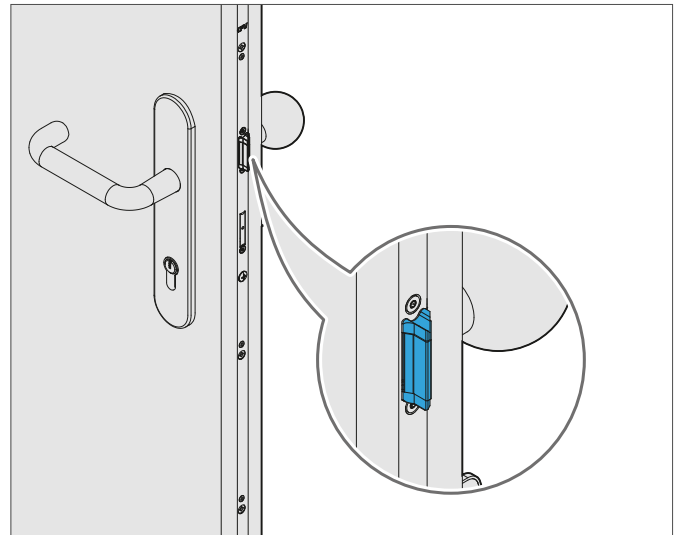

**5.3.2 Check the door function**

**Prerequisite**

- The door is open and the multi-point lock is in day mode.

1. Close the door.

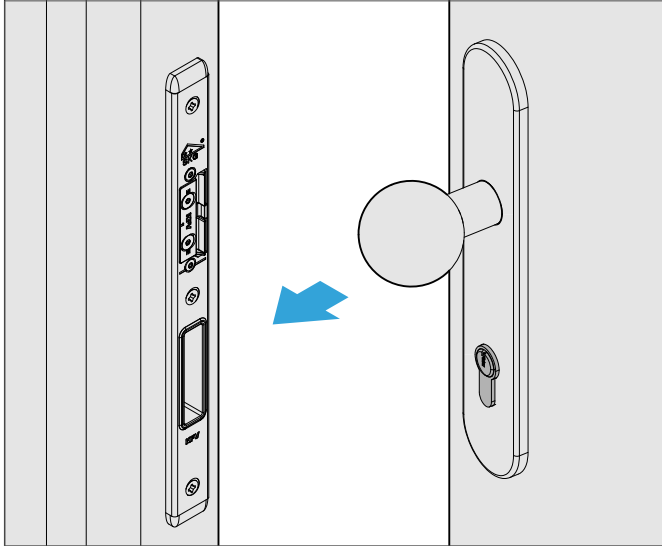

2. Check that the door closes smoothly and the latch engages in the replacement part.
3. Press the lever handle downwards until you reach the stop.
4. Check that the lever handle can be moved smoothly.
5. Check that the door can be opened smoothly.

**5.3.3 Check the cylinder operated lock**

**Prerequisite**

- The door is open and the multi-point lock is in day mode.

1. Turn and hold the key in the unlocking direction.

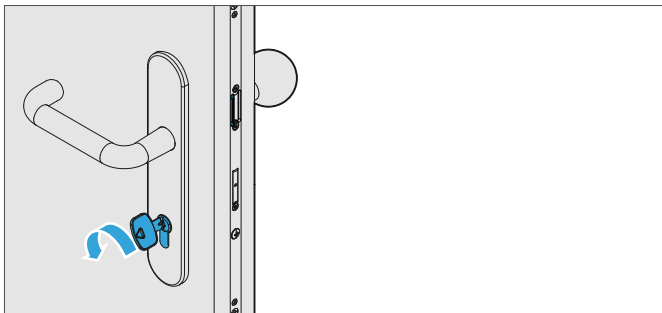

2. Check that the main lock latch retracts fully.

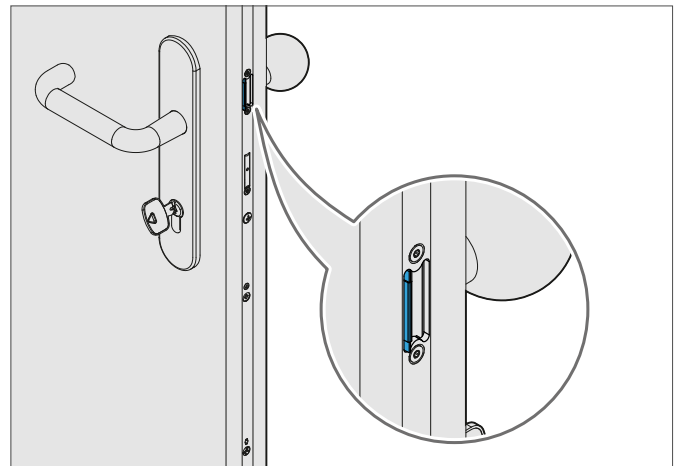

3. Release the key.

## DRIVE – Assembly instructions

Electromechanical multi-point lock GENIUS 2.2, AS 2xxx EA / EB / CA / CB

4. Check that the main lock latch extends fully.

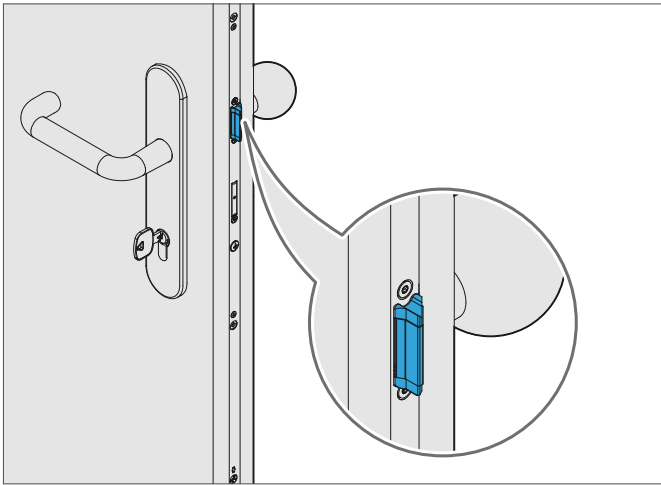

5. Close the door.
6. Open the door with the key.
7. Check that the door can be opened smoothly.

### 5.3.4 Checking the locking elements

#### Prerequisite

- the door is open.

1. Turn the key in the locking direction as far as the stop.
2. Check that the main lock bolt extends smoothly and fully.

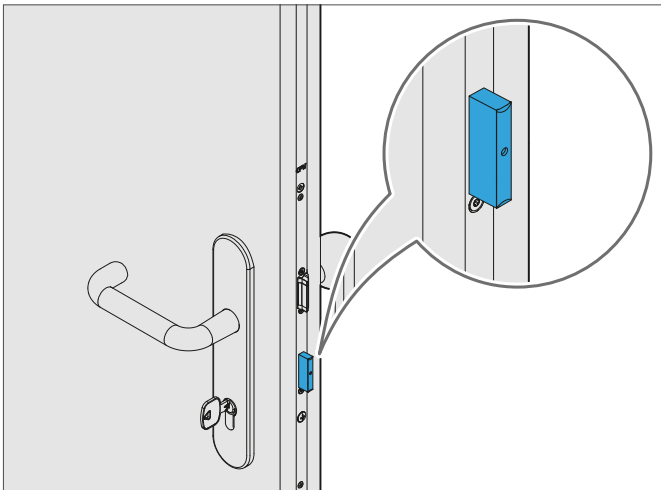

3. Check that the hook bolt and bolt extend smoothly and fully.

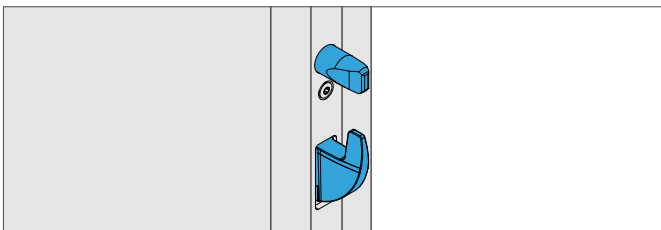

4. Press against the deadbolt.

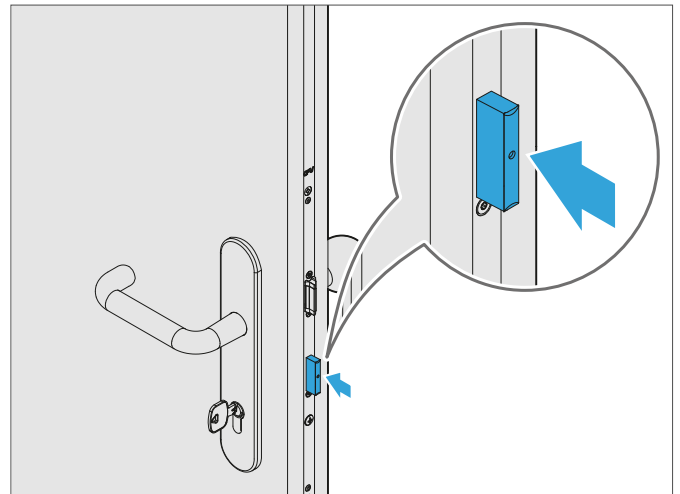

5. Check that the main lock bolt cannot be pressed back.
6. Press against the hook bolt and the bolt.

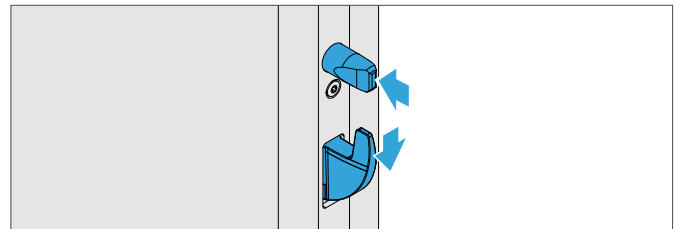

7. Check that the hook bolt and bolt cannot be pressed back.
8. Withdraw the key.
9. Check whether the lever handle is blocking in versions EA and EB.
10. In versions EA and EB, insert the key into the cylinder lock and turn in the release direction.

11. In versions CA and CB, move the lever handle down to the stop.

12. Check that the deadbolt retracts smoothly and fully.

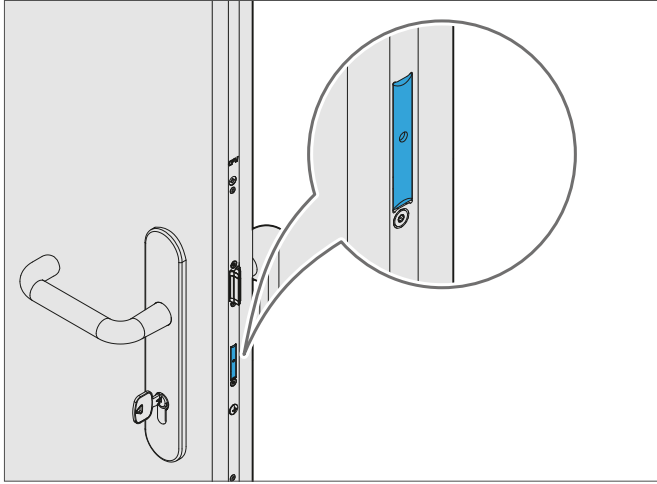

13. Check that the hook bolt and bolt retract smoothly and fully.

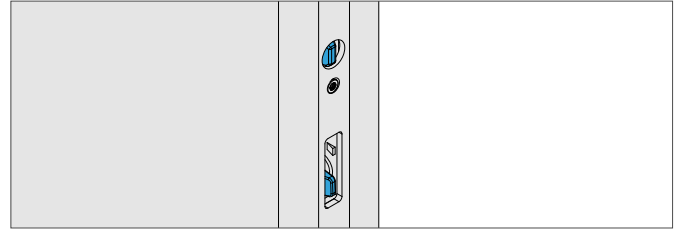

### 5.3.5 Check automatic locking part

**For version EA and EB:**

**Prerequisite**

- the door is open.

1. Switch the multi-point lock to night mode (see page 15).
2. Close the door.
3. Check that the door is locked.
4. If a key is stuck in the cylinder lock, remove the key.
5. Check whether the lever handle is blocking.
6. Release the door with the key.
7. Check that the door opens smoothly and that the lever handle is no longer blocking.

**For version CA and CB:**

**Prerequisite**

- the door is open.

1. Switch the multi-point lock to night mode (see page 15).
2. Close the door.
3. Check that the door is locked.
4. Press the lever handle downwards until you reach the stop.
5. Check that the door opens smoothly.

## DRIVE – Assembly instructions

Electromechanical multi-point lock GENIUS 2.2, AS 2xxx EA / EB / CA / CB

### 5.3.6 Check manual locking part

#### For version EA and EB:

##### Prerequisite

- the door is open.

1. Switch the multi-point lock to day mode (see page 15).
2. Close the door and lock with the key.
3. Check that the door is locked.
4. Withdraw the key.
5. Check whether the lever handle is blocking.
6. Release the door with the key.
7. Check that the door opens smoothly.
8. Check that the lever handle is no longer blocking.

#### For version CA and CB:







##### Prerequisite

- the door is open.

1. Switch the multi-point lock to day mode (see page 15).
2. Close the door and lock with the key.
3. Check that the door is locked.
4. Withdraw the key.
5. Press the lever handle downwards until you reach the stop.
6. Check that the door opens smoothly.

## 5.4 Adjustment of menu functions

### 5.4.1 Adjustment of volume

Menu level 1	Menu level 2	value
		100 % volume
		75 % volume
		<b>50 % volume (default setting)</b>
		25 % volume
		0 % volume

##### Prerequisites

- The status LED lights up green.
- The LED button lights up white in day mode or blue in night mode.

1. Press the LED button if no LEDs light up.

- To change to menu level 1, press and hold down the LED button for 8 seconds until it light up magenta and emits an acoustic signal.

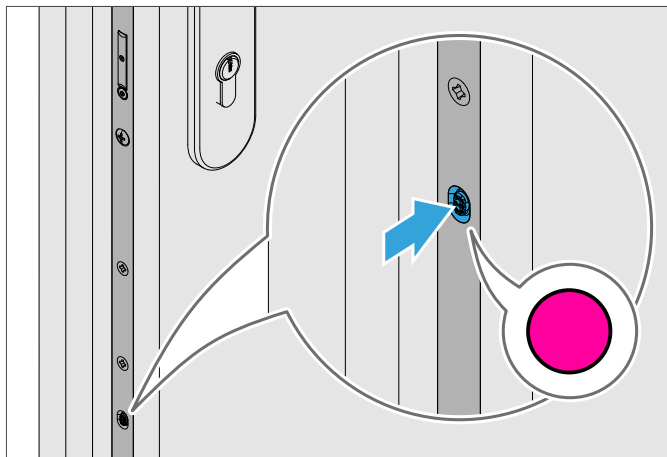

- To select the desired volume, press the LED button according to the scheme.

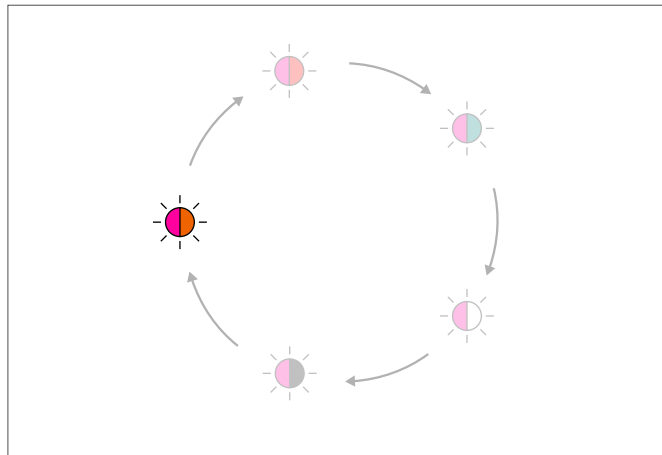

- To change to menu level 2, press and hold down the LED button for 3 seconds.  
→ In the menu level 2 the adjusted value flashes first.

- Hold down the LED button for 3 seconds to save the selected function.

**5.4.2 Adjustment of day / night mode changeover**

Menu level 1	Menu level 2	Function			
		value	LED button	Connection to terminal 1	Additional function
●	☀	1	–	–	–
	☀	2	–	●	–
	☀	3	●	-	–
	☀	4 (default setting)	●	●	–
	☀	5	●	●	Single switchover between Day and Night mode is possible
	☀	6	●	●	Single switchover from night mode to day mode and back to night mode again is possible

Symbol	Explanation
●	Standard version
○	Optional or alternative version
-	not available

- Press the LED button if no LEDs light up.

**Prerequisites**

- The status LED lights up green.
- The LED button lights up white in day mode or blue in night mode.

## DRIVE – Assembly instructions

Electromechanical multi-point lock GENIUS 2.2, AS 2xxx EA / EB / CA / CB

2. To change to menu level 1, press and hold down the LED button for 8 seconds until it lights up magenta and emits an acoustic signal.

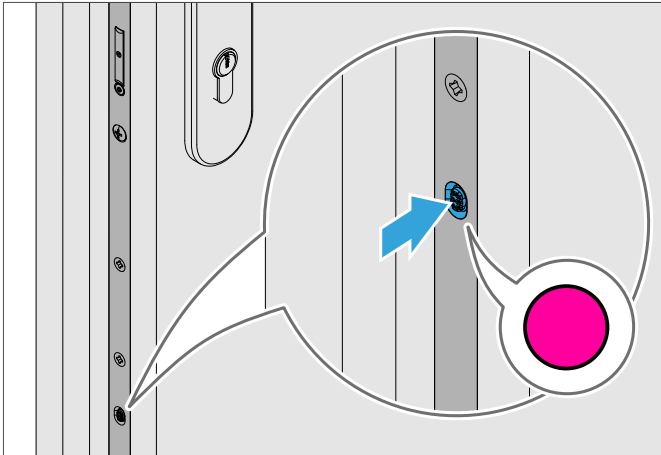

3. To adjust the functions of the day / night changeover, press the LED button until it lights up light green.
4. Press the LED button 1x for versions EA or CA.

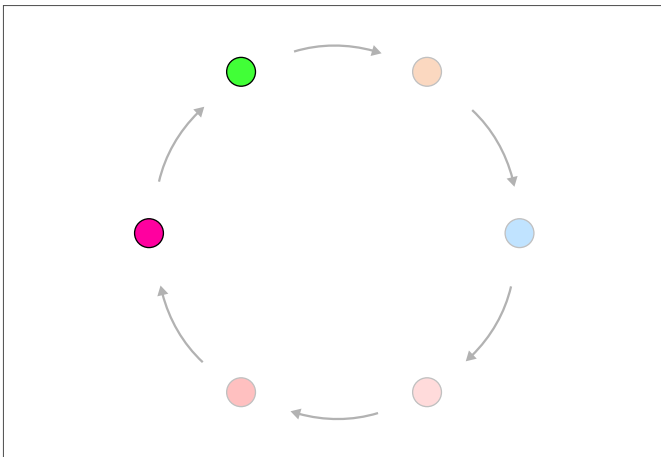

5. Press the LED button 3x for versions EB or CB.

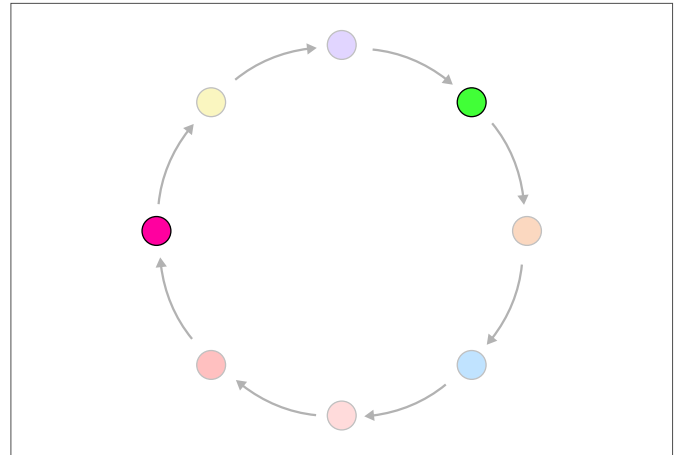

6. To change to menu level 2, press and hold down the LED button for 3 seconds.  
→ In the menu level 2 the adjusted value flashes first.
7. To select the desired function, press the LED button according to the scheme.

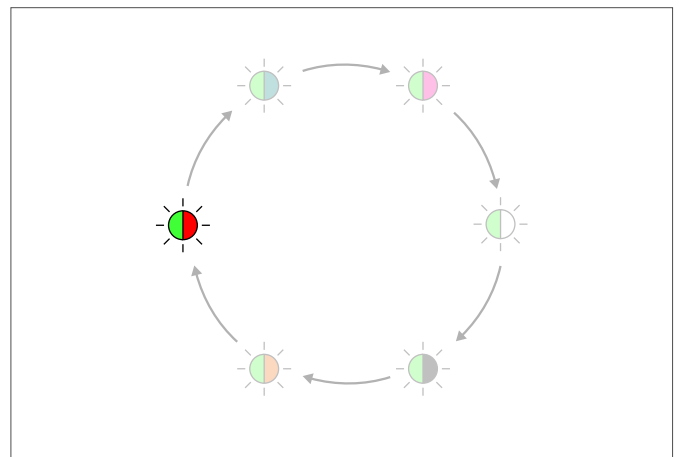

8. Hold down the LED button for 3 seconds to save the selected function.

**5.4.3 Adjustment of the status feedback function (for versions EB and CB)**

The function is only available in versions EB or CB.

Menu level 1	Menu level 2	Function	
		value	status
●		<b>A (Default setting)</b>	The door is closed and locked.
		B	In day mode: the door is closed In night mode: the door is closed and locked.
		C	The latch is retracted
		D	Active error. The latch is retracted. The multi-point lock is in the locking process or in the unlocking process. The door is closed and locked. The door is closed and not locked.
		E	The door is released.
		F	No active error.

**Prerequisites**

- The status LED lights up green.
- The LED button lights up white in day mode or blue in night mode.

1. Press the LED button if no LEDs light up.
2. To change to menu level 1, press and hold down the LED button for 8 seconds until it light up magenta and emits an acoustic signal.

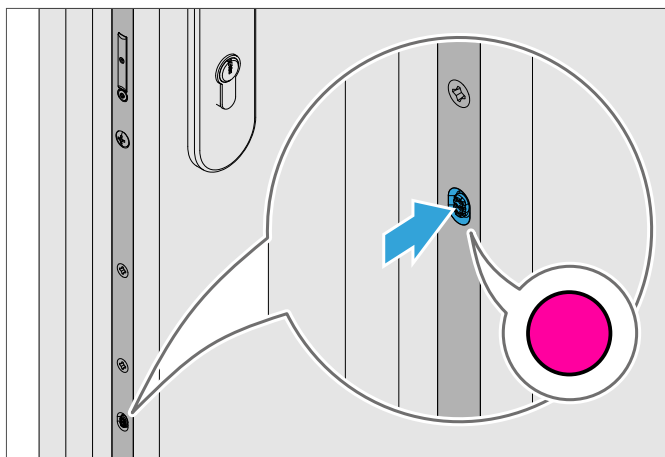

3. To adjust the functions of the status feedback, press the LED button 1x until it lights up yellow.

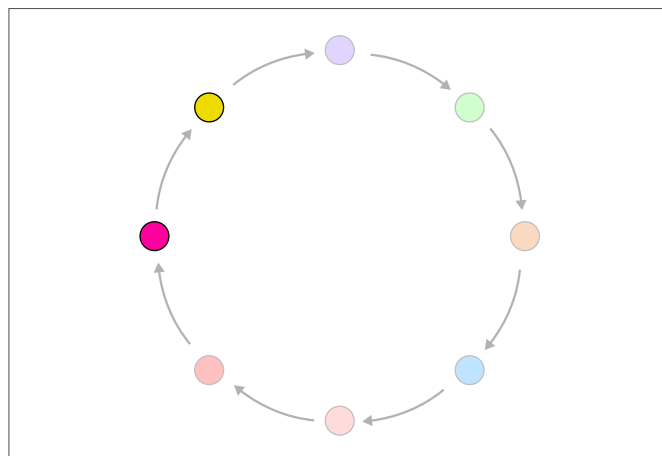

4. To change to menu level 2, press and hold down the LED button for 3 seconds.  
→ In the menu level 2 the adjusted value flashes first.
5. To select the desired function, press the LED button according to the scheme.

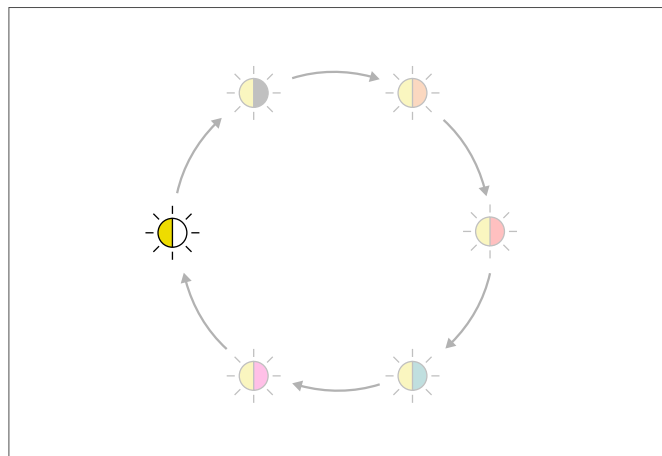



6. Hold down the LED button for 3 seconds to save the selected function.

# DRIVE – Assembly instructions

Electromechanical multi-point lock GENIUS 2.2, AS 2xxx EA / EB / CA / CB

## 5.4.4 Adjustment of the relay function (for versions EB and CB)

The function is only available in versions EB or CB.

Menu level 1	Menu level 2	value
		<b>Feedback contact = locking bolt (default setting)</b>
		Feedback contact = opener

### Prerequisites

- The status LED lights up green.
- The LED button lights up white in day mode or blue in night mode.

1. Press the LED button if no LEDs light up.
2. To change to menu level 1, press and hold down the LED button for 8 seconds until it light up magenta and emits an acoustic signal.

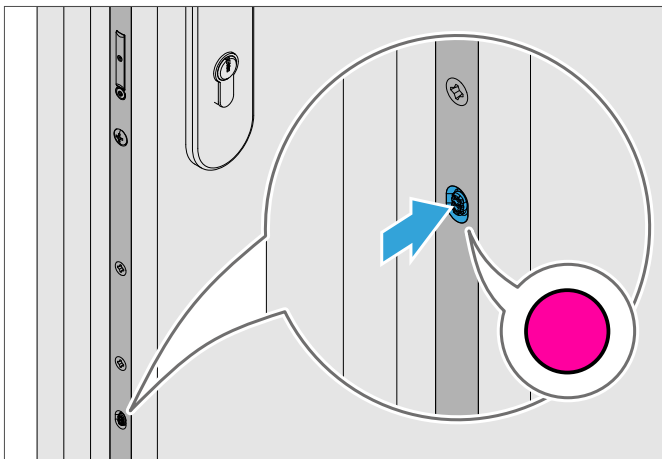

3. To adjust the relay function, press the LED button 2x until it lights up lilac.

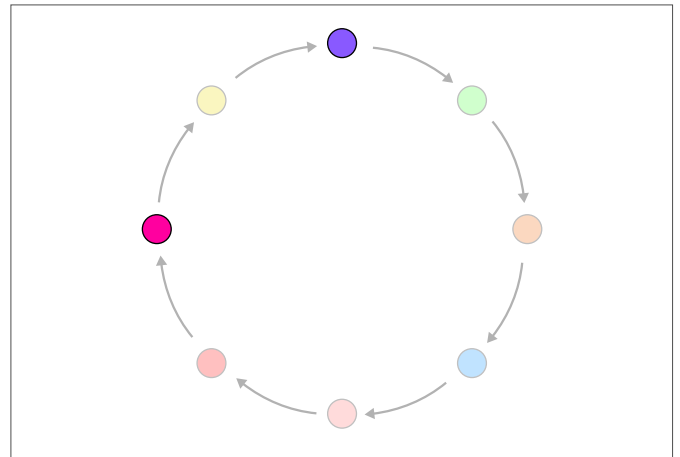

4. To change to menu level 2, press and hold down the LED button for 3 seconds.  
→ In the menu level 2 the adjusted value flashes first.
5. To select the desired function, press the LED button according to the scheme.

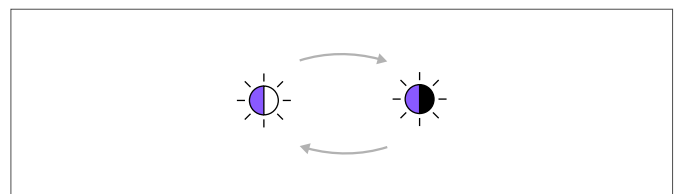

6. Hold down the LED button for 3 seconds to save the selected function.

5.4.5 Change the cylinder operated lock of the main lock

Menu level 1	Menu level 2	value
●	☀	Cylinder operated lock of the latch is active (default setting)
	☀	Cylinder operated lock of the latch is inactive

**Prerequisites**

- The status LED lights up green.
- The LED button lights up white in day mode or blue in night mode.

1. Press the LED button if no LEDs light up.
2. To change to menu level 1, press and hold down the LED button for 8 seconds until it light up magenta and emits an acoustic signal.

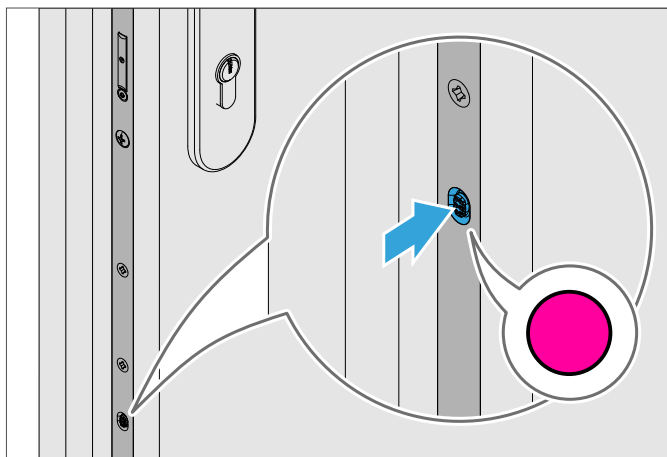

3. Press the LED button until it lights up orange to change the cylinder operated lock.
4. Press the LED button 2x for versions EA or CA.

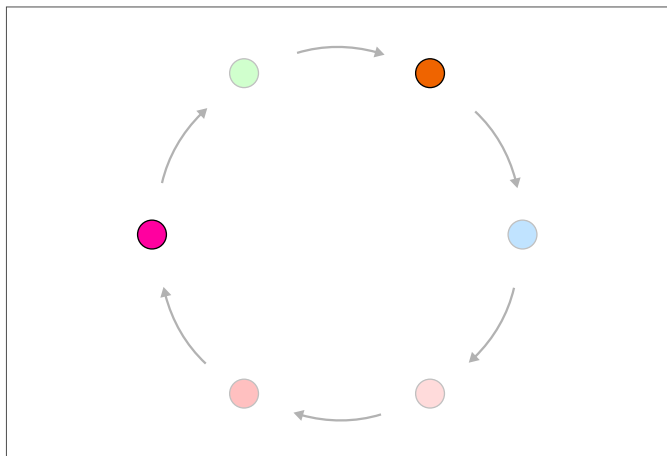

5. Press the LED button 4x for versions EB or CB.

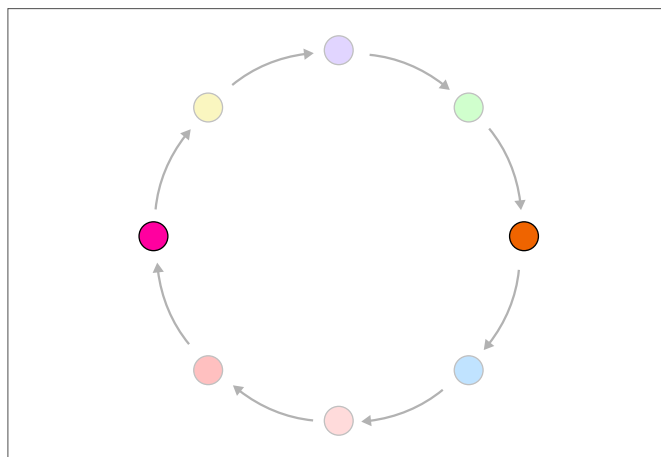

6. To change to menu level 2, press and hold down the LED button for 3 seconds.  
→ In the menu level 2 the adjusted value flashes first.
7. To select the desired function, press the LED button according to the scheme.

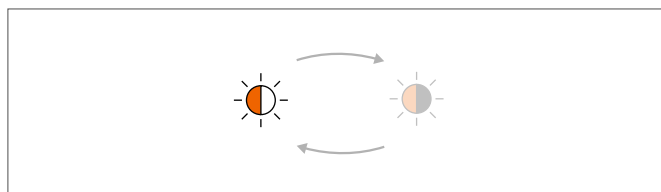

8. Hold down the LED button for 3 seconds to save the selected function.

# DRIVE – Assembly instructions

Electromechanical multi-point lock GENIUS 2.2, AS 2xxx EA / EB / CA / CB

## 5.4.6 Couple SI-BUS devices

Menu level 1	Menu level 2	value
●		Couple devices
		Separate devices
		Unlock ACS (can only be used with coupled SI-BUS and WIFI-capable device)
		Default settings
		WIFI on (Only useable with coupled SI-BUS and WIFI-capable device)
		WIFI off (Only useable with coupled SI-BUS and WIFI-capable device)

The "System services" menu can be retrieved up to 30 minutes following the system start. When the time has expired, disconnect the device from the supply voltage and reconnect.

The following digital SI-BUS devices can be coupled:

- SIEGENIA access control system
- IO module/IO module smart
- KNX Gateway

### Prerequisites

- A SI-BUS device is connected to the drive. Coupling is not necessary for the use of analogue access control systems from third-party providers.
- The status LED lights up green.
- The LED button lights up white in day mode or blue in night mode.

1. Press the LED button if no LEDs light up.

2. To change to menu level 1, press and hold down the LED button for 8 seconds until it light up magenta and emits an acoustic signal.

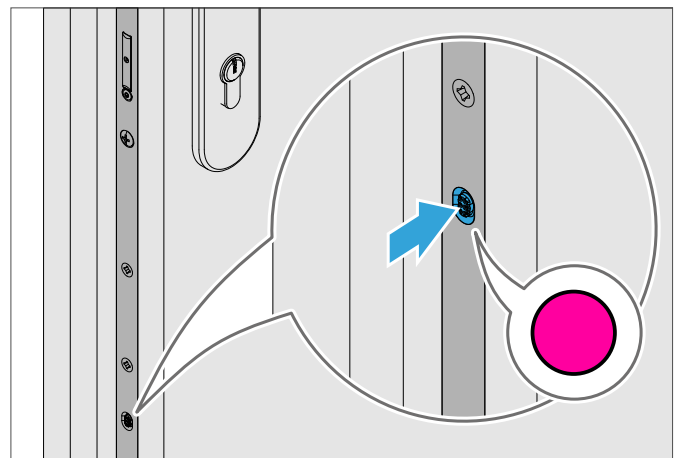

3. Press the LED button until it lights up light red to enter the "System services" menu.

4. Press the LED button 4x for versions EA or CA.

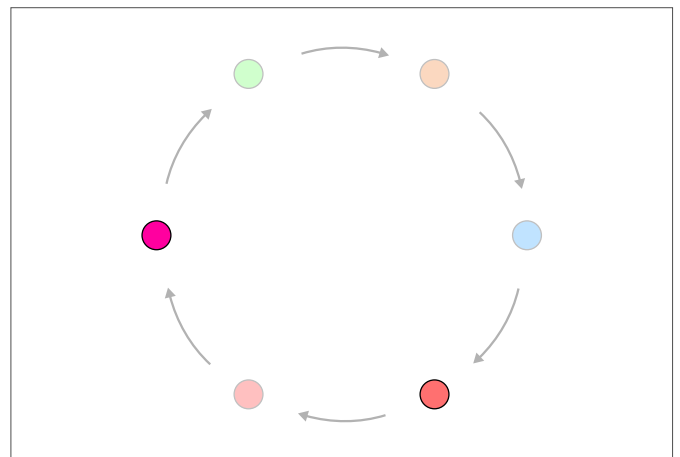

5. Press the LED button 6x for versions EB or CB.

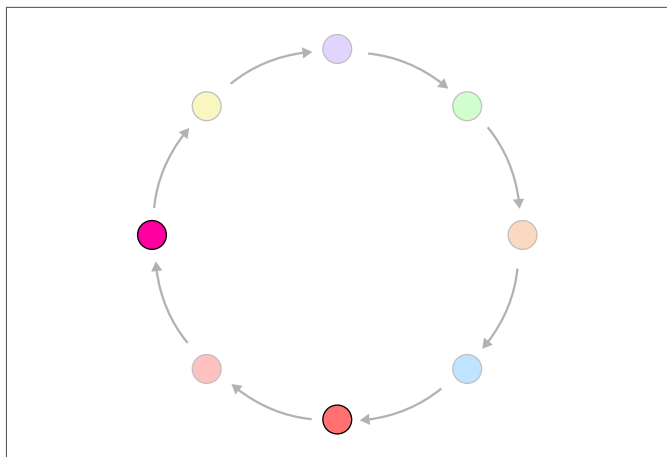

→ The LED button flashes alternatively in light red and white.

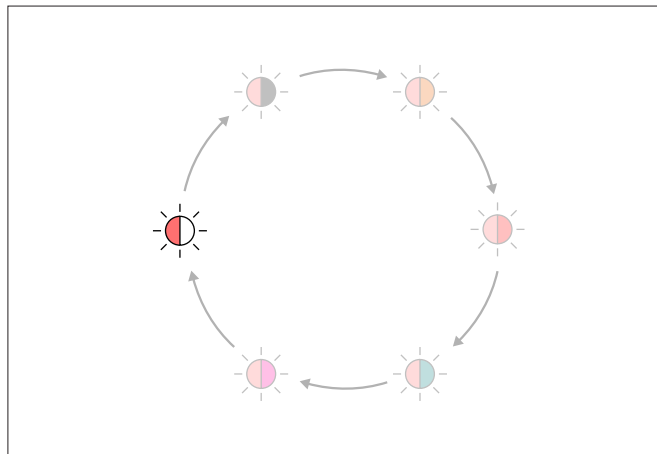

6. To change to menu level 2, press and hold down the LED button for 3 seconds.

7. Hold down LED button for 3 seconds.

→ The electromechanical multi-point lock couples itself with a connected SI-BUS device.

**5.4.7 Establishing the WIFI connection**

Menu level 1	Menu level 2	value
●		WLAN Reset (Only useable with coupled SI-BUS and WIFI-capable device)
		WPS mode (Only useable with coupled SI-BUS and WIFI-capable device)
		Info mode (Only useable with coupled SI-BUS and WIFI-capable device)

The "System services" menu can be retrieved up to 30 minutes following the system start. When the time has expired, disconnect the device from the supply voltage and reconnect.

2. To change to menu level 1, press and hold down the LED button for 8 seconds until it light up magenta and emits an acoustic signal.

**Prerequisites**

- The electromechanical multi-point lock is coupled with a WIFI-capable device. You can find information on coupling in chapter Coupling SI-BUS devices (see page 56).
- The status LED lights up green.
- The LED button lights up white in day mode or blue in night mode.

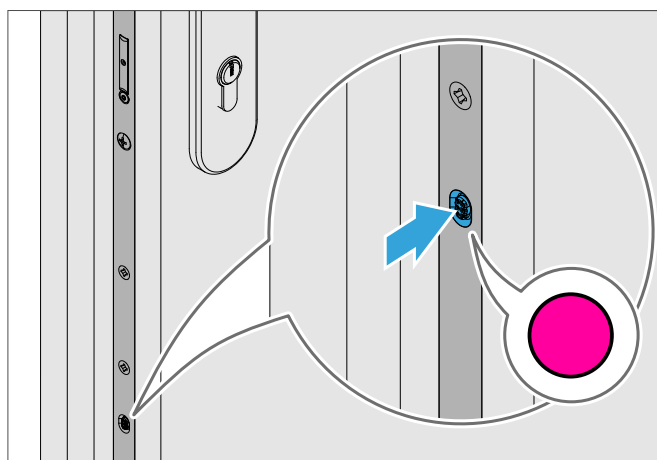

1. Press the LED button if no LEDs light up.

3. Press the LED button until it lights up red to enter the "WIFI" menu.

## DRIVE – Assembly instructions

Electromechanical multi-point lock GENIUS 2.2, AS 2xxx EA / EB / CA / CB

4. Press the LED button 5x for versions EA or CA.

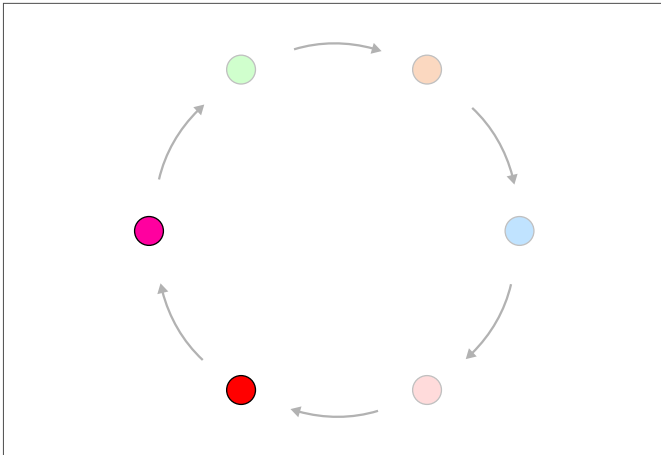

5. Press the LED button 7x for versions EB or CB.

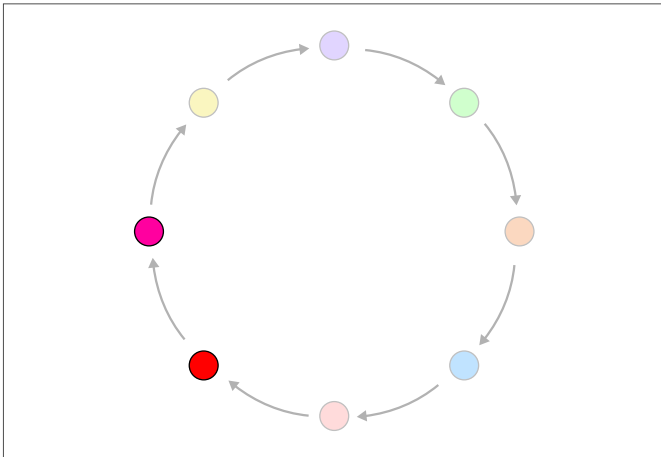

6. To change to menu level 2, press and hold down the LED button for 3 seconds.

→ The LED button flashes alternatively in red and white.

7. Press the button 1x until the LED button flashes red and black.

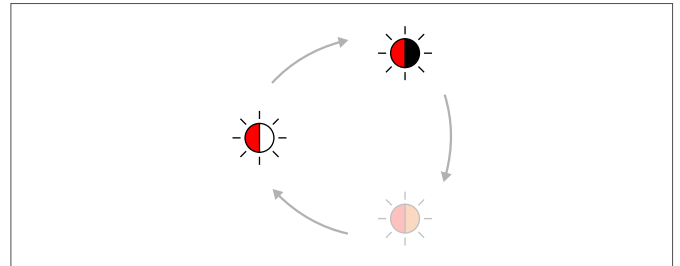

8.

9. Hold down LED button for 3 seconds.

→ The prerequisite is created to connect the electromechanical multi-point lock to the home network.

10. Download the SIEGENIA Comfort app.

### 5.5 Install the SIEGENIA Comfort app

1. Install the SIEGENIA Comfort app.



App store



Google Play Store





## 6 Troubleshooting

Problem	Possible cause	Solution
The lever handle does not return to its original position.	The handle set is not correctly positioned.	<ol style="list-style-type: none"> <li>Loosen the screwing of the handle set.</li> <li>Fix the handle set according to the producer's instructions.</li> </ol>
	The handle spindle is not accurately positioned.	<ol style="list-style-type: none"> <li>Check the milling and drilling dimensions (see page 24).</li> <li>If necessary, rework the routed pockets and holes.</li> </ol>
	The product is defective.	<ul style="list-style-type: none"> <li>Replace the product.</li> </ul>
The key cannot be pulled out.	The cylinder lock is defective.	<ul style="list-style-type: none"> <li>Contact the producer of the cylinder lock.</li> </ul>
The door locks or releases sluggishly.	The latch and the deadbolt do not run smoothly into the striker plate or into the locking rail.	<ol style="list-style-type: none"> <li>Adjust the frame parts (see page 41).</li> <li>Carry out the functional test (see page 46).</li> </ol>
	The hook bolt and bolt of the auxiliary box do not run smoothly into the striker plate or into the locking rail.	<ol style="list-style-type: none"> <li>Adjust the frame parts (see page 41).</li> <li>Carry out the functional test (see page 46).</li> </ol>
	If the routed pockets do not comply with the specified dimensions.	<ol style="list-style-type: none"> <li>Check the milling dimensions (see page 24).</li> <li>If necessary, rework the routed pockets.</li> </ol>
	The product is defective.	<ul style="list-style-type: none"> <li>Replace the product.</li> </ul>
The door does not lock automatically.	The multi-point lock is in day mode.	<ul style="list-style-type: none"> <li>Adjustment of night mode (see page 11).</li> </ul>
	The supply voltage of the multi-point lock is interrupted.	<ul style="list-style-type: none"> <li>Check the supply voltage.</li> </ul>
	The magnetic sensor is defective.	<ul style="list-style-type: none"> <li>Replace the drive (see page 60).</li> </ul>
	The position of the drive is not calibrated.	<ol style="list-style-type: none"> <li>Carry out the reference run (see page 64).</li> <li>Carry out the functional test (see page 46).</li> </ol>
	The drive is defective.	<ul style="list-style-type: none"> <li>Replace the drive (see page 60).</li> </ul>
The door does not unlock automatically.	The multi-point lock is defective.	<ul style="list-style-type: none"> <li>Replace the multi-point lock.</li> </ul>
	The supply voltage of the multi-point lock is interrupted.	<ul style="list-style-type: none"> <li>Check the supply voltage.</li> </ul>
	The magnetic sensor is not working.	<ol style="list-style-type: none"> <li>Hold a magnet to the magnetic sensor.</li> <li>Adjustment of residual airgap (see page 41).</li> <li>Check position of magnet. If necessary: adapt the position of the magnet (see page 27) according to specification.</li> <li>Teach in the magnetic sensor once again (see page 63).</li> <li>Carry out the functional test (see page 46).</li> </ol>
	The position of the drive is not calibrated.	<ol style="list-style-type: none"> <li>Carry out the reference run (see page 64).</li> <li>Carry out the functional test (see page 46).</li> </ol>
	With connected SIEGENIA access control system: the pulse control is deactivated in the SIEGENIA app.	<ul style="list-style-type: none"> <li>Activate the pulse control in the app.</li> </ul>
	With connected SIEGENIA access control system: the pulse duration in the app is set too long ( $t > 1s$ ).	<ul style="list-style-type: none"> <li>Adjust the pulse duration to <math>t = 1s</math> in the app.</li> </ul>
	The drive is defective.	<ul style="list-style-type: none"> <li>Replace the drive (see page 60).</li> </ul>
An audible signal is emitted in case of automatic locking.	The multi-point lock is defective.	<ul style="list-style-type: none"> <li>Replace the multi-point lock.</li> </ul>
	The wrong cylinder lock is installed.	<ul style="list-style-type: none"> <li>Install a FZG cylinder lock.</li> </ul>
	The cylinder lock is defective.	<ul style="list-style-type: none"> <li>Contact the producer of the cylinder lock.</li> </ul>
	The magnetic sensor is not working.	<ol style="list-style-type: none"> <li>Open the door and hold a magnet to the magnetic sensor.</li> <li>Check whether it moves to the locking position.</li> <li>Adjustment of residual airgap (see page 41).</li> <li>Check position of magnet. If necessary: adapt the position of the magnet (see page 27) according to specification.</li> <li>Teach in the magnetic sensor once again (see page 63).</li> <li>Carry out the functional test (see page 46).</li> </ol>
	The supply voltage or the operating voltage is defective.	<ol style="list-style-type: none"> <li>Check the ambient temperature.</li> <li>Check the supply voltage.</li> </ol>
	The locking elements do not extend.	<ol style="list-style-type: none"> <li>Too many consumers are connected to the supply voltage. Check the technical specifications.</li> <li>Check all milling and drilling dimensions (see page 24). If necessary, rework the milling and holes.</li> <li>Check the door hinges. If necessary, adjust the door hinges.</li> <li>Carry out the commissioning (see page 41) again.</li> </ol>
An audible signal is emitted in case of automatic release.	The wrong cylinder lock is installed.	<ul style="list-style-type: none"> <li>Install a FZG cylinder lock.</li> </ul>
	The cylinder lock is defective.	<ul style="list-style-type: none"> <li>Contact the producer of the cylinder lock.</li> </ul>
	The locking elements do not retract.	<ol style="list-style-type: none"> <li>Release and open the door manually.</li> <li>Check all milling and drilling dimensions (see page 24). If necessary: rework the milling and holes.</li> <li>Check the door hinges. If necessary, adjust the door hinges.</li> <li>Carry out the commissioning (see page 41) again.</li> </ol>
●	The supply voltage is defective.	<ul style="list-style-type: none"> <li>Check the supply voltage.</li> </ul>
	The operating voltage is exceeded.	<ul style="list-style-type: none"> <li>Check the ambient temperature (see page 32).</li> </ul>
	There is an error in the control unit.	<ul style="list-style-type: none"> <li>Contact your service partner.</li> </ul>

# DRIVE – Assembly instructions

Electromechanical multi-point lock GENIUS 2.2, AS 2xxx EA / EB / CA / CB

Problem	Possible cause	Solution
	The multi-point lock does not work.	<ul style="list-style-type: none"><li>Contact your service partner.</li></ul>
	The connecting clamp is not correctly plugged into the drive bushing.	<ul style="list-style-type: none"><li>Check the plug connection.</li></ul>
	The magnetic sensor is not working.	<ol style="list-style-type: none"><li>Hold a magnet to the magnetic sensor.</li><li>Check whether the drive moves to the locking position.</li><li>Adjustment of residual airgap (see page 41).</li><li>Check position of magnet. If necessary: adapt the position of the magnet (see page 27) according to specification.</li><li>Teach in the magnetic sensor once again (see page 63).</li></ol>
	The locking elements are extended when the door is open.	<ul style="list-style-type: none"><li>Retract the locking elements prior to closing the door.</li></ul>

## 6.1 Replacement of drive

Replace the entire multi-point lock for fire-rated doors. Do not just replace the drive.

- Lock the multi-point lock using the key with the door open.  
→ The locking elements are extended.
- Dismount the handle set and the cylinder lock.
- Loosen all the fixing screws from the multi-point lock.
- Remove the multi-point lock from the door leaf. Ensure that the cable connection is not damaged.
- Remove the PTR plug.

- Loosen the fixing screws of the drive. Remove the defective drive from the drive rod and dispose of the screws.

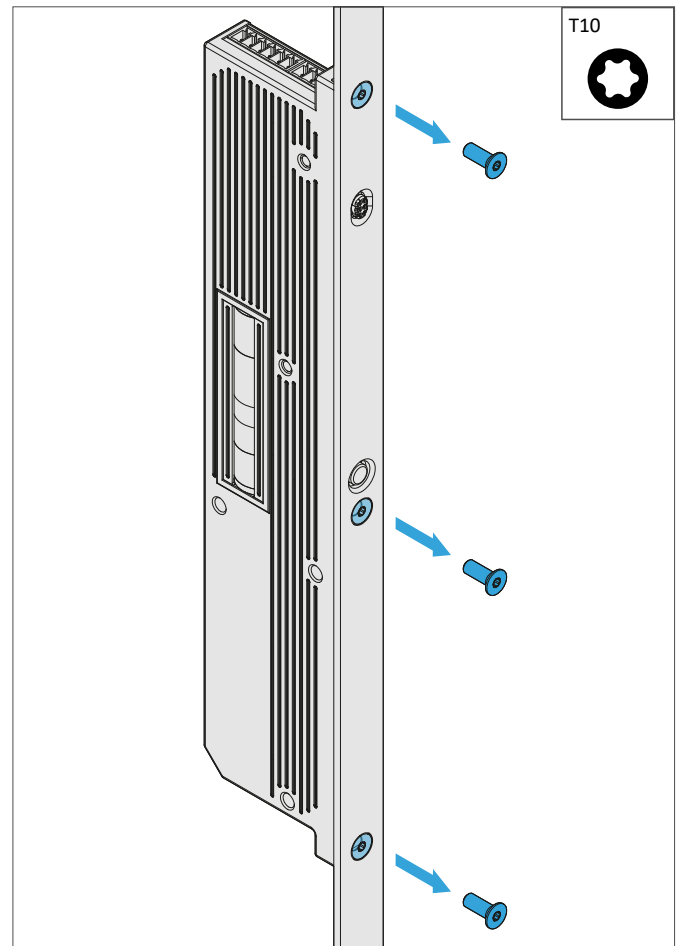

7. Move the slider of the new drive for the position inquiry and for the drive rod into the bottom end position.

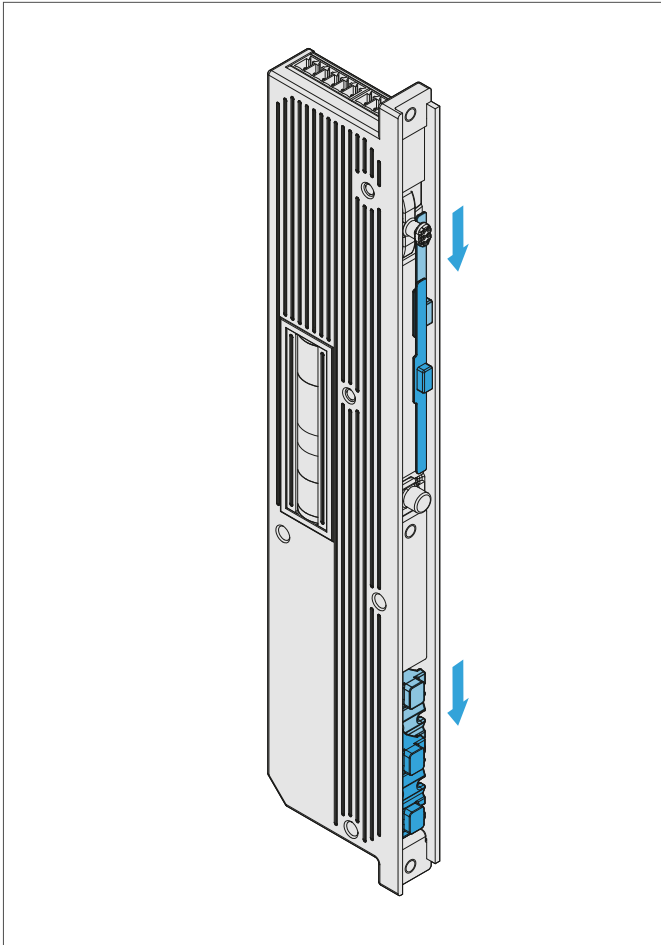

8. Suspend the drive in the drive rod.

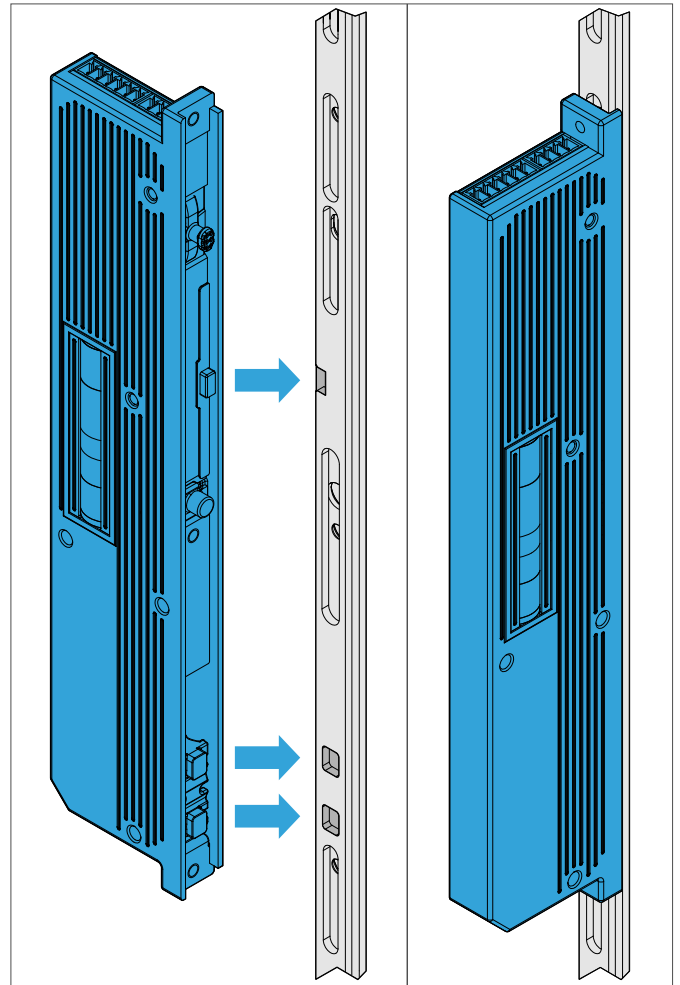

## DRIVE – Assembly instructions

Electromechanical multi-point lock GENIUS 2.2, AS 2xxx EA / EB / CA / CB

---

9. Screw the drive with the secondary sash into place with a torque of 1.3 Nm.

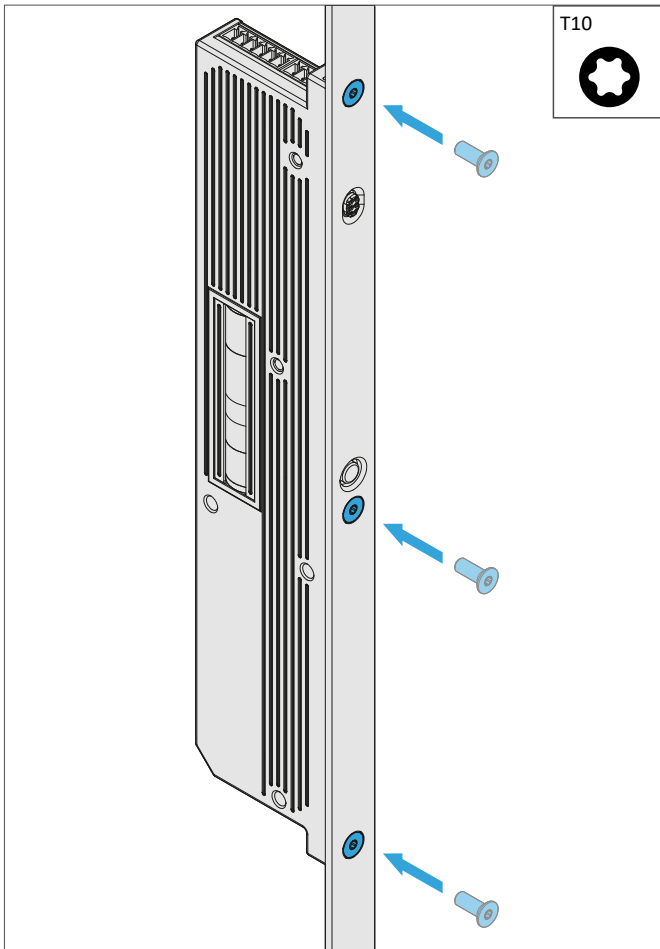

10. Connect the PTR plug.

11. Insert the multi-point lock and screw into place (see page 36).

12. Carry out the reference run (see page 64).

13. Carry out the functional test (see page 46).



# DRIVE – Assembly instructions

Electromechanical multi-point lock GENIUS 2.2, AS 2xxx EA / EB / CA / CB

## 6.3 Start reference run

Menu level 1	Menu level 2	value
●	☀	Restart the device
	●	Default setting
	☀	Software version
	☀	Teach in magnetic sensor
	☀	Reference run

### Prerequisites

- The status LED lights up green.
- The LED button lights up white in day mode or blue in night mode.

1. Press the LED button if no LEDs light up.
2. To change to menu level 1, press and hold down the LED button for 8 seconds until it light up magenta and emits an acoustic signal.

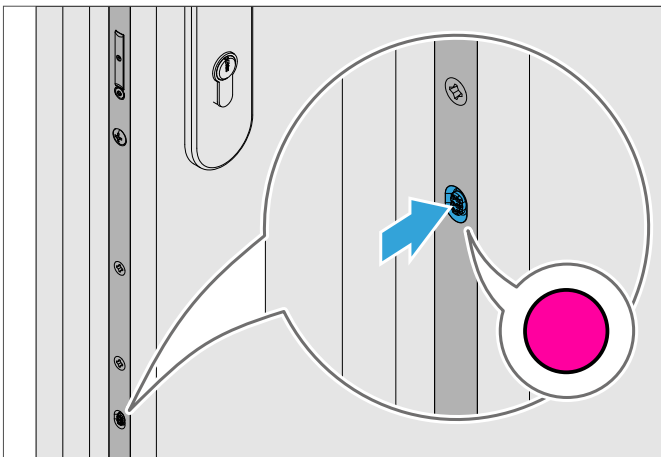

3. Press the LED button until it lights up light blue to proceed to the "Device services" menu.
4. Press the LED button 3x for versions EA or CA.

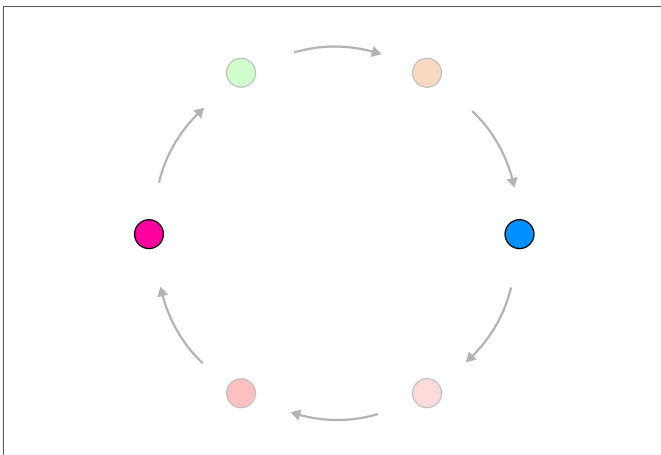

5. Press the LED button 5x for versions EB or CB.

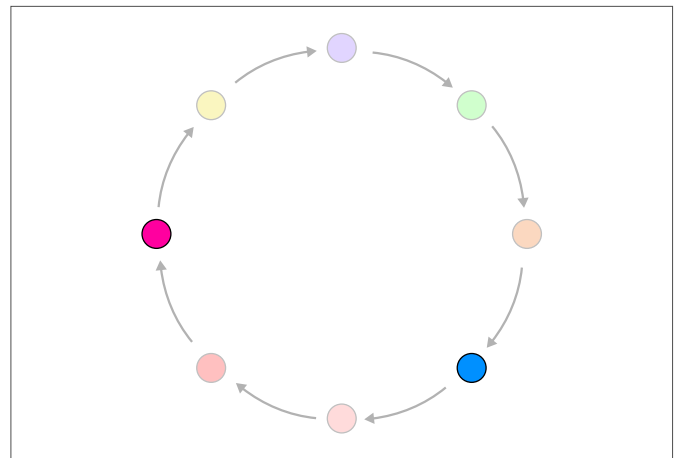

6. To change to menu level 2, press and hold down the LED button for 3 seconds.
7. To start the reference run, press the LED button 4x until it flashed light blue and turquoise.

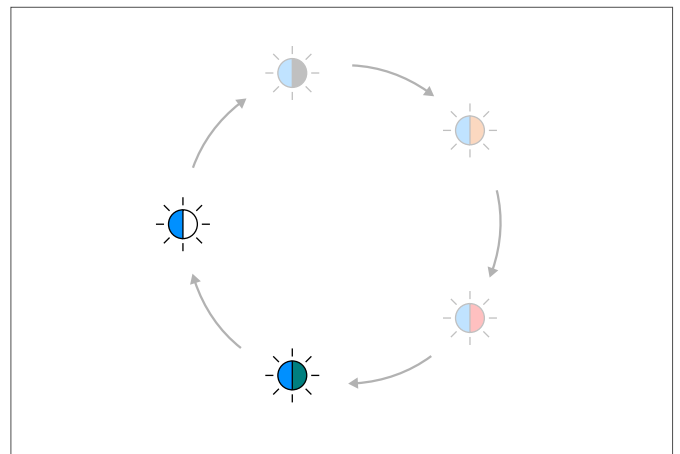

8. Hold down LED button for 3 seconds.

→ The reference run starts. The drive of the electromechanical multi-point lock moves to the end position.

**7 Certificates**

**7.1 EU Declaration of incorporation**

We, the producer, hereby declare that our product complies with the following directives.

Producer	Product	
KFV Karl Fliether GmbH & Co. KG Siemensstraße 10 42551 Velbert	Device type:	Type designation:
	electromechanical drive for multi-point locks	GENIUS 2.2 A / B / PANIC

GUIDELINE	Harmonised standards	
Machinery Directive	2006/42/EC	EN ISO 12100:2010

The incomplete machine may only be commissioned if it has been ascertained that the machine into which it is to be installed conforms to the specifications of the Machinery Directive. The specific technical documentation has been compiled in accordance with Appendix VII Part B of the EC Machinery Directive 2006/42/EC. We undertake to provide such documentation to the regulatory authorities in electronic format within a reasonable time upon a well-founded request. The aforementioned technical documentation can be obtained from the producer.



---

Velbert, 2019-08-28 Uwe Ziewers  
(Site Manager)

[www.siegenia.com](http://www.siegenia.com)



**SIEGENIA®**  
brings spaces to life