

SPW600e

SPW600e Casement

**Product Assembly
Manual 2012
Outward Opening
Casement**

Scope

This specification covers the materials, sections and accessories generally available from stock through the Senior Architectural Systems group of companies. It illustrates typical recommendations for the fabrication of our SPW600e Casement Window. The sections and fittings described in this manual are not definitive or exclusive in application but show typical assemblies using standard materials and accessories.

Identical main line extrusions are used for both single and dual colour finishes.

These details are suitable for installations in both new buildings and re-furbishments, which should comply with the latest building regulations.

Construction

SPW600e Casement Windows are constructed using mitred and mechanically crimped corners, with support chevrons and cleats. Integral transoms and mullions are installed by scribing the ends and then either screw fixing or bracket fixing into the outer frames.

A proprietary sealant to protect against water entry should be used on all metal-to-metal joints and cleat insertion points at assembly.

Opening window frames are designed to be inserted directly into the outer frames using butt hinges or friction stays.

Thermal

The window system has been designed to meet the current Building Regulations. The thermal performance of the frame (Uf) can be further improved with the use of polystyrene inserts.

Window Energy Ratings are also possible to meet building regulation part L1B (domestic replacement) from accredited fabricators/installers.

Separate figures are available for Thermal U-values depending on type of frame and glazing material.

Accessories

All accessories shown in this manual are deemed to be both typical, and suitable for, the installations intended. They are generally standard items, which carry with them the manufacturers guarantees and are components that are held in stock.

Testing

The SPW600e Casement Windows are tested in accordance with BS6375 Part 1, 1989, BS7950 :1997, Equipment as required in BS5368: Part 1: 1976.

Test Results Available On Request.

Materials

Extruded aluminium is Aluminium Alloy 6063.T6 to BS EN 755 part 9 : 2008.

Polyamide thermal barriers PA66 GF25

Anodising: i) Natural (Silver) anodised to BS3987, 1991. and ii) Anolok Bronze Colour 547 anodised to BS3987, 1991. Anodising is to a minimum of 25 microns (AA25).

Powder Coating is to BS EN 12206-1:2004.

Gasketry is manufactured in accordance with BS3734.

Glazing

Note: All Glazing should be carried out to the recommendations of BS.6262.

Double glazing to 28mm and 32mm may be installed into this window system.

Each pane of glass is individually inserted into a fully rebated and prepared opening.

Glass is retained in position with beads which for outside glazing carry the captive gasket, wedge gaskets are to the inside of the glass to assist with security.

Inside beaded sections form part of the system.

Site Installation

Site fixing of finished frames should take into account all applicable standards with regard to both the method employed and safe working practices.

Frame fixings should be suitable for the purpose given site conditions and materials into which the installation is to be made. If in doubt, please check with your fixings supplier regarding type and method to be used.

Security

The SPW600 Series Casement has been designed to meet the requirements of Secure By Design (SBD). The casement has been tested to BS7950.

Fabricators are required to obtain third party accreditation under SBD such as the Q-Mark. Please contact your local Technical Sales Representative for further information.

Size Limitations

Size limitations for each type of window vary. The following schedule is an indication of the SPW600 system capabilities.

	W	x	H
Top Hung O/Out	1500	x	1500
Side Hung O/Out	900	x	1500

Multi-lights: *all mullions and transoms over 1200mm high or wide should be checked for lxx value stability to loadings provided by the specifier, or to BS6399 part 2:1997*

The above schedule is based on nominal test results and assumes that adequate care regarding the location and exposure of the window is taken by the fabricator.

Due regard should be given to the maximum recommended Sizes, as published by the friction stay manufacturers.

Index

<i>Description</i>	<i>Detail</i>	<i>Page.</i>	<i>Last Issue Date</i>
Front Cover		SPW600e.1.i	04.12
Introduction		SPW600e.1.ii	04.12
Specification		SPW600e.1.iii	04.12
Index		SPW600e.1.iv	09.14
Index		SPW600e.1.v	09.14
Index		SPW600e.1.vi	10.13
Blank		SPW600e.1.vii	04.12
"B" Rated Window Specification		SPW600e.1.viii	04.12
"C" Rated Window Specification		SPW600e.1.ix	04.12
Section Identification		SPW600e.1.x	04.12
Section Identification		SPW600e.1.xi	04.12

Manual Update

SPW600e.1.MU.i	09.14
SPW600e.1.MU.ii	09.13

A - General Arrangements

General Arrangements	Vertical C.S.- Outward Opening Ext. Glazed	SPW600e.A.101	04.12
General Arrangements	Vertical C.S.- Outward Opening Ext. Glazed	SPW600e.A.102	04.12
General Arrangements	Vertical C.S.- Outward Opening Int. Glazed	SPW600e.A.103	04.12
General Arrangements	Vertical C.S.- Outward Opening Int. Glazed	SPW600e.A.104	04.12
General Arrangements	Vertical C.S.- Outward Opening Int. Glazed	SPW600e.A.105	04.12
General Arrangements	Vertical C.S.- Outward Opening Int. Glazed	SPW600e.A.106	04.12
General Arrangements	Vertical C.S.- Outward Opening Int. Glazed	SPW600e.A.107	04.12
General Arrangements	Vertical C.S.- Outward Opening Int. Glazed	SPW600e.A.108	04.12
General Arrangements	Vertical C.S.- Outward Opening Int. Glazed	SPW600e.A.109	04.12
General Arrangements	Vertical C.S.- Outward Opening Int. Glazed	SPW600e.A.110	04.12
General Arrangements	Vertical C.S.- Outward Opening Int. Glazed	SPW600e.A.111	04.12
General Arrangements	Vertical C.S.- Outward Opening Int. Glazed	SPW600e.A.112	04.12
General Arrangements	Vertical C.S.- Outward Opening Int. Glazed	SPW600e.A.113	04.12
General Arrangements	Vertical C.S.- Outward Opening Int. Glazed	SPW600e.A.114	04.12
General Arrangements	Vertical C.S.- 28mm C/Wall Outer	SPW600e.A.115	04.12
General Arrangements	Vertical C.S.- 28mm C/Wall Outer	SPW600e.A.116	04.12
General Arrangements	Vertical C.S.- 28mm C/Wall Outer	SPW600e.A.117	04.12
Blank	Blank	SPW600e.A.118	04.12
General Arrangements	Vertical C.S.- Outward Opening Int. Glazed	SPW600e.A.119	04.12
General Arrangements	Vertical C.S.- Outward Open Int. Glazed Sash	SPW600e.A.120	04.12
General Arrangements	Vertical C.S.- Outward Opening Int. Glazed	SPW600e.A.121	04.12
General Arrangements	Vertical C.S.- 28mm C/Wall Outer	SPW600e.A.122	04.12

B - Section Identification

Section Identification	Section Identification	SPW600e.B.101	04.12
Section Identification	Section Identification	SPW600e.B.102	04.12
Section Identification	Section Identification	SPW600e.B.103	04.12
Section Identification	Section Identification	SPW600e.B.104	04.12
Section Identification	Section Identification	SPW600e.B.105	04.12
Section Identification	Section Identification	SPW600e.B.106	04.12
Section Identification	Section Identification	SPW600e.B.107	04.12
Section Identification	Section Identification	SPW600e.B.108	04.12
Section Identification	Section Identification	SPW600e.B.109	04.12
Section Identification	Section Identification	SPW600e.B.110	04.12
Section Identification	Section Identification	SPW600e.B.111	04.12
Section Identification	Section Identification	SPW600e.B.112	04.12
Section Identification	Section Identification 70mm Kingspan Adapter	SPW600e.B.113	04.12
Section Identification	Section Identification 80mm Kingspan Adapter	SPW600e.B.114	04.12
Section Identification	Section Identification 100mm Kingspan Adapter	SPW600e.B.115	04.12
Blank	Blank	SPW600e.B.116	04.12

SPW600e Casement

SPW600e.1.v

09.14

Index

<i>Description</i>	<i>Detail</i>	<i>Page</i>	<i>Last Issue Date</i>
C- Accessories			
<i>Accessories</i>	<i>Accessories</i>	SPW600e.C.101	04.12
<i>Accessories</i>	<i>Accessories</i>	SPW600e.C.102	06.13
<i>Accessories</i>	<i>Accessories</i>	SPW600e.C.103	10.13
<i>Accessories</i>	<i>Accessories - Gaskets & Seals</i>	SPW600e.C.104	09.14
D - Cutting Formulas, Glass Deductions & Fabrication			
<i>Deductions</i>	<i>Frame & Glass</i>	SPW600e.D.101	04.12
<i>Deductions</i>	<i>Frame & Glass</i>	SPW600e.D.102	04.12
<i>Deductions</i>	<i>Frame & Glass</i>	SPW600e.D.103	04.12
<i>Deductions</i>	<i>Frame & Glass</i>	SPW600e.D.104	04.12
<i>Deductions</i>	<i>Frame & Glass</i>	SPW600e.D.105	04.12
<i>Deductions</i>	<i>Frame & Glass</i>	SPW600e.D.106	04.12
<i>Deductions</i>	<i>Frame & Glass</i>	SPW600e.D.107	04.12
<i>Deductions</i>	<i>Frame & Glass</i>	SPW600e.D.108	04.12
<i>Cutting</i>	<i>Cutting/Clamping Profiles/Placement</i>	SPW600e.D.109	04.12
<i>Drainage</i>	<i>External Glazed</i>	SPW600e.D.110	04.12
<i>Drainage</i>	<i>Internal Glazed</i>	SPW600e.D.111	04.12
<i>Drainage</i>	<i>Internal Glazed</i>	SPW600e.D.112	04.12
<i>Drainage</i>	<i>Internal Glazed</i>	SPW600e.D.113	04.12
<i>Drainage</i>	<i>Internal Glazed</i>	SPW600e.D.114	04.12
<i>Drainage</i>	<i>28mm Drainage Bead External Glazed</i>	SPW600e.D.115	04.12
<i>Drainage</i>	<i>32mm Drainage Bead External Glazed</i>	SPW600e.D.116	04.12
<i>Drainage</i>	<i>SPW6003002 Vent Only</i>	SPW600e.D.117	04.12
<i>Blank</i>	<i>Blank</i>	SPW600e.D.118	04.12
E - Preparation & Assembly			
<i>Assembly</i>	<i>Trans/Mull (Ext Gl.) Shear Block & Screw Fix</i>	SPW600e.E.101	04.12
<i>Assembly</i>	<i>Trans/Mull (Int Gl.) Shear Block & Screw Fix</i>	SPW600e.E.102	04.12
<i>Assembly</i>	<i>Trans/Mull Shear Block & Screw Fix</i>	SPW600e.E.103	04.12
<i>Assembly</i>	<i>Corner Cleats & Thermal Inserts</i>	SPW600e.E.104	04.12
<i>Preparation</i>	<i>Defender Friction Stays T/H & S/H Applications</i>	SPW600e.E.105	04.12
<i>Preparation</i>	<i>Stays T/H & S/H Apps Use With SPW6003002</i>	SPW600e.E.106	09.13
<i>Preparation</i>	<i>17mm Heavy Duty Stays</i>	SPW600e.E.107	04.12
<i>Preparation</i>	<i>Butt Hinge - Open Out</i>	SPW600e.E.108	10.13
<i>Preparation</i>	<i>Folding Opener</i>	SPW600e.E.109	04.12
<i>Preparation</i>	<i>WMS Espagnolette Locking</i>	SPW600e.E.110	04.12
<i>Preparation</i>	<i>Handle & Wedge T/H or S/H SPW60304 Sash</i>	SPW600e.E.111	06.13
<i>Preparation</i>	<i>Handle & Wedge T/H or S/H SPW6003002</i>	SPW600e.E.112	06.13
<i>Preparation</i>	<i>Shootbolt Espag Prep - SPW68693 Sash</i>	SPW600e.E.113	04.12
<i>Preparation</i>	<i>Shootbolt Espag Prep - SPW6003002 Sash</i>	SPW600e.E.114	04.12
<i>Preparation</i>	<i>Shootbolt Espag</i>	SPW600e.E.115	04.12
<i>Blank</i>	<i>Blank</i>	SPW600e.E.116	04.12
<i>Preparation</i>	<i>Hinge Restrictors - SPW68693 Sash</i>	SPW600e.E.117	04.12
<i>Preparation</i>	<i>Hinge Restrictors - SPW6003002 Sash</i>	SPW600e.E.118	04.12
<i>Preparation</i>	<i>SWR Restrictor</i>	SPW600e.E.119	04.12
<i>Preparation</i>	<i>Foam Selection & Insertion - In Section</i>	SPW600e.E.120	04.12
<i>Preparation</i>	<i>Foam Selection & Insertion - Under Glass</i>	SPW600e.E.121	04.12
<i>Preparation</i>	<i>Blank</i>	SPW600e.E.122	04.12

Index

<i>Description</i>	<i>Detail</i>	<i>Page.</i>	<i>Last Issue Date</i>
F - Glazing			
Glazing	Glazing	SPW600e.F.101	04.12
Glazing	Glazing	SPW600e.F.102	04.12
Glazing	Georgian Bar Details	SPW600e.F.103	04.12
Glazing	Georgian Bar Details	SPW600e.F.104	04.12
Glazing	Georgian Bar Details	SPW600e.F.105	04.12
Glazing	Georgian Bar Cruciform	SPW600e.F.106	04.12
G - Installation			
Installation	Trickle Vent Detail	SPW600e.G.101	04.12
Installation	Over Glass 28mm Trickle Vent Details	SPW600e.G.102	04.12
Installation	Steel Fixing Lugs	SPW600e.G.103	04.12
Installation	25mm Add-On & Weather Bar	SPW600e.G.104	04.12
Installation	T & H Couplers	SPW600e.G.105	04.12
Installation	Coupler & Reinforced Coupler	SPW600e.G.106	04.12
Installation	SPW600 To SPW300 Coupling	SPW600e.G.107	04.12
Installation	150mm Cill & Drainage Tray	SPW600e.G.108	04.12
Installation	190mm Cill	SPW600e.G.109	04.12
Installation	Run Up Blocks & Locking Wedges	SPW600e.G.110	10.13
Installation	Locking Wedges	SPW600e.G.111	10.13
Installation	STC7357 Corner Post	SPW600e.G.112	04.12
H - Panel Systems			
Installation	Kingspan - 70mm Head/Cill Detail	SPW600e.H.101	04.12
Installation	Kingspan - 70mm Side Jamb Detail	SPW600e.H.102	04.12
Installation	Kingspan - 80mm Head/Cill Detail	SPW600e.H.103	04.12
Installation	Kingspan - 80mm Side Jamb Detail	SPW600e.H.104	04.12
Installation	Kingspan - 100mm Head/Cill Detail	SPW600e.H.105	04.12
Installation	Kingspan - 100mm Side Jamb Detail	SPW600e.H.106	04.12

This Page is Intentionally Left Blank

SPW600e "B" Rated Casement

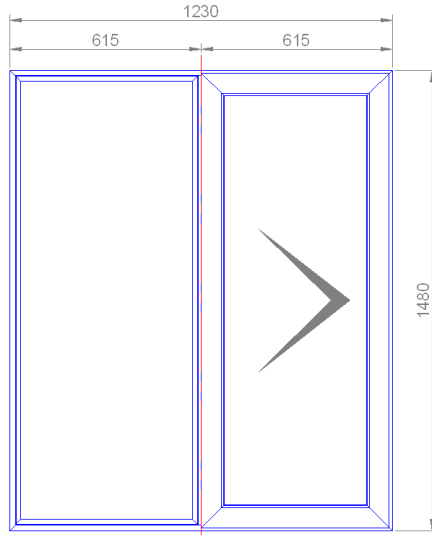
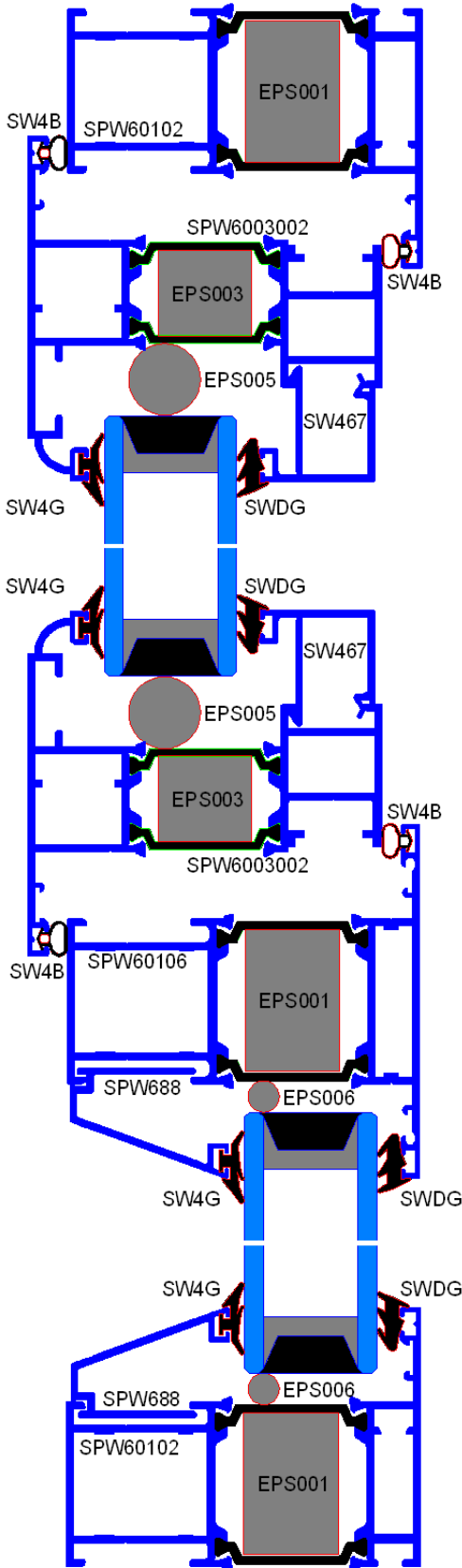

Window Energy Ratings use a consumer-friendly traffic-light style A-E ratings guide similar to that used on 'white' goods (such as fridges, freezers, washing machines etc...) where 'A' is the best rating. This ratings label can be used by you to make more informed choices about the energy efficiency of the windows you are looking to purchase. Current Building Regulation Part L1B allows replacement domestic windows to carry a 'C' rating or better.

Glass Specification:
 4 - 20 - 4
 Soft coat
 Gas fill 90% Argon
 Centre Pane U-Value = 1.2 W/(m²K)
 G - Value = 0.74
 Warm Edge Spacer
 Overall Window U-Value = 1.57 W/(m²K)

Energy Window	
Casement Window	
Energy Index (kWh/m ² /year) <small>(Energy Index certified by SFRC and based on UK standard window. The actual energy consumption for a specific application will depend on the building, the local climate and the indoor temperature)</small>	-7
The climate zone is:	UK

NOTE : To comply, manufacturers are required to obtain certification from an authorised body. Please contact Senior Architectural System Ltd. for further guidance.



OUTER FRAMES

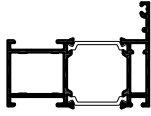

SPW60102
CASEMENT OUTER

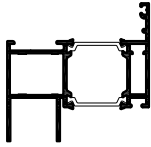

SPW66902
CURTAIN WALL CASEMENT OUTER (28mm)

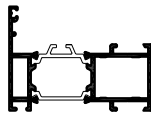

SPW61213
INT.GL OUTER

CLEATS

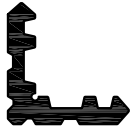

SPW645
Corner Cleat - 14.4mm

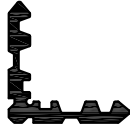

SXTW281
Corner Cleat - 11.2mm

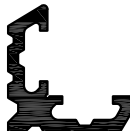

SW445
Corner Cleat - 21mm

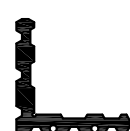

SW410
Corner Cleat - 9.4mm

VENT FRAMES

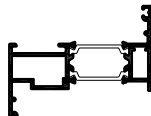

SPW60304
CASEMENT VENT

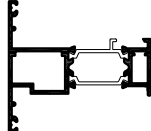

SPW60708
INT. GLAZED VENT

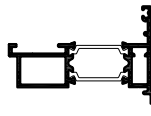

SPW63046
CASEMENT INT.GLAZE ADAPTOR

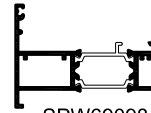

SPW69098
CASEMENT INT.GLAZE ADAPTOR
FIXED LIGHT

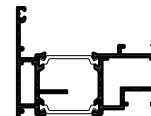

SPW68693
ESPAG VENT FRAME

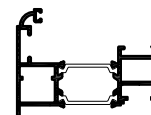

SPW6003002
ESPAG SASH

BEADS



SPW643
28mm INT.
GLAZED BEAD



SW467
28mm INT.
GLAZED BEAD



SPW621
28mm EXT.
GLAZED BEAD



SPW688
28mm EXT. GLAZED
BEAD (Use with SPW687)



SPW624
32mm INT. GLAZED BEAD



SPW696
32mm EXT. GLAZED
DRAINAGE BEAD



SPW697
32mm EXT. GLAZED BEAD



SPW687
28mm EXT. GLAZED
DRAINAGE BEAD

MULLIONS/TRANSOMS

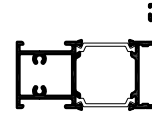

SPW60506
TRANSOM/MULLION EXT.GL.

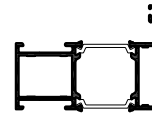

SPW60106
TRANSOM/MULLION
SHEARBLOCK EXT.GL.

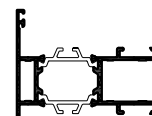

SPW61813
TRANSOM/MULLION
SHEARBLOCK INT.GL.

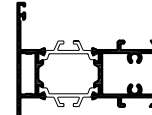

SPW61817
TRANSOM/MULLION INT. GL.

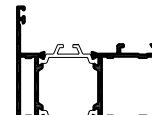

SPW61940
HEAVY DUTY
TRANSOM/MULLION INT. GL.

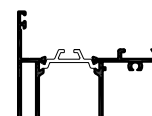

SPW65455
120mm DEEP RAIL

SPW600e Casement

Section Identification

SPW600e.1.xi

04.12

ANCILLIARIES

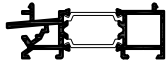

SPW68553
DRAINAGE CILL



SPW65353
25mm ADD-ON

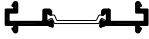

SPW65959
COUPLING SECTION

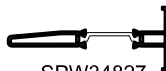

SPW34827
SPW600 To SPW300 COUPLING SECTION



SPW65994
T COUPLING SECTION



SPW69494
H COUPLING SECTION

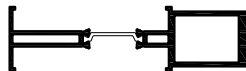

SPW629358
REINFORCED COUPLING SECTION



SAE25X4
Georgian Bar



SX204
Georgian Bar



SXTW204T
28mm Vent Carrier

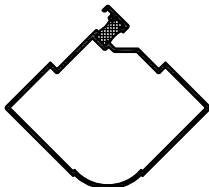

STC7357T
Corner Post

KINGSPAN ADAPTERS

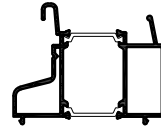

SPW67173
Kingspan
80mm Head Adaptor

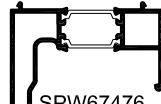

SPW67476
Kingspan
80mm Cill Adaptor

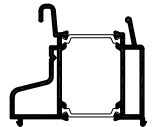

SPW67172
Kingspan
70mm Head Adaptor

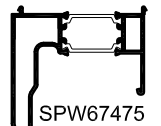

SPW67475
Kingspan
70mm Cill Adaptor

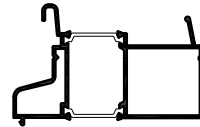

SPW671382
Kingspan
100mm Head Adaptor

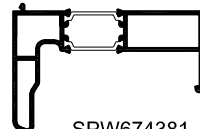

SPW674381
Kingspan
100mm Cill Adaptor

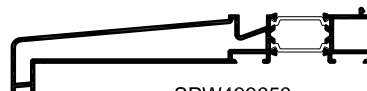

SPW499653
190mm Cill

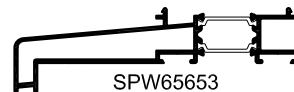

SPW65653
150mm CILL

Manual Update

Page No	Update Description	Date	By	Aprvd
SPW600e Casement	Previously SPW600 Casement	04.12		-
	Foam Inserts for sections added, SPW6003002 espag sash added,			-
	SPW64402 c/wall 24mm omitted, SXTW201 georgian bar omitted -			-
	see now SAE25X4, Polyamide PAW289100 was 216100,			-
	Cockspur handles updated to current stock			-
	Including general updates to contents.			-
SPW600e.C.102	Cockspur handle packers SW2PB/SW2PW added.	06.13		-
	SWHW5W/SWHW5B corrected to SWHW3W/SWHW3B.			-
SPW600e.E.111	Cockspur handle packers SW2PB/SW2PW added.	06.13		-
SPW600e.E.112	Cockspur handle packers SW2PB/SW2PW added.	06.13		-
SPW600e.E.106	Head section - position of datum corrected (lowered 5mm).	09.13		-
SPW600e.E.108	SPW6BUTTOOUTX image updated, 3-Holes rather than 2-holes.	10.13		-
SPW600e.C.103	SPW6BUTTOOUTX image updated, 3-Holes rather than 2-holes.	10.13		-
SPW600e.G.110	SPWSRB Run-Up Block Added.	10.13		-
SPW600e.G.111	Modified to accommodate mods to previous page	10.13		-
SPW600e.C.104	26mm Glazing Option Should Shown 30mm. Changed To Suit.	09.14	MAL	-

Manual Update

Page No	Update Description	Date

SPW600.A.101

SPW600 Casement

04.12

Vertical Cross Section - Outward Opening Ext. Glazed

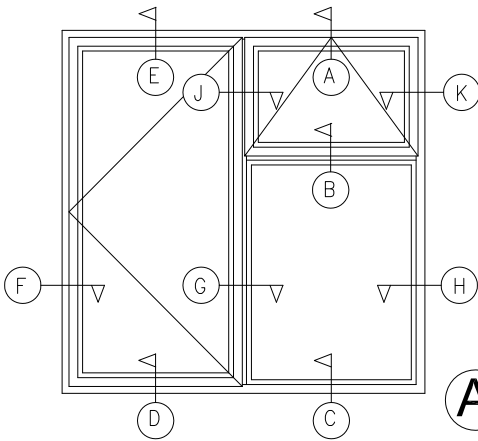

Typical Outside Elevation

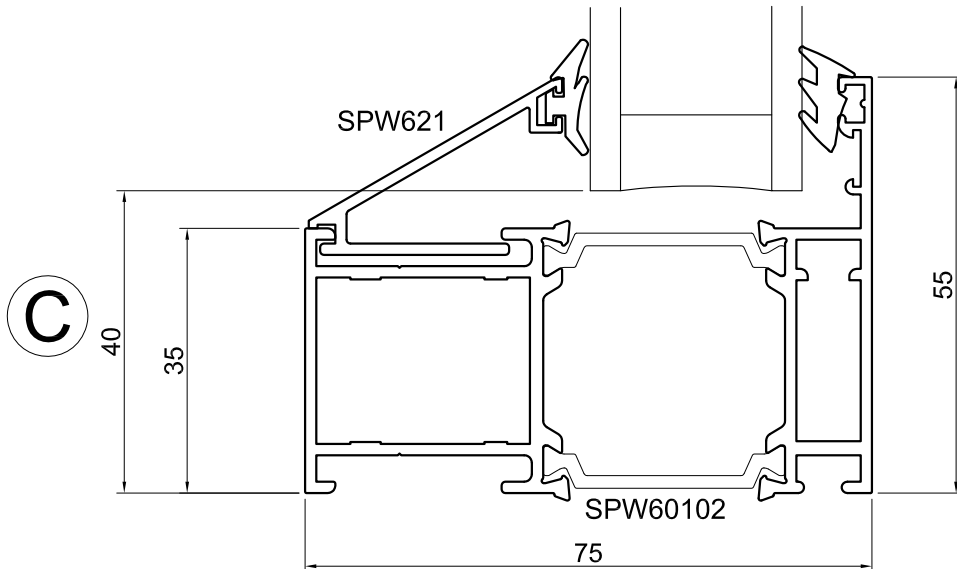
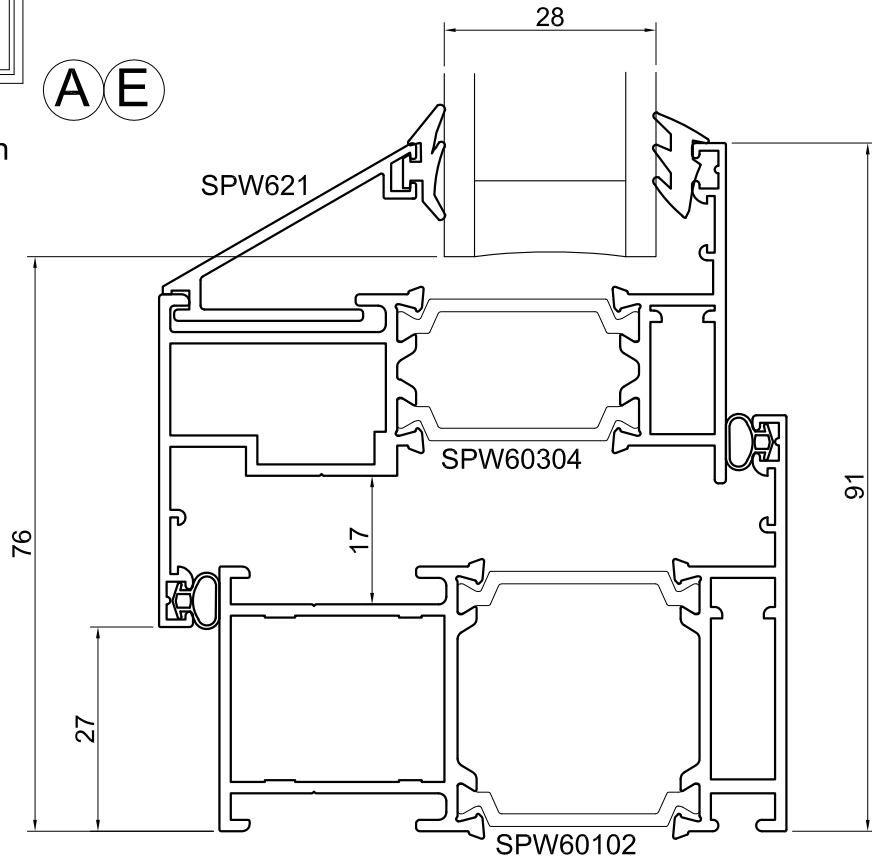

SPW600e Casement

SPW600e.A.102

Vertical Cross Section - Outward Opening External Glazed

04.12

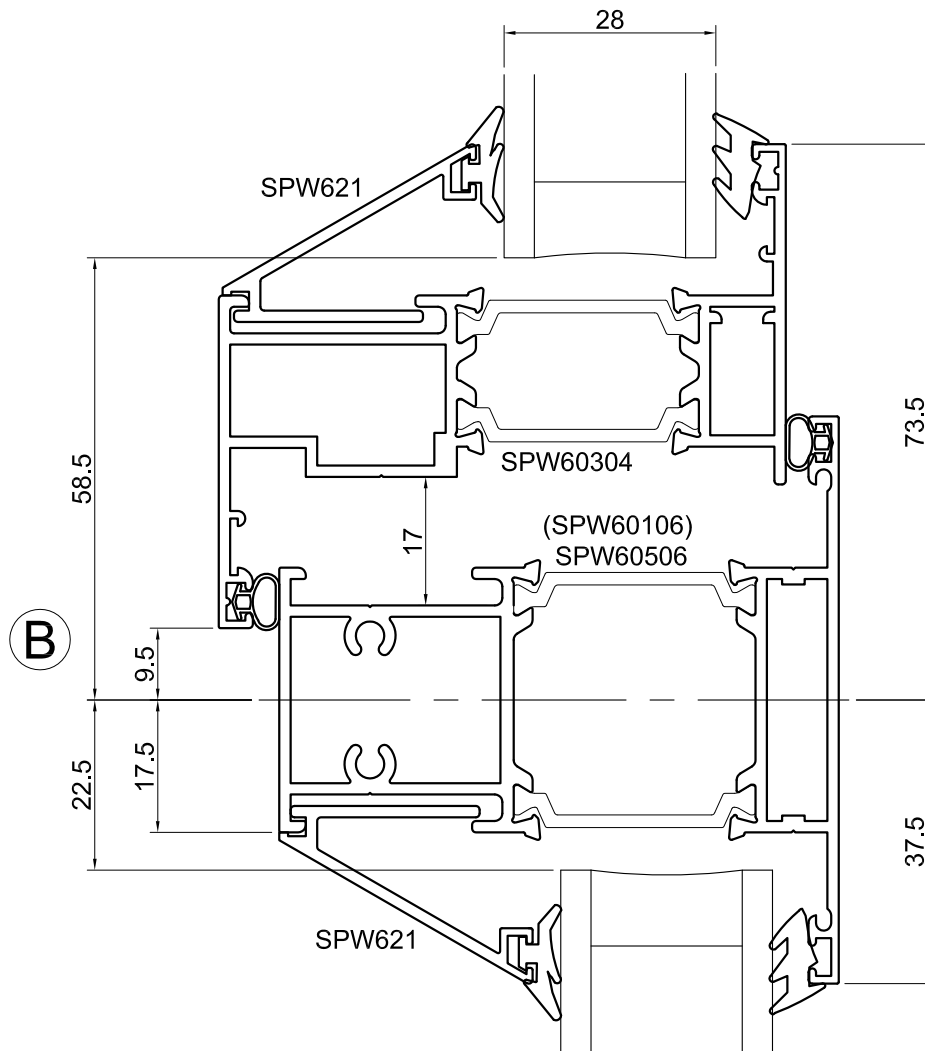

SPW600e.A.103

SPW600e Casement

04.12

Vertical Cross Section - Outward Opening Internal Glazed

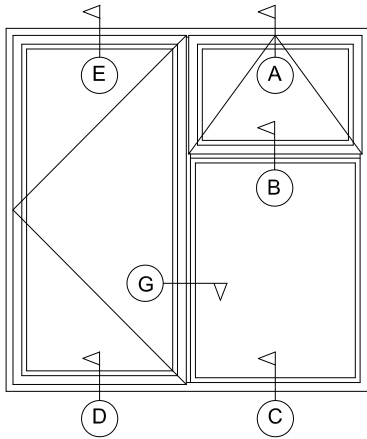

Typical Outside Elevation

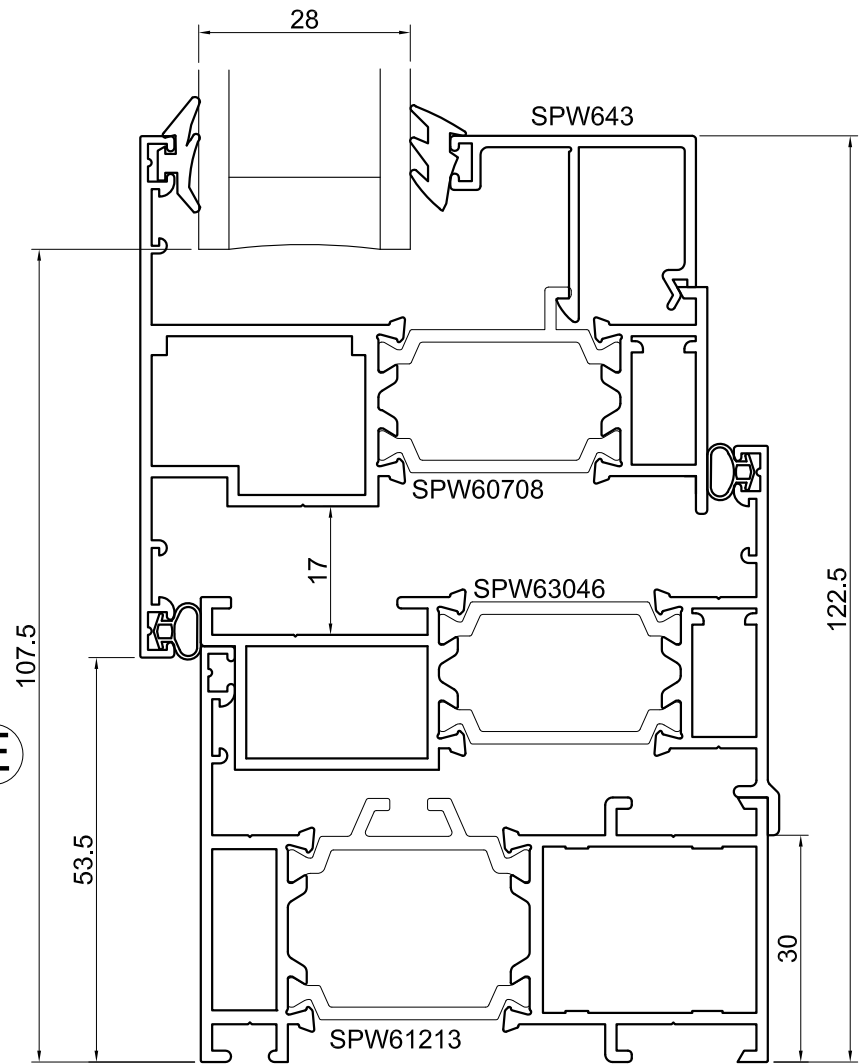

For Alternative Arrangement
See Page SPW600e.A.107

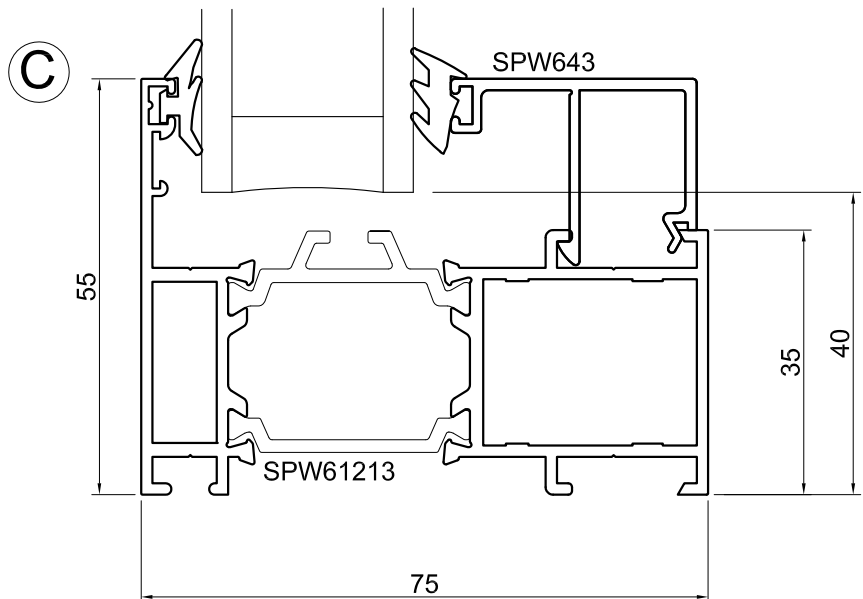

SPW600e.A.105

SPW600e Casement

04.12

Vertical Cross Section - Outward Opening Internal Glazed

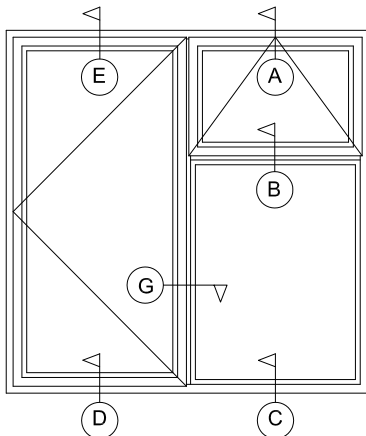

Typical Outside Elevation

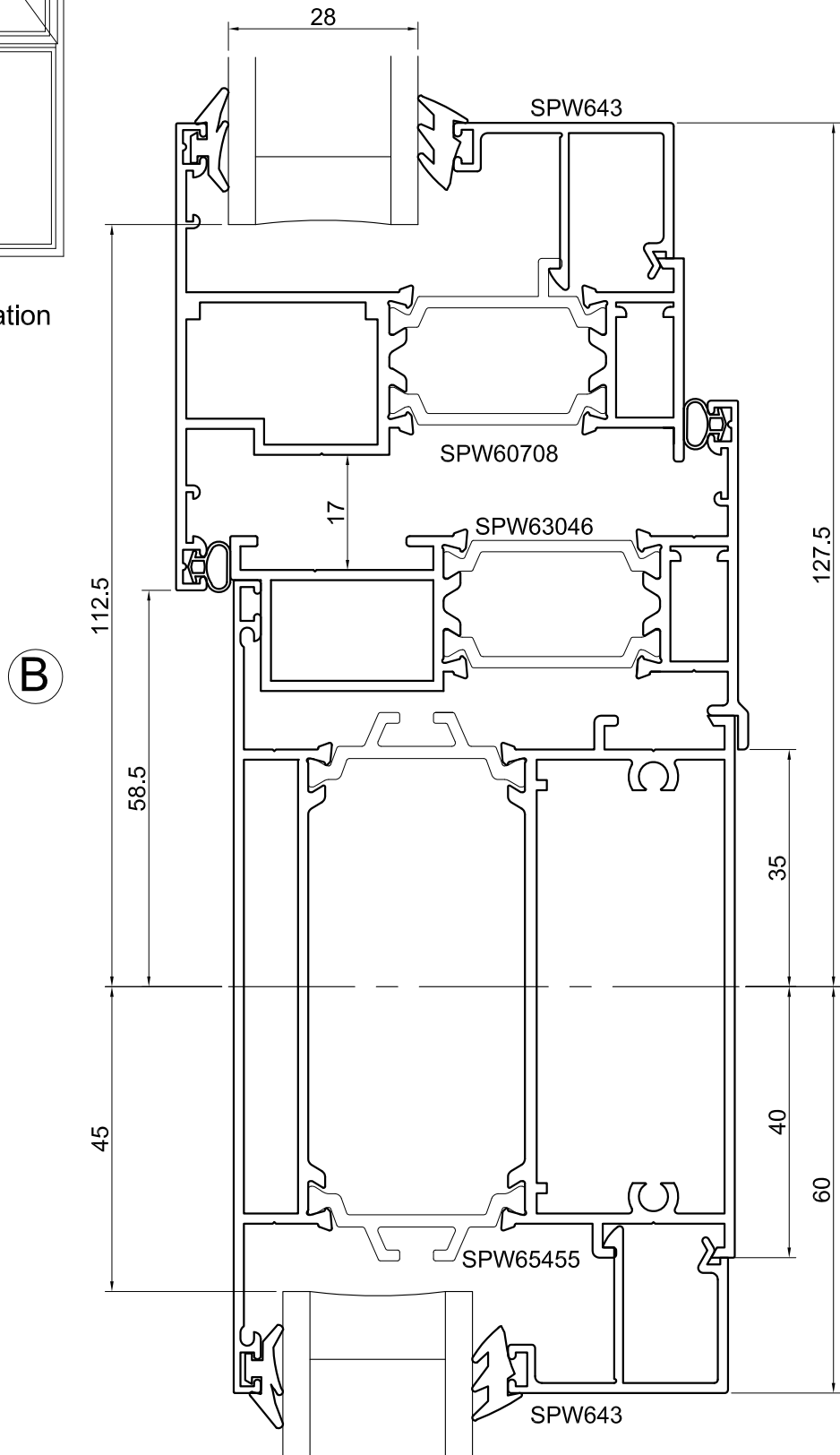

SPW600e Casement

SPW600e.A.106

Vertical Cross Section - Outward Opening Internal Glazed

04.12

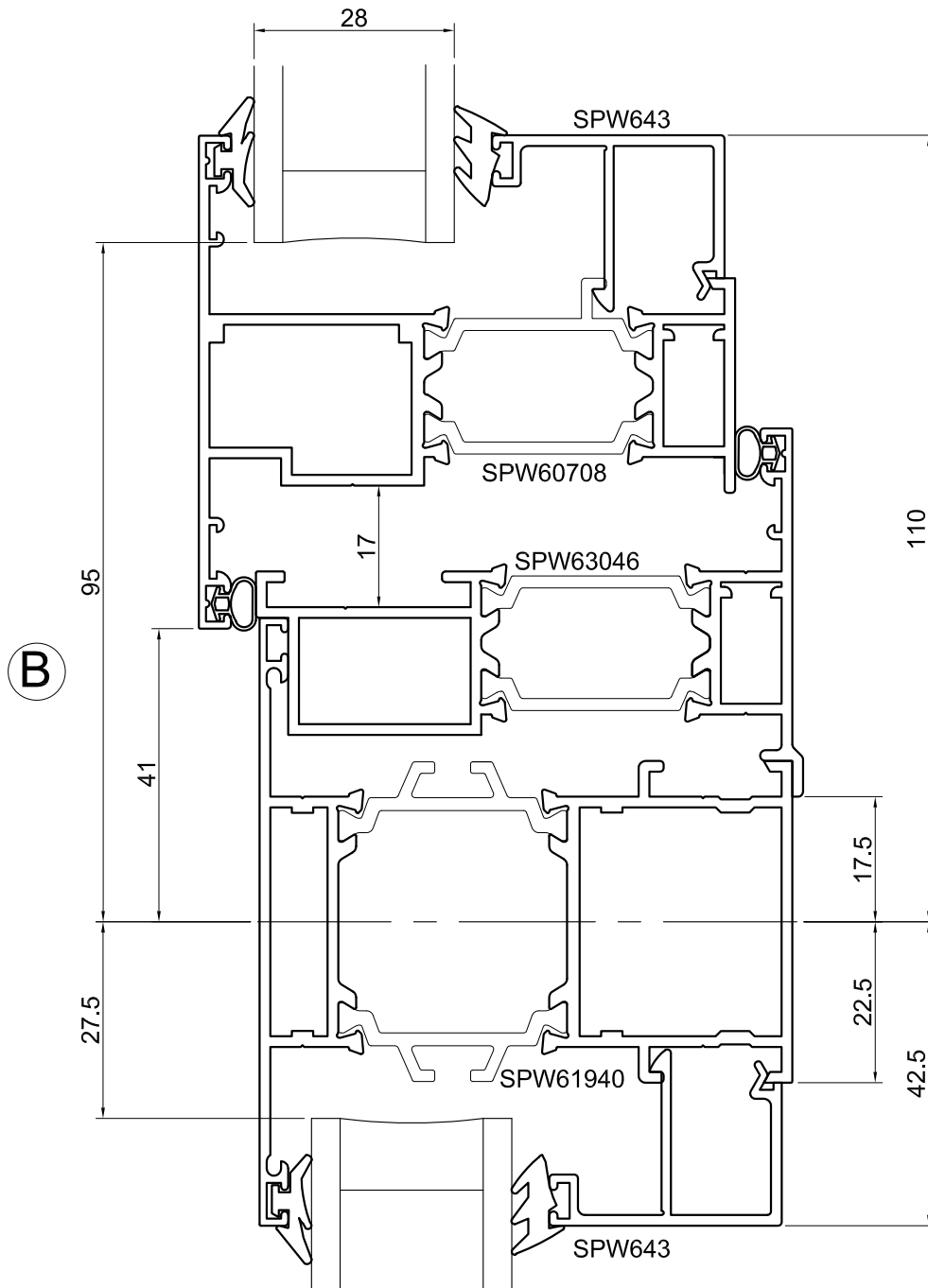

SPW600e.A.107

SPW600e Casement

04.12

Vertical Cross Section - Outward Opening Internal Glazed

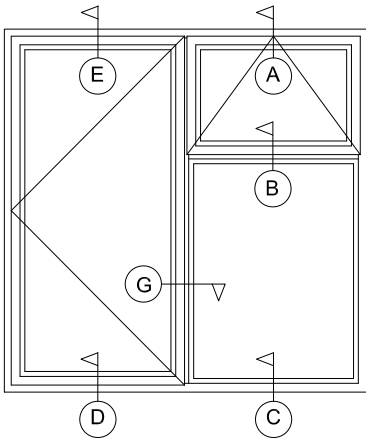

Typical Outside Elevation

A D E

For Alternative Arrangement
See Page SPW600e.A.103

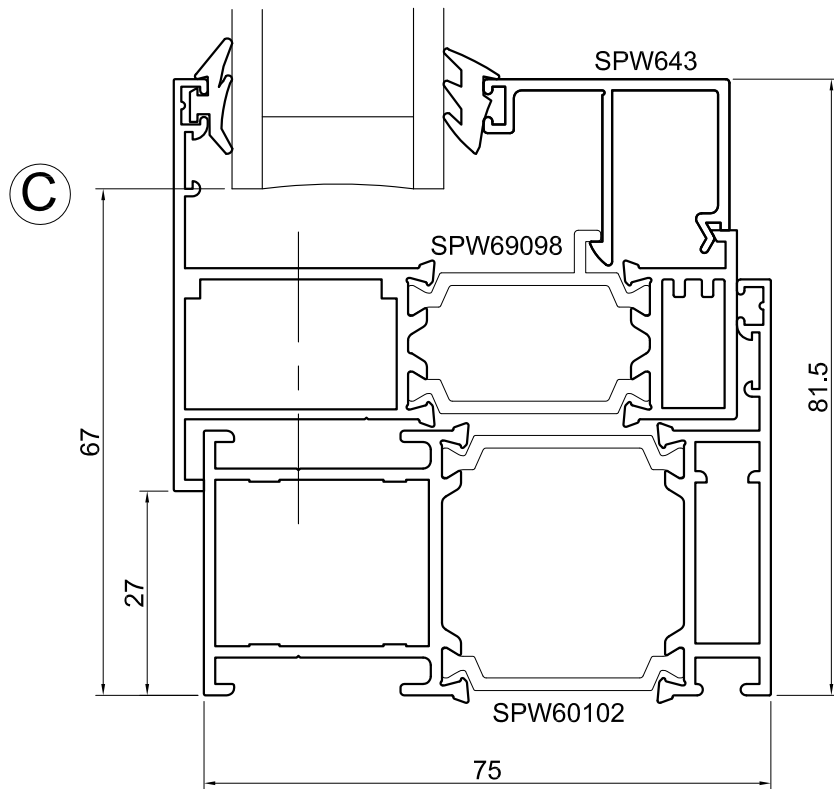
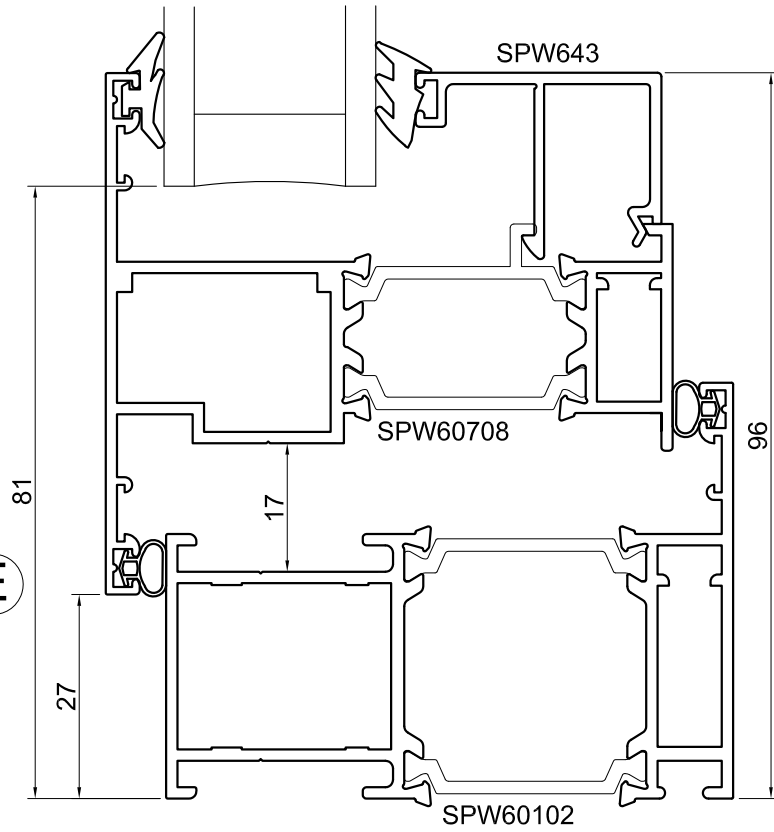

SPW600e.A.109

SPW600e Casement

04.12

Vertical Cross Section - Outward Opening Internal Glazed

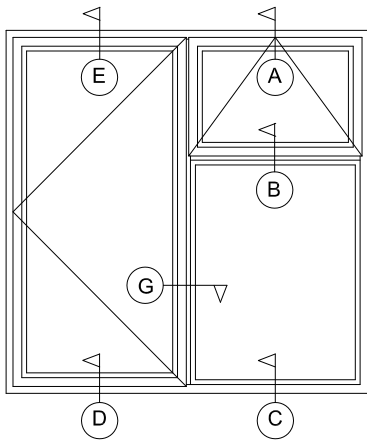

Typical Outside Elevation

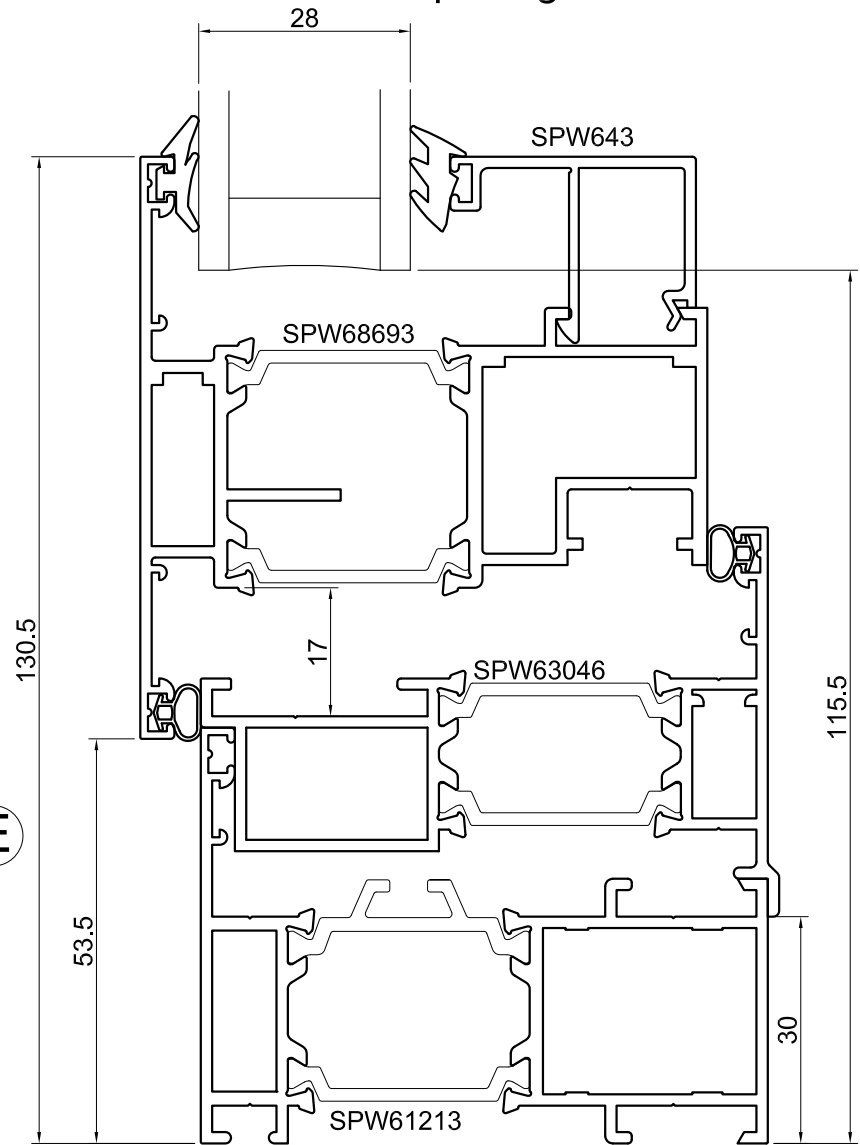

A D E

For Alternative Arrangement
See Page SPW600e.A.113

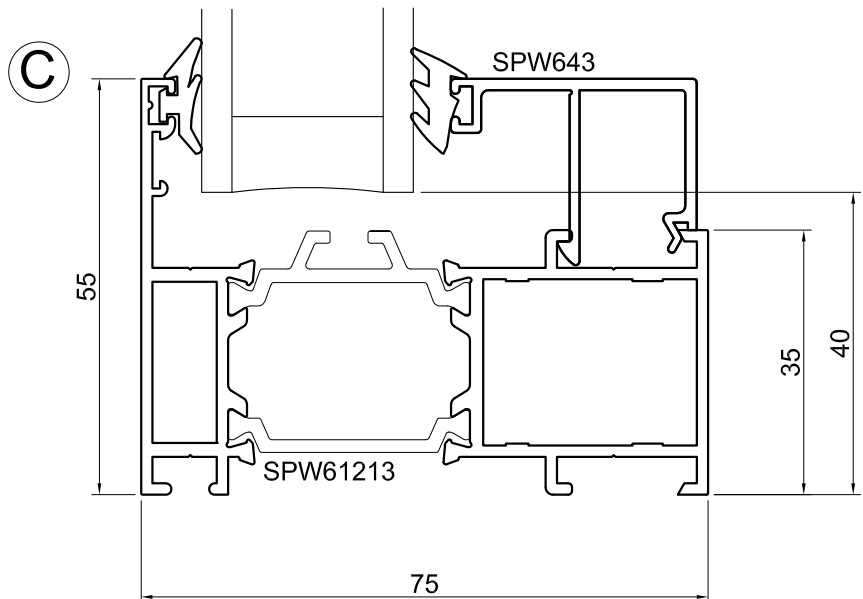

SPW600e.A.111

SPW600e Casement

04.12

Vertical Cross Section - Outward Opening Internal Glazed

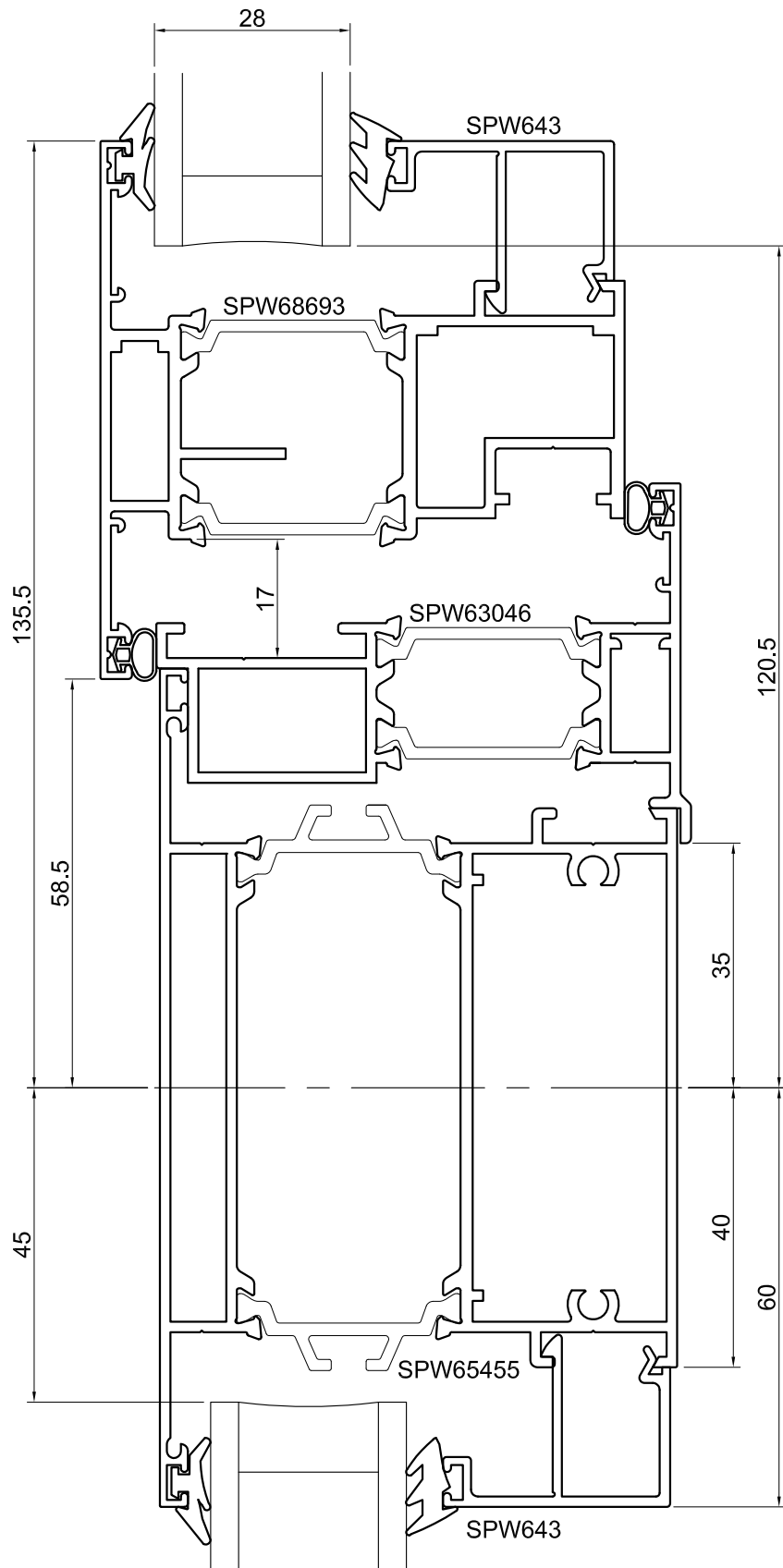
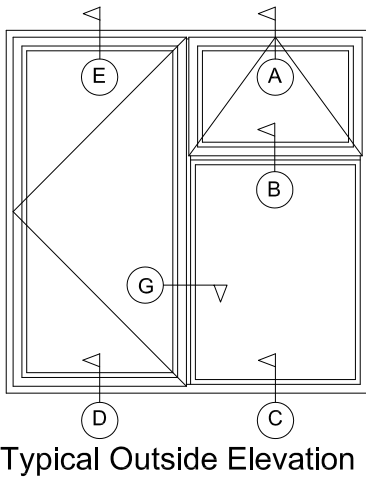

SPW600e Casement

SPW600e.A.112

Vertical Cross Section - Outward Opening Internal Glazed

04.12

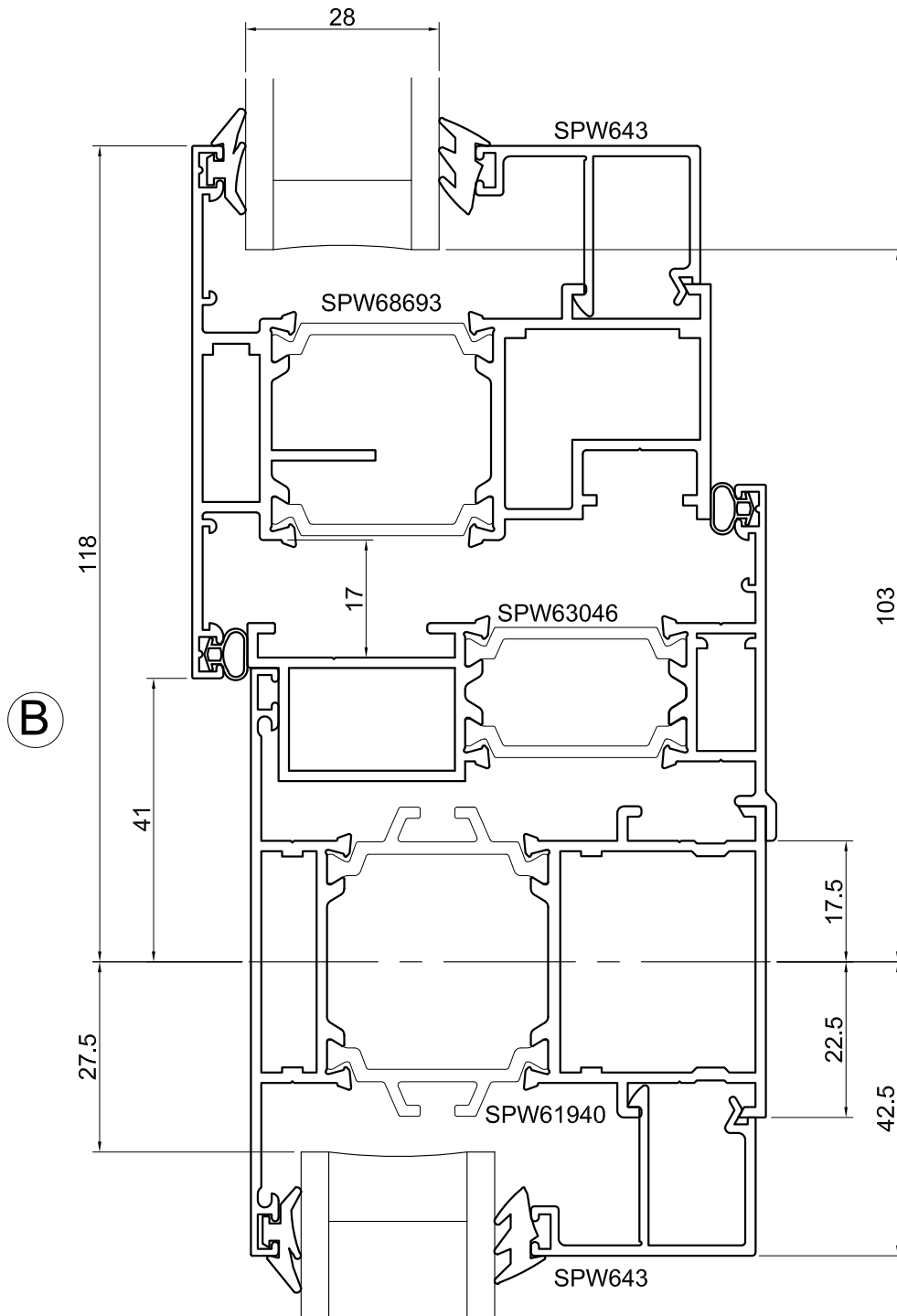

Vertical Cross Section - Outward Opening Internal Glazed

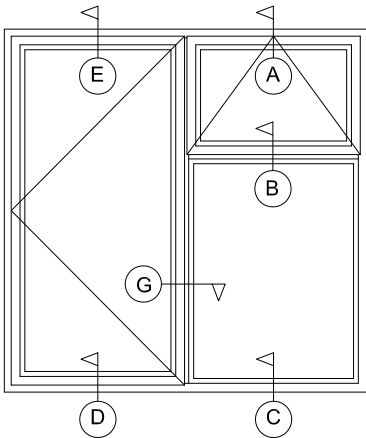

Typical Outside Elevation

(A) (D) (E)

For Alternative Arrangement
See Page SPW600e.A.109

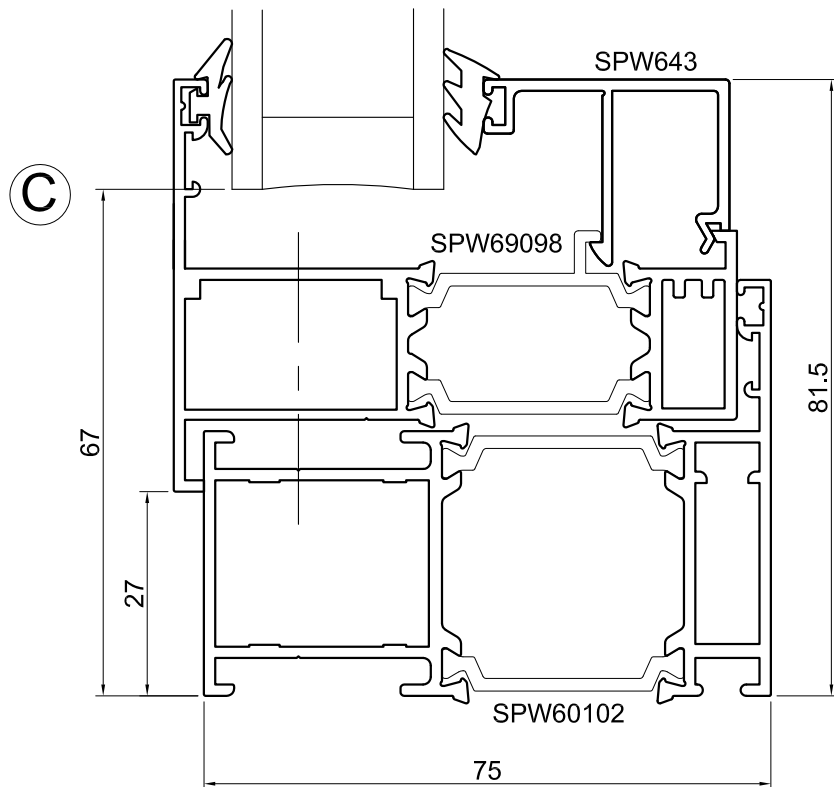
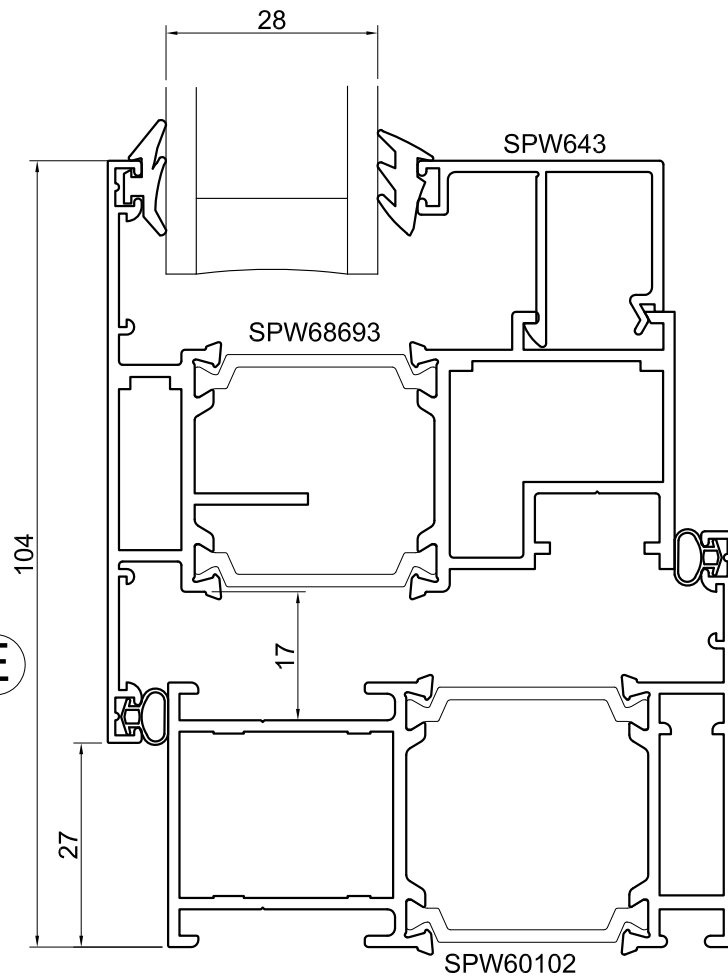

SPW600e Casement

SPW600e.A.114

Vertical Cross Section - Outward Opening Internal Glazed

04.12

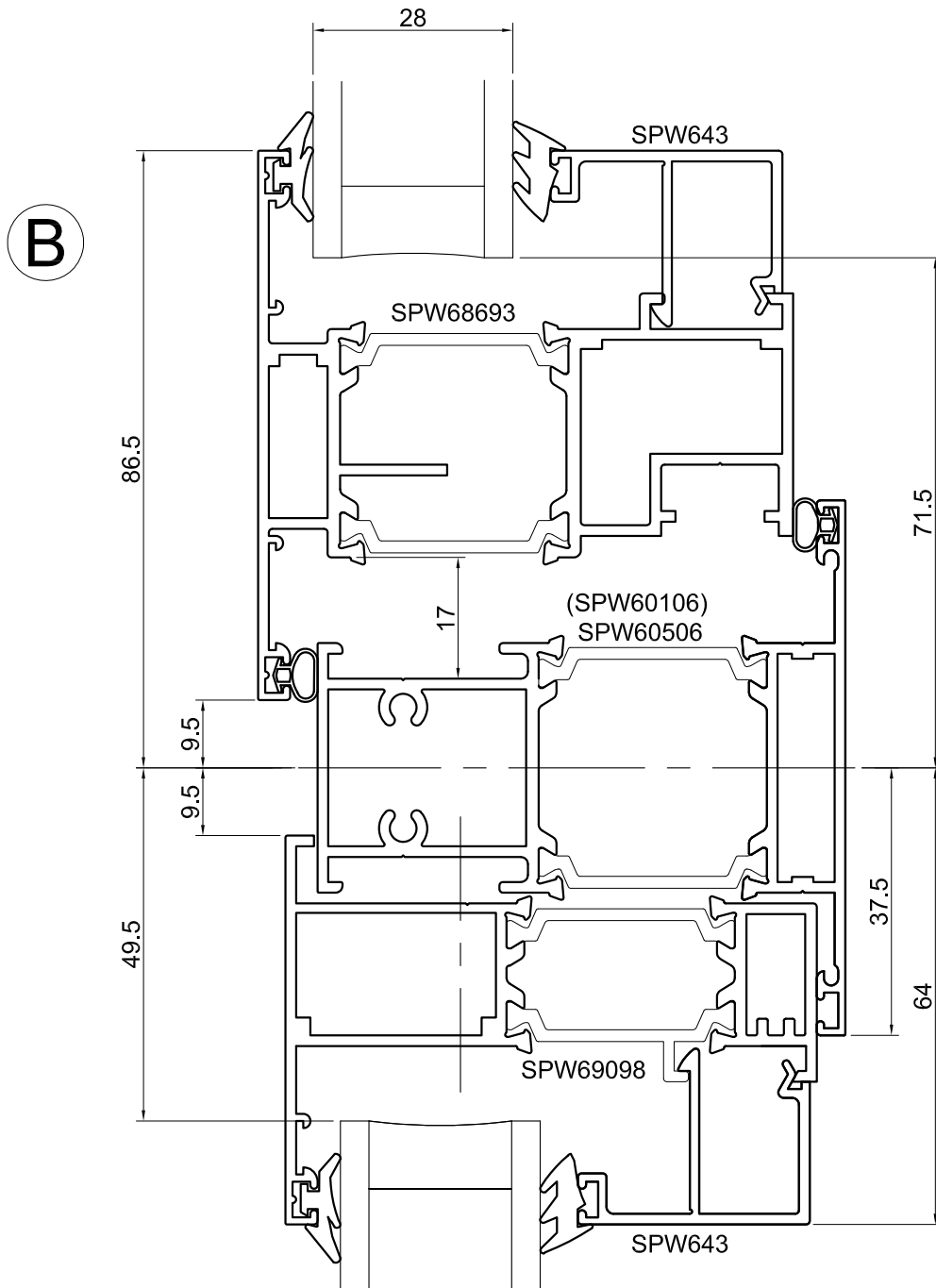

SPW600e.A.115

04.12

SPW600e Casement

Vertical Cross Section - 28mm C/Wall Outer

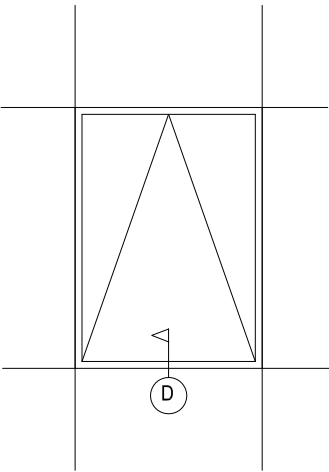

Typical Outside Elevation

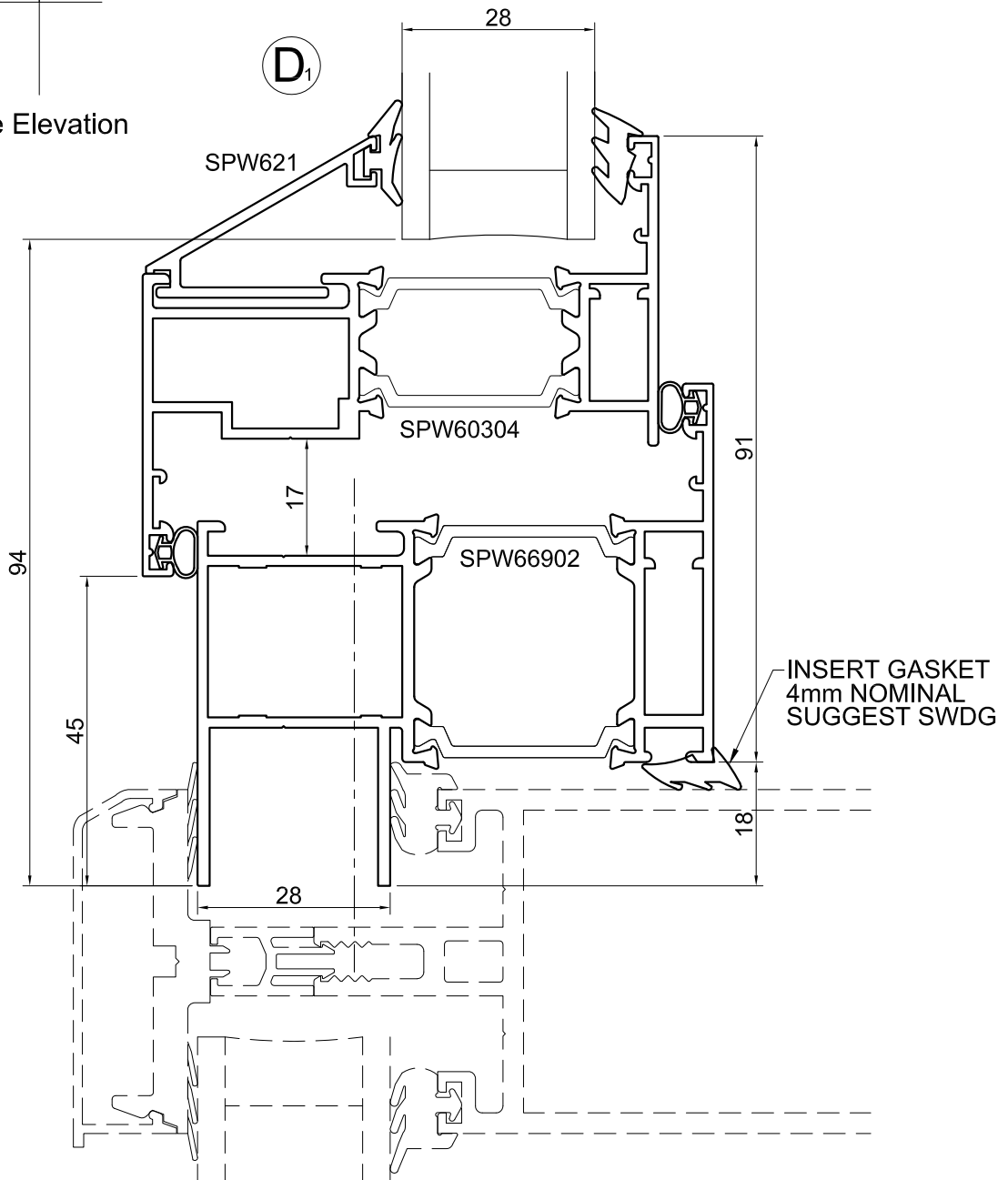

SPW600e Casement

SPW600e.A.116

Vertical Cross Section - 28mm C/Wall Outer

04.12

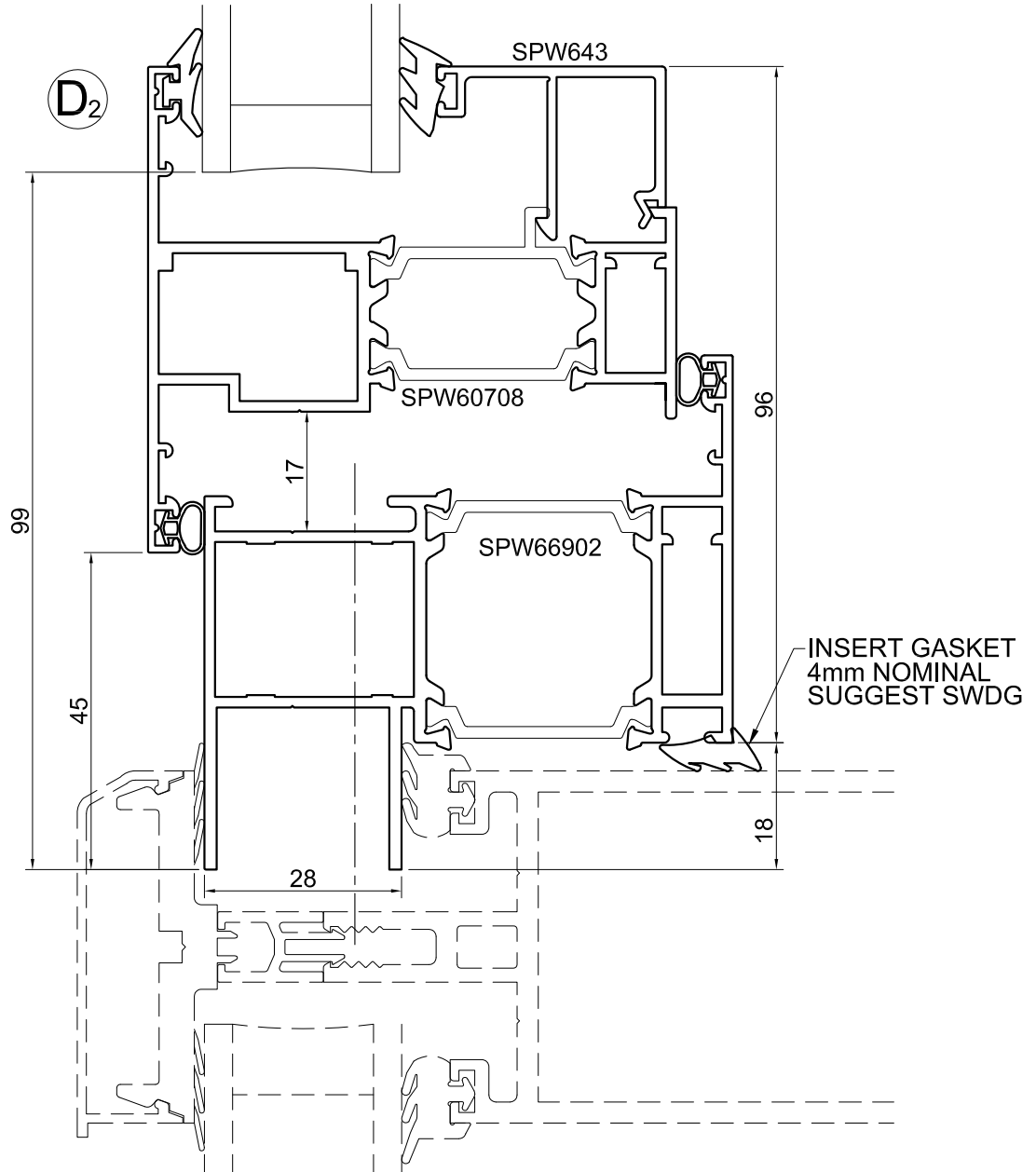

SPW600e.A.117

04.12

SPW600e Casement

Vertical Cross Section - 28mm C/Wall Outer

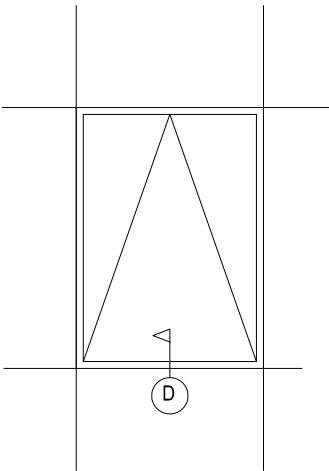

Typical Outside Elevation

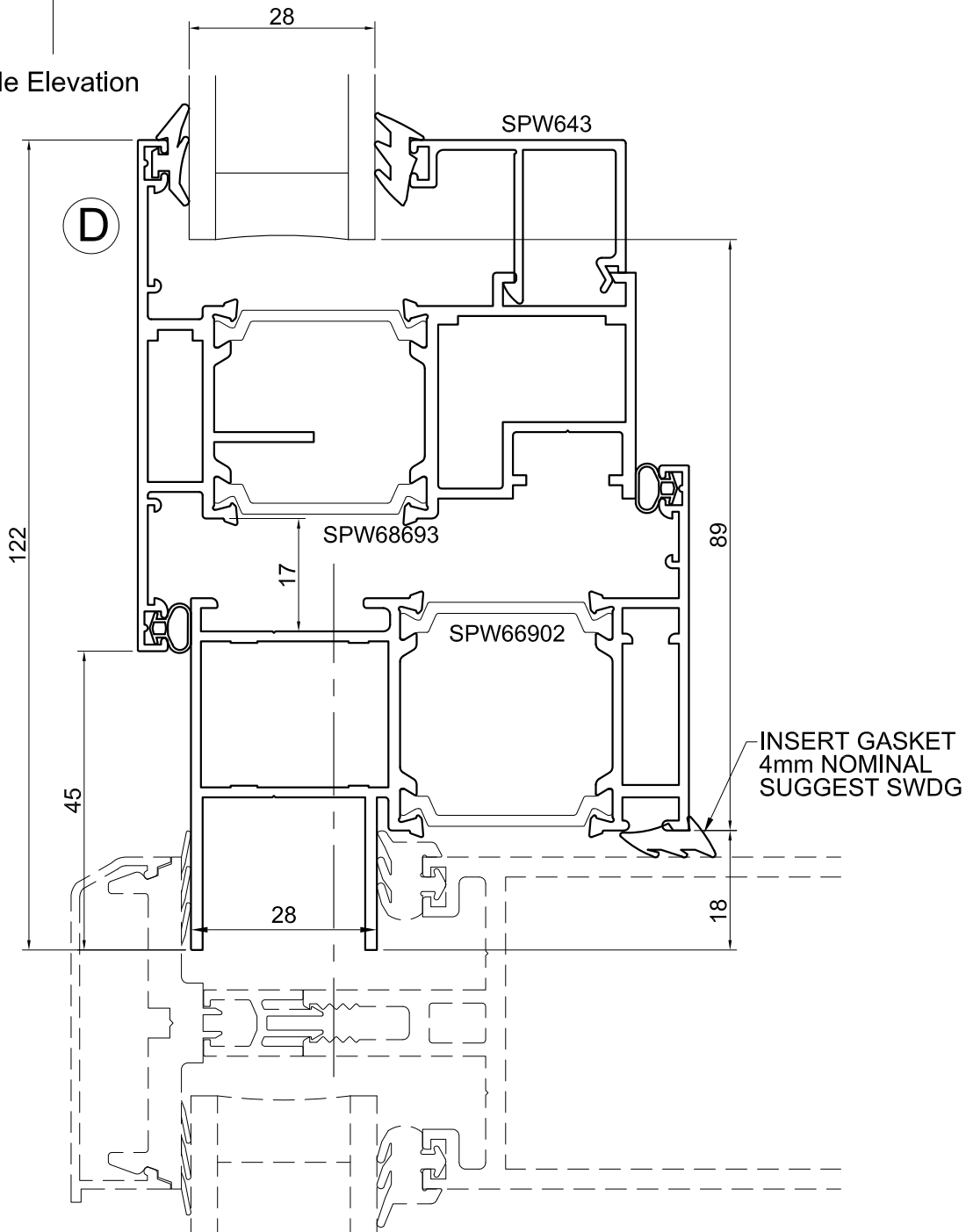

SPW600e Casement

Blank

SPW600e.A.118

04.12

This Page is Intentionally Left Blank

SPW600e.A.119

SPW600e Casement

04.12

Vertical Cross Section - Outward Opening Internal Glazed

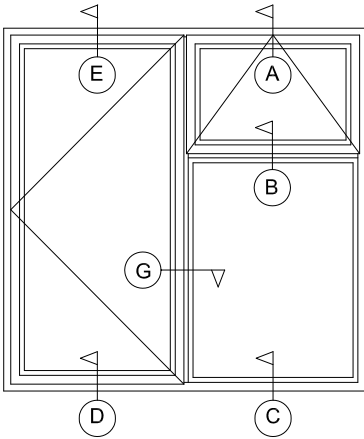

Typical Outside Elevation

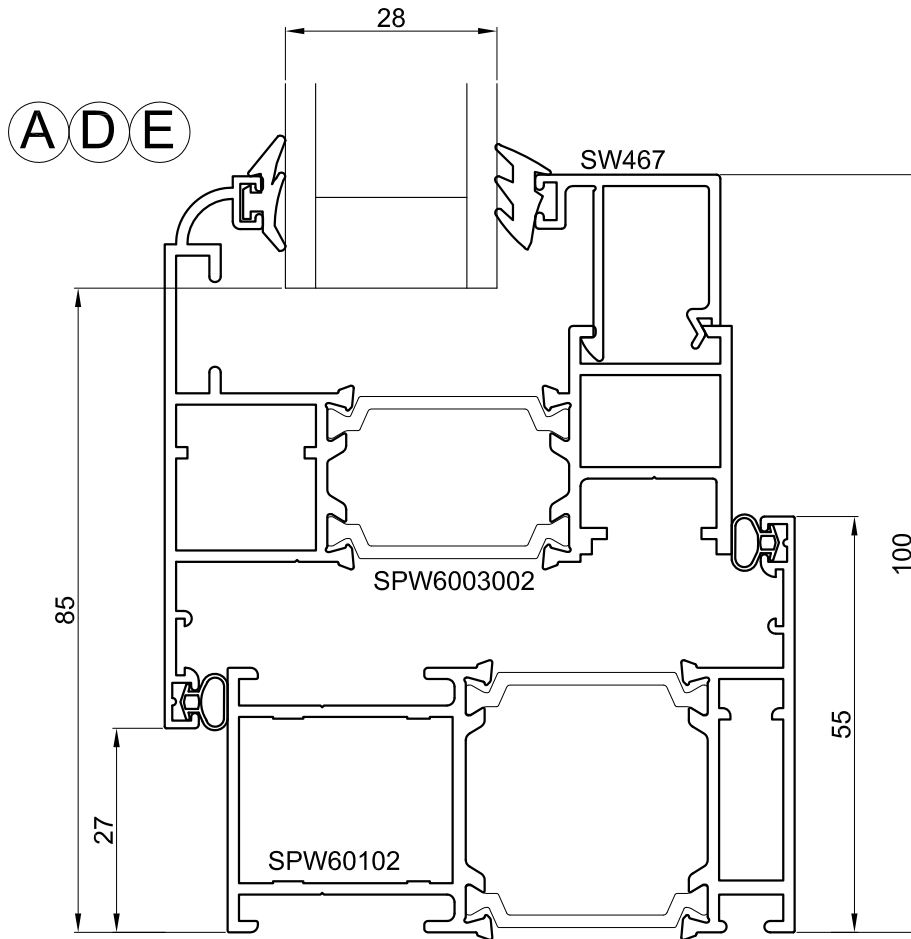

SPW600e Casement

SPW600e.A.120

Vertical Cross Section - Outward Opening Internal Glazed Sash

04.12

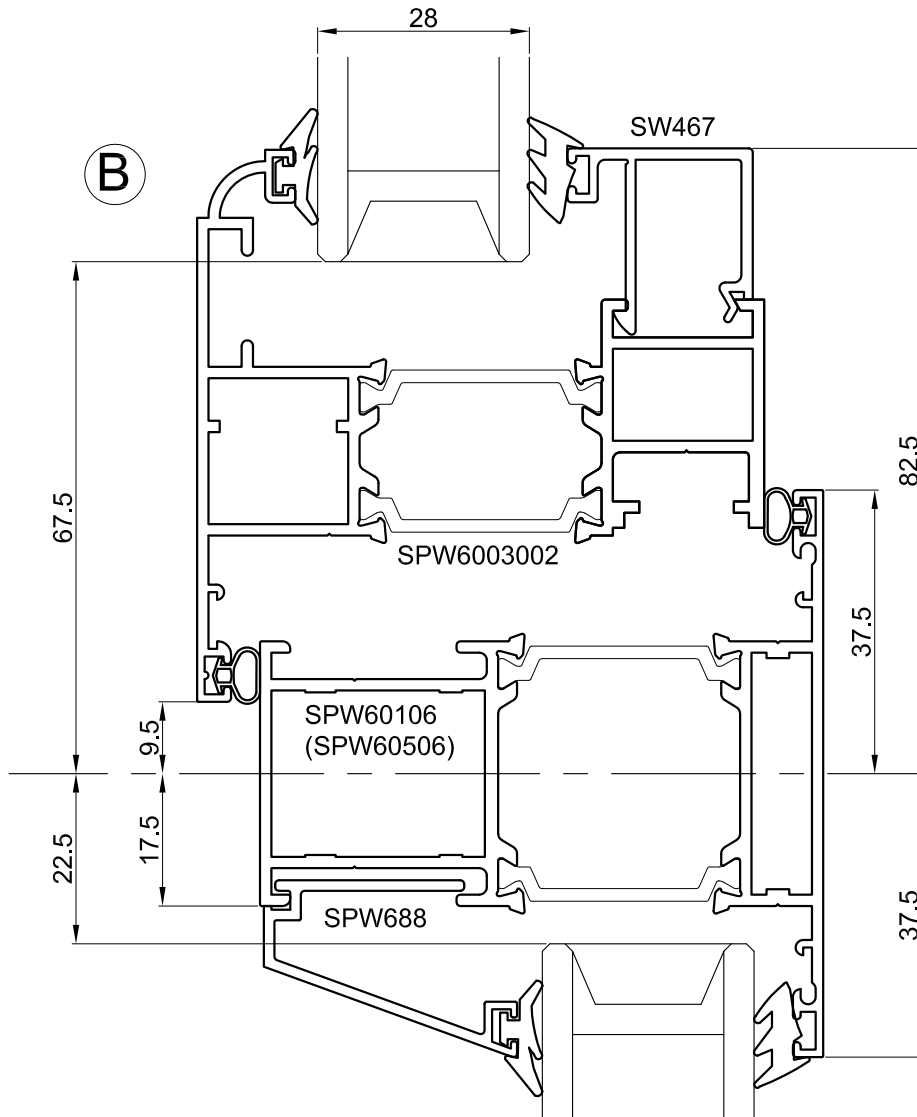

SPW600e.A.121

SPW600e Casement

04.12

Vertical Cross Section - Outward Opening Internal Glazed

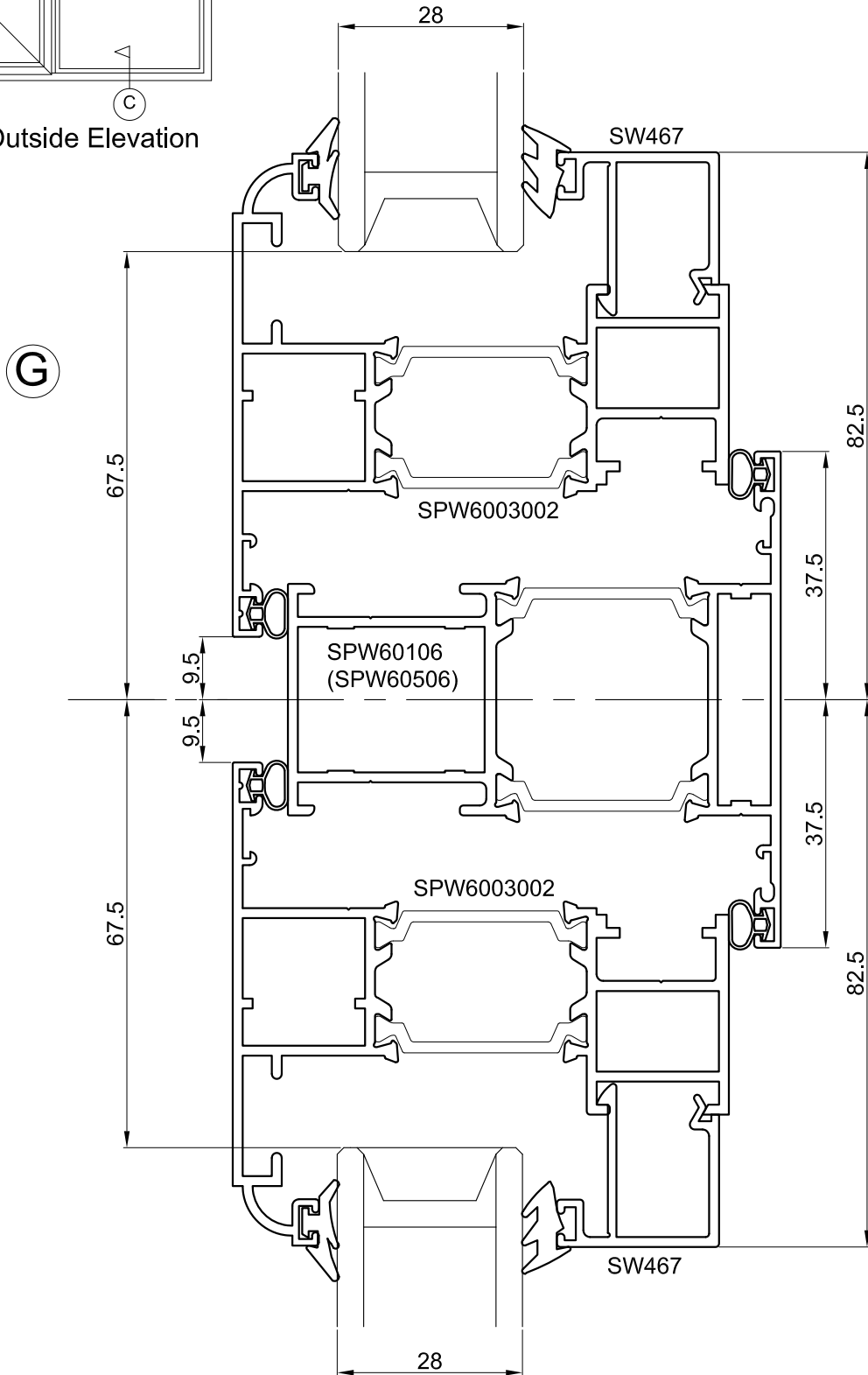
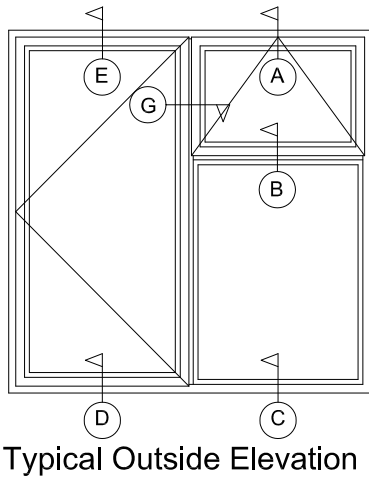

SPW600e Casement

SPW600e.A.122

Vertical Cross Section - 28mm C/Wall Outer

04.12

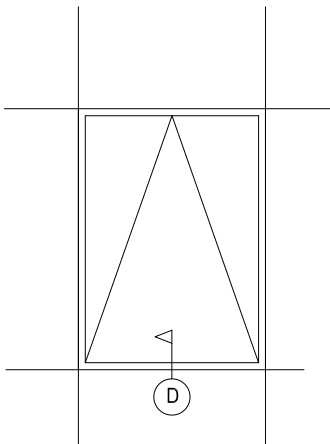



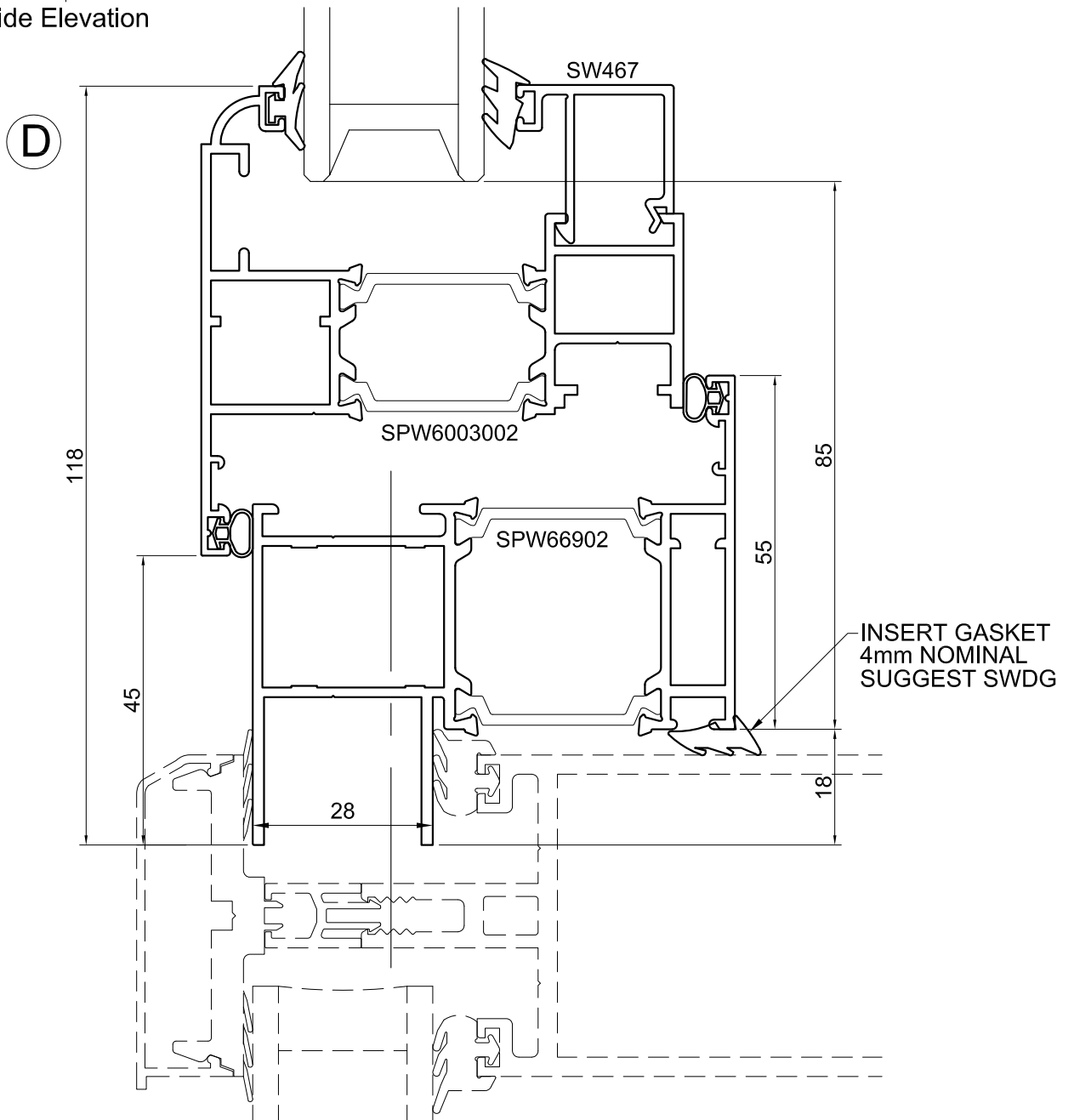

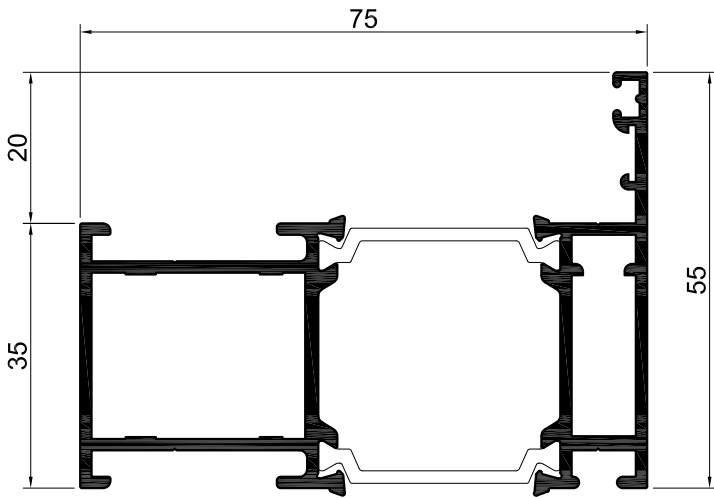
Typical Outside Elevation





SPW60102
Casement Outer

Casement Outer

ALUMINIUM INNER	SPW602
ALUMINIUM OUTER	SPW601
EXTERNAL PERIMETER INNER	200mm
INTERNAL PERIMETER INNER	75mm
EXTERNAL PERIMETER OUTER	204mm
INTERNAL PERIMETER OUTER	102mm
OVERALL EXTERNAL PERIMETER	344mm
POLYAMIDE UPPER	PAW939700
POLYAMIDE LOWER	PAW939700
	PV01
	PH01
CHEVRON	SW4CH7or CHEV7P
	SW445CT8
	SW445CT28
I_{xx} ←	34.1628cm ⁴
I_{yy} ↑	8.7355cm ⁴



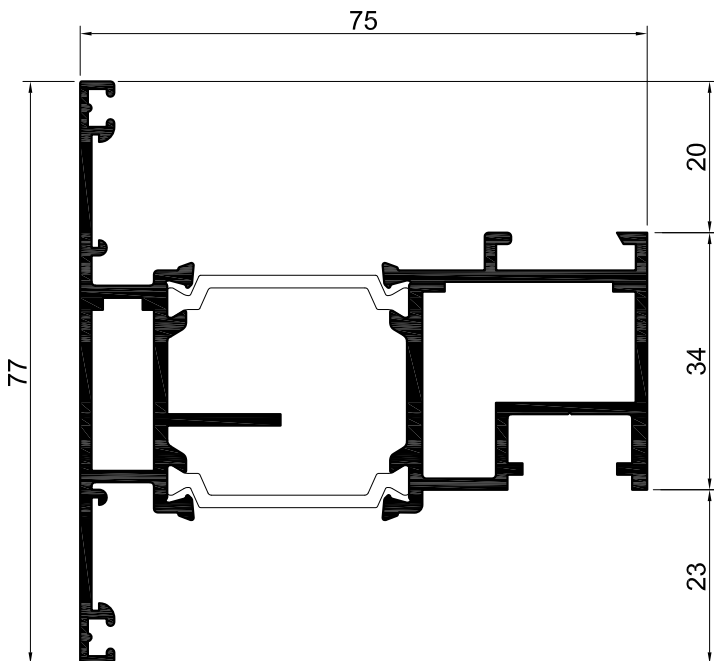

EPS Inserts

EPS In To Thermal Break	EPS001
EPS Under Glass (Fixed Light Only)	EPS006



SPW68693
Espag Vent

Espag Vent

ALUMINIUM INNER	SPW693
ALUMINIUM OUTER	SPW686
EXTERNAL PERIMETER INNER	210mm
INTERNAL PERIMETER INNER	108mm
EXTERNAL PERIMETER OUTER	291mm
INTERNAL PERIMETER OUTER	62mm
OVERALL EXTERNAL PERIMETER	417mm
POLYAMIDE UPPER	PAW939700
POLYAMIDE LOWER	PAW939700
	PV11
	PH12
CHEVRON	SW4CH15or CHEV15P
	SW445CT8
	SPW645CT28
I_{xx} ←	34.1628cm ⁴
I_{yy} ↑	8.7355cm ⁴

EPS Inserts

EPS In To Thermal Break	EPS002
EPS Under Glass	EPS005

SPW600e Casement

Section Identification



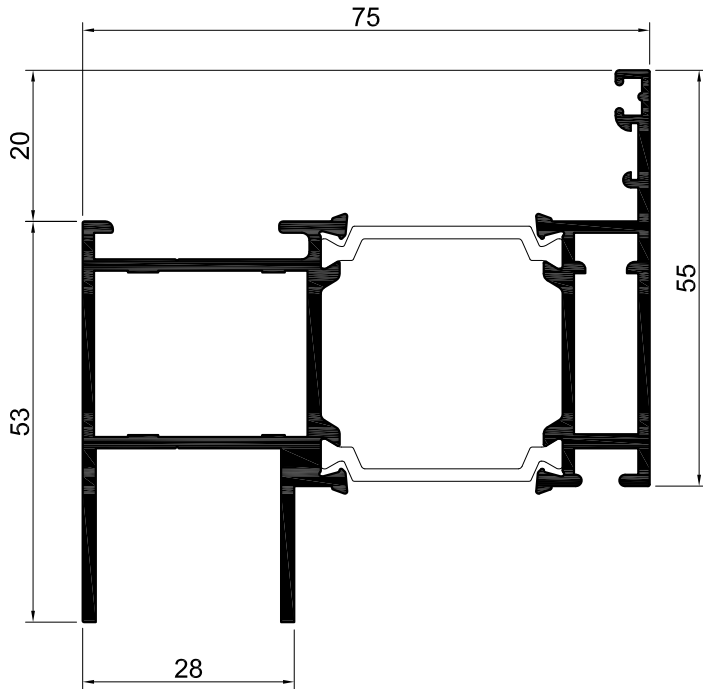

SPW600e.B.102

04.12



SPW66902
28mm Curtain Wall Casement Outer

Curtain Wall Casement Outer

ALUMINIUM INNER	SPW602
ALUMINIUM OUTER	SPW669
EXTERNAL PERIMETER INNER	200mm
INTERNAL PERIMETER INNER	75mm
EXTERNAL PERIMETER OUTER	274mm
INTERNAL PERIMETER OUTER	102mm
OVERALL EXTERNAL PERIMETER	414mm
POLYAMIDE UPPER	PAW939700
POLYAMIDE LOWER	PAW939700
	PV01
	PH01
CHEVRON	SW4CH7or CHEV7P
	SW445CT8
	SW445CT28
Ixx ←	39.3682cm ⁴
Iyy ↑	13.7668cm ⁴



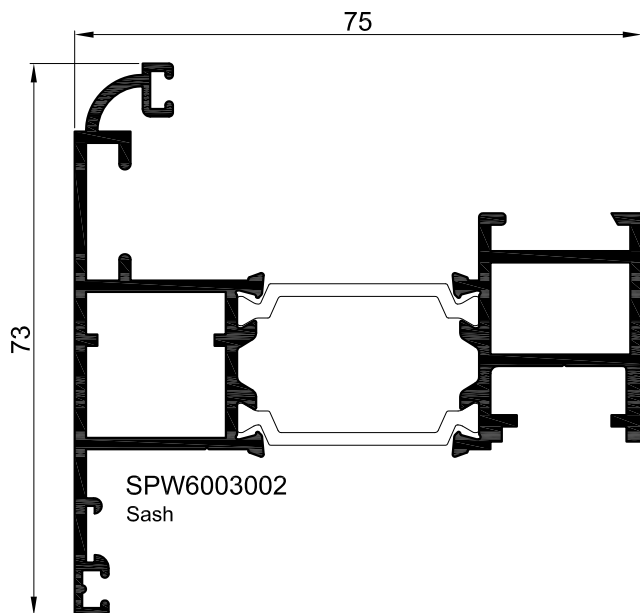

EPS Inserts

EPS In To Thermal Break	EPS001
-------------------------	--------



SPW6003002
Sash

Sash

ALUMINIUM INNER	SPW6002
ALUMINIUM OUTER	SPW6003
EXTERNAL PERIMETER INNER	182mm
INTERNAL PERIMETER INNER	61mm
EXTERNAL PERIMETER OUTER	295mm
INTERNAL PERIMETER OUTER	82mm
OVERALL EXTERNAL PERIMETER	446mm
POLYAMIDE UPPER	PAW939700
POLYAMIDE LOWER	PAW939700
	PV35
	PH24
CHEVRON	SW4CH7or CHEV7P
	SXTW281CT18
	SXTW281CT18
	SH881A
Ixx ←	36.7461cm ⁴
Iyy ↑	11.1272cm ⁴



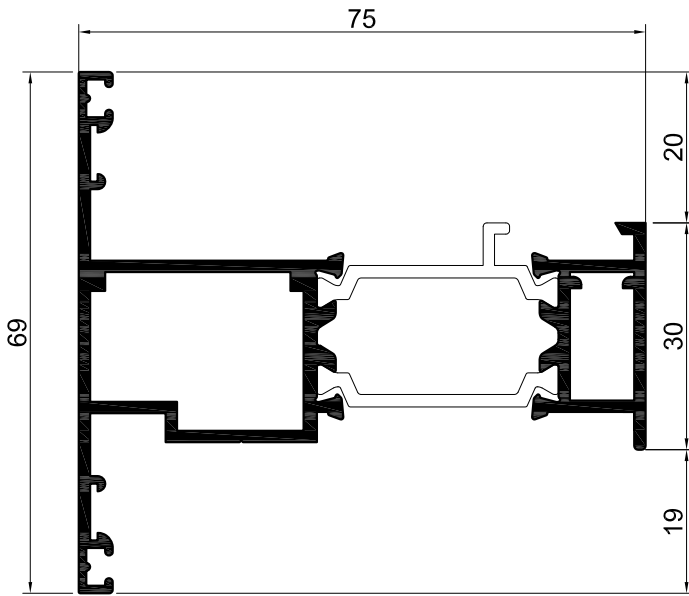

EPS Inserts

EPS In To Thermal Break	EPS003
EPS Under Glass	EPS005



SPW60708
Internal Glazed Vent

Internal Glazed Vent

ALUMINIUM INNER	SPW608
ALUMINIUM OUTER	SPW607
EXTERNAL PERIMETER INNER	119mm
INTERNAL PERIMETER INNER	56mm
EXTERNAL PERIMETER OUTER	282mm
INTERNAL PERIMETER OUTER	98mm
OVERALL EXTERNAL PERIMETER	389mm
POLYAMIDE UPPER	PAW2161HKN
POLYAMIDE LOWER	PAW939700
	PV02
	PH04b
CHEVRONS	SW4CH7or CHEV7P
	SPW645CT8
	SPW645CT28
Ixx ←	32.5104cm ⁴
Iyy ↑	7.9159cm ⁴



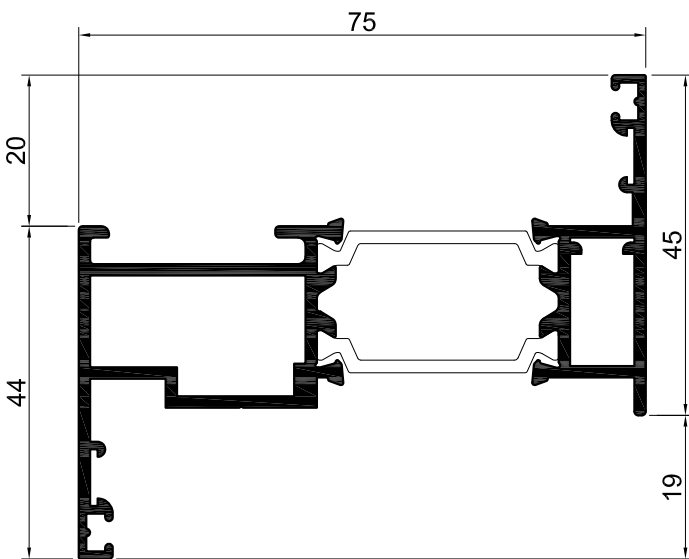

EPS Inserts

EPS In To Thermal Break	EPS004
EPS Under Glass (Fixed Light Only)	EPS005



SPW60304
Casement Vent

Casement Vent

ALUMINIUM INNER	SPW604
ALUMINIUM OUTER	SPW603
EXTERNAL PERIMETER INNER	163mm
INTERNAL PERIMETER INNER	56mm
EXTERNAL PERIMETER OUTER	230mm
INTERNAL PERIMETER OUTER	89mm
OVERALL EXTERNAL PERIMETER	366mm
POLYAMIDE UPPER	PAW939700
POLYAMIDE LOWER	PAW939700
	PV01
	PH02a
CHEVRONS	SW4CH7or CHEV7P
	SXTW281CT28
	SPW645CT8
Ixx ←	32.8863cm ⁴
Iyy ↑	6.3512cm ⁴

EPS Inserts

EPS In To Thermal Break	EPS004
EPS Under Glass (Fixed Light Only)	EPS006

SPW600e Casement

Section Identification

SPW600e.B.104

04.12

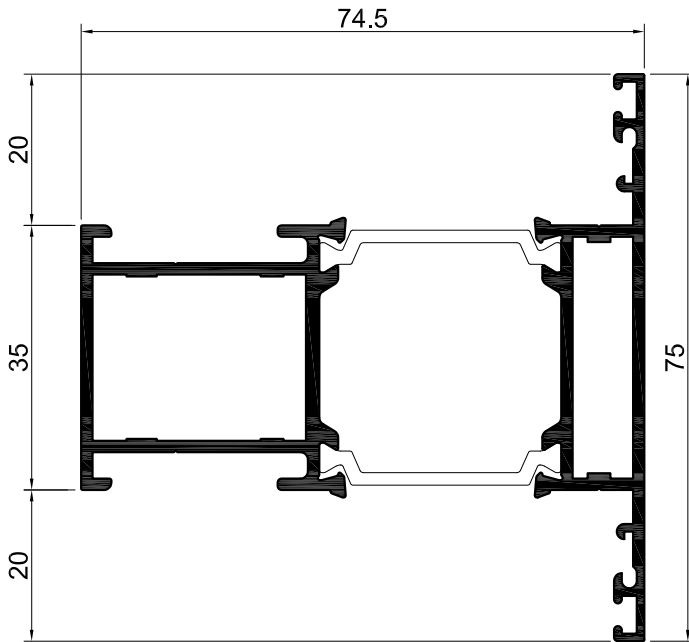

SPW60106
Transom/Mullion

Transom/Mullion - Shearblock

ALUMINIUM INNER	SPW606
ALUMINIUM OUTER	SPW601
EXTERNAL PERIMETER INNER	235mm
INTERNAL PERIMETER INNER	83mm
EXTERNAL PERIMETER OUTER	204mm
INTERNAL PERIMETER OUTER	102mm
OVERALL EXTERNAL PERIMETER	385mm
POLYAMIDE UPPER	PAW939700
POLYAMIDE LOWER	PAW939700
CHEVRONS	SW4CH7or CHEV7P



SPW650CT30



SPW651CT21



SPW677CUT ⊗

Ixx ←
Iyy ↑

35.8991cm⁴
11.7143cm⁴

⊗ This shear block not suitable for cruciform arrangements

EPS Inserts

EPS In To Thermal Break	EPS001
EPS Under Glass (Fixed Light Only)	EPS006

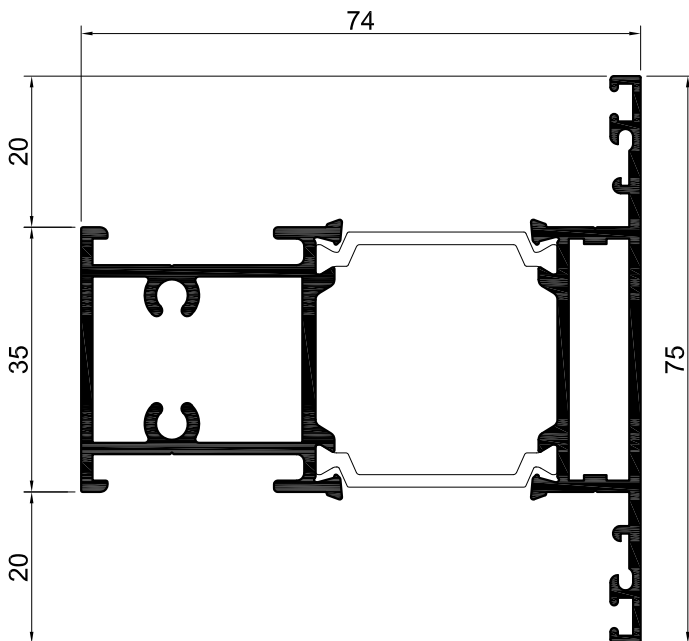

SPW60506
Transom/Mullion - Screwport

Transom/Mullion - Screwport

ALUMINIUM INNER	SPW606
ALUMINIUM OUTER	SPW605
EXTERNAL PERIMETER INNER	235mm
INTERNAL PERIMETER INNER	83mm
EXTERNAL PERIMETER OUTER	200mm
INTERNAL PERIMETER OUTER	138mm
OVERALL EXTERNAL PERIMETER	385mm
POLYAMIDE UPPER	PAW939700
POLYAMIDE LOWER	PAW939700
CHEVRONS	SW4CH7or CHEV7P



SPW650CT30



SPW677CUT ⊗

Ixx ←
Iyy ↑

37.9491cm⁴
11.8320cm⁴

⊗ This shear block not suitable for cruciform arrangements



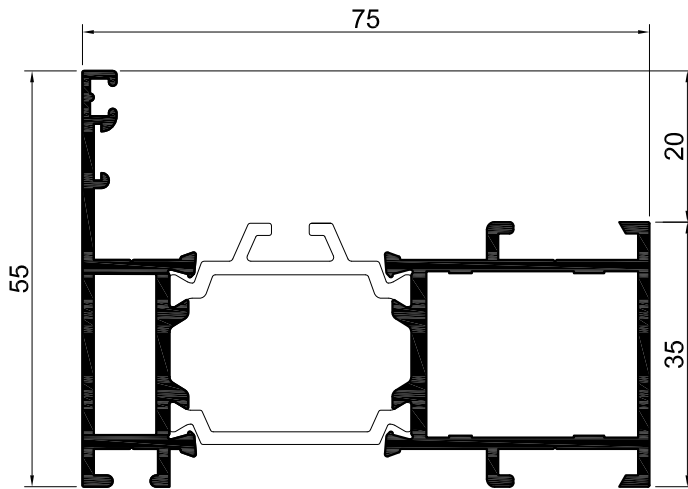

EPS Inserts

EPS In To Thermal Break	EPS001
EPS Under Glass (Fixed Light Only)	EPS006



SPW61213
Outer Frame

Outer Frame

ALUMINIUM INNER	SPW613
ALUMINIUM OUTER	SPW612
EXTERNAL PERIMETER INNER	196mm
INTERNAL PERIMETER INNER	102mm
EXTERNAL PERIMETER OUTER	200mm
INTERNAL PERIMETER OUTER	59mm
OVERALL EXTERNAL PERIMETER	387mm
POLYAMIDE UPPER	PAW216100
POLYAMIDE LOWER	PAW939700
	PV02A+TCRIMPS7.6
	PH01
CHEVRON	SW4CH7or CHEV7P
	SW445-CT8
	SW445-CT28
I_{xx} ←	34.3018cm ⁴
I_{yy} ↑	7.7189cm ⁴

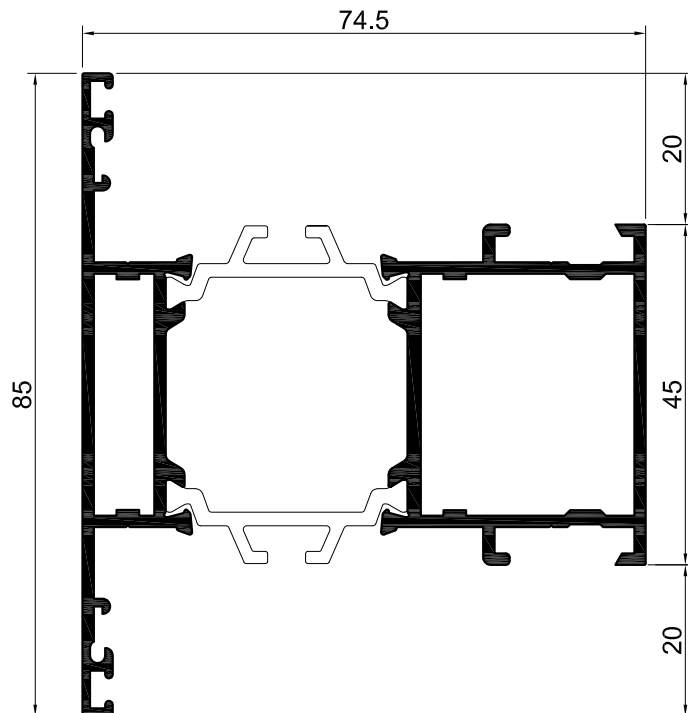

EPS Inserts

EPS In To Thermal Break	EPS003
EPS Under Glass (Fixed Light Only)	EPS006



SPW61940
Transom/Mullion Heavy Duty

Transom/Mullion Heavy Duty

ALUMINIUM INNER	SPW640
ALUMINIUM OUTER	SPW619
EXTERNAL PERIMETER INNER	217mm
INTERNAL PERIMETER INNER	125mm
EXTERNAL PERIMETER OUTER	255mm
INTERNAL PERIMETER OUTER	83mm
OVERALL EXTERNAL PERIMETER	471mm
POLYAMIDE UPPER	PAW216100
POLYAMIDE LOWER	PAW216100
CHEVRONS	SW4CH7or CHEV7P
	SPW650-CT30
	SPW652-CT30
	SPW677-CUT ⊗
I_{xx} ←	40.8522cm ⁴
I_{yy} ↑	17.1353cm ⁴

⊗ This shear block not suitable for cruciform arrangements

EPS Inserts

EPS In To Thermal Break	EPS001
EPS Under Glass (Fixed Light Only)	EPS006

SPW600e Casement

Section Identification

SPW600e.B.106

04.12

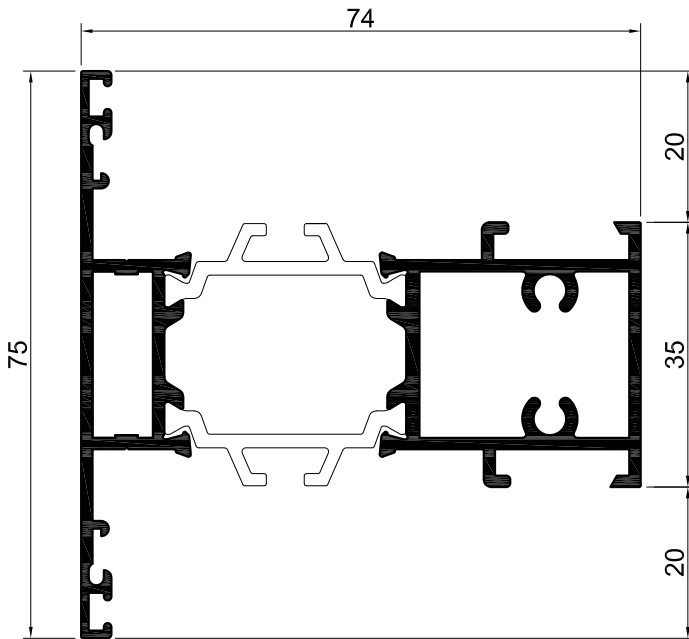

SPW61817
Transom/Mullion - Screwport

Transom/Mullion - Screwport

ALUMINIUM INNER	SPW617
ALUMINIUM OUTER	SPW618
EXTERNAL PERIMETER INNER	194mm
INTERNAL PERIMETER INNER	138mm
EXTERNAL PERIMETER OUTER	235mm
INTERNAL PERIMETER OUTER	61mm
OVERALL EXTERNAL PERIMETER	448mm
POLYAMIDE UPPER	PAW216100
POLYAMIDE LOWER	PAW216100



SPW650-CT21



SPW678-CUT[⊗]

Ixx ←

37.4910cm⁴

Iyy ↑

10.2891cm⁴

[⊗] This shear block not suitable for cruciform arrangements

EPS Inserts

EPS In To Thermal Break	EPS003
EPS Under Glass (Fixed Light Only)	EPS006

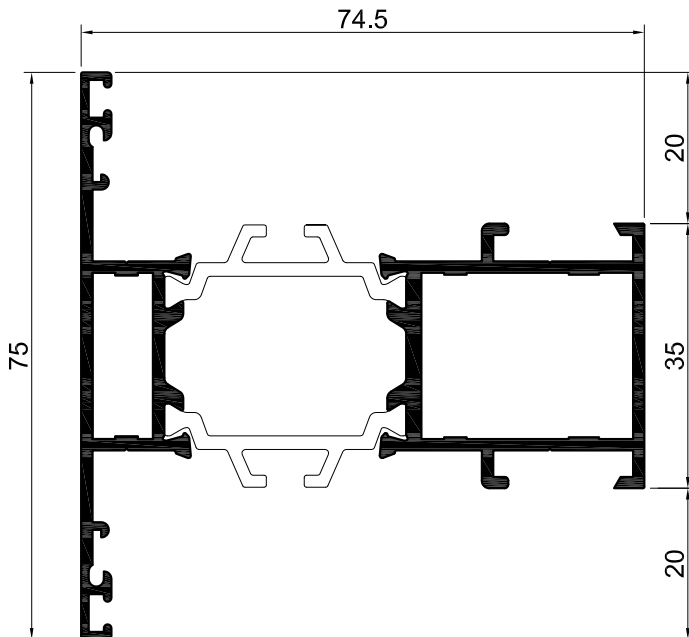

SPW61813
Transom/Mullion - Shearblock

Transom/Mullion - Shearblock

ALUMINIUM INNER	SPW613
ALUMINIUM OUTER	SPW618
EXTERNAL PERIMETER INNER	196mm
INTERNAL PERIMETER INNER	102mm
EXTERNAL PERIMETER OUTER	235mm
INTERNAL PERIMETER OUTER	61mm
OVERALL EXTERNAL PERIMETER	450mm
POLYAMIDE UPPER	PAW216100
POLYAMIDE LOWER	PAW216100



SPW650-CT21



SPW652-CT21



SPW678-CUT[⊗]

Ixx ←

35.6030cm⁴

Iyy ↑

10.1499cm⁴

[⊗] This shear block not suitable for cruciform arrangements

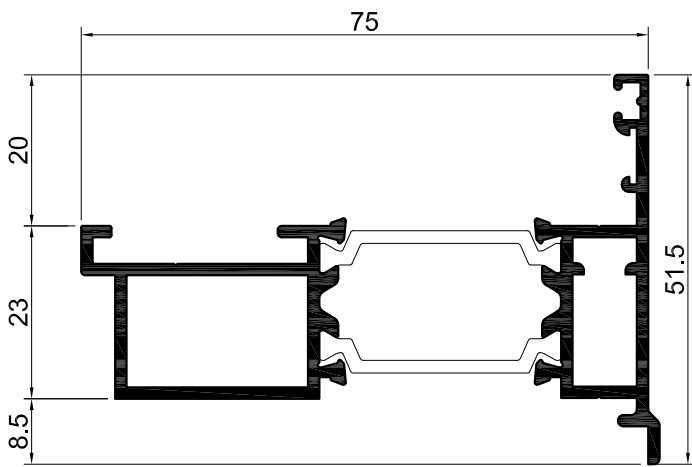

EPS Inserts

EPS In To Thermal Break	EPS003
EPS Under Glass (Fixed Light Only)	EPS006



SPW63046
Casement Internal Glazed Adaptor

Casement Internal Glazed Adaptor

ALUMINIUM INNER	SPW646
ALUMINIUM OUTER	SPW630
EXTERNAL PERIMETER INNER	183mm
INTERNAL PERIMETER INNER	62mm
EXTERNAL PERIMETER OUTER	159mm
INTERNAL PERIMETER OUTER	78mm
OVERALL EXTERNAL PERIMETER	315mm
POLYAMIDE UPPER	PAW939700
POLYAMIDE LOWER	PAW939700
	PV01
	PH04a
CHEVRON	SW4-CH7

	SPW645-CT8
	SPW645-CT24

Ixx ←	24.7700cm ⁴
Iyy ↑	4.2292cm ⁴

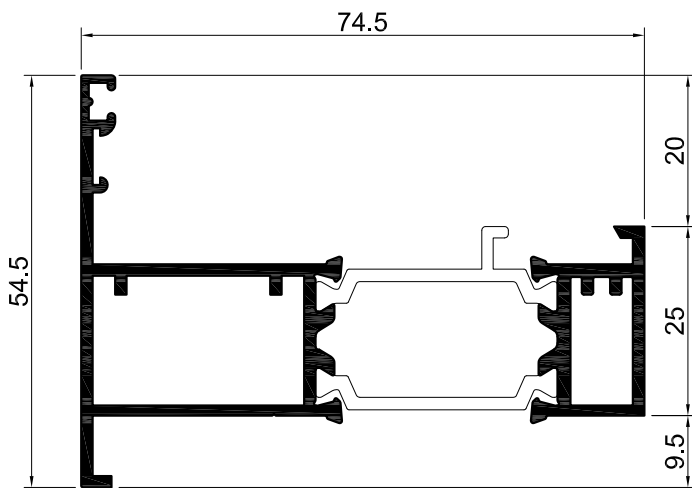

EPS Inserts

EPS In To Thermal Break	EPS004
-------------------------	--------



SPW69098
Internal Glazed Adaptor-Fixed Light

Internal Glazed Adaptor-Fixed Light

ALUMINIUM INNER	SPW698
ALUMINIUM OUTER	SPW690
EXTERNAL PERIMETER INNER	105mm
INTERNAL PERIMETER INNER	59mm
EXTERNAL PERIMETER OUTER	227mm
INTERNAL PERIMETER OUTER	100mm
OVERALL EXTERNAL PERIMETER	317mm
POLYAMIDE UPPER	PAW2161HKN
POLYAMIDE LOWER	PAW939700
	PV02
	PH04b
CHEVRON	SW4-CH7

	SPW645-CT8
	SPW645-CT28

Ixx ←	22.9246cm ⁴
Iyy ↑	4.8732cm ⁴

EPS Inserts

EPS In To Thermal Break	EPS004
EPS Under Glass	EPS005

SPW600e Casement

Section Identification

SPW600e.B.108

04.12

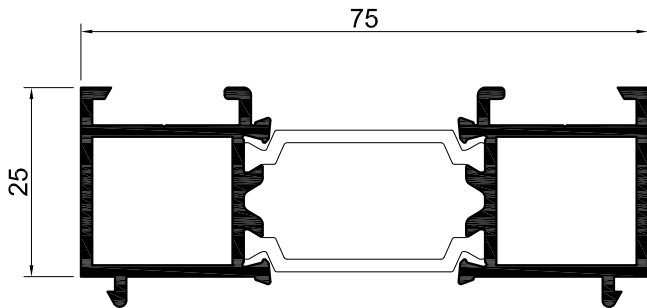

SPW65353
25mm Add-On

25mm Add-On

ALUMINIUM INNER	SPW653
ALUMINIUM OUTER	SPW653
EXTERNAL PERIMETER INNER	147mm
INTERNAL PERIMETER INNER	71mm
EXTERNAL PERIMETER OUTER	147mm
INTERNAL PERIMETER OUTER	71mm
OVERALL EXTERNAL PERIMETER	265mm
POLYAMIDE UPPER	PAW939700
POLYAMIDE LOWER	PAW939700
Ixx ←	24.4084cm ⁴
Iyy ↑	2.5396cm ⁴

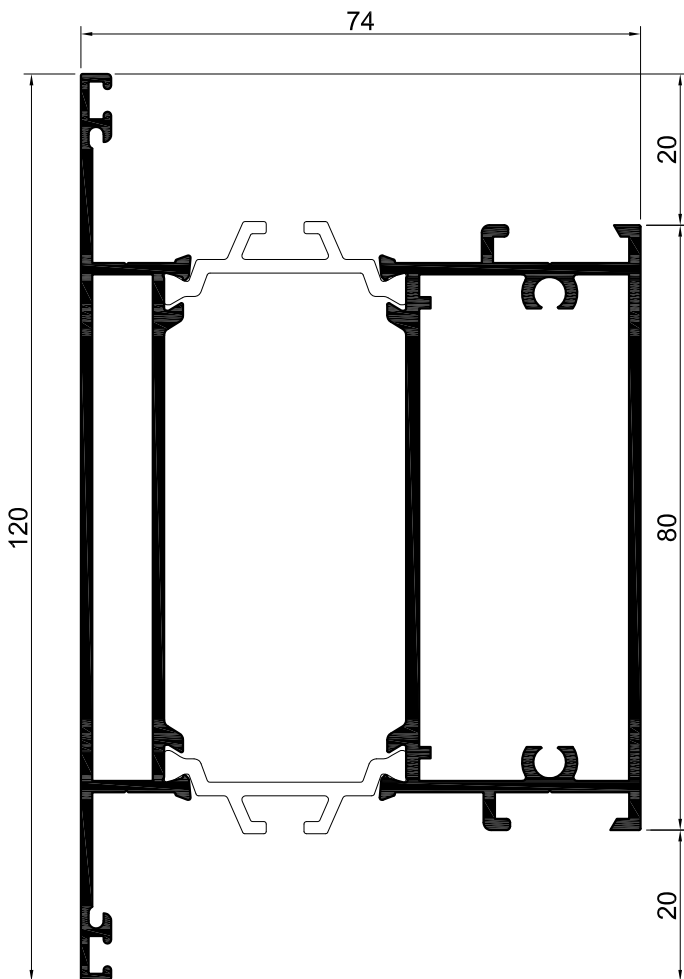

SPW65455
120mm Midrail

120mm Midrail

ALUMINIUM INNER	SPW655
ALUMINIUM OUTER	SPW654
EXTERNAL PERIMETER INNER	284mm
INTERNAL PERIMETER INNER	232mm
EXTERNAL PERIMETER OUTER	325mm
INTERNAL PERIMETER OUTER	150mm
OVERALL EXTERNAL PERIMETER	535mm
POLYAMIDE UPPER	PAW289100
POLYAMIDE LOWER	PAW289100



SPW650-CT66



SPW652-CT58

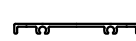

SPW679-CUT ⊗

Ixx ←
Iyy ↑

60.0313cm⁴

66.3946cm⁴

⊗ This shear block not suitable for cruciform arrangements

EPS Inserts

EPS In To Thermal Break	EPS007 + EPS008
EPS Under Glass (Fixed Light Only)	EPS005

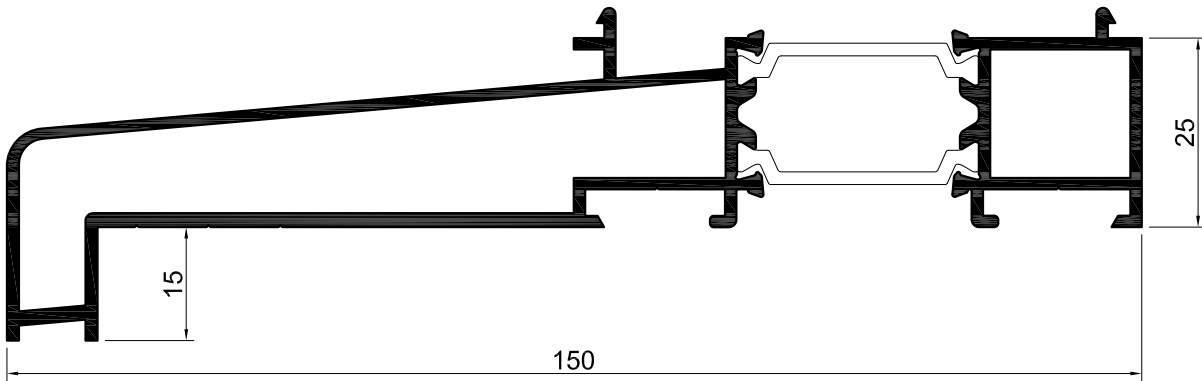

SPW65653
150mm Cill

150mm Cill

ALUMINIUM INNER	SPW653
ALUMINIUM OUTER	SPW656
EXTERNAL PERIMETER INNER	147mm
INTERNAL PERIMETER INNER	71mm
EXTERNAL PERIMETER OUTER	342mm
INTERNAL PERIMETER OUTER	238mm
OVERALL EXTERNAL PERIMETER	460mm
POLYAMIDE UPPER	PAW939700
POLYAMIDE LOWER	PAW939700
END CAPS	SCA201LB (Black) SCA201RB (Black) Or SCA201LW (White) SCA201RW (White)

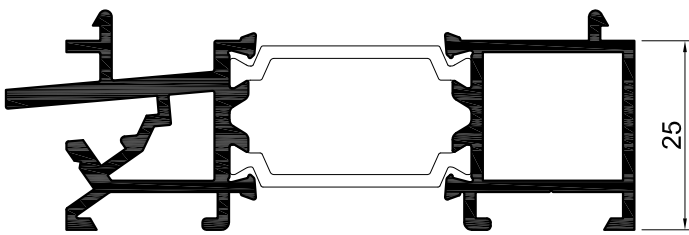

SPW68553
Drainage Cill

Drainage Cill

ALUMINIUM INNER	SPW653
ALUMINIUM OUTER	SPW685
EXTERNAL PERIMETER INNER	147mm
INTERNAL PERIMETER INNER	71mm
EXTERNAL PERIMETER OUTER	165mm
INTERNAL PERIMETER OUTER	48mm
OVERALL EXTERNAL PERIMETER	283mm
POLYAMIDE UPPER	PAW939700
POLYAMIDE LOWER	PAW939700

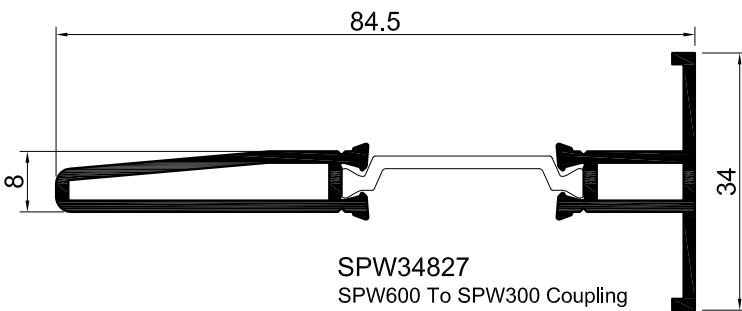

SPW34827
SPW600 To SPW300 Coupling

SPW600 To SPW300 Coupling

ALUMINIUM INNER	SPW327
ALUMINIUM OUTER	SPW348
EXTERNAL PERIMETER INNER	123mm
EXTERNAL PERIMETER OUTER	107mm
INTERNAL PERIMETER INNER	33mm
INTERNAL PERIMETER OUTER	77mm
OVERALL EXTERNAL PERIMETER	250mm
POLYAMIDE	PAW939700
I_{xx} ←	23.1173cm ⁴
I_{yy} ↑	0.7849m ⁴

SPW600e Casement

SPW600e.B.110

Section Identification

04.12

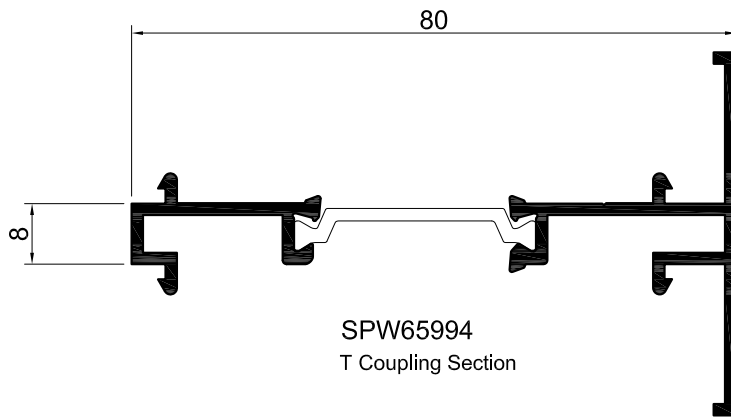

T Coupling Section

ALUMINIUM INNER	SPW694
ALUMINIUM OUTER	SPW659
EXTERNAL PERIMETER INNER	229mm
EXTERNAL PERIMETER OUTER	130mm
OVERALL EXTERNAL PERIMETER	382mm
POLYAMIDE	PAW939700
Ixx ←	22.2960cm ⁴
Iyy ↑	1.8482cm ⁴

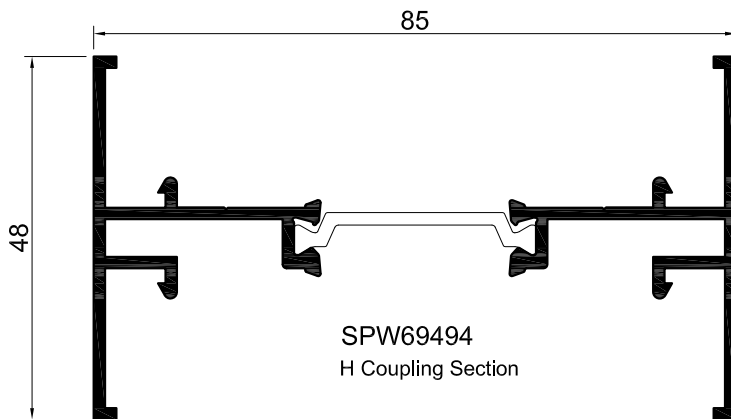

H Coupling Section

ALUMINIUM INNER	SPW694
ALUMINIUM OUTER	SPW694
EXTERNAL PERIMETER INNER	229mm
EXTERNAL PERIMETER OUTER	229mm
OVERALL EXTERNAL PERIMETER	471mm
POLYAMIDE	PAW939700
Ixx ←	40.6309cm ⁴
Iyy ↑	3.4880cm ⁴

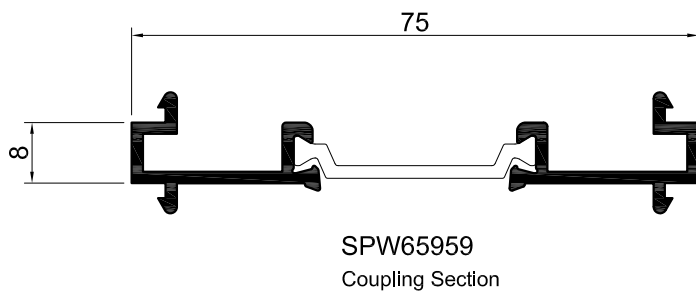

Coupling Section

ALUMINIUM INNER	SPW659
ALUMINIUM OUTER	SPW659
EXTERNAL PERIMETER INNER	130mm
EXTERNAL PERIMETER OUTER	130mm
OVERALL EXTERNAL PERIMETER	270mm
POLYAMIDE	PAW939700
Ixx ←	12.8731cm ⁴
Iyy ↑	0.2103cm ⁴

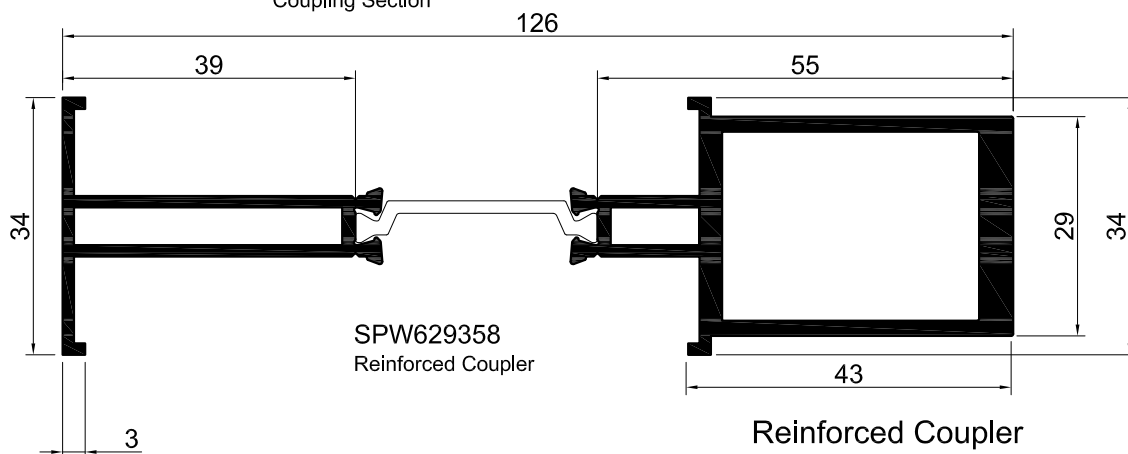

Reinforced Coupler

ALUMINIUM OUTER	SPW629
ALUMINIUM INNER	SPW358
EXTERNAL PERIMETER OUTER	171mm
INTERNAL PERIMETER OUTER	81mm
EXTERNAL PERIMETER INNER	203mm
INTERNAL PERIMETER INNER	118mm
OVERALL EXTERNAL PERIMETER	290mm
POLYAMIDE UPPER	PAW939700
Ixx ←	113.3932cm ⁴
Iyy ↑	5.1255cm ⁴

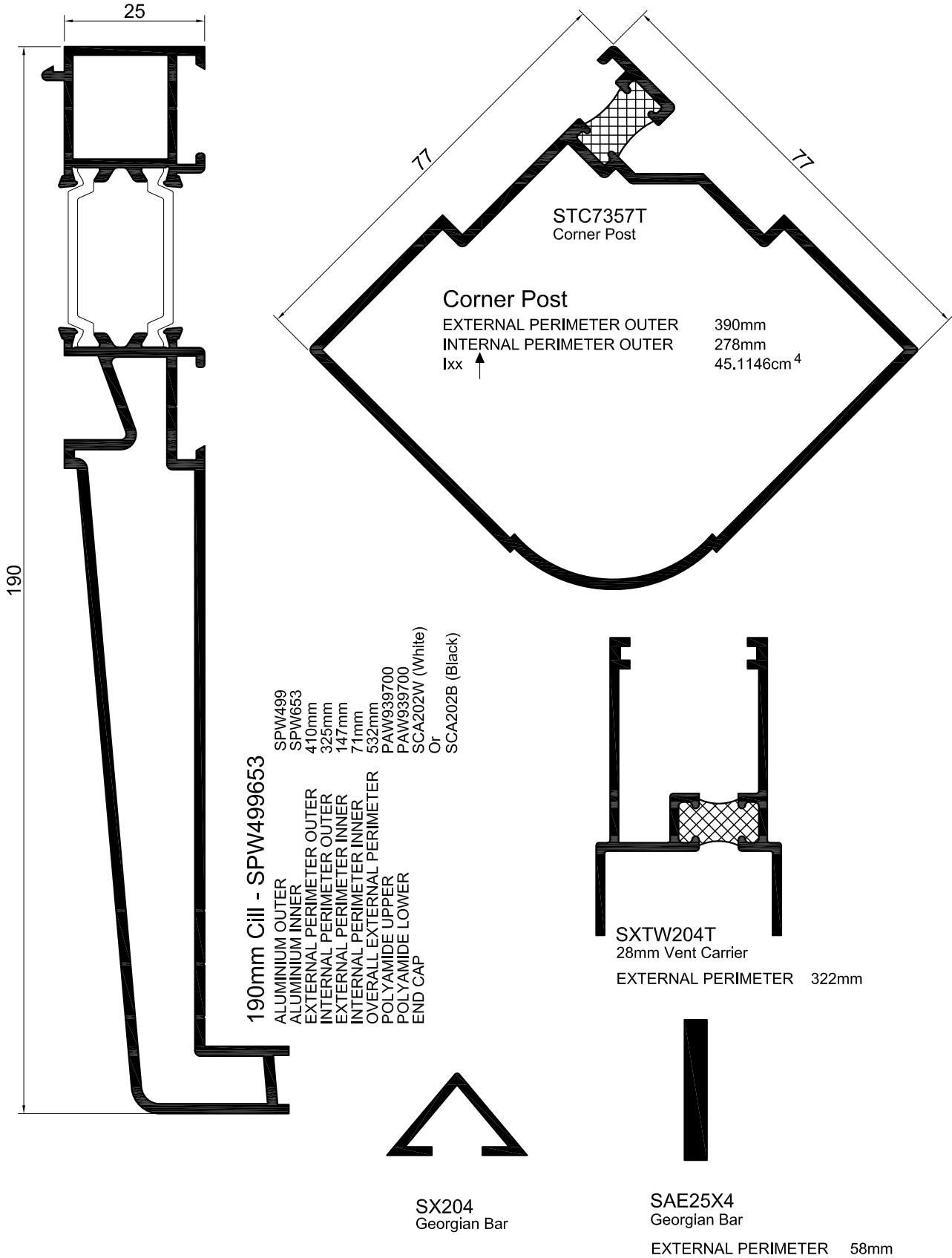

SPW600e Casement

SPW600e.B.112

Section Identification

04.12

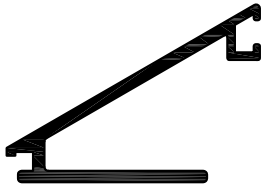

SPW621
28mm External Glazed Bead
EXTERNAL PERIMETER 151mm



SPW688
28mm External Glazed Bead
EXTERNAL PERIMETER 167mm

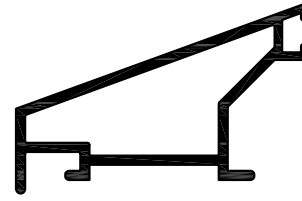

SPW687
28mm External GI Drainage Bead
EXTERNAL PERIMETER 142mm
INTERNAL PERIMETER 86mm

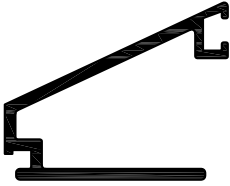

SPW697
32mm External Glazed Bead
EXTERNAL PERIMETER 157mm

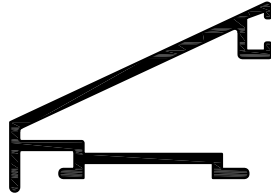

SPW696
32mm External GI Drainage Bead
EXTERNAL PERIMETER 187mm

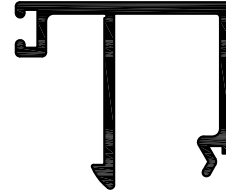

SPW624
32mm Internal Glazed Bead
EXTERNAL PERIMETER 177mm



SW467
28mm Internal Glazed Bead
EXTERNAL PERIMETER 169mm

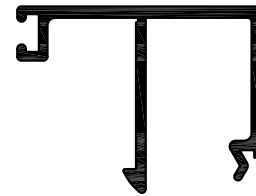

SPW643
28mm Internal Glazed Bead
EXTERNAL PERIMETER 185mm

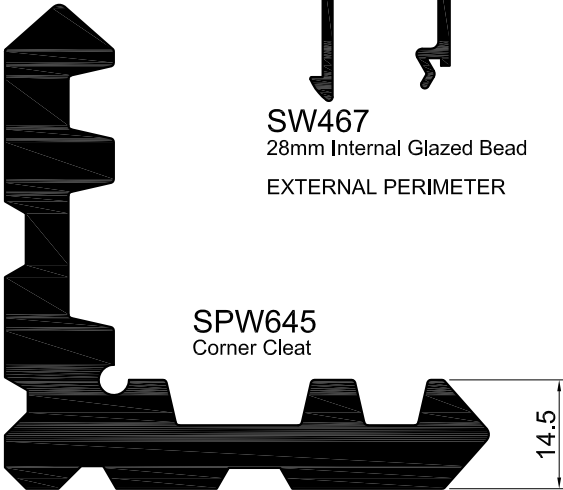

SPW645
Corner Cleat

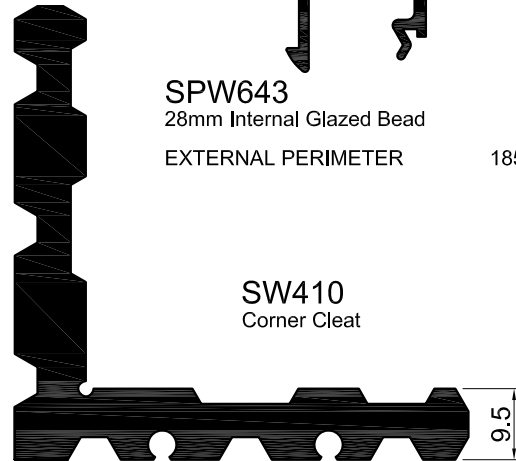

SW410
Corner Cleat

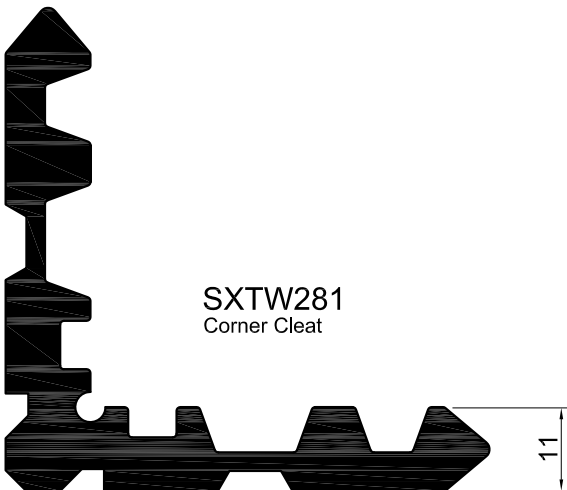

SXTW281
Corner Cleat



SW445
Corner Cleat

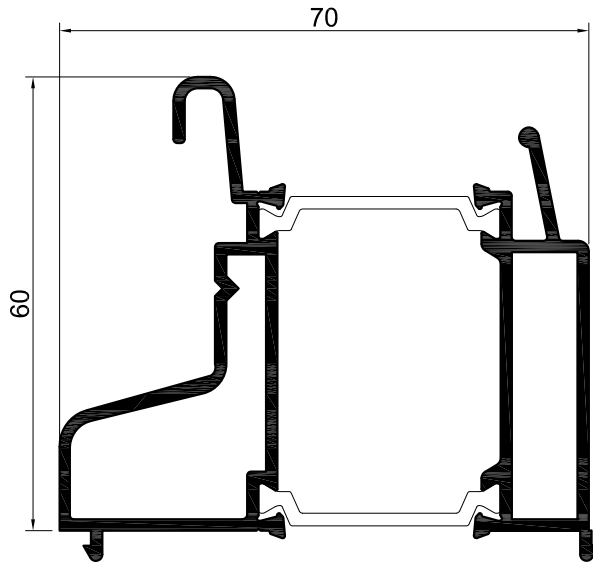

SPW67172
Kingspan
70mm Head Adaptor

Kingspan 70mm Head Adaptor

ALUMINIUM INNER	SPW672
ALUMINIUM OUTER	SPW671
EXTERNAL PERIMETER INNER	212mm
INTERNAL PERIMETER INNER	108mm
EXTERNAL PERIMETER OUTER	231mm
INTERNAL PERIMETER OUTER	112mm
OVERALL EXTERNAL PERIMETER	344mm
POLYAMIDE UPPER	PAW939700
POLYAMIDE LOWER	PAW939700

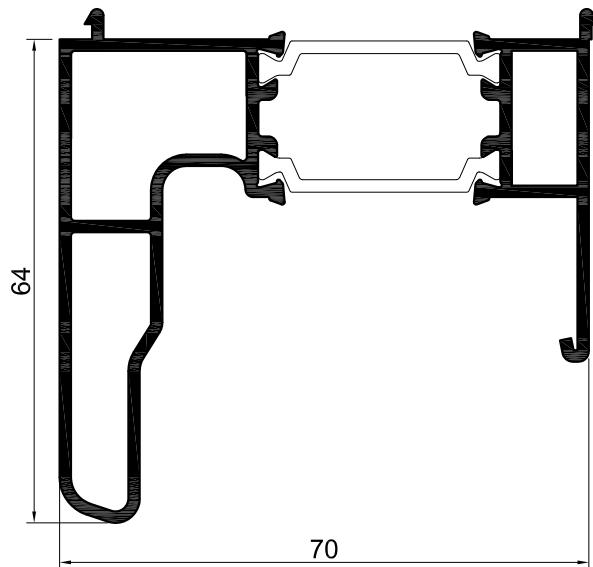

SPW67475
Kingspan
70mm Cill/Jamb Adaptor

Kingspan 70mm Cill/Jamb Adaptor

ALUMINIUM INNER	SPW675
ALUMINIUM OUTER	SPW674
EXTERNAL PERIMETER INNER	152mm
INTERNAL PERIMETER INNER	51mm
EXTERNAL PERIMETER OUTER	215mm
INTERNAL PERIMETER OUTER	181mm
OVERALL EXTERNAL PERIMETER	347mm
POLYAMIDE UPPER	PAW939700
POLYAMIDE LOWER	PAW939700

SPW600e Casement

SPW600e.B.114

Section Identification 80mm Kingspan Adaptors

04.12

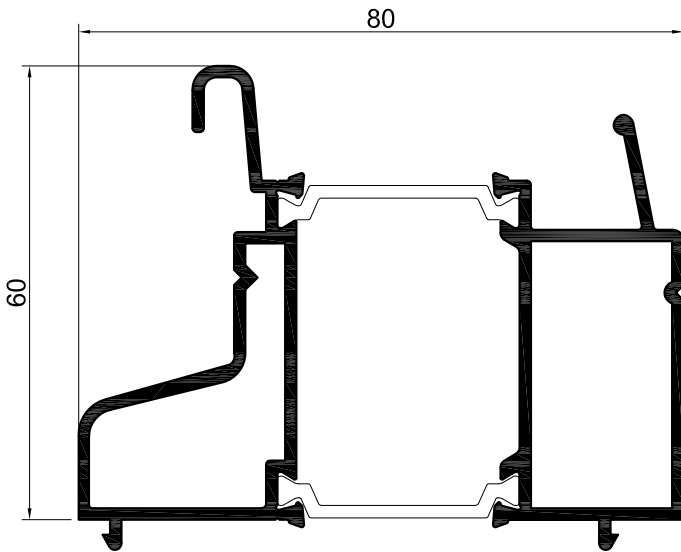

SPW67173
Kingspan
80mm Head Adaptor

Kingspan 80mm Head Adaptor

ALUMINIUM INNER	SPW673
ALUMINIUM OUTER	SPW671
EXTERNAL PERIMETER INNER	203mm
INTERNAL PERIMETER INNER	108mm
EXTERNAL PERIMETER OUTER	231mm
INTERNAL PERIMETER OUTER	115mm
OVERALL EXTERNAL PERIMETER	363mm
POLYAMIDE UPPER	PAW939700
POLYAMIDE LOWER	PAW939700

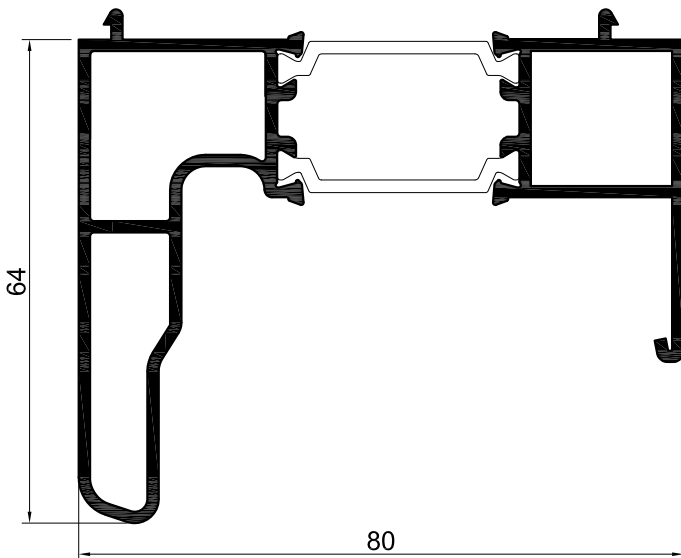

SPW67476
Kingspan
80mm Cill/Jamb Adaptor

Kingspan 80mm Cill/Jamb Adaptor

ALUMINIUM INNER	SPW676
ALUMINIUM OUTER	SPW674
EXTERNAL PERIMETER INNER	171mm
INTERNAL PERIMETER INNER	71mm
EXTERNAL PERIMETER OUTER	215mm
INTERNAL PERIMETER OUTER	181mm
OVERALL EXTERNAL PERIMETER	377mm
POLYAMIDE UPPER	PAW939700
POLYAMIDE LOWER	PAW939700

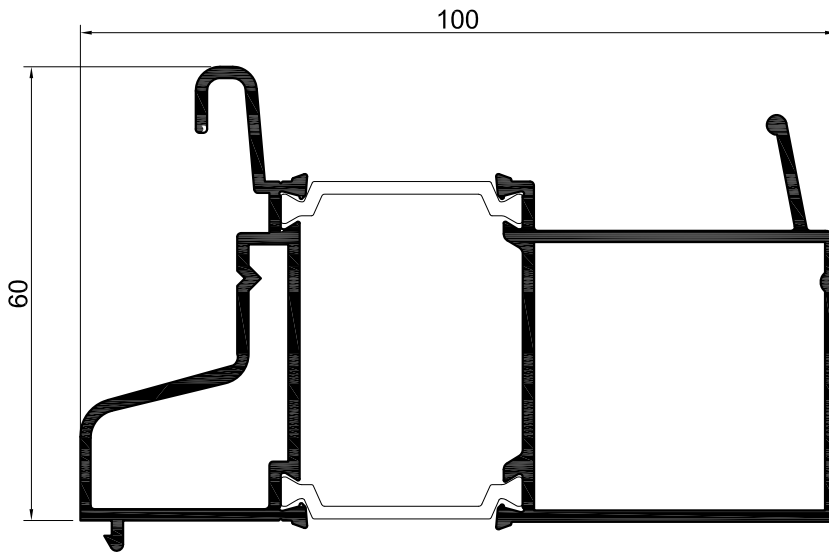

Kingspan 100mm Head Adaptor

ALUMINIUM INNER	SPW382
ALUMINIUM OUTER	SPW671
EXTERNAL PERIMETER INNER	232mm
INTERNAL PERIMETER INNER	148mm
EXTERNAL PERIMETER OUTER	231mm
INTERNAL PERIMETER OUTER	115mm
OVERALL EXTERNAL PERIMETER	403mm
POLYAMIDE UPPER	PAW939700
POLYAMIDE LOWER	PAW939700

SPW671382
Kingspan
100mm Head Adaptor

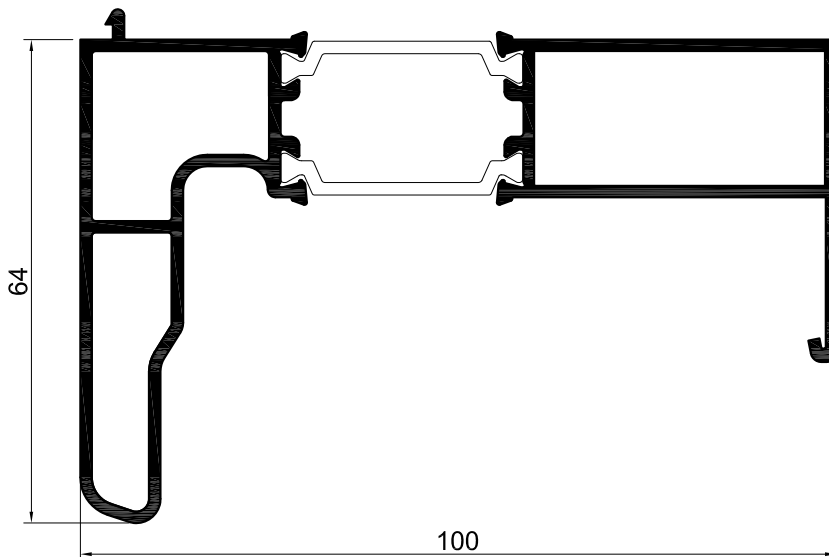

Kingspan 100mm Cill/Jamb Adaptor

ALUMINIUM INNER	SPW381
ALUMINIUM OUTER	SPW674
EXTERNAL PERIMETER INNER	202mm
INTERNAL PERIMETER INNER	112mm
EXTERNAL PERIMETER OUTER	215mm
INTERNAL PERIMETER OUTER	181mm
OVERALL EXTERNAL PERIMETER	417mm
POLYAMIDE UPPER	PAW939700
POLYAMIDE LOWER	PAW939700

SPW674381
Kingspan
100mm Cill/Jamb Adaptor

SPW600e Casement

Blank

SPW600e.B.116

04.12

This Page is Intentionally Left Blank

SPW600e.C.101

SPW600e Casement

04.12

Accessories

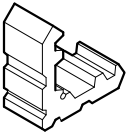

SPW645CT28
Cut Corner Cleat

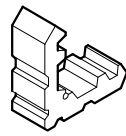

SPW645CT24
Cut Corner Cleat

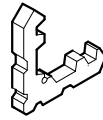

SPW645CT8
Cut Corner Cleat

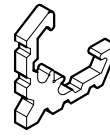

SW445CT8
Cut Corner Cleat

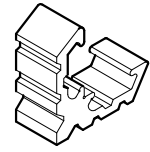

SW445CT28
Cut Corner Cleat

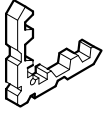

SXTW281CT8
Cut Corner Cleat

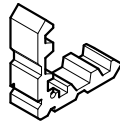

SXTW281CT18
Cut Corner Cleat



SPW650CT21
Shear Block

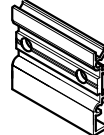

SPW650CT66
Shear Block



SPW650CT30
Shear Block

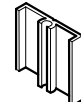

SPW678CUT
Shear Block

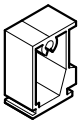

SPW651CT21
Shear Block

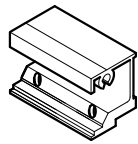

SPW352CT58
Shear Block

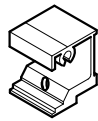

SPW352CT31
Shear Block

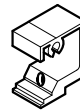

SPW352CT21
Shear Block



SPW677CUT
Shear Block

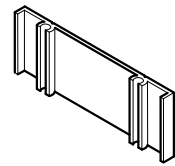

SPW679CUT
Shear Block

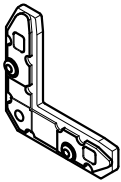

SH881A
Corner Cleat

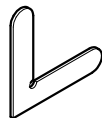

SW4CH7
7mm Corner Chevron

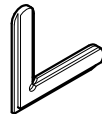

CHEV7P
7mm Corner Chevron
Plastic



SW4CH15
15mm Corner Chevron

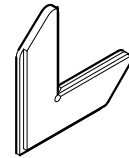

CHEV15P
15mm Corner Chevron
Plastic



SWTP
2Dia.x12Lg
Celloc Pin



SFSGM37
M5x10Lg Grub
Screw Cone Point



SFSPM36
M4x5Lg M/C Screw



SWWBS
Weatherbar Stud
Rivet for SXTW216



SFSPS04
#10x12Lg P/Hd
Self Tapping Screw



SFSPS05
#10x19Lg.
Self Tapping Screw



SFSPS28
#8x12Lg P/Hd
Self Tapping Screw



SFSPS33
#8x19Lg P/Hd
Self Tapping Screw



SFSPS41
#8x3/8" Lg P/Hd
Self Tapping Screw



SFSCS03
#8x12Lg Csk
Self Tapping Screw



SFSCS07
#8x15Lg.
Self Tapping Screw



SFSCS29
#8x40Lg Csk
Self Tapping Screw



SFSCS30
#8x25Lg Csk
Self Tapping Screw



SFSCS850
#8x50Lg. C/SK.



SFSCS0512
M5x12Lg Csk M/C Screw

SPW600e Casement

SPW600e.C.102

Accessories

06.13

ESPAGNOLETTE LOCKING

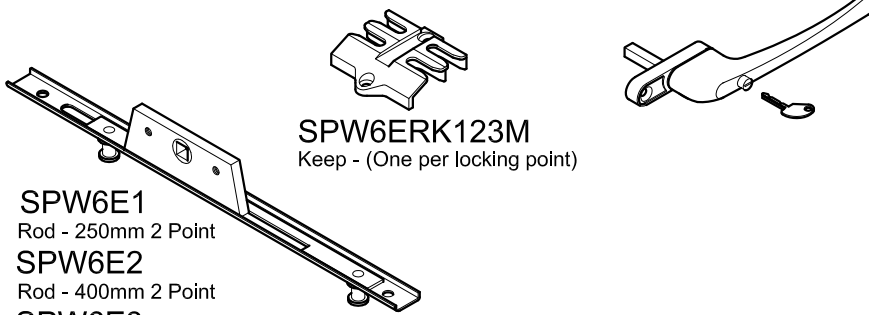

SPW6ERK123M
Keep - (One per locking point)

INLINEBS & SPIN20MM
Brushed Stainless Handle & 20mm Spindle

INLINEW & SPIN20MM
White Handle & 20mm Spindle

INLINEB & SPIN20MM
Black Handle & 20mm Spindle

INLINEPC & SPIN20MM
Polished Chrome Handle & 20mm Spindle

- SPW6E1**
Rod - 250mm 2 Point
- SPW6E2**
Rod - 400mm 2 Point
- SPW6E3**
Rod - 600mm 2 Point
- SPW6E4**
Rod - 800mm 2 Point
- SPW6E5**
Rod - 1000mm 3 Point

SHOOTBOLT ESPAGNOLETTE LOCKING

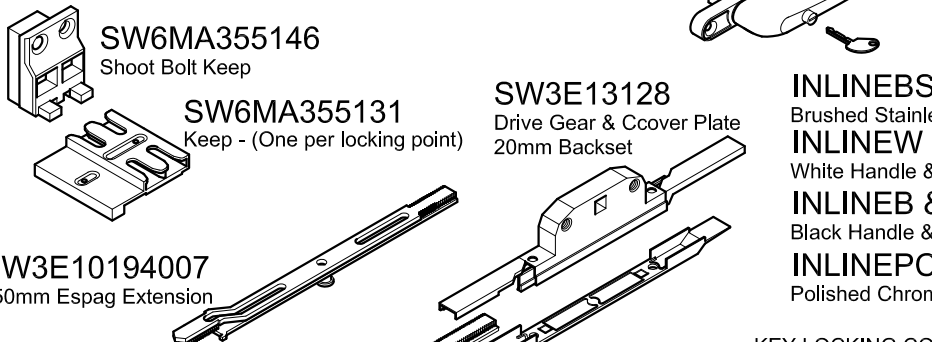

SW6MA355146
Shoot Bolt Keep

SW6MA355131
Keep - (One per locking point)

SW3E13128
Drive Gear & Ccover Plate
20mm Backset

SW3E10194007
250mm Espag Extension

INLINEBS & SPIN9MM
Brushed Stainless Handle & 9mm Spindle

INLINEW & SPIN9MM
White Handle & 9mm Spindle

INLINEB & SPIN9MM
Black Handle & 9mm Spindle

INLINEPC & SPIN9MM
Polished Chrome Handle & 9mm Spindle

KEY LOCKING COCKSPUR HANDLE

- SW9LLS** 9.5mm B/Set LH Silver
- SW9LLB** 9.5mm B/Set LH Black
- SW9LLW** 9.5mm B/Set LH White
- SW9LLG** 9.5mm B/Set LH Gold
- SW9LRS** 9.5mm B/Set RH Silver
- SW9LRB** 9.5mm B/Set RH Black
- SW9LRW** 9.5mm B/Set RH White
- SW9LRG** 9.5mm B/Set RH Gold

- SW3E28215**
Espag Arm 320-380
- SW3E28610**
Espag Arm 381-800
- SW3E28612**
Espag Arm 801-1100
- SW3E28614**
Espag Arm 1101-1400

HCMA356366SC
Sash Hinge Protector

SWHW3W
Handle Wedge White 3mm

SWHW3B
Handle Wedge Black 3mm

HCMA353309SC
Frame Hinge Protector

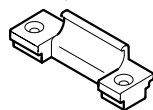

SW2PB
2mm Black Pack For SW9L

SW2PW
2mm White Pack For SW9L

HCMA359086SC
Stabilizer Stay

SWST22
Top Hung 22" Stay

SWSTS16
Side Hung 16" Stay

- SWFS10**
Top Hung 10" Stay
- SWFS12SH**
Side Hung 12" Stay
- SWFS12**
Top Hung 12" Stay
- SWFS16**
Top Hung 16" Stay
- SWFS20**
Top Hung 20" Stay
- SWFS24**
Top Hung 24" Stay
- SWFS24HD**
Top Hung HD 24" Stay
- SWH-EDSE12**
Side Hung Egress 12" Stay

- SW4FS08**
Top Hung 8" Stay
- SW4FS10**
Top Hung 10" Stay
- SW4FS12SH**
Side Hung 12" Stay
- SW4FS12**
Top Hung 12" Stay
- SW4FS16**
Top Hung 16" Stay
- SW4FS16SHD**
Side Hung 16" Stay
- SW4FS20**
Top Hung 20" Stay
- SW4FS24**
Top Hung 24" Stay

16mm Stack Height Securistyle "Sterling" Friction Stays

13mm Stack Height Securistyle "Defender" High Lift Friction Stays
Use With SPW6003002 Sash Only

16mm Stack Height Securistyle "Defender" High Lift Friction Stays

Check Hardware Suitability When Using Heavy Glazing Panels

SPW600e.C.103

10.13

SPW600e Casement

Accessories

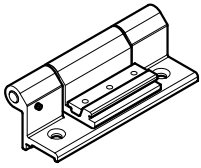

SPW6BUTTOOUTM
Outward Opening Hinge - Mill
SPW6BUTTOOUTN
Outward Opening Hinge - Natural
SPW6BUTTOOUTP
Outward Opening Hinge - Powder Coated

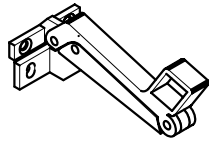

PA11307
Folding Opener SAA

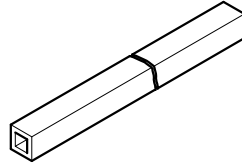

PA25032
Coupling Bar @ 850mm SAA
PA25042
Coupling Bar @ 1000mm SAA

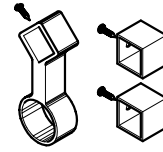

PA25152
Tandem Eye SAA,
End Caps and Screws

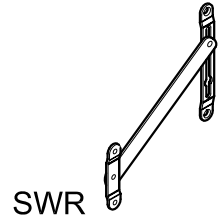

SWR
Window Restrictor SAA

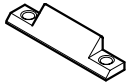

SP300119W
Locking Wedge White
SP300121B
Locking Wedge Black

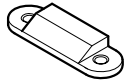

SP400101W
Run-up Block White
SP400103B
Run-up Block Black



SW4D
Drain Hole Cover Black
SW4DW
Drain Hole Cover White

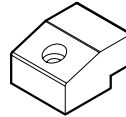

SPWSRB
Run-up Block White
For Espag Vent

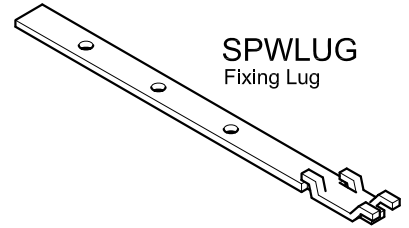

SPWLUG
Fixing Lug

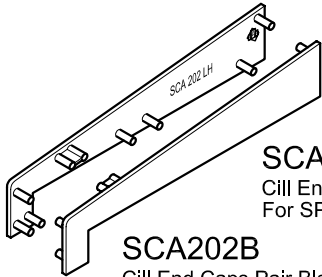

SCA202W
Cill End Caps Pair White
For SPW499693

SCA202B
Cill End Caps Pair Black
For SPW499693



SCA201RB
Cill End Cap RH Black

SCA201LB
Cill End Cap LH Black

SCA201RW
Cill End Cap RH White

SCA201LW
Cill End Cap LH White
For SPW65653

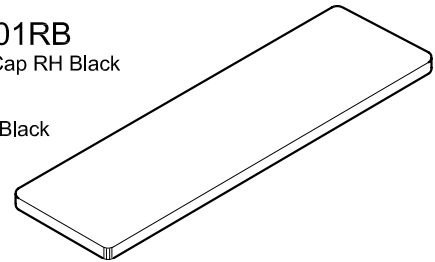

32mm DG Glass Packs

SGP32x2mm 32mm x 100mm DG Glass Packer @ 2mm thick, Black
SGP32x5mm 32mm x 100mm DG Glass Packer @ 5mm thick, Blue

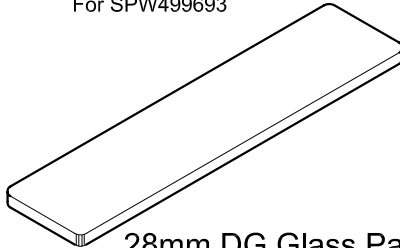

28mm DG Glass Packs

SGP28x1mm 28mm x 100mm DG Glass Packer @ 1mm thick, Green
SGP28x2mm 28mm x 100mm DG Glass Packer @ 2mm thick, Black
SGP28x3mm 28mm x 100mm DG Glass Packer @ 3mm thick, White
SGP28x4mm 28mm x 100mm DG Glass Packer @ 4mm thick, Grey
SGP28x5mm 28mm x 100mm DG Glass Packer @ 5mm thick, Blue
SGP28x6mm 28mm x 100mm DG Glass Packer @ 6mm thick, Red

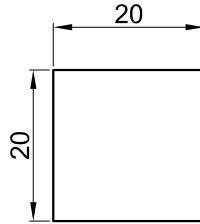

EPS008
20mm x 20mm
Foam Insert

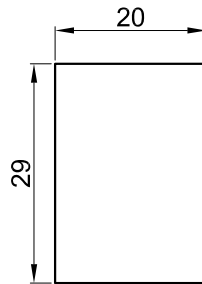

EPS001
20mm x 29mm
Foam Insert

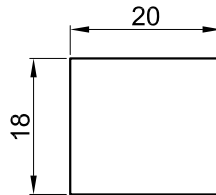

EPS003
20mm x 18mm
Foam Insert

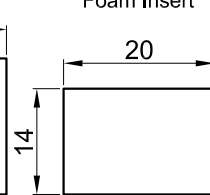

EPS004
20mm x 14mm
Foam Insert

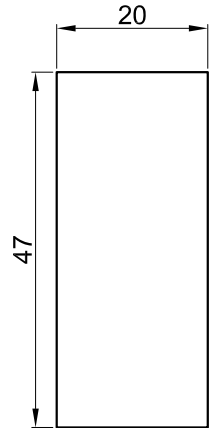

EPS007
20mm x 47mm
Foam Insert

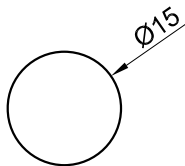

EPS005
Ø15 Foam Strip

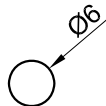

EPS006
Ø6 Foam Strip

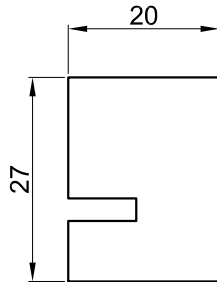

EPS002
20mm x 27mm
Foam Insert

SPW600e Casement

SPW600e.C.104

Accessories - Gaskets & Seals

09.14

Wedge Gaskets

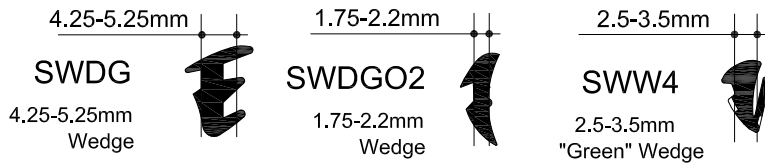

Captive Gasket

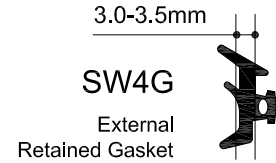

Plant on Georgian Bar

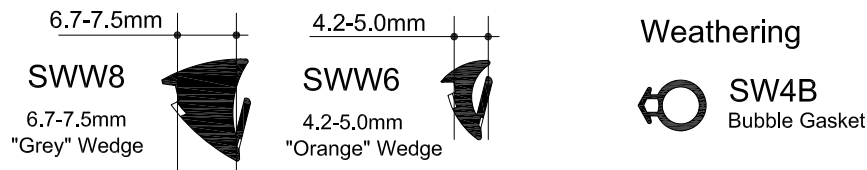

SGT2X25MM
25mm x 2mm
Double Sided Tape
FOR SAE25X4

NOTE: SIZES ARE NOMINAL. WEDGE GASKET MAY NEED TO BE ALTERED TO ACCOMODATE TOLERANCE IN EXTRUSION & GLASS UNITS

'Glazed Out' SPW600 Outer Frames and Vents

Glass Thickness(mm)	Glazing Space	Bead Reference	Wedge Internal	Captive External
28.0	36.0	SPW621	SWDG	SW4G
* 28.0	36.0	SPW687 & SPW688	SWDG	SW4G
* 32.0	40.0	SPW696 & SPW697	SWDG	SW4G

* NOTE:-THESE SIZES INCLUDE DRAINAGE BEADS

'Glazed In' SPW600 Outer Frames and Vents

Glass Thickness(mm)	Glazing Space	Bead Reference	Wedge Internal	Captive External
28.0	36.0	SPW643	SWDG	SW4G
30.0	38.5	†SW463	SWDG	SW4G
32.0	40.0	SPW624	SWDG	SW4G
36.0	44.0	†SW467	SWDG	SW4G
44.0	52.0	†SW462	SWDG	SW4G
48.0	56.0	†SW461	SWDG	SW4G
52.0	60.0	†SW464	SWDG	SW4G
56.0	64.0	†SW476	SWDG	SW4G

† Non Standard Beads May Not Be Available - Check With SAS
Check Hardware Suitability When Using Heavy Glazing Panels

SPW600e.D.101

04.12

SPW600e Casement

Deductions - Frame And Glass

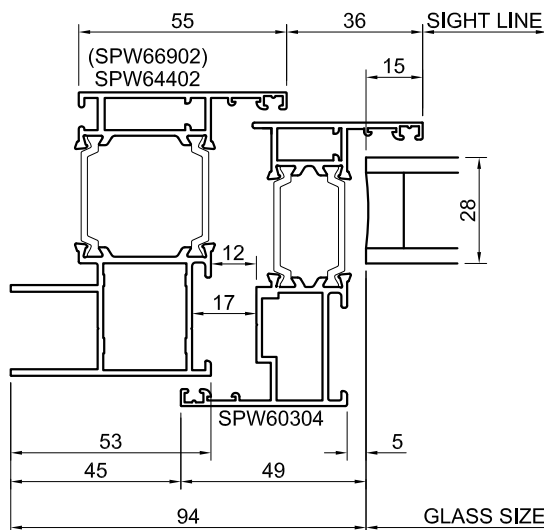
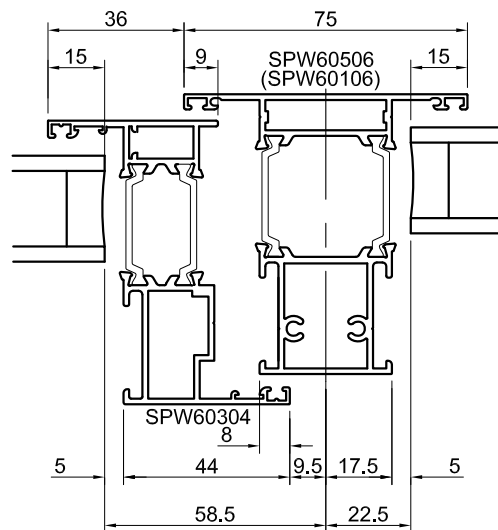
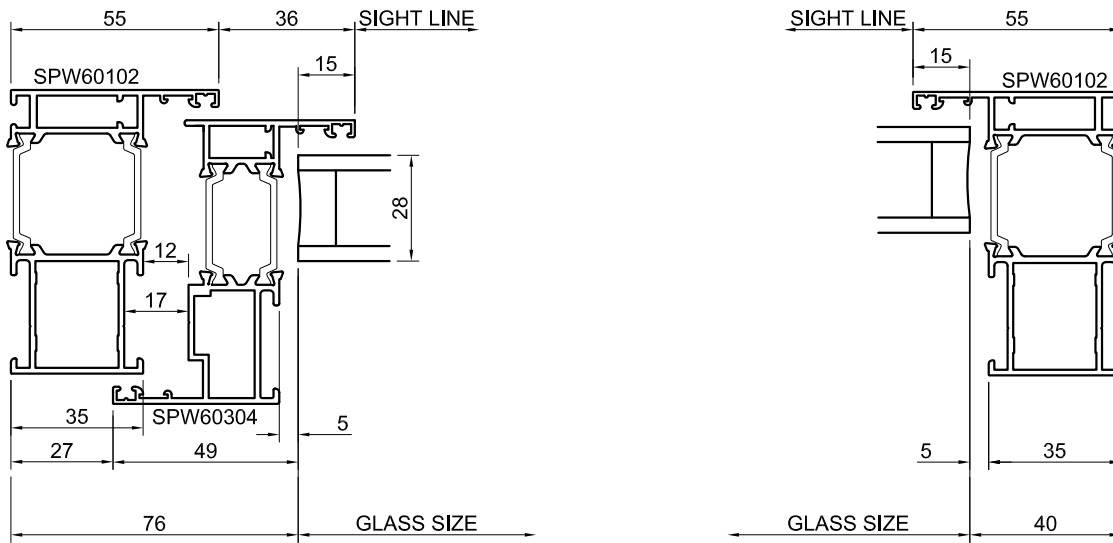

SPW600e Casement

SPW600e.D.102

Deductions - Frame and Glass

04.12

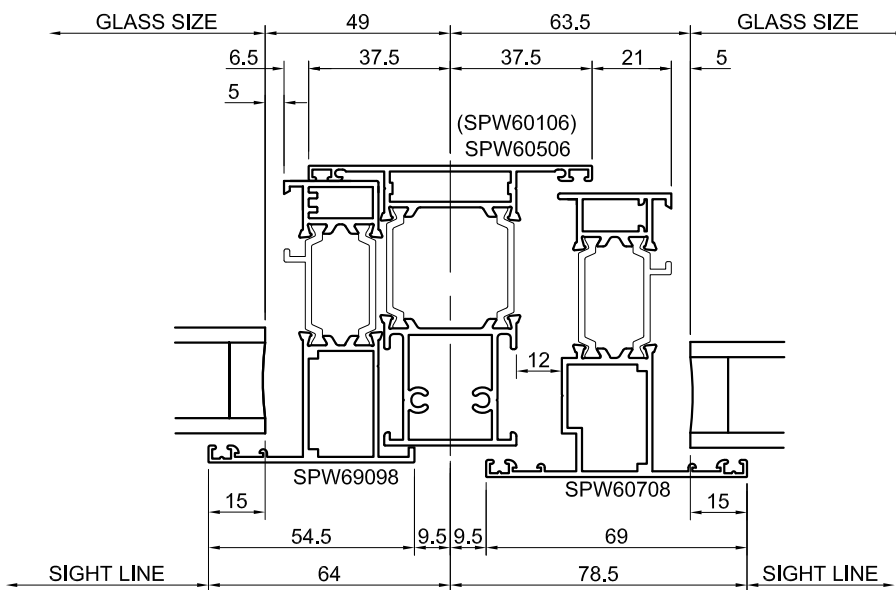
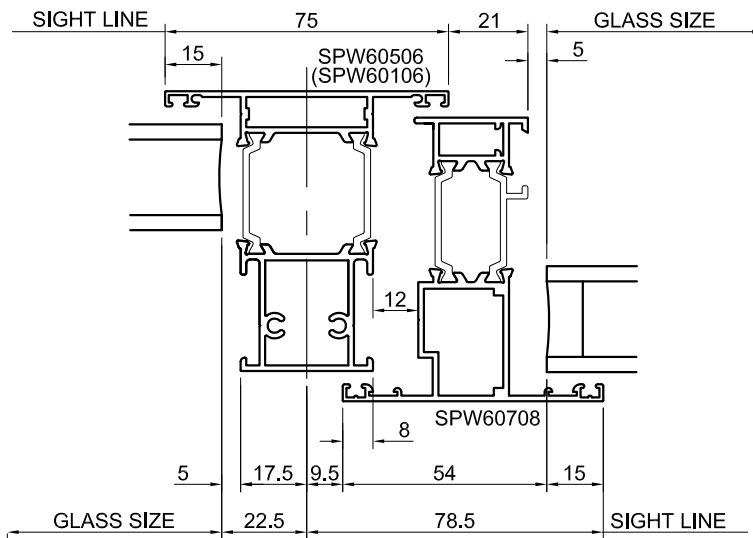
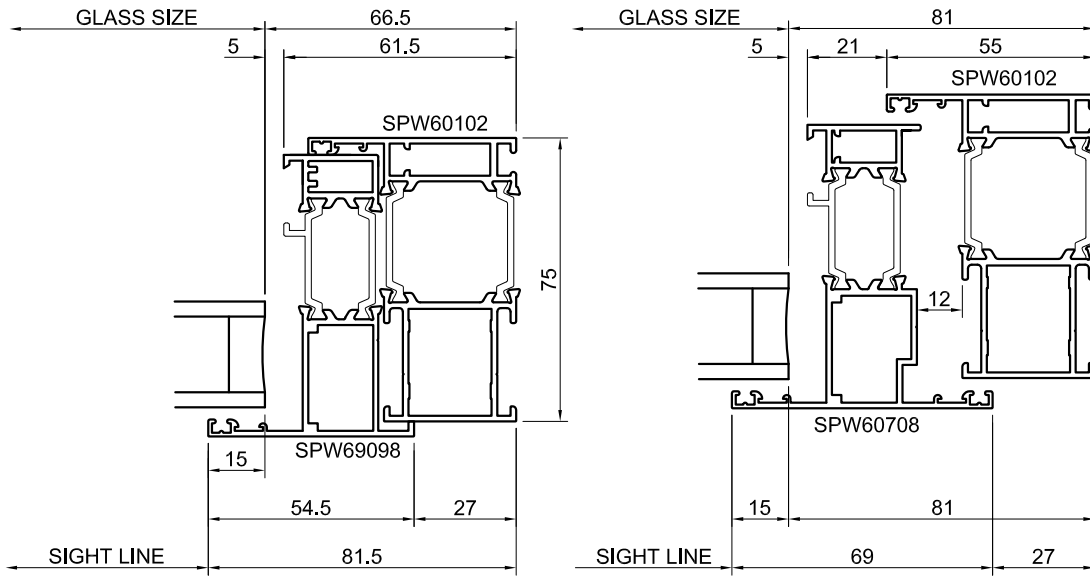

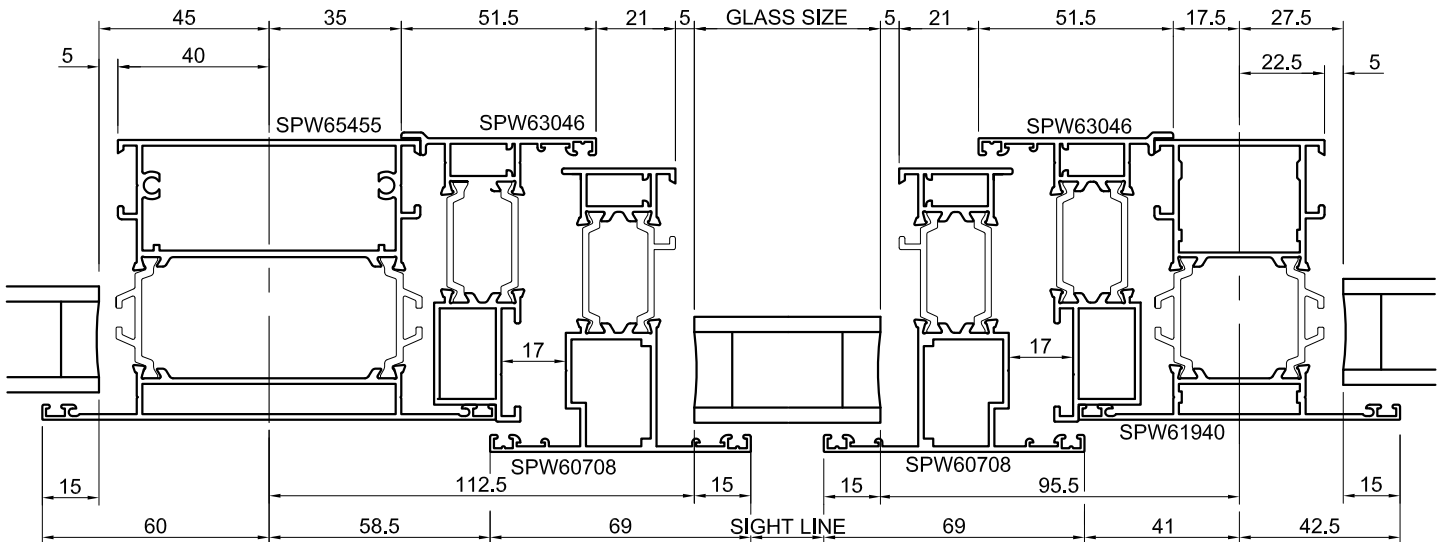
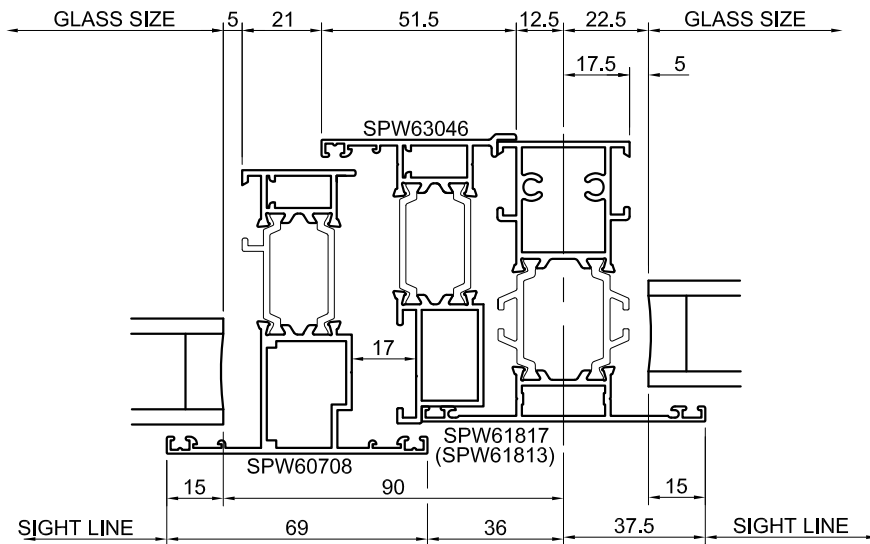
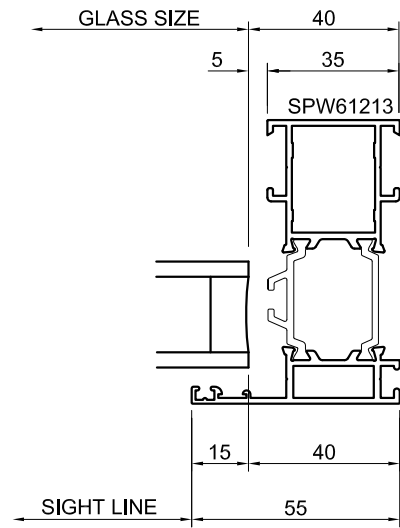
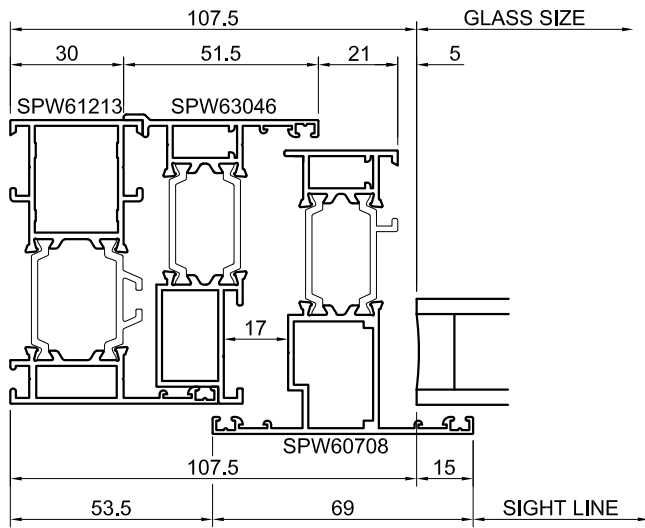

SPW600e Casement

SPW600e.D.104

Deductions- Frame And Glass

04.12

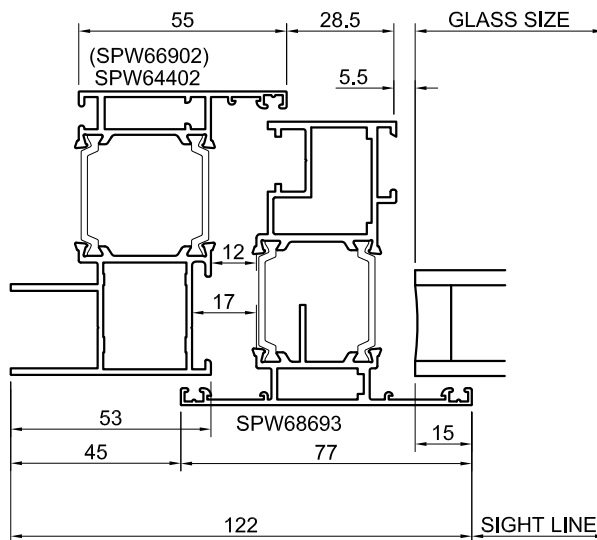
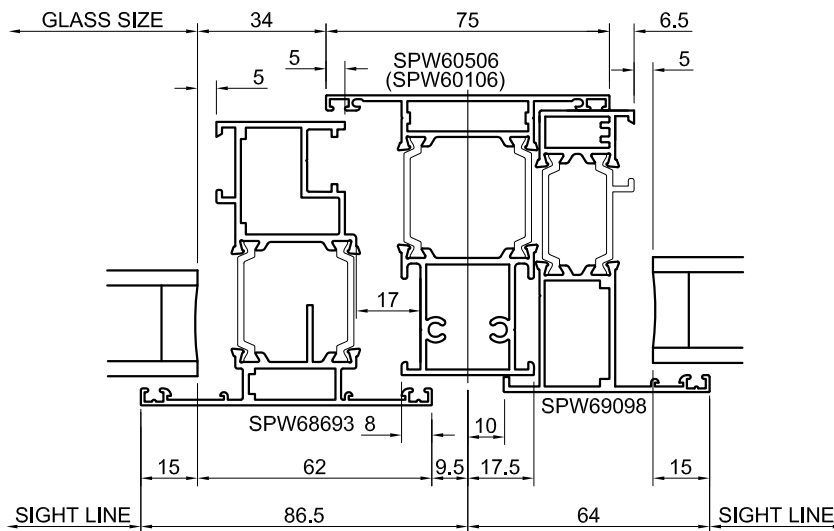
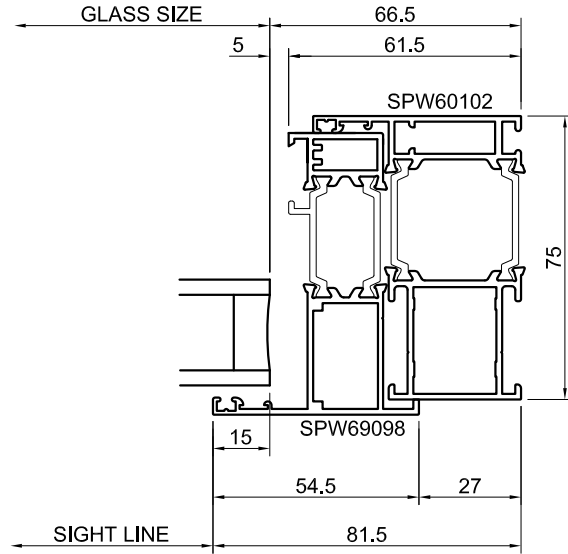
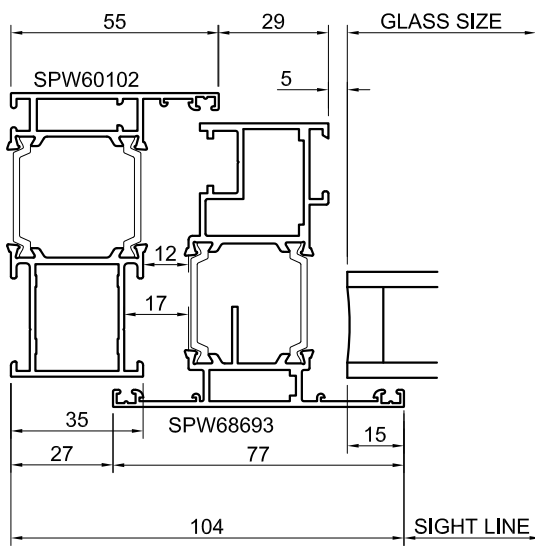

SPW600e.D.105

04.12

SPW600e Casement

Deductions - Frame and Glass

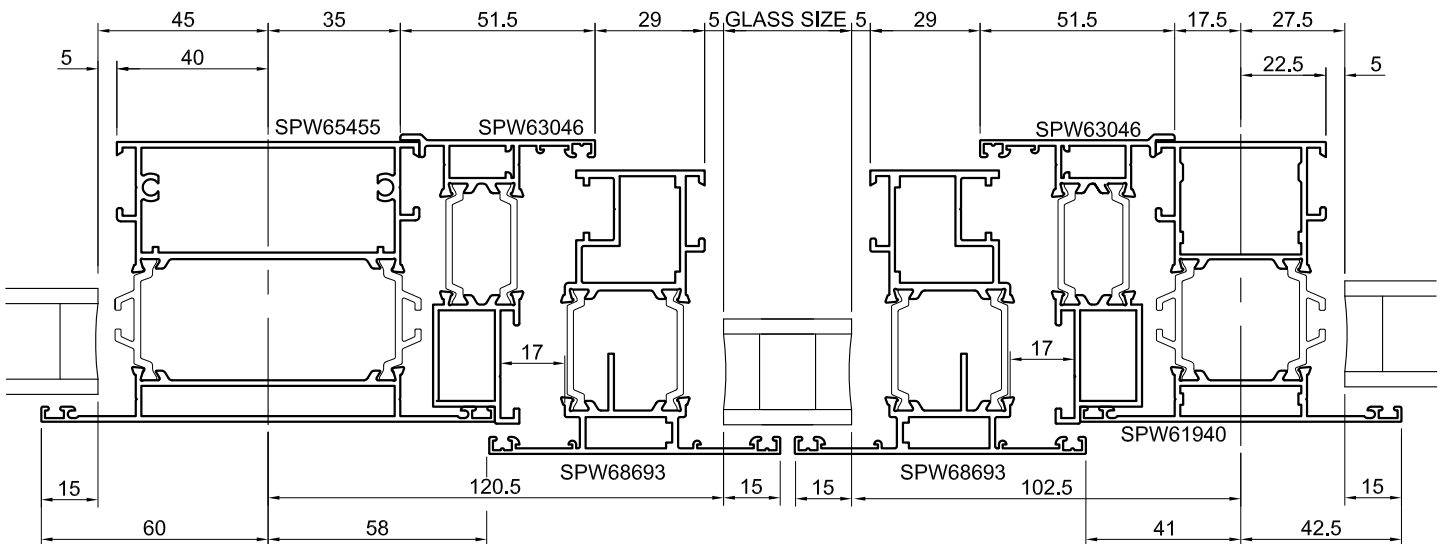
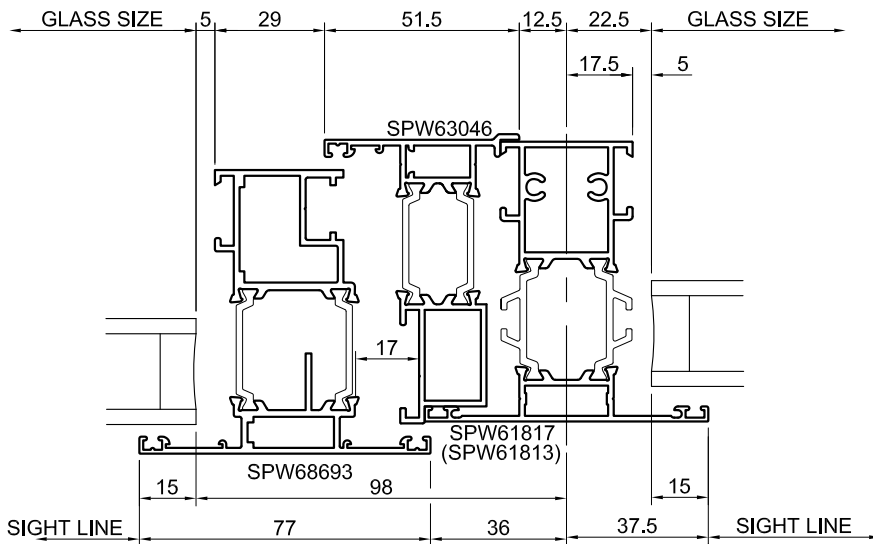
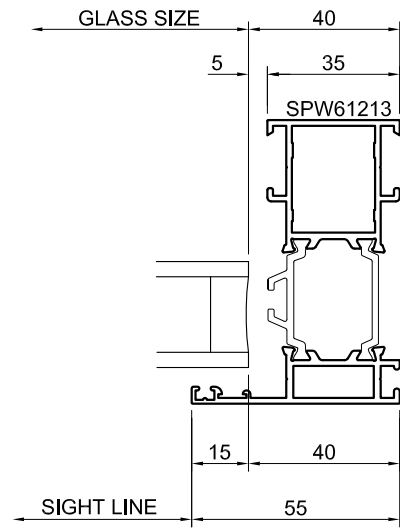
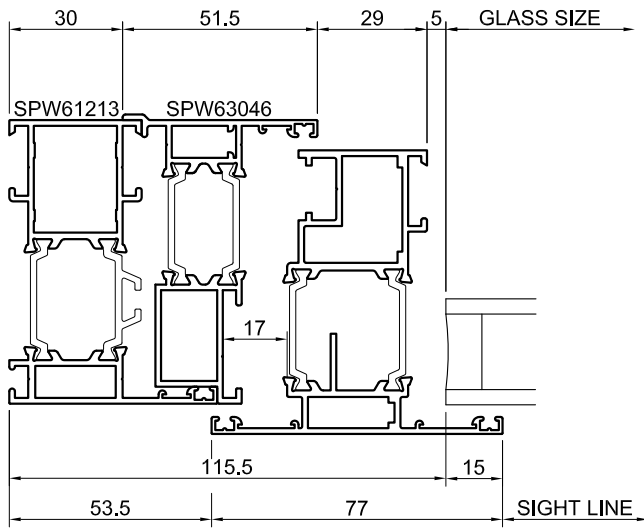

SPW600e Casement

Deductions - Frame and Glass

SPW600e.D.106

04.12

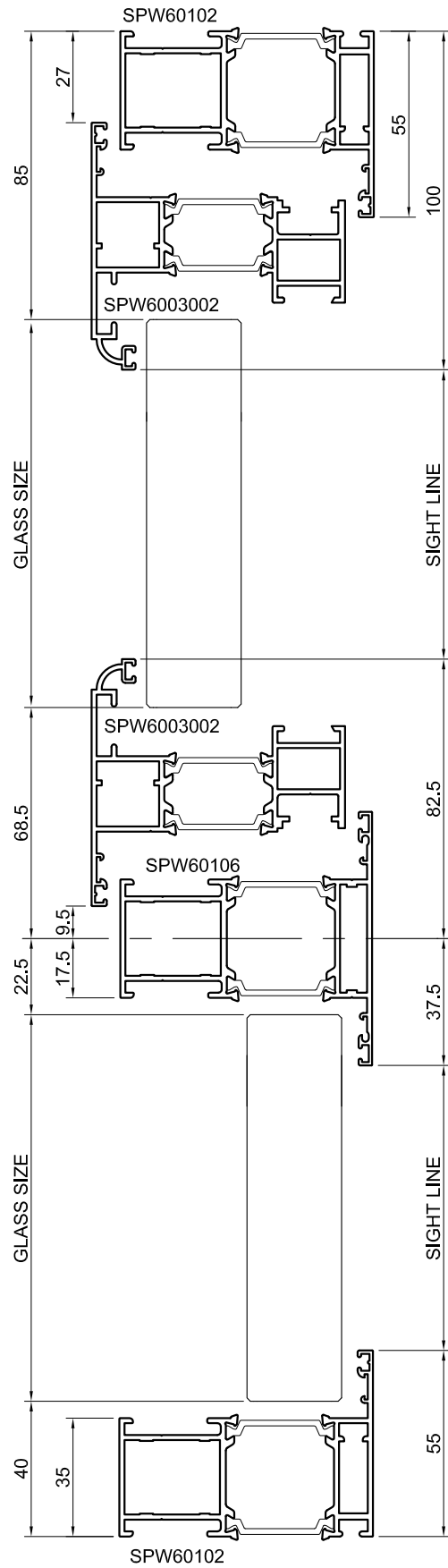
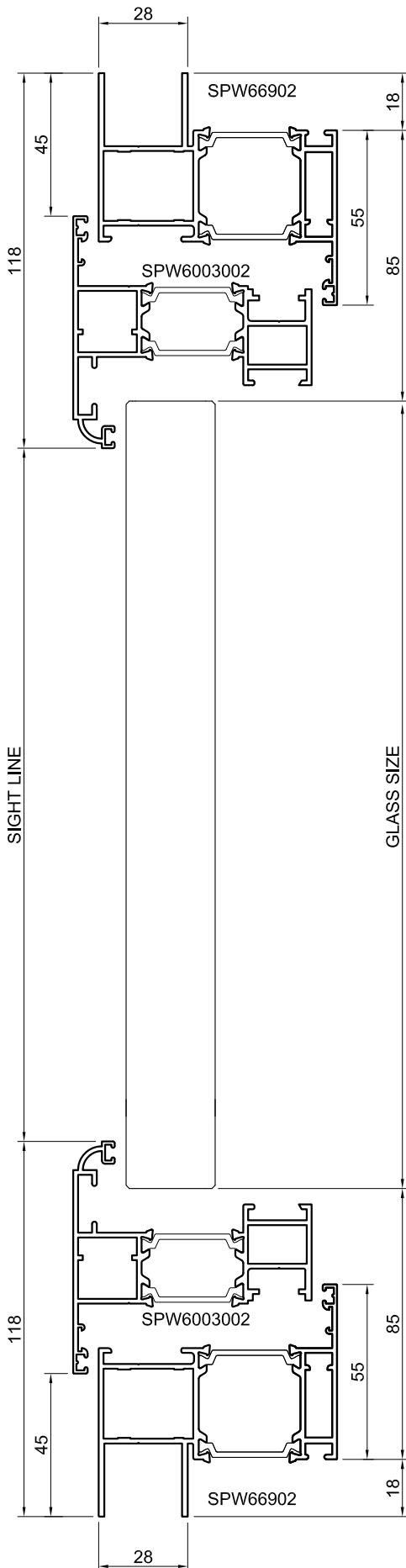

SPW600e.D.107

04.12

SPW600e Casement

Deductions - Frame and Glass

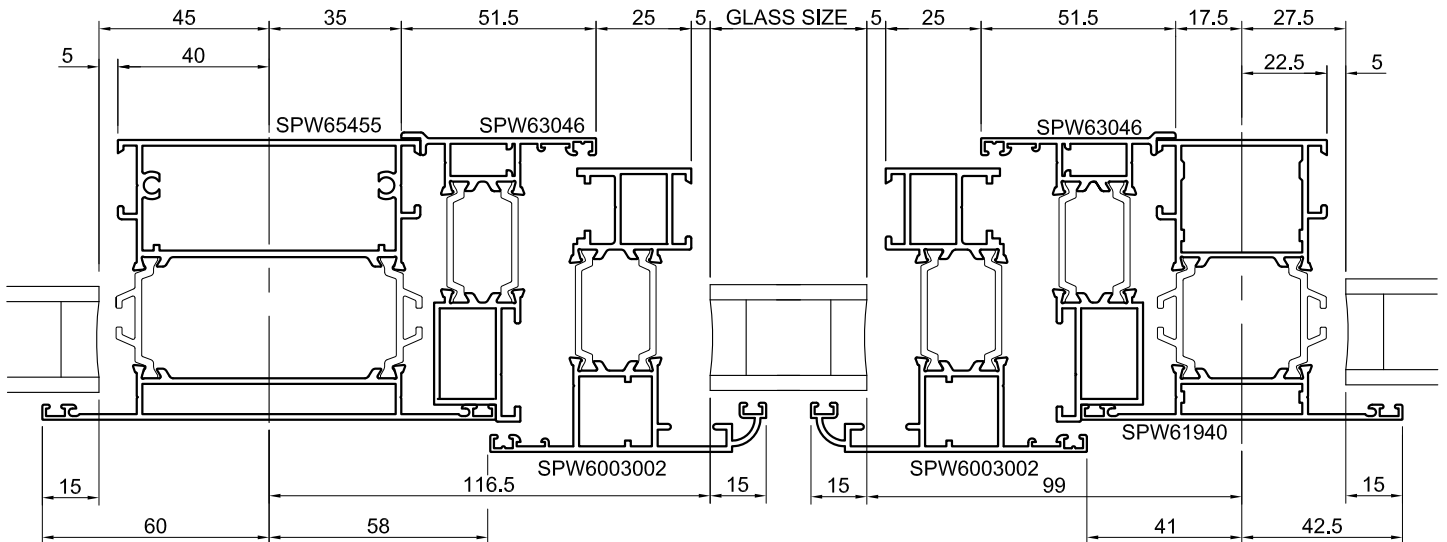
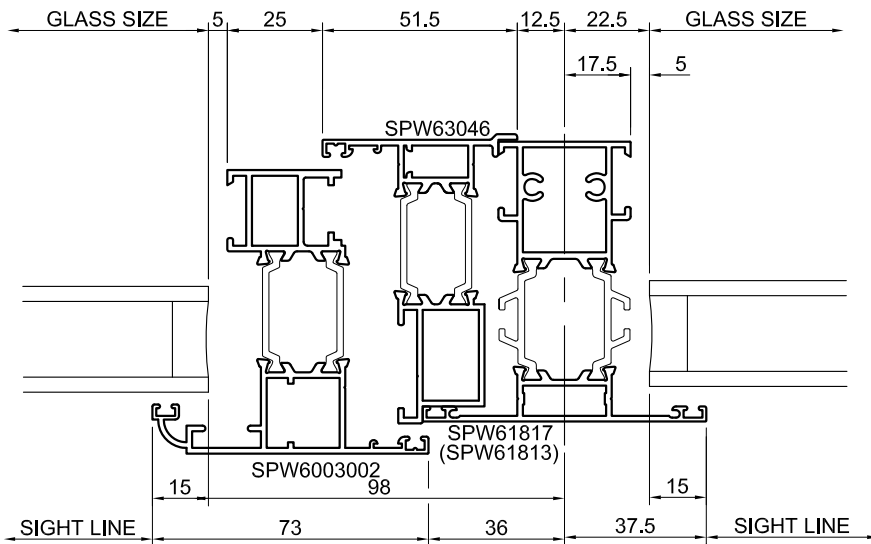
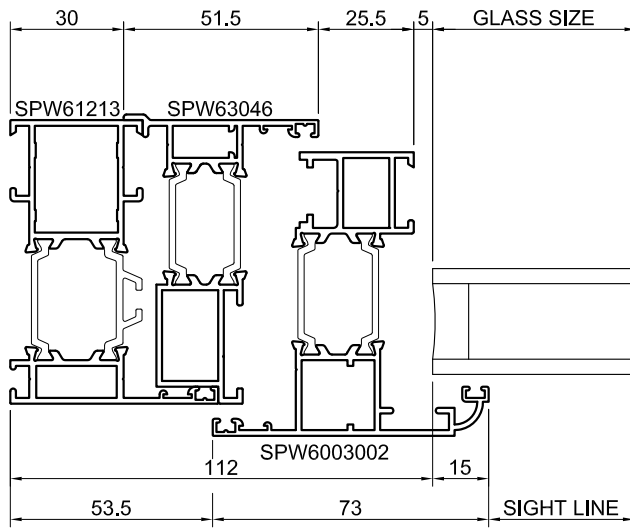

SPW600e Casement

Deductions - Frame and Glass

SPW600e.D.108

04.12

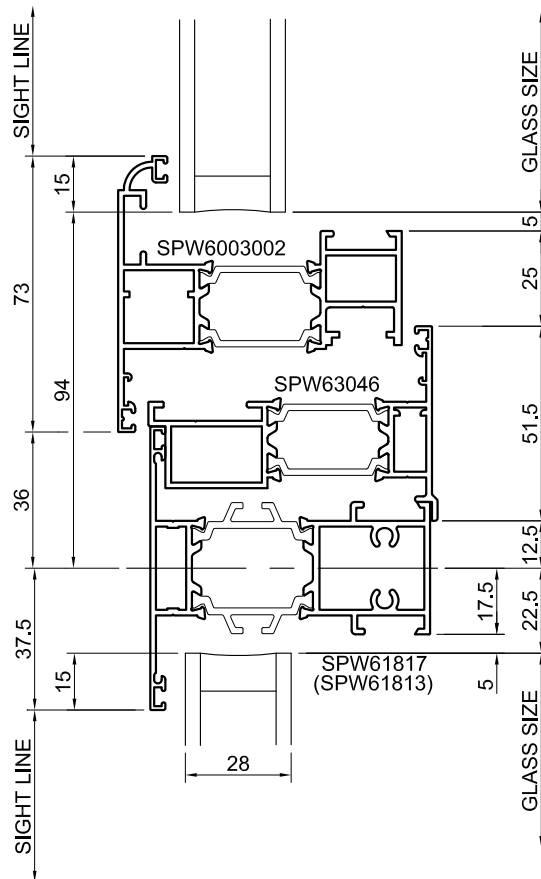
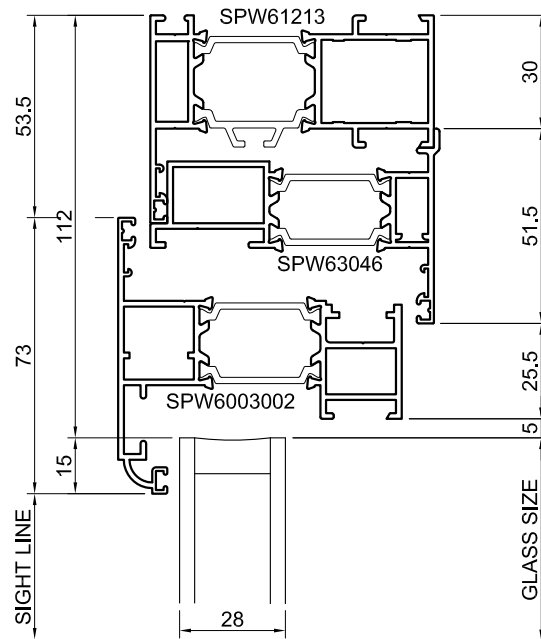

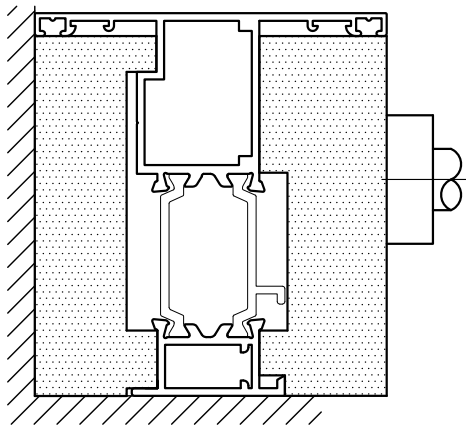

SPW60708
Internal Glaze Vent

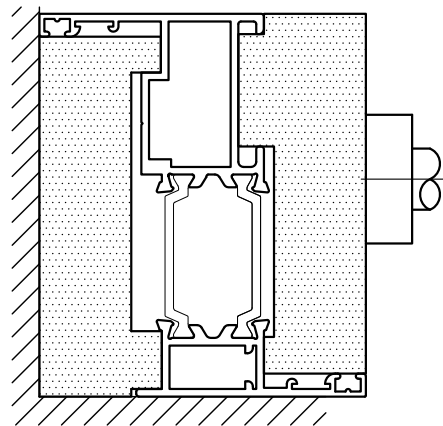

SPW60304
Casement Vent

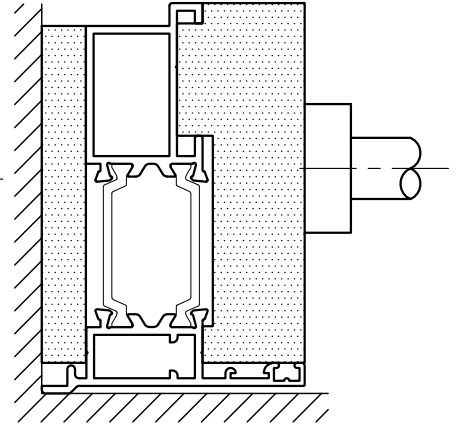

SPW63046
Casement Internal Glaze Adaptor

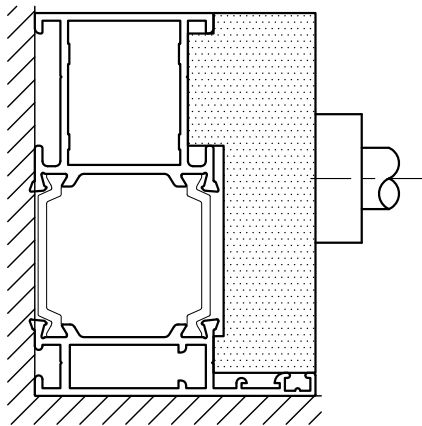

SPW60102
Casement Outer

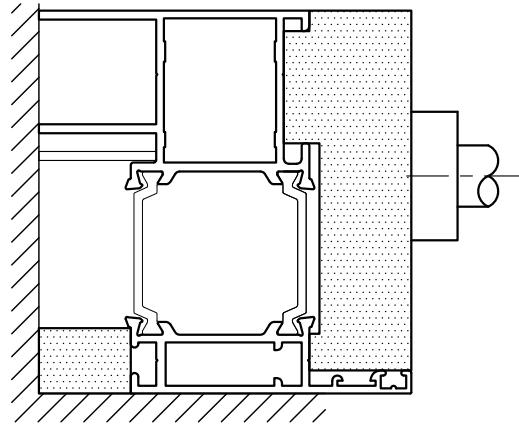

SPW66902
28mm Curtain Wall Casement Outer

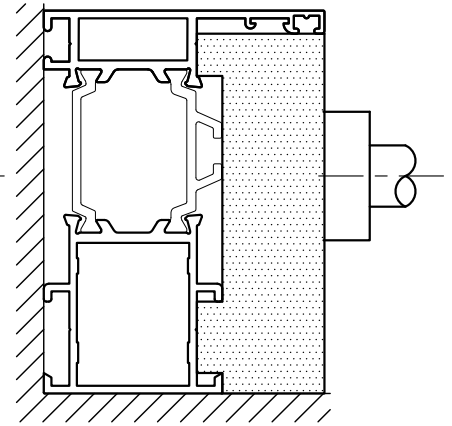

SPW61213
Outer Internal Glaze

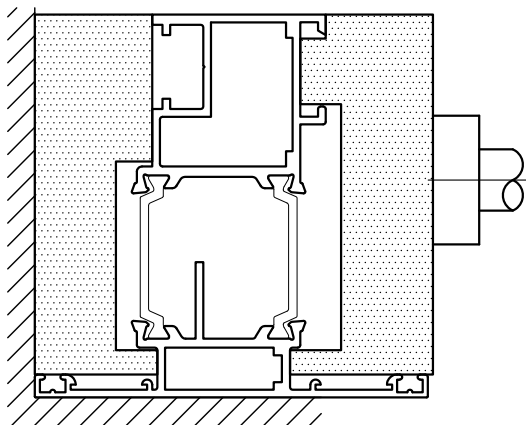

SPW68693
Espag Vent

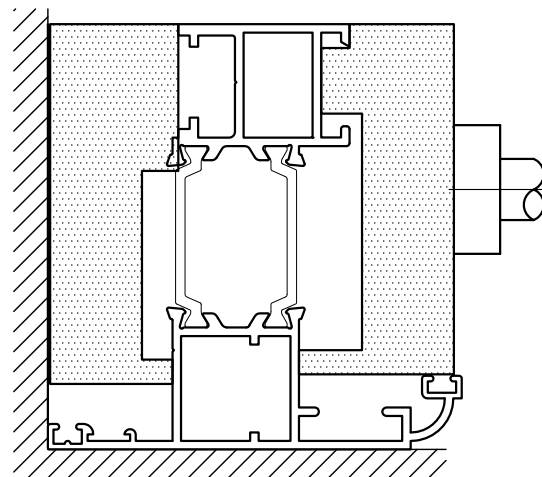

SPW6003002
A & B Rated Espag Sash

SPW600e Casement

Drainage - External Glazed

SPW600e.D.110

04.12

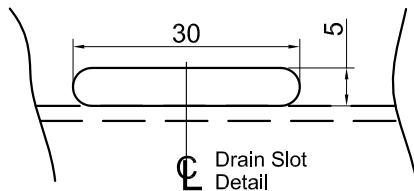
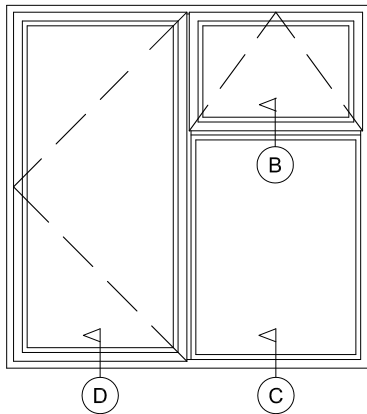

MACHINE DRAINAGE SLOTS 65mm FROM CORNER
OF GLAZING APERTURE AT A MINIMUM OF
600mm CENTRES
REMOVE WEATHERSEAL LOCALLY TO DRAIN SLOT.
SEE DRAIN CILLS IN SECTION 'G'

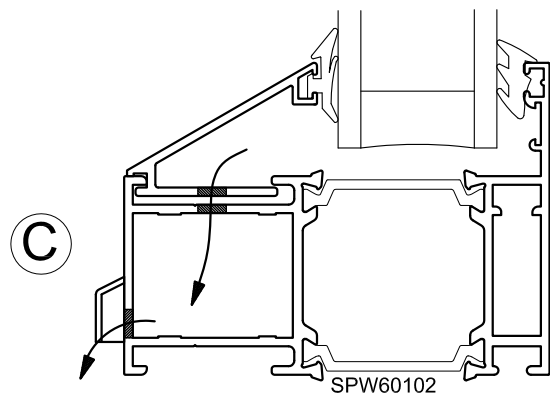
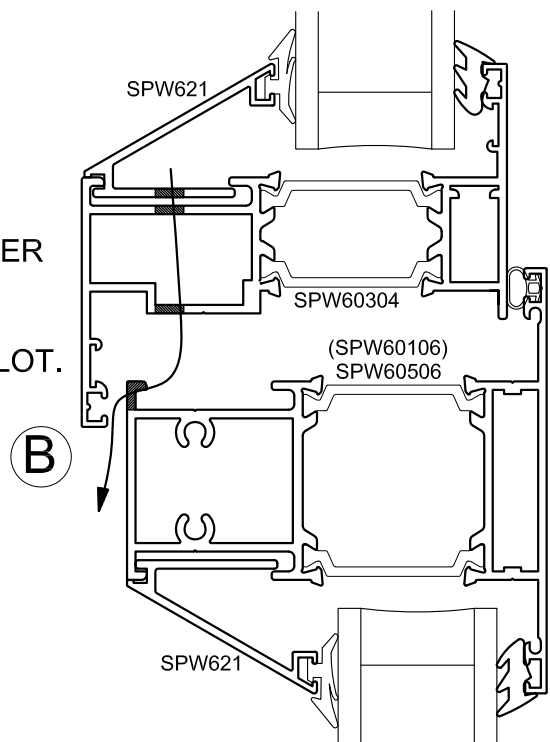
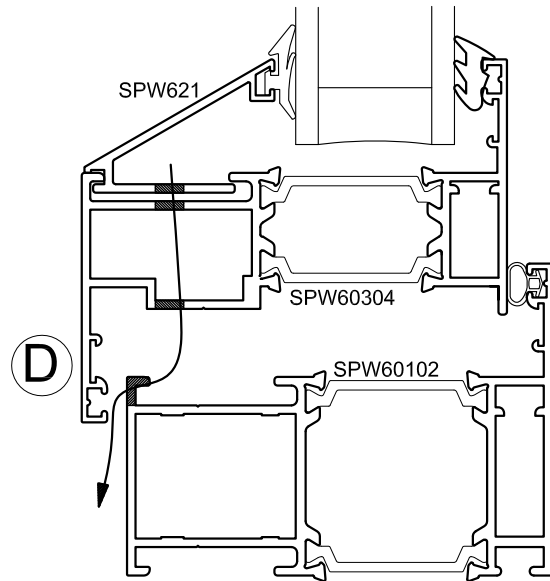

SPW600e.D.111

04.12

SPW600e Casement

Drainage - Internal Glazed

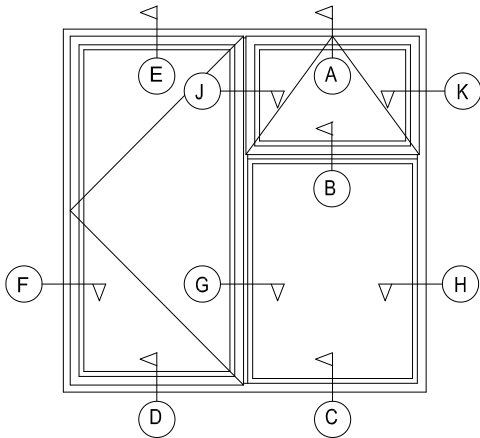

Typical Outside Elevation

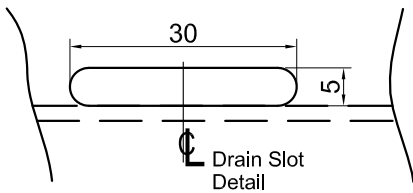

MACHINE DRAINAGE SLOTS 65mm FROM CORNER OF GLAZING APERTURE AT A MINIMUM OF 600mm CENTRES
 REMOVE WEATHERSEAL LOCALLY TO DRAIN SLOT. SEE DRAIN CILLS IN SECTION 'G'

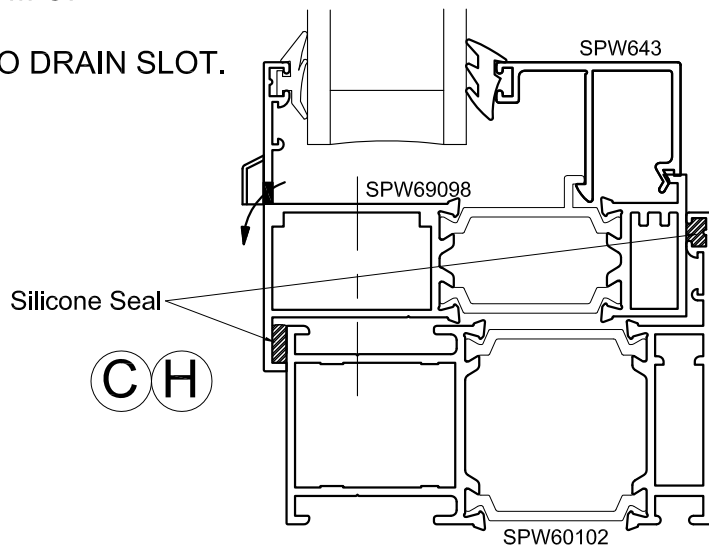
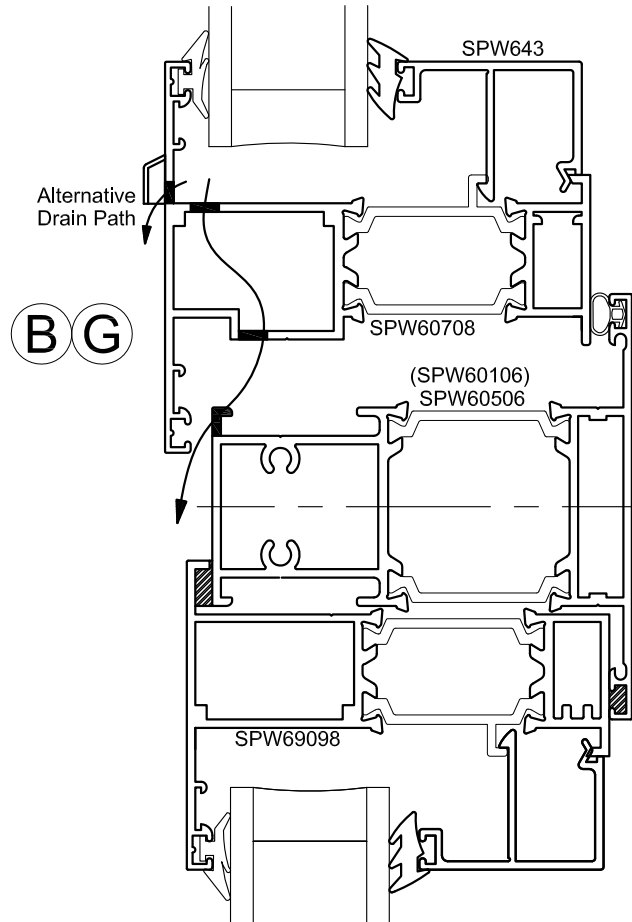

SPW600e Casement

Drainage - Internal Glazed

SPW600e.D.112

04.12

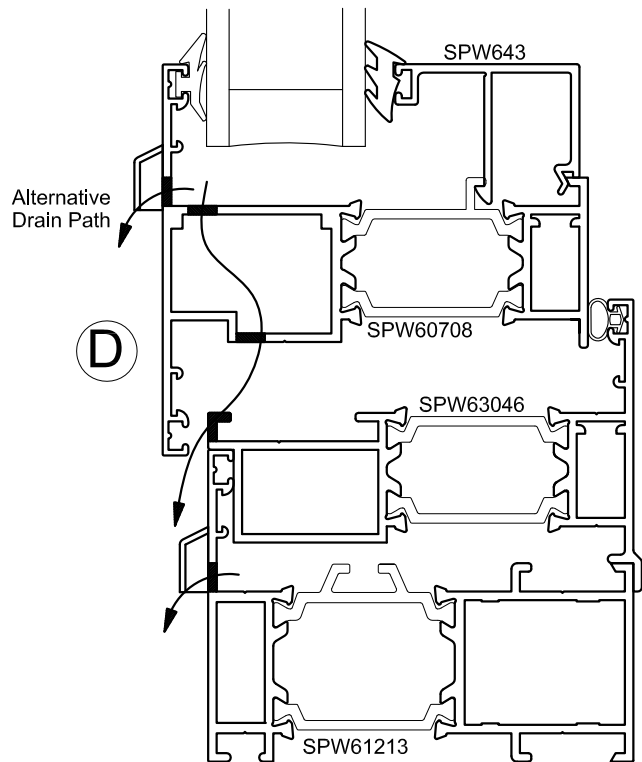
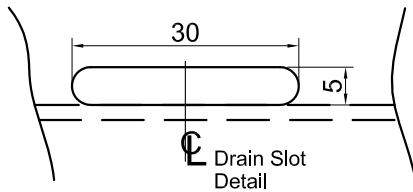
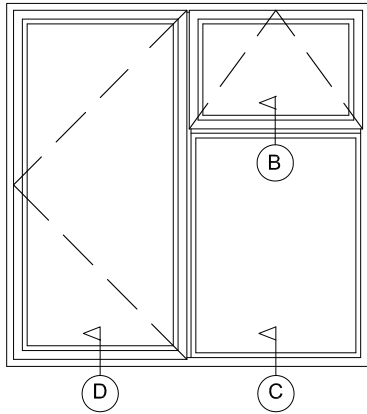

MACHINE DRAINAGE SLOTS 65mm FROM CORNER OF GLAZING APERTURE AT A MINIMUM OF 600mm CENTRES
REMOVE WEATHERSEAL LOCALLY TO DRAIN SLOT. SEE DRAIN CILLS IN SECTION 'G'

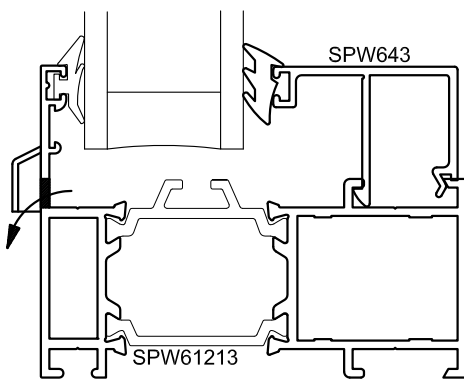

C

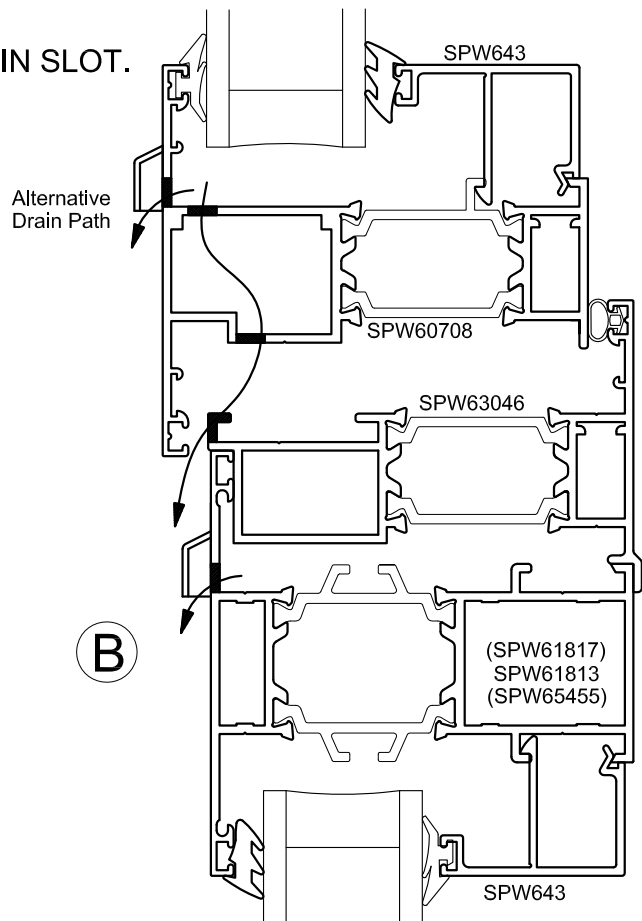

B

SPW600e Casement

Drainage - Internal Glazed

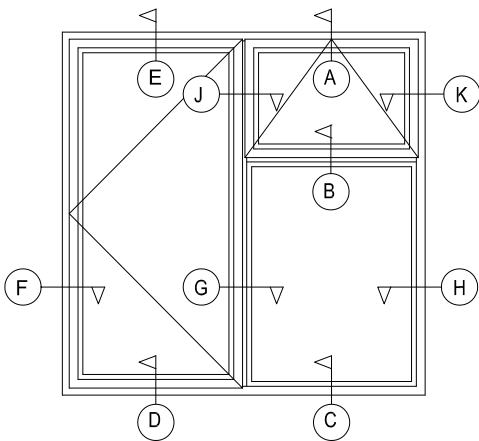

Typical Outside Elevation

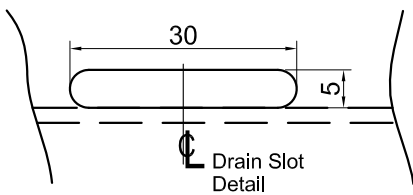

MACHINE DRAINAGE SLOTS 65mm FROM CORNER OF GLAZING APERTURE AT A MINIMUM OF 600mm CENTRES
 REMOVE WEATHERSEAL LOCALLY TO DRAIN SLOT. SEE DRAIN CILLS IN SECTION 'G'

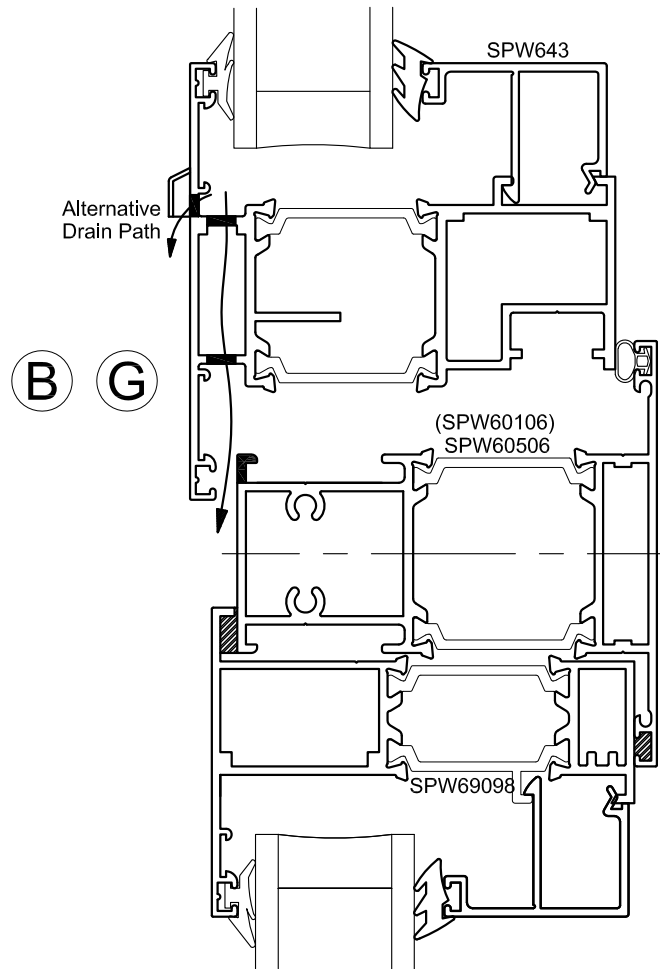

(B) (G)

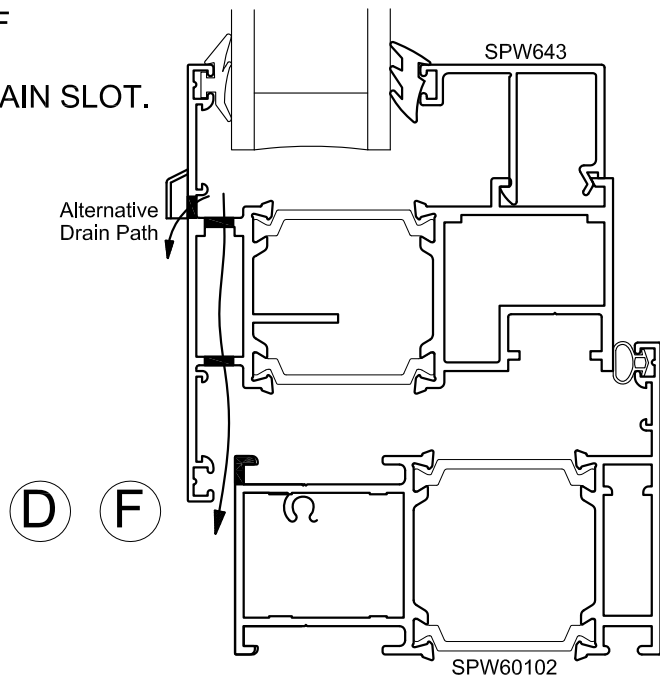

(D) (F)

SPW600e Casement

Drainage - Internal Glazed

SPW600e.D.114

04.12

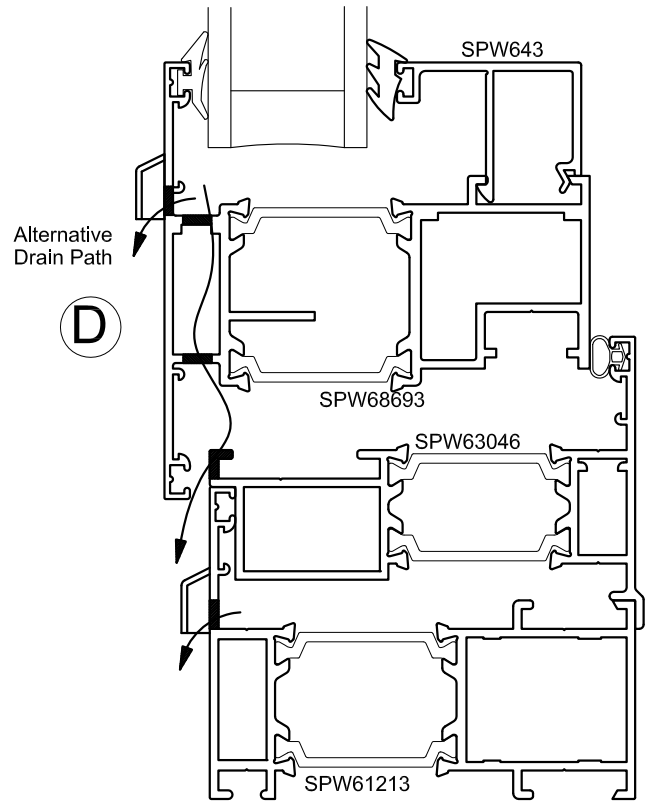
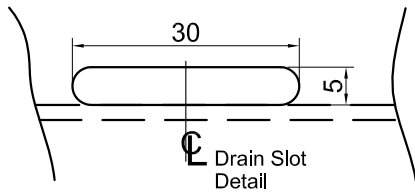
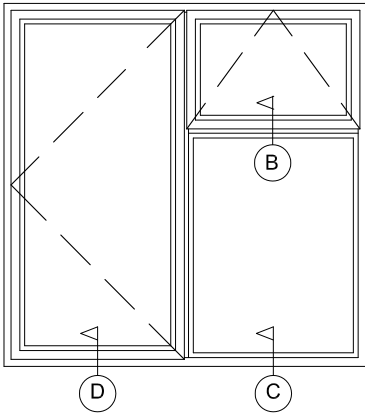

MACHINE DRAINAGE SLOTS 65mm FROM CORNER OF GLAZING APERTURE AT A MINIMUM OF 600mm CENTRES
REMOVE WEATHERSEAL LOCALLY TO DRAIN SLOT.
SEE DRAIN CILLS IN SECTION 'G'

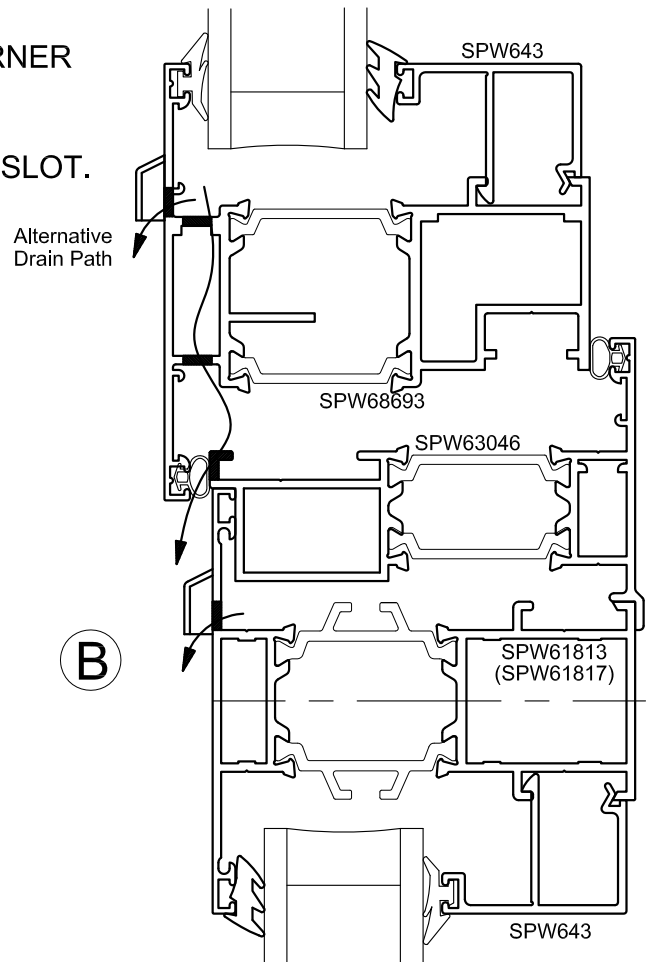

SPW600e.D.115

04.12

SPW600e Casement

28mm Drainage Bead External Glazed

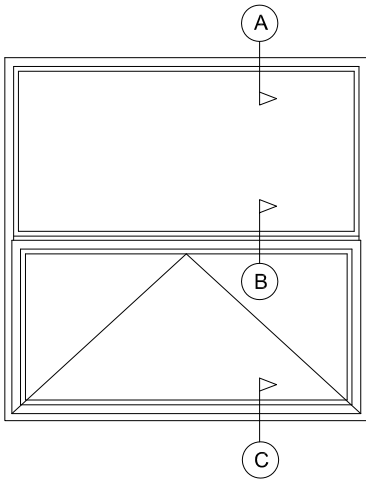

Typical Outside Elevation

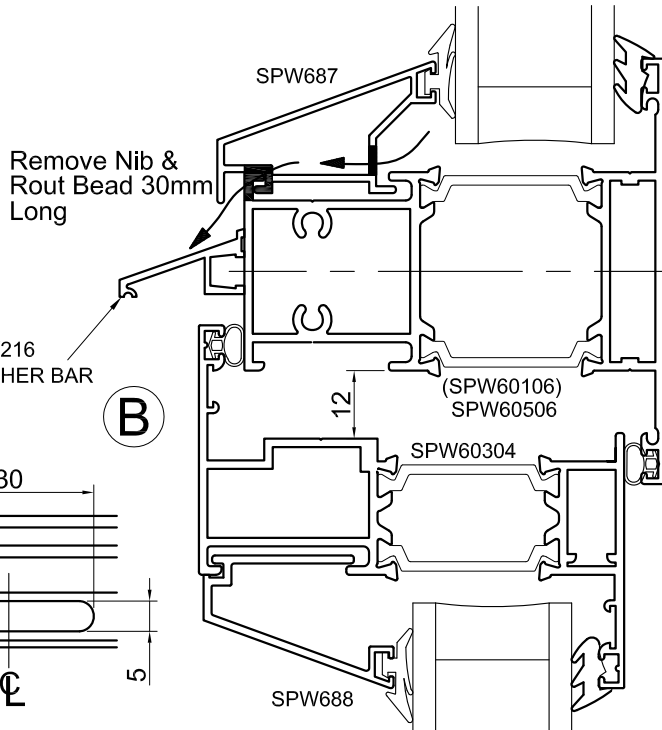
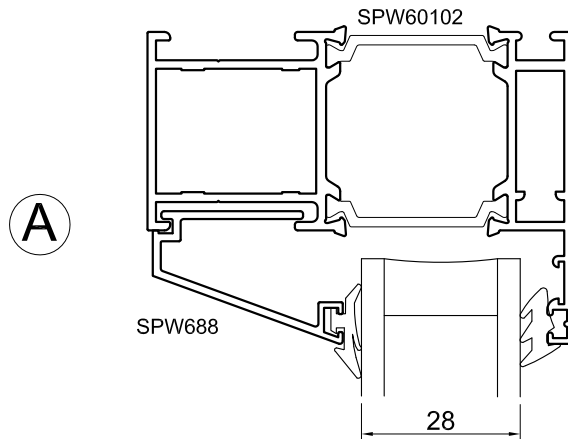

Remove Nib & Rout Bead 30mm Long

SXTW216 WEATHER BAR

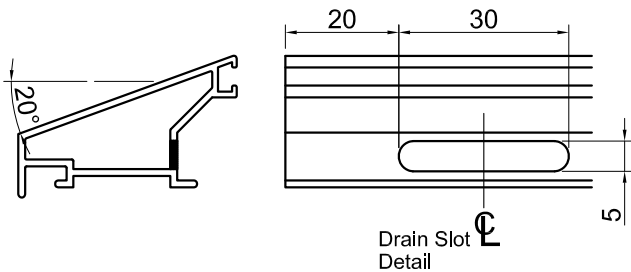

Drain Slot Detail

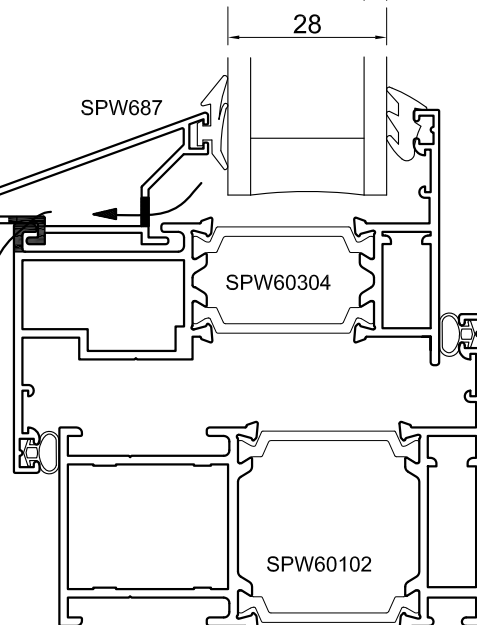

Remove Nib & Rout Bead 30mm Long

MACHINE DRAINAGE SLOTS 20mm FROM CORNER OF GLAZING APERTURE
 CUT HORIZONTAL BEAD SQUARE AND MITRE VERTICAL BEADS AT 20°

SPW600e Casement

32mm Drainage Bead External Glazed

SPW600e.D.116

04.12

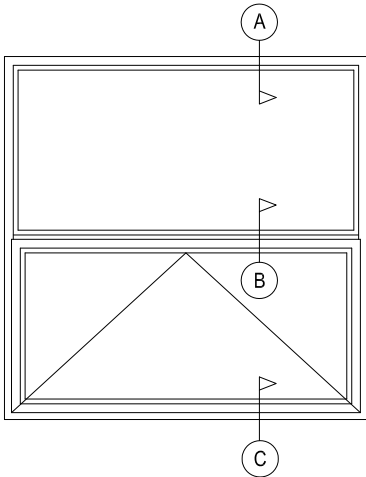

Typical Outside Elevation

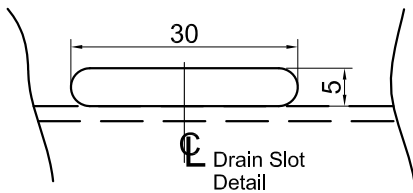

MACHINE DRAINAGE SLOTS
65mm FROM CORNER OF
GLAZING APERTURE AT A
MINIMUM OR 600mm CTRS.
REMOVE WEATHERSEAL
LOCALLY TO DRAIN SLOT.
SEE DRAIN CILL IN SECTION
"G"

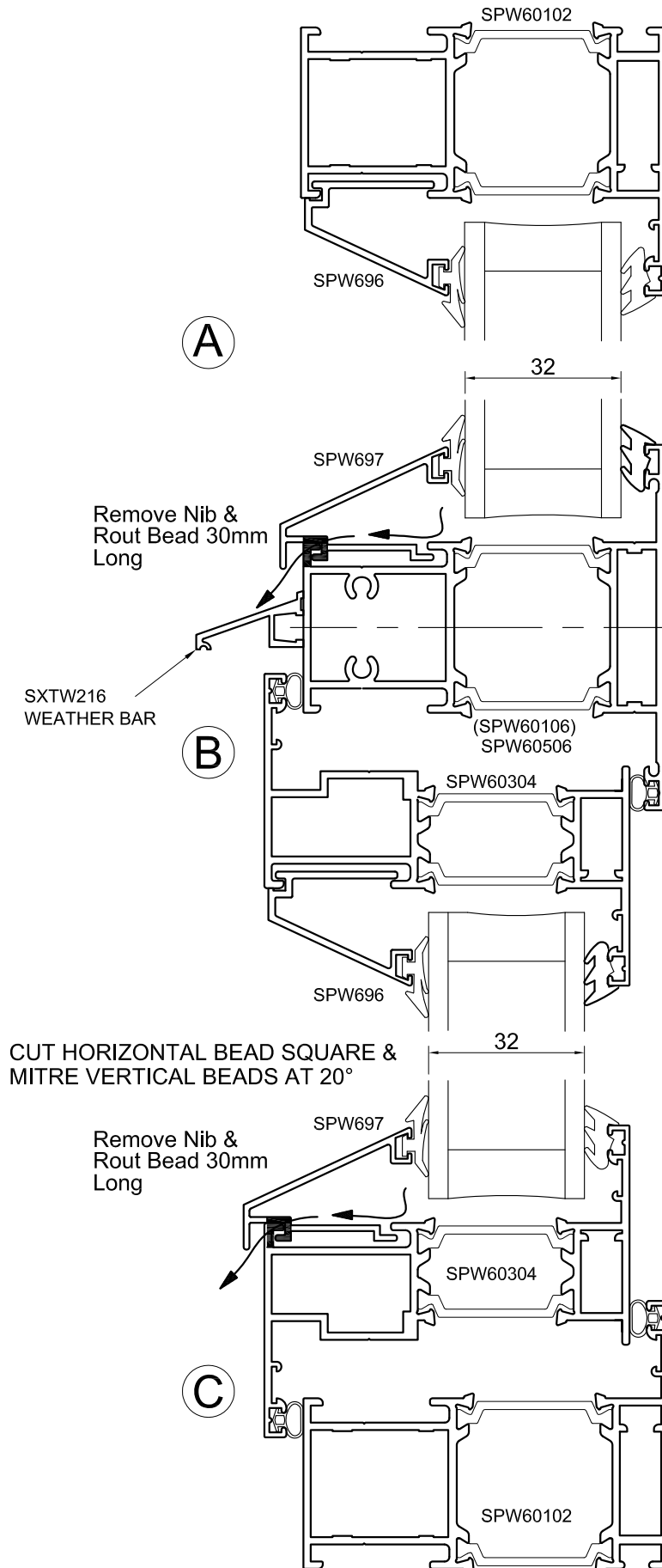

SPW600e.D.117

04.12

SPW600e Casement

Drainage - SPW6003002 Vent Only

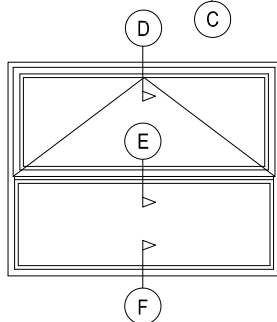
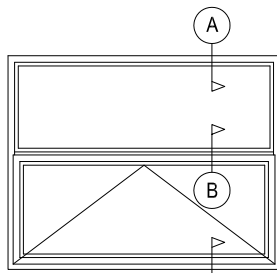

Typical Outside Elevation

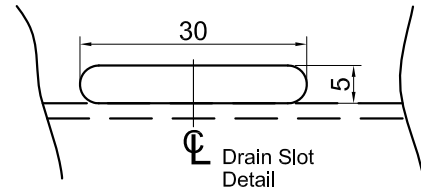

MACHINE DRAINAGE SLOTS 90mm FROM CORNER OF GLAZING APERTURE AT A MINIMUM OF 600mm CENTRES
REMOVE WEATHERSEAL LOCALLY TO DRAIN SLOT.
SEE DRAIN CILLS IN SECTION 'G'

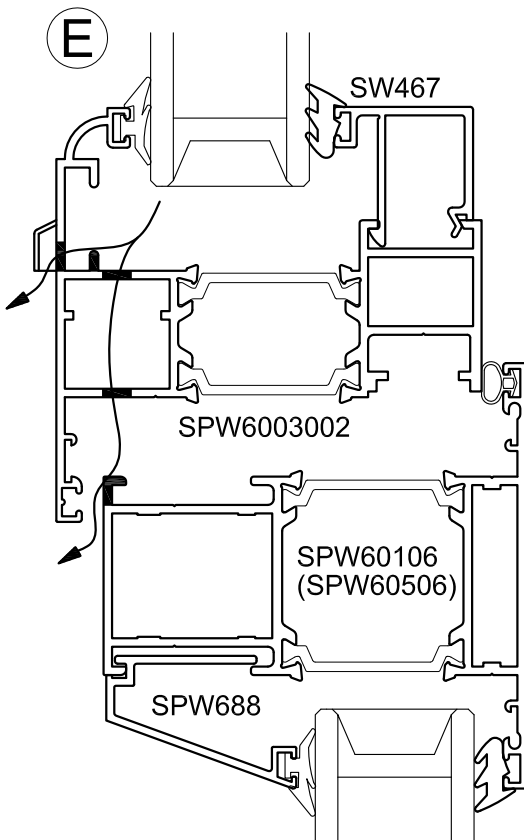

SXTW216 WEATHER BAR

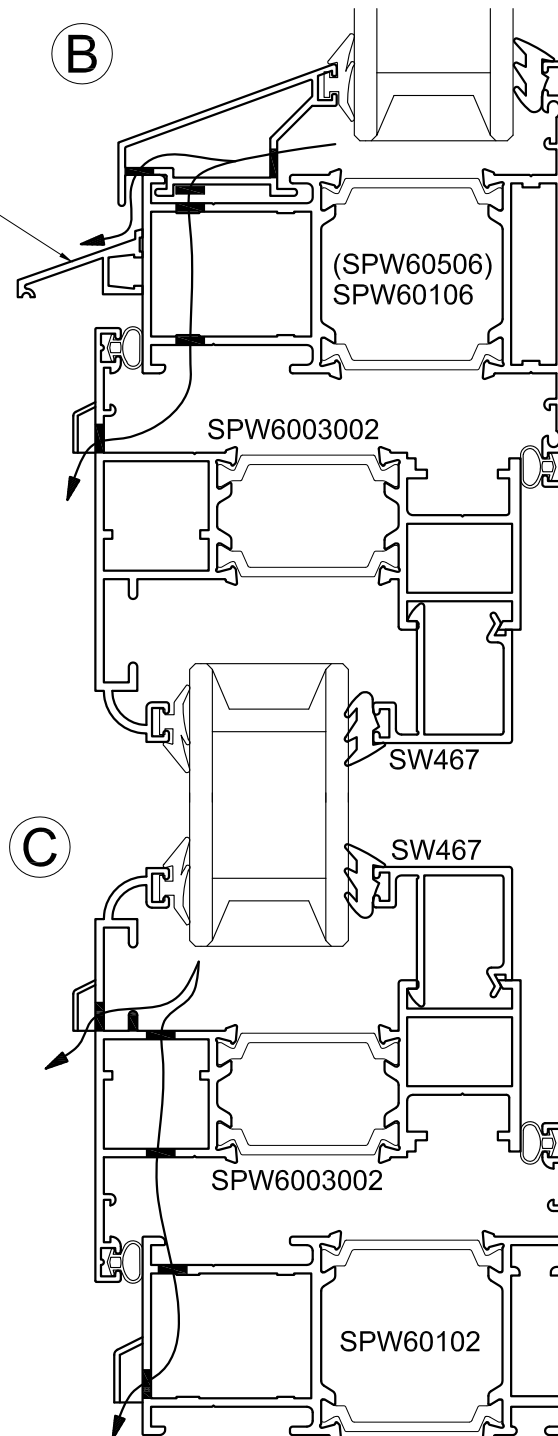

SPW600e Casement

Blank

SPW600e.D.118

04.12

This Page is Intentionally Left Blank

SPW600e.E.101

04.12

NOTE: CRUCIFORM JOINTS CAN ONLY BE FORMED USING SHEARBLOCKS

SPW600e Casement

Transom/Mullion (External Glazed) Shear Block and Screw Fix

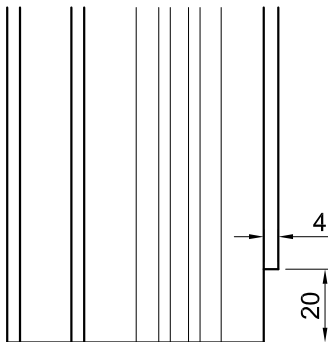
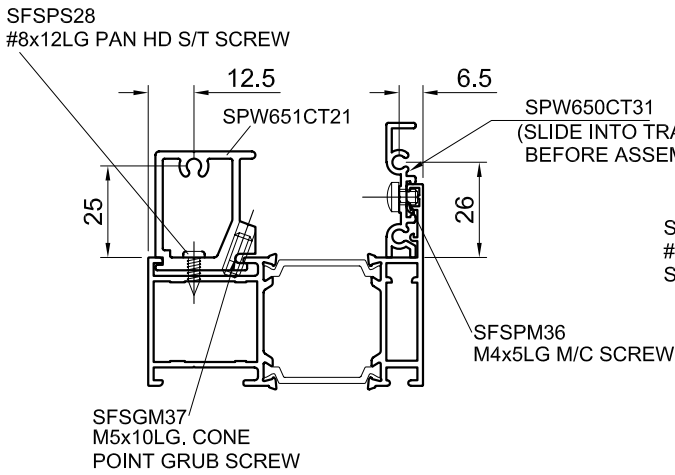

BAR END PREPARATION

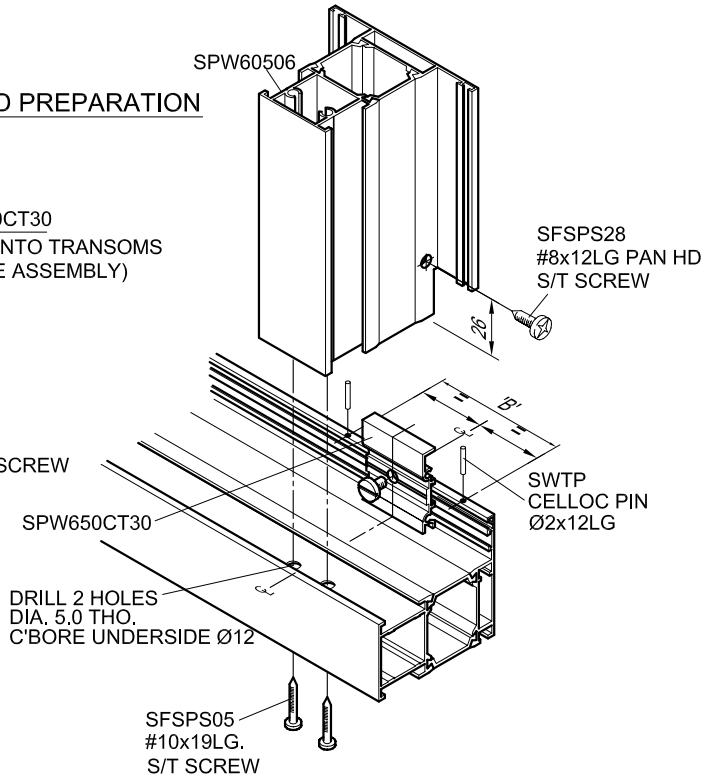
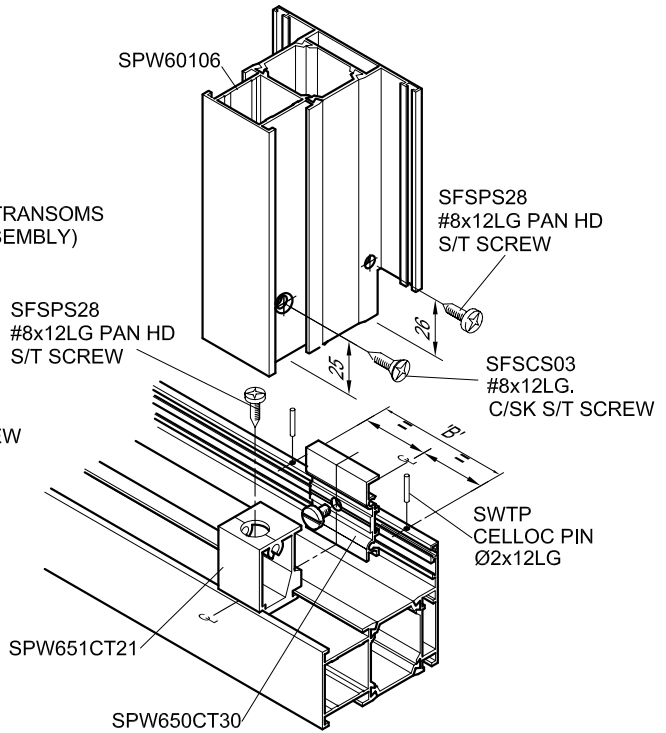
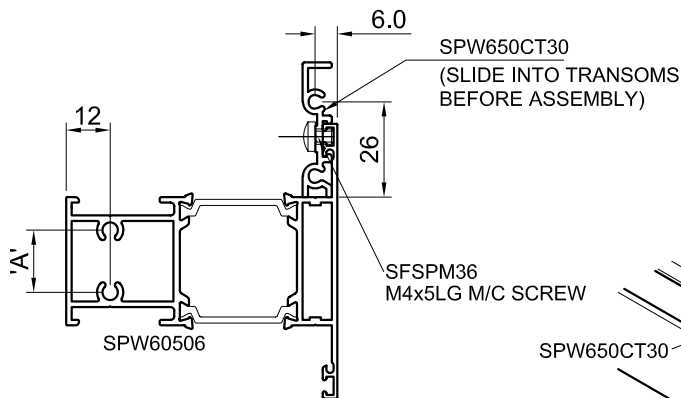

TRANSOM/MULLION OPTIONS				
TRANSOM	DIM 'A'	DIM 'B'	BLOCK INNER	BLOCK OUTER
SPW60506	17	58	SPW650CT30	N/A
SPW60106	N/A	58	SPW650CT30	SPW651CT21

SPW600e Casement

SPW600e.E.102

Transom / Mullion (Internal Glazed)
Shear Block and Screw Fix

04.12

NOTE: CRUCIFORM JOINTS CAN ONLY BE FORMED USING SHEARBLOCKS

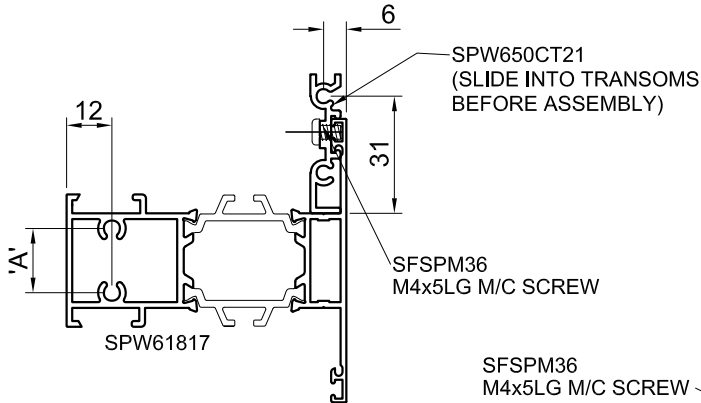
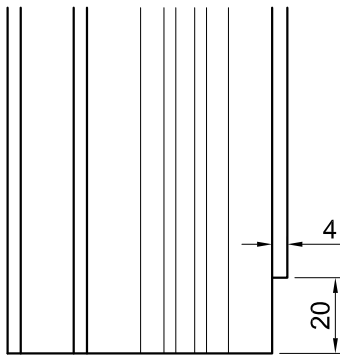
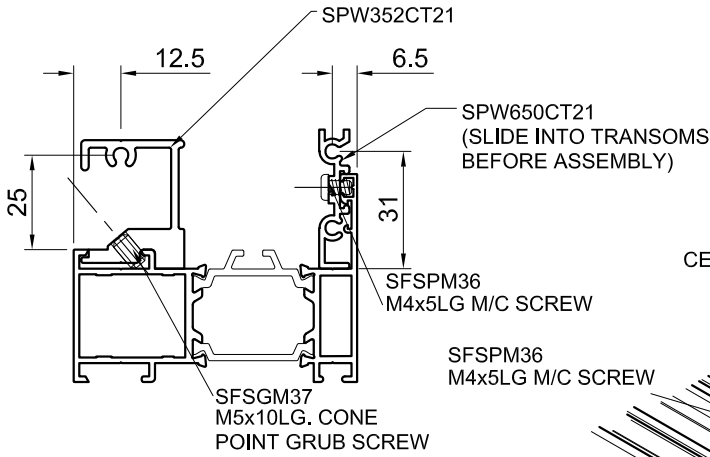

BAR END PREPARATION

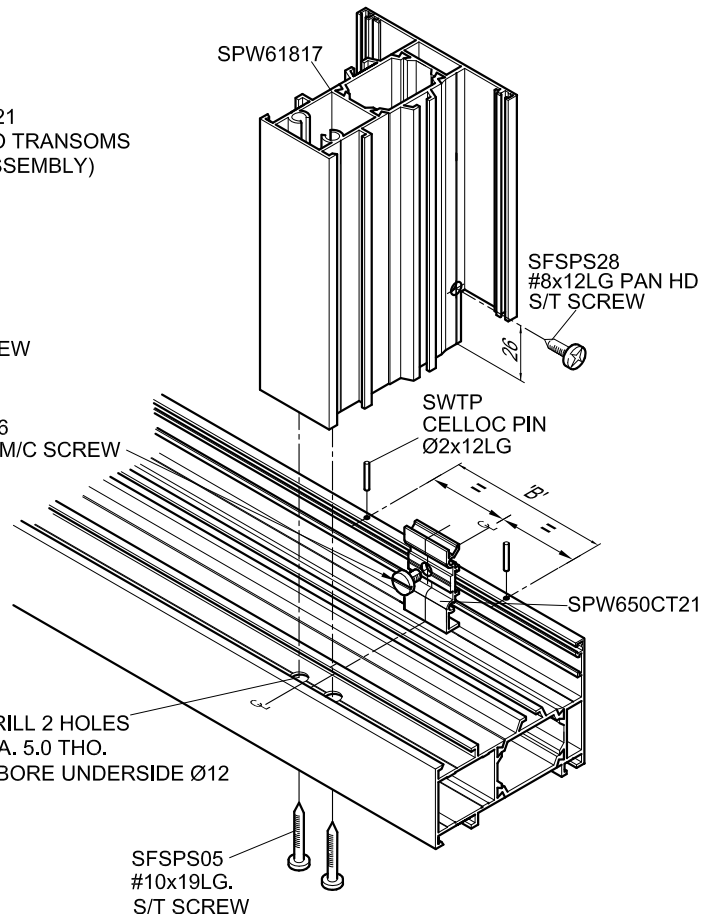
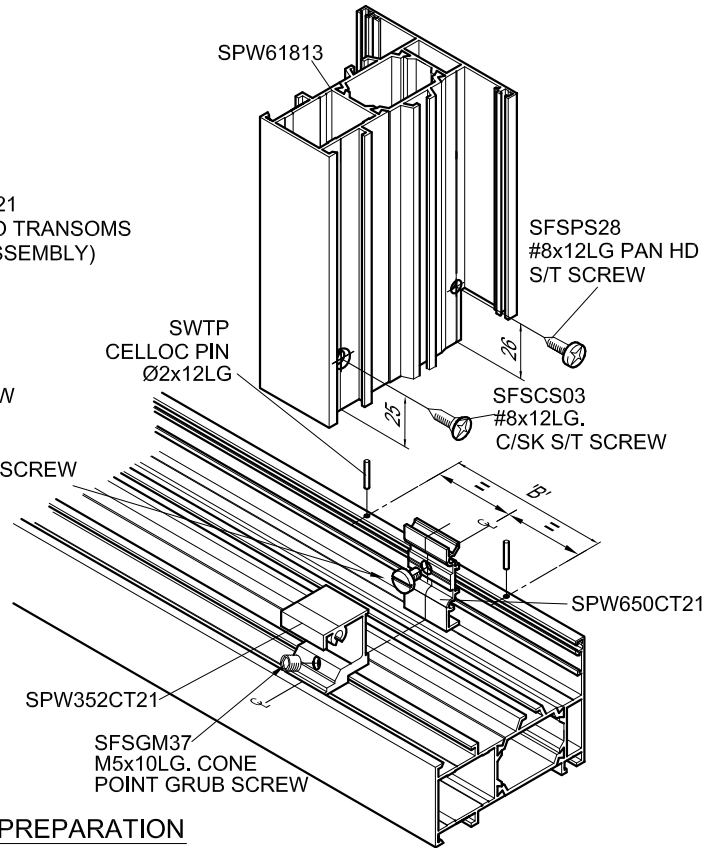

TRANSOM/MULLION OPTIONS				
TRANSOM	DIM 'A'	DIM 'B'	BLOCK INNER	BLOCK OUTER
SPW61813	N/A	58	SPW352CT21	SPW650CT21
SPW61817	17	58	N/A	SPW650CT21
SPW61940	N/A	68	SPW352CT31	SPW650CT30
SPW65455	62	93	SPW652CT58	SPW650CT66

SPW600e.E.103

04.12

SPW600e Casement

Transom/Mullion Shear Block and Screw Fix

NOTE: CRUCIFORM JOINTS CAN ONLY BE FORMED USING SHEARBLOCKS

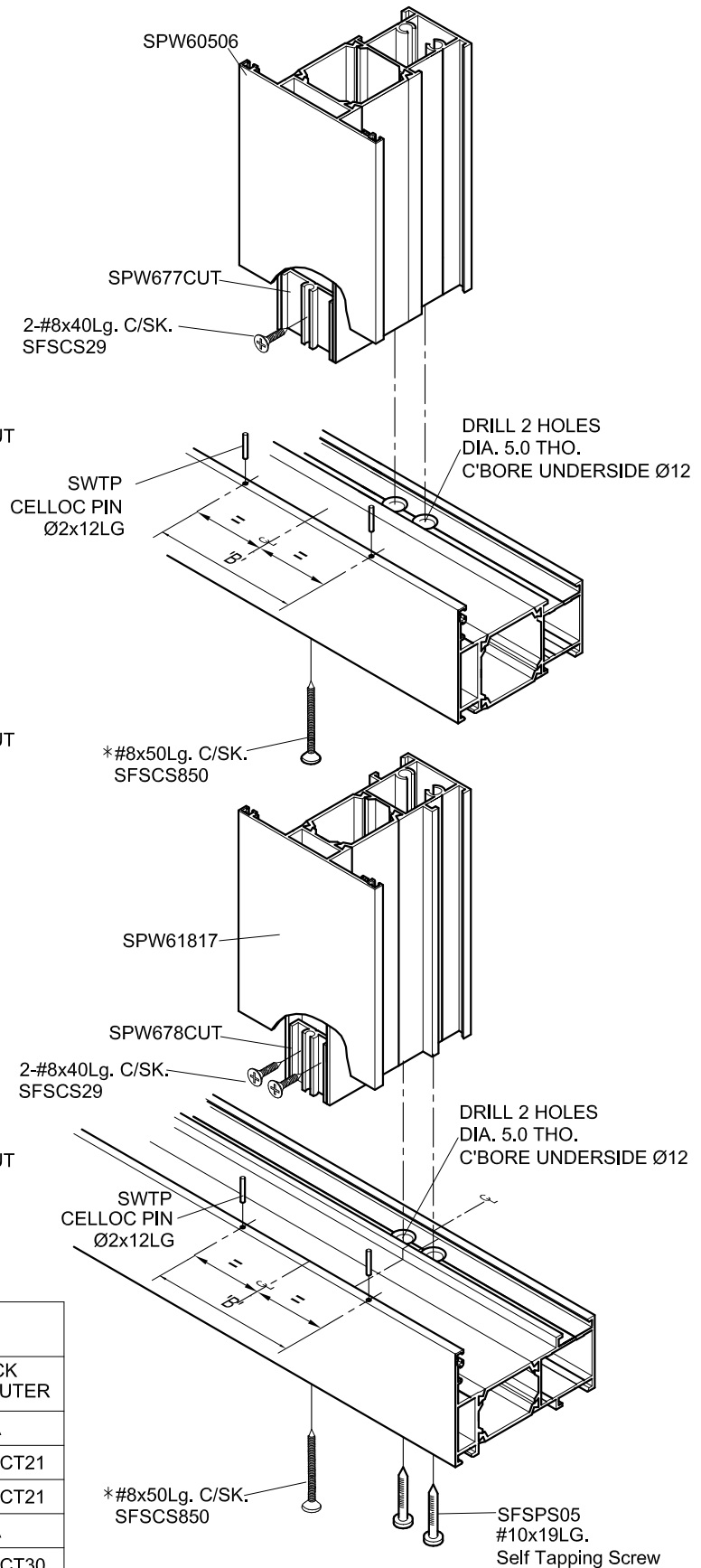
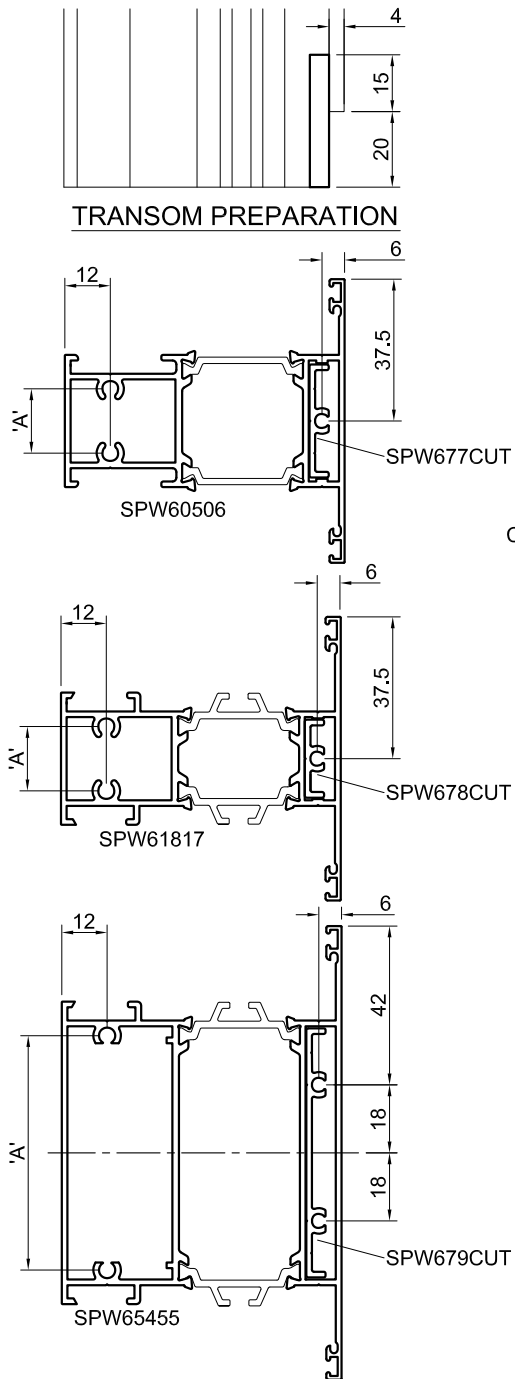

TRANSOM/MULLION OPTIONS				
TRANSOM	DIM 'A'	DIM 'B'	SHEAR BLOCK	BLOCK INNER/OUTER
SPW60506	17	58	SPW677CUT	N/A
SPW60106	N/A	58	SPW677CUT	SPW651CT21
SPW61813	N/A	58	SPW678CUT	SPW652CT21
SPW61817	17	58	SPW678CUT	N/A
SPW61940	N/A	68	SPW677CUT	SPW652CT30
*SPW65455	62	93	SPW679CUT	SPW652CT58

* NOTE: USE 2 SCREWS SFSCS850 18mm EITHER SIDE OF \bar{C}

SPW600e Casement

SPW600e.E.104

Corner Cleats & Thermal Inserts For Crimped Sections

04.12

Seal All Mitre Joints,
Also Corner Cleats To Seal
For Through Drainage
With Propriety Sealant.

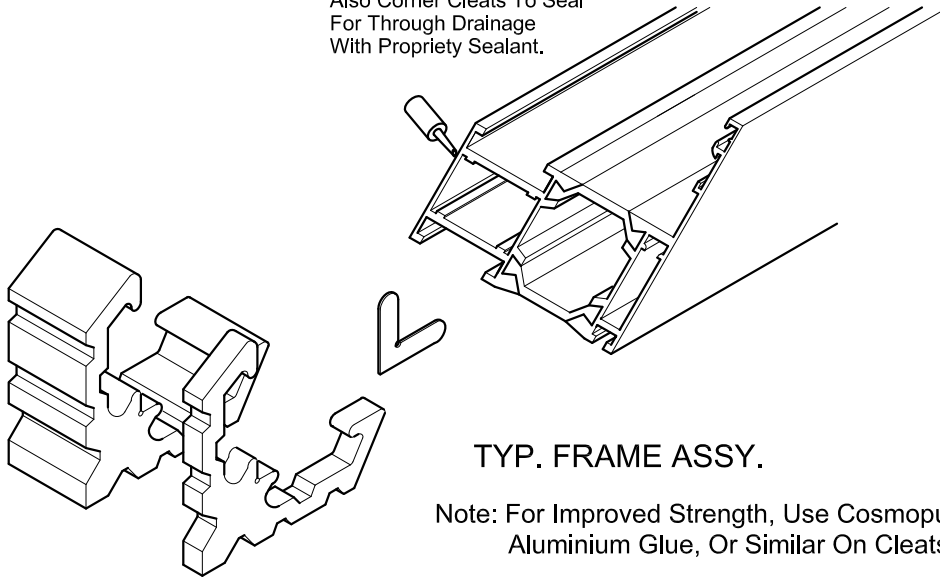

TYP. FRAME ASSY.

Note: For Improved Strength, Use Cosmopur 819 (300ml) 3COS0073 Aluminium Glue, Or Similar On Cleats Before Assembly.

SECTION	INNER CLEAT	OUTER CLEAT	OUTER CHEVRON	INNER CHEVRON
SPW60102	SW445CT8	SW445CT28	N/A	SW4CH7/CHEV7P
SPW61213	SW445CT8	SW445CT28	SW4CH7/CHEV7P	N/A
SPW60708	SPW645CT8	SPW645CT28	SW4CH7/CHEV7P	N/A
SPW63046	SPW645CT8	SPW645CT24	N/A	SW4CH7/CHEV7P
SPW60304	SPW645CT8	SXTW281CT28C OR SXTW281CT28M	SW4CH7/CHEV7P	SW4CH7/CHEV7P
SPW66902	SW445CT8	SW445CT28	N/A	SW4CH7/CHEV7P
SPW69098	SPW645CT8	SPW645CT28		N/A
SPW68693	SPW645CT28	SW445CT8	SW4CH15/CHEV15P	N/A
SPW6003002	SXTW281CT18	SXTW281CT18 & SH881A	N/A	SW4CH7/CHEV7P

CRIMPED SECTIONS ONLY INSERTS FOR ENHANCED THERMAL PERFORMANCE		
SECTION	INSERT	UNDER GLASS INSERT
SPW60102	EPS001	EPS006 (FIXED ONLY)
SPW61213	EPS003	EPS006 (FIXED ONLY)
SPW60708	EPS004	EPS005
SPW63046	EPS004	NA
SPW60304	EPS004	EPS006
SPW64402	EPS001	NA
SPW66902	EPS001	NA
SPW69098	EPS004	EPS005
SPW68693	EPS002	EPS005
SPW6003002	EPS003	EPS005

SPW600e.E.105

04.12

SPW600e Casement

Preparation - Defender Friction Stay Top Hung and Side Hung Applications

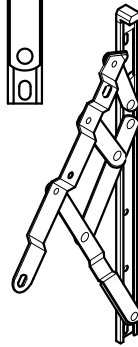
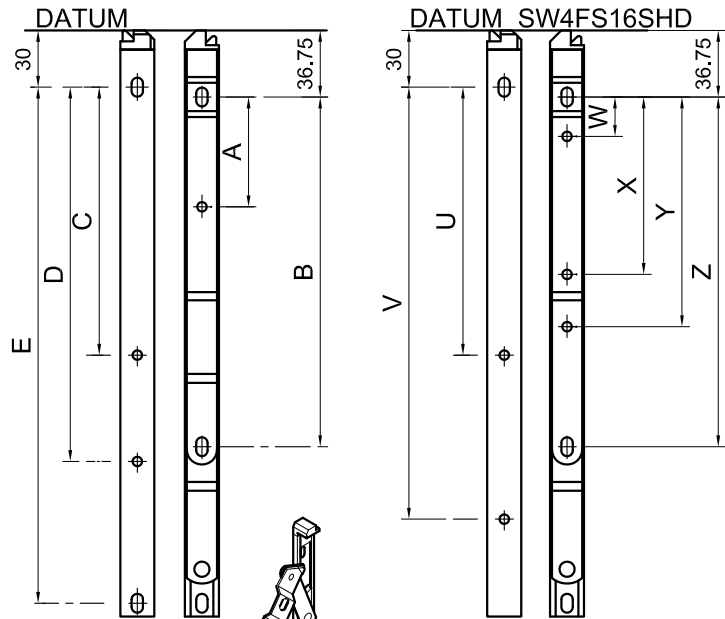
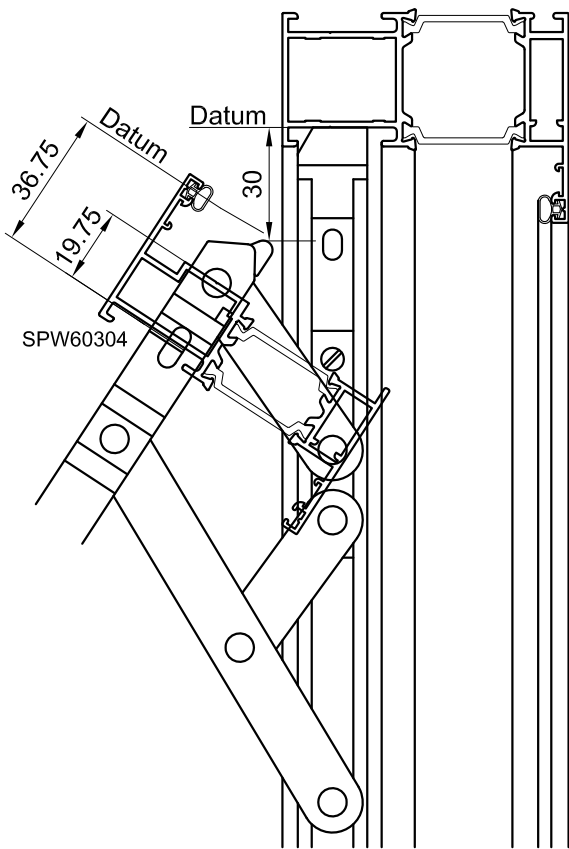

Recommended Stay Size:
Two Thirds Vent Height for
Top Hung (subject to weight limit)
16mm Stack Height Stays

STAY CODE	STAY SIZE	OPERATION	OPENING ANGLE	MAX. SASH WT.	MIN H	MAX H	DIMENSION (mm)					
							A	B	C	D	E	
SW4FS08	203mm (8")	Top Hung	65°	12Kg	200	350	18.2	118.6	141		172.5	
SW4FS10	254mm (10")	Top Hung	80°	16Kg	275	400	32.25	152.75	179.9		223.5	
SW4FS12TH	304mm (12")	Top Hung	80°	20Kg	350	550	47.25	188.25	209.5		274	
SW4FS16	406mm (16")	Top Hung	80°	21Kg	500	780	106	228.6	281.2		375.6	
SW4FS20	508mm (20")	Top Hung	50°	26Kg	700	1100	170.5	271.75	246.8		477.2	
SW4FS24	610mm (24")	Top Hung	27°	50Kg	850	1500	220.5	322.5	195		578.8	
					MIN W	MAX W	A	B	C	D	E	
SW4FS12SH	304mm (12")	Side Hung	60°	22Kg	300	600	230.8	245	195		274	
SW4FS16SHE	406mm (16")	Side Hung	90°	24Kg	400	700	106	322.5	209.5	327	375.6	
					MIN W	MAX W	U	V	W	X	Y	Z
SW4FS16SHD	406mm (16")	Side Hung	60°	40Kg	400	900	192	388	35.4	90	137.6	297.6

NOTE: MAXIMUM WIDTH FOR TOP HUNG VENTS IS 1500mm, MAXIMUM HEIGHT FOR SIDE HUNG VENTS IS 1500mm.
MAINTANANCE: After fitting, & at 12 monthly intervals, the Friction Stay Pivot Points should be lubricated with a light machine oil. e.g. 3in1

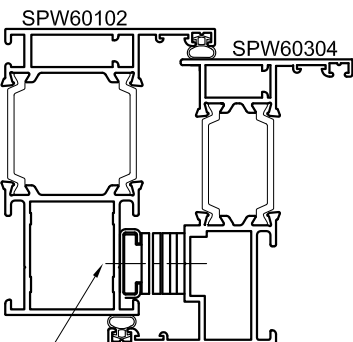

Fix With #8x3/8" Pan Hd Screws
Ref:SFSPS41

EXTERNAL GLAZED

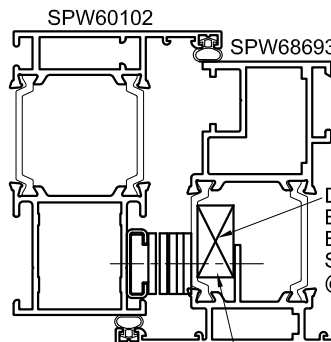

Fix With #8x19LG Pan Hd Screws
Ref:SFSPS33

INTERNAL GLAZED

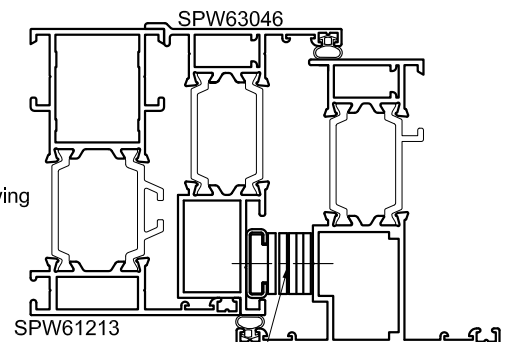

Fix With #8x3/8" Pan Hd Screws
Ref:SFSPS41

INTERNAL GLAZED

Detail Showing
Bracket For
BS7950
SW410 Cut
@ 21mm

SPW600e Casement

SPW600e.E.106

Preparation - Defender Friction Stay - T/H & S/H Applications
For Use With SPW6003002 Sash

09.13

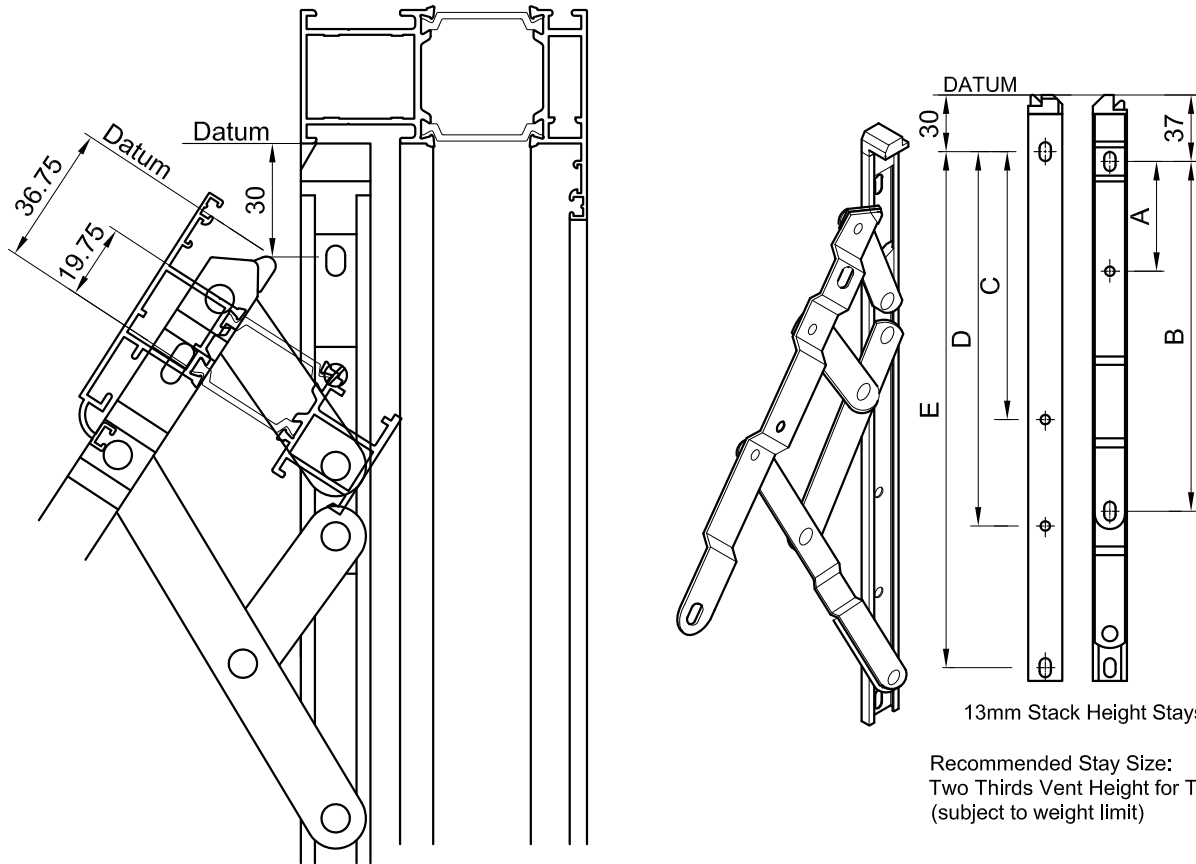

Recommended Stay Size:
Two Thirds Vent Height for Top Hung
(subject to weight limit)

STAY CODE	STAY SIZE	OPERATION	OPENING ANGLE	MAX. SASH WT.	VENT SIZES		DIMENSION (mm)				
					MIN HEIGHT	MAX HEIGHT	A	B	C	D	E
SWFS10	259mm (10")	Top Hung	80°	16Kg	275	400	32.25	152.75	179.9	-	223.2
SWFS12	310mm (12")	Top Hung	80°	20Kg	350	550	47.25	188.25	209.5	-	274.0
SWFS16	412mm (16")	Top Hung	80°	21Kg	500	780	106.0	228.6	281.2	-	375.6
SWFS20	513mm (20")	Top Hung	50°	26Kg	700	1100	170.5	271.75	246.8	-	477.2
SWFS24	615mm (24")	Top Hung	37.5°	40Kg	850	1300	220.5	322.5	195.0	-	578.8
SWFS24HD	615mm Heavy Duty	Top Hung	27°	50Kg	850	1500	220.5	332.5	195.0	-	578.8
					MIN WIDTH	MAX WIDTH					
SWFS12SH	310mm (12")	Side Hung	60°	22Kg	300	600	55.25	188.25	96.9	-	268.4
SWHEDSE12	310mm (12")	Side Hung	80°	22Kg	300	600	55.25	188.25	96.9	-	268.4
SWHEDSE16	412mm (16")	Side Hung	90°	24Kg	400	700	108.8	322.5	96.9	-	370.0

NOTE: MAXIMUM WIDTH FOR TOP HUNG VENTS IS 1500mm, MAXIMUM HEIGHT FOR SIDE HUNG VENTS IS 1500mm.

MAINTANANCE: After fitting, & at 12 monthly intervals, the Friction Stay Pivot Points should be lubricated with a light machine oil. e.g. 3in1

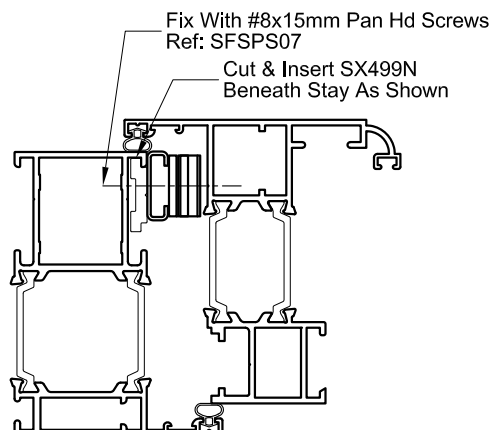

SPW600e.E.107

SPW600e Casement

04.12

Assembly - Preparation For 16mm Heavy Duty Friction Stays Securistyle "Sterling"

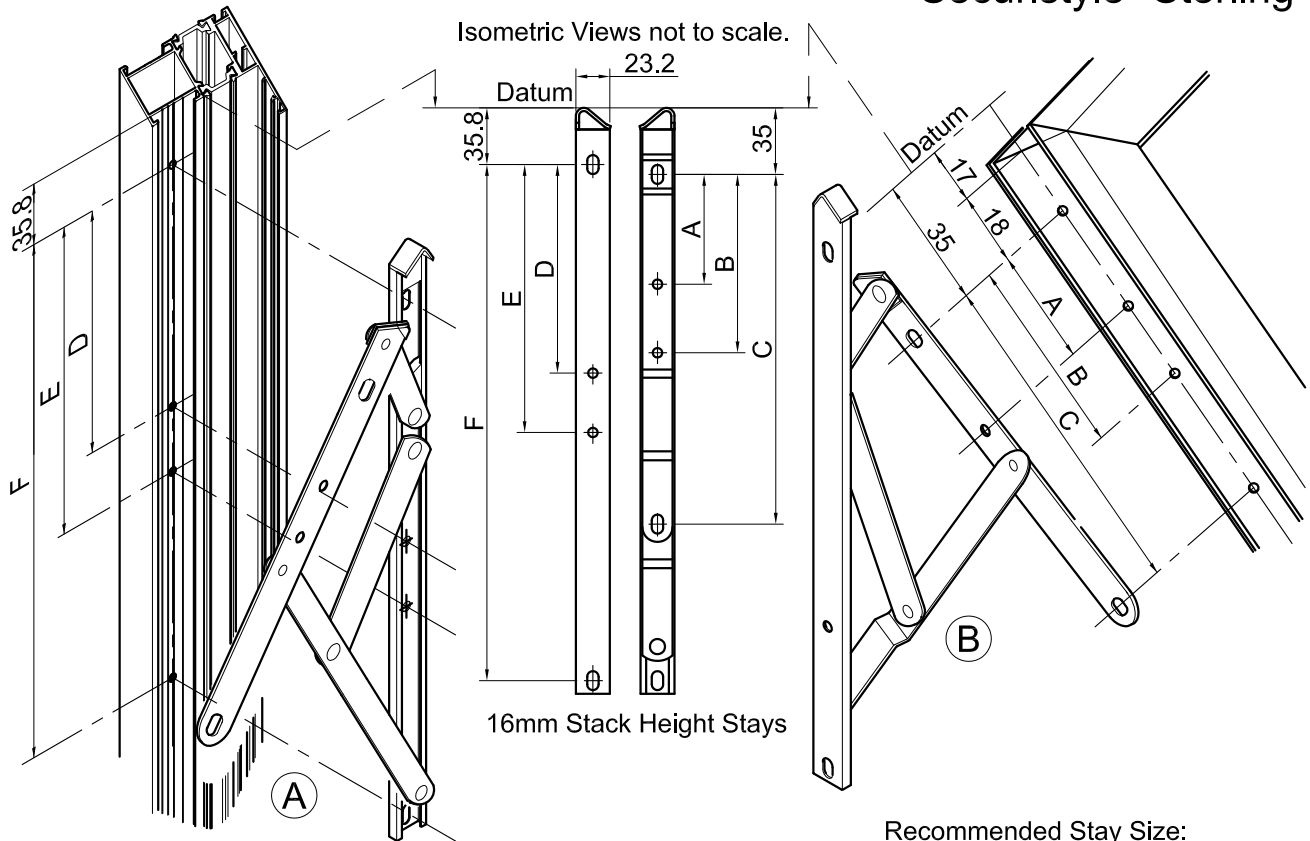

16mm Stack Height Stays

Recommended Stay Size:
Two Thirds Vent Height for Top Hung
(subject to weight limit)

Fit Securistyle Sterling With #10 x 1/2" Fixing Screws (SFSPS04)

STAY CODE	STAY SIZE	OPERATION	OPENING ANGLE	MAX. SASH WT.	MAX. VENT SIZE W X H	DIMENSION (mm)					
						A	B	C	D	E	F
SWST22	559mm (22")	Top Hung	45°	75Kg	1500 X 1500	65	203.2	317.4	251.3	418.3	523.0
SWSTS16	406mm (16")	Side Hung	90°	47Kg	836 X 1500	65	-	241.2	-	304.0	370.6

NOTE: MAXIMUM WIDTH FOR TOP HUNG VENTS IS 1500mm, MAXIMUM HEIGHT FOR SIDE HUNG VENTS IS 1500mm.

MAINTANANCE: After fitting, & at 12 monthly intervals, the Friction Stay Pivot Points should be lubricated with a light machine oil. e.g. 3in1

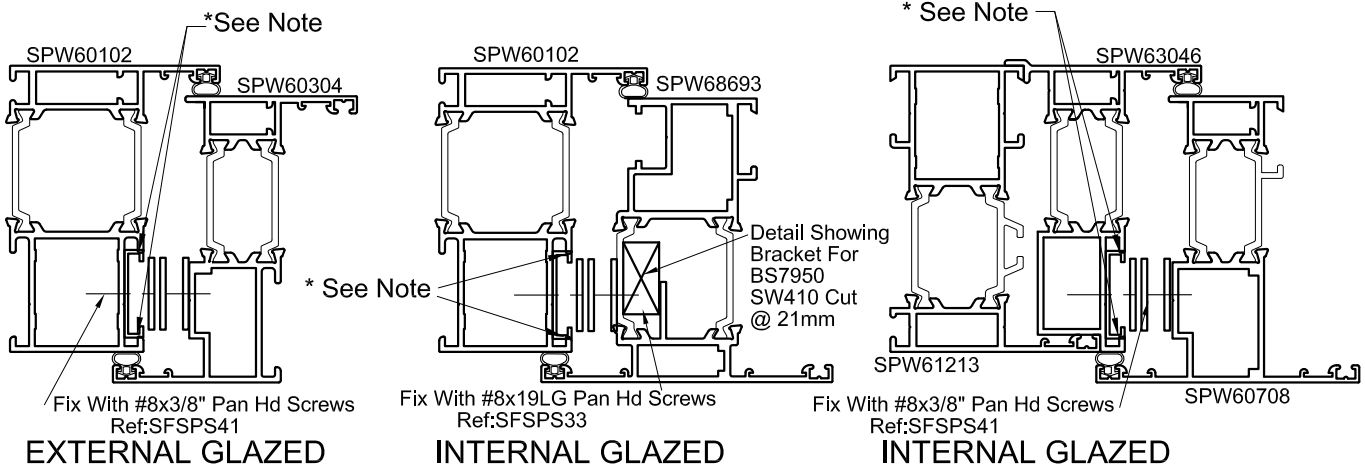

* Note = Remove Bead Carrier Nibs Locally To Length Of Stay

SPW600e Casement

SPW600e.E.108

Butt Hinge Preparation - Open Out

10.13

Hinge Ref: SPW6BUTTOOUTX
 Outward Opening Hinge
 REFER TO SECTION 'C' FOR HINGE FINISHES

Screws Supplied
 As Part Of Hinge

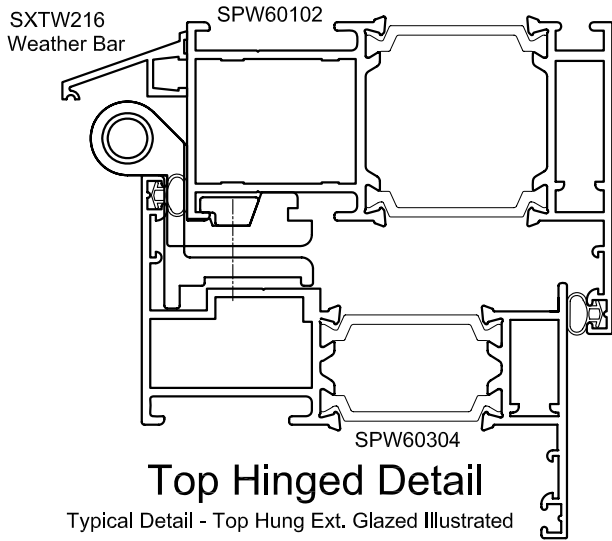

Outer Frame
 Inside View

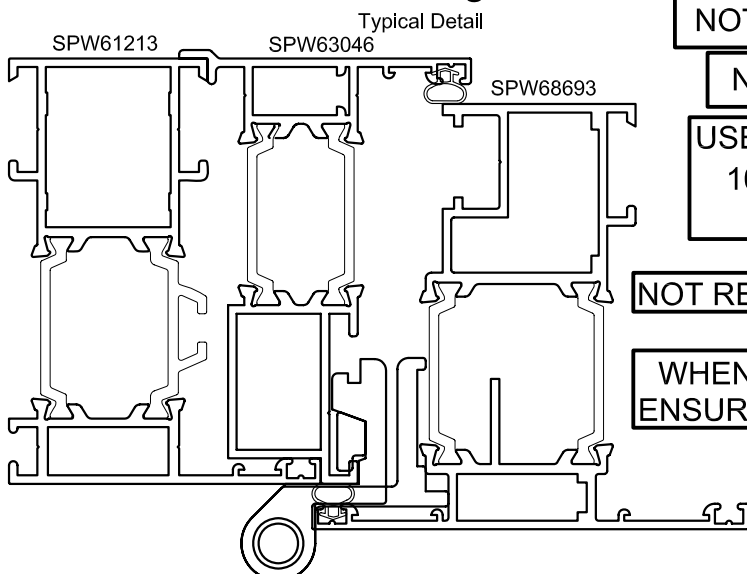
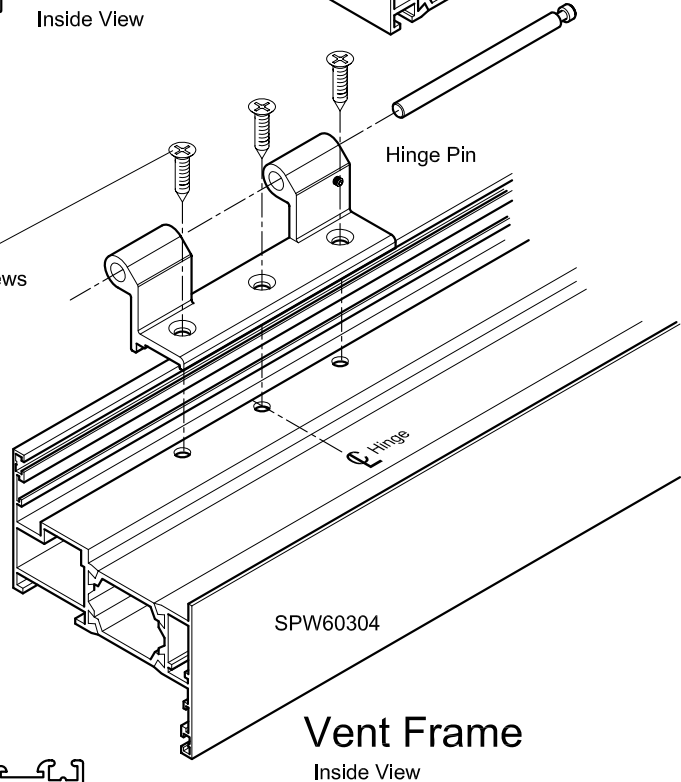
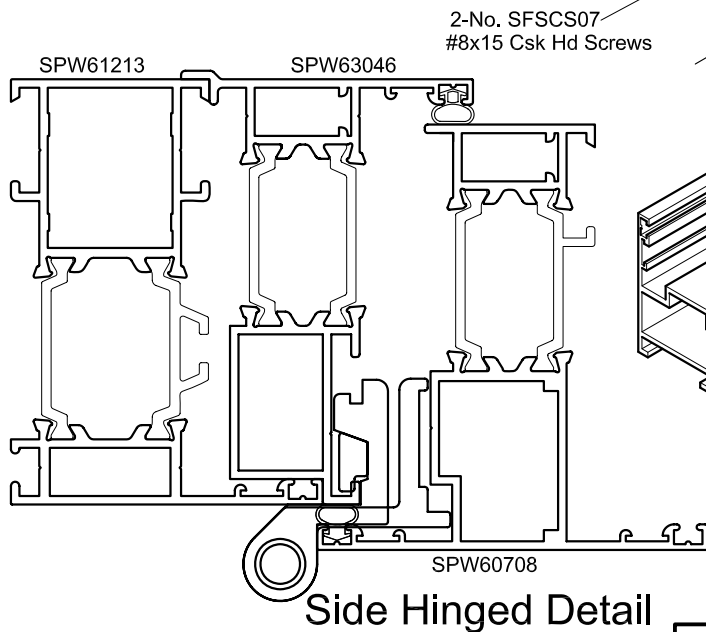
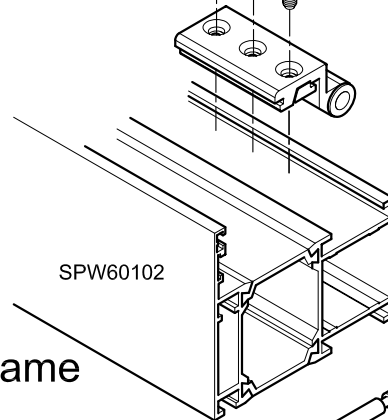

NOTE: MAX. WEIGHT OF SASH 50KGS.

NOTE: MIN VENT HEIGHT 550mm

USE TWO HINGES FOR VENTS UP TO 1000mm. USE THREE FOR VENTS OVER 1000mm.

NOT RECOMMEND FOR USE ON TRANSOMS.

WHEN USING ON CURTAIN WALL FRAMES ENSURE FRAME IS FIXED LOCAL TO HINGES

SPW600e Casement

Folding Opener Preparation

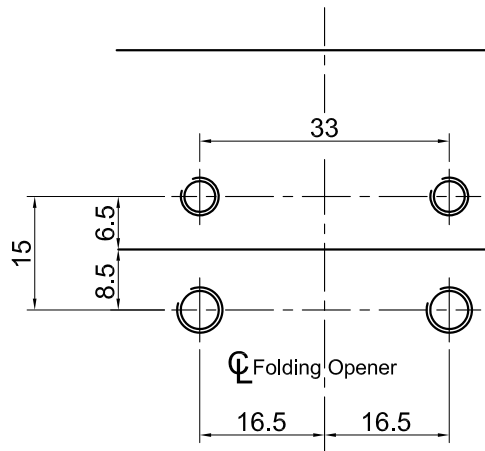
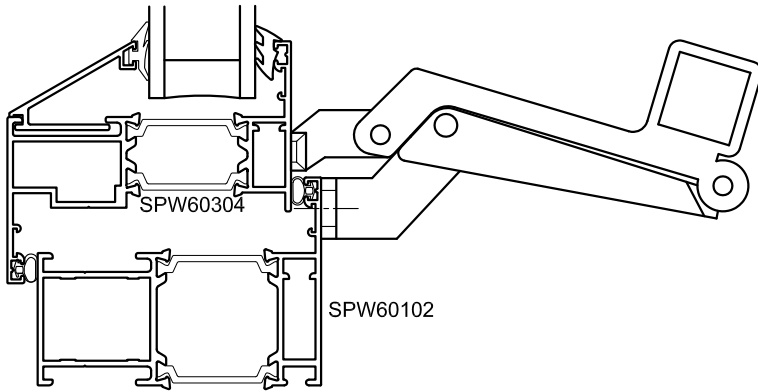

Fix Opener Using #8x3/8LG, Pozi Pan Hd, SFSPS41 With Ground Off Tip On Outer Frame Fixings.

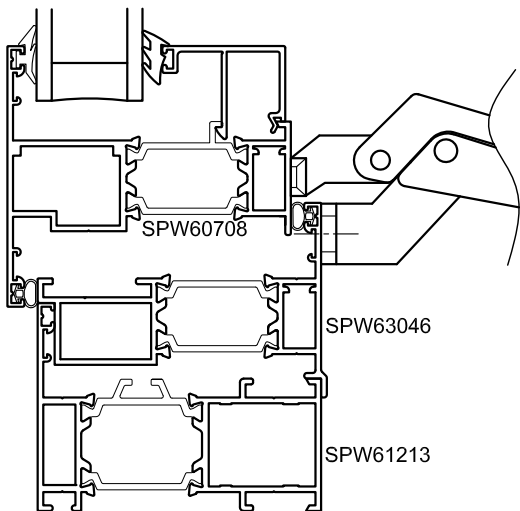

Single Folding Opener - Windows up to 900mm wide
 Double Folding Opener - Windows 900mm wide and above

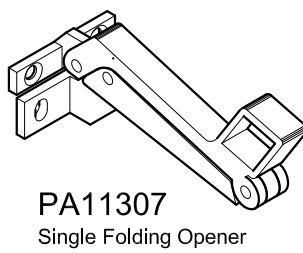

PA11307
Single Folding Opener

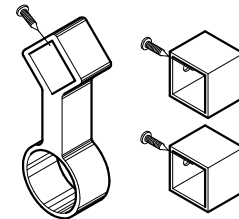

PA25152
Tandem Eye SAA
End Caps and Assembly Screws

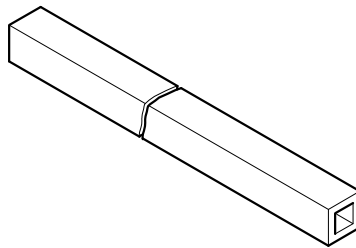

PA25042
Link Coupling 1000mm SAA
PA25032
Link Coupling 850mm SAA

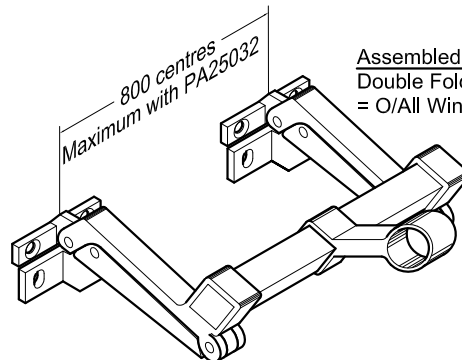
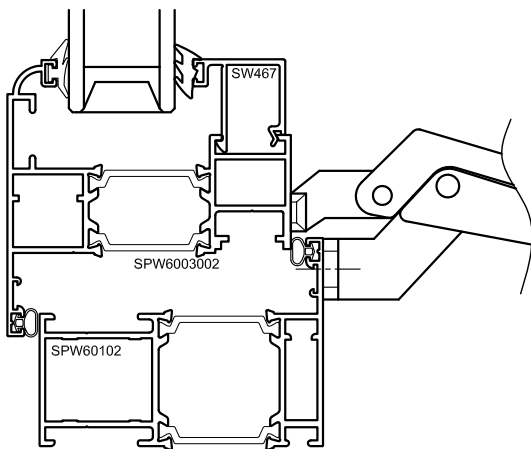

Assembled Double Folding Opener
 Double Folding Opener Centres
 = O/All Window Width/2

SPW600e Casement

SPW600e.E.110

Preparation - Espagnolette Locking

04.12

INLINEXX & SPIN9MM

Handle & 9mm Spindle
SEE SECTION "C" FOR HANDLE FINISHES

3 Nr. 10mm dia. holes for fixing location bushes on handle

Locking Point Keeps Ref: SW6ERK123M
Positioned to suit Mushroom Cams on Espagnolette Rod.

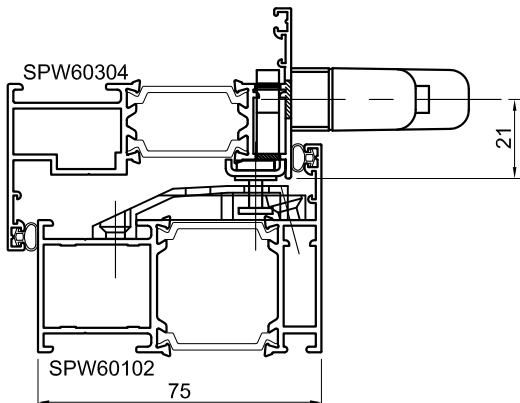
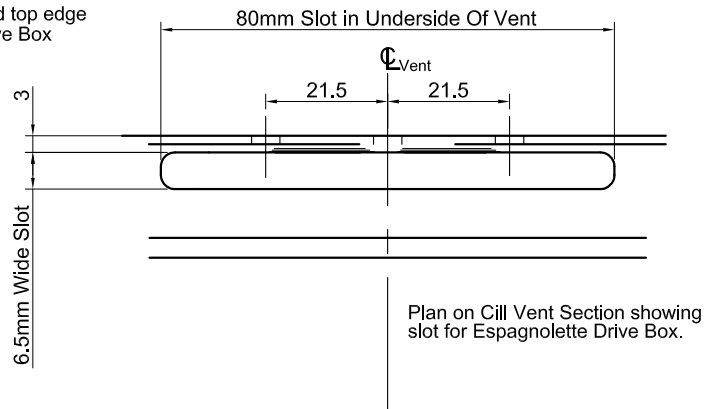
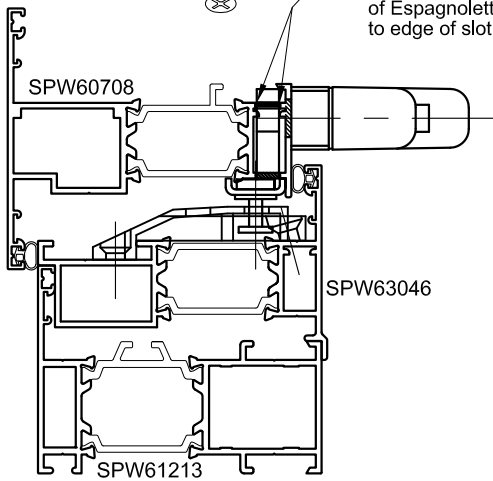
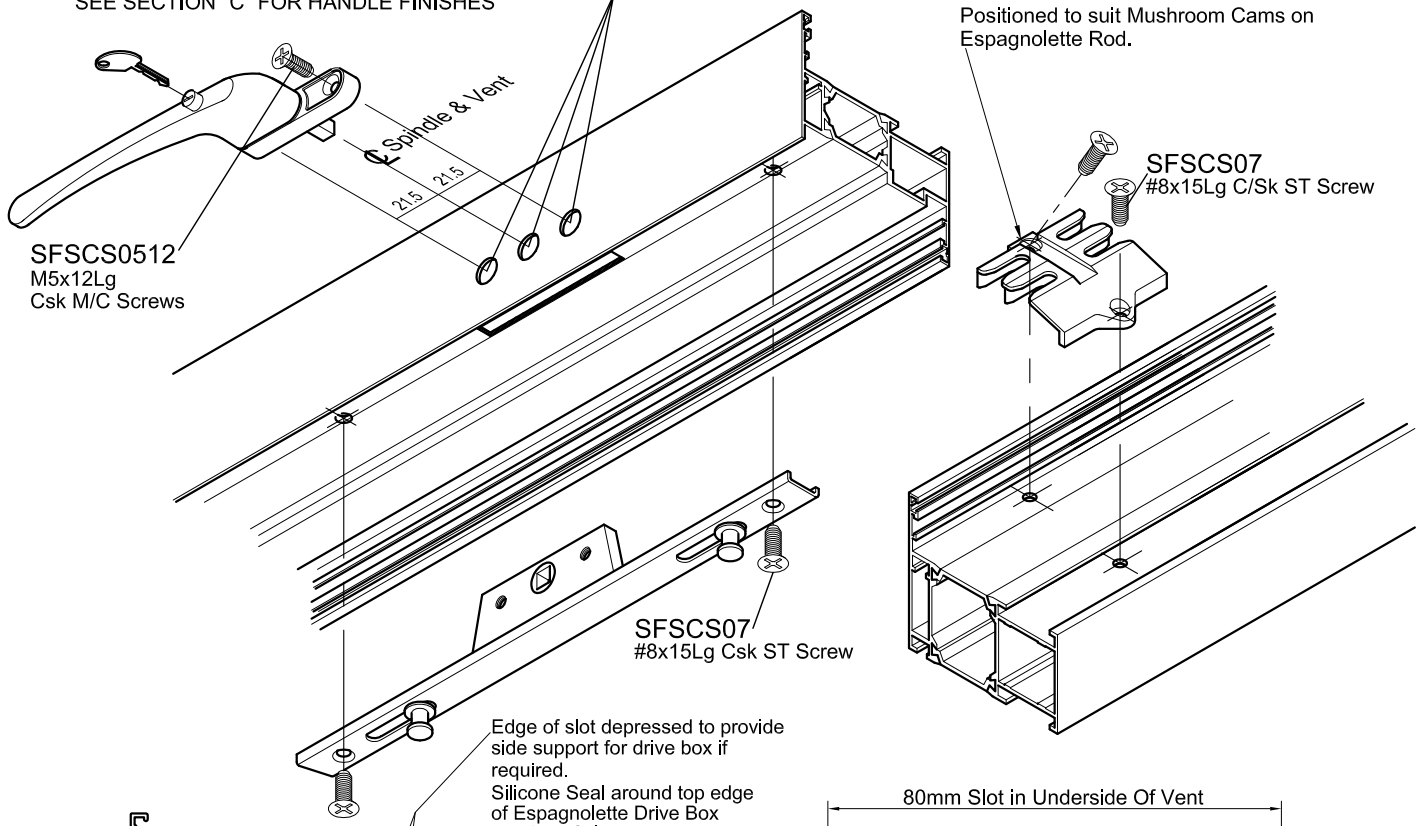

Espagnolette Rods				
Ref. No.	Length	Locking Points	Fixing Holes	Min. Vent Width To Suit Espag. Rod
SPW6E1	250mm	2	2	510mm
SPW6E2	400mm	2	4	660mm
SPW6E3	600mm	2	6	860mm
SPW6E4	800mm	2	6	1060mm
SPW6E5	1000mm	3	6	1260mm

ESPAGNOLETTE ROD - SEE CHART ABOVE FOR AVAILABLE SIZES.
ESPAGNOLETTE ROD TO BE USED TO MARK OUT FOR FIXING SCREWS.
SEE OUTER FRAME DETAIL FOR KEEPS.

SPW600e.E.111

06.13

SPW600e Casement

Cockspur Handle and Wedge Preparation Top or Side Hung Open Out Application

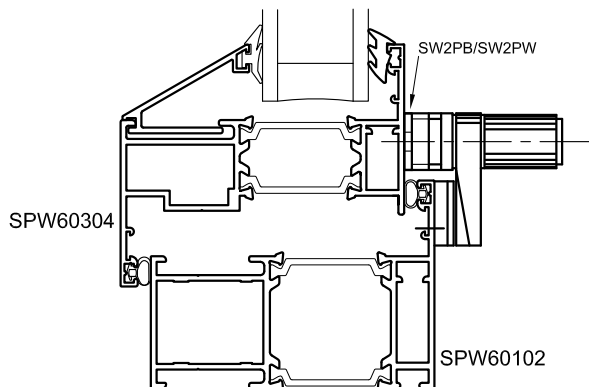
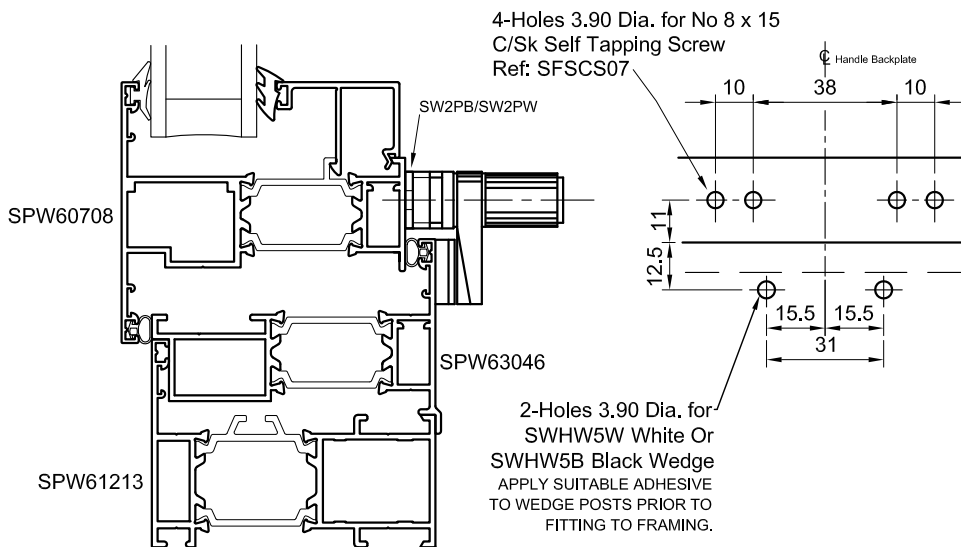
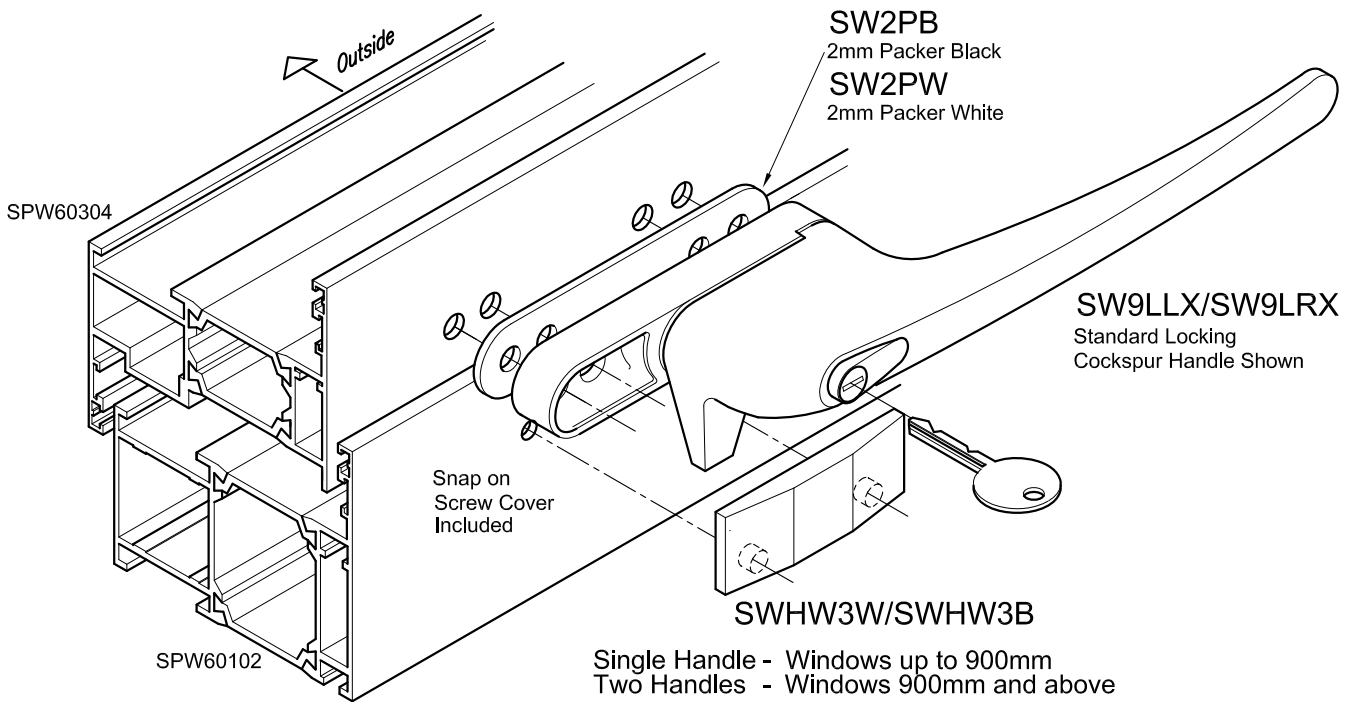

SPW600e Casement

SPW600e.E.112

Cockspur Handle and Wedge Preparation
Top or Side Hung Open Out Application

06.13

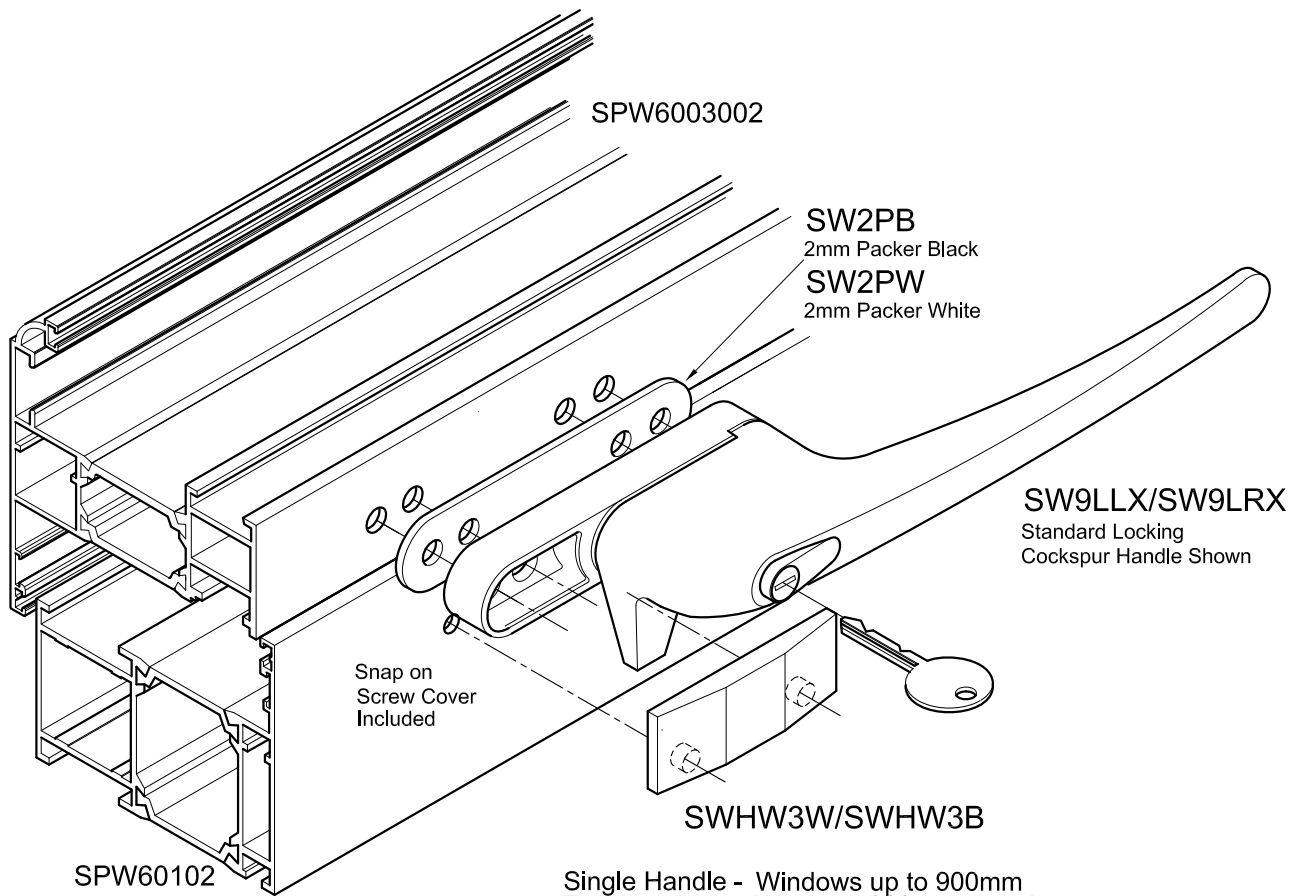

Single Handle - Windows up to 900mm
Two Handles - Windows 900mm and above

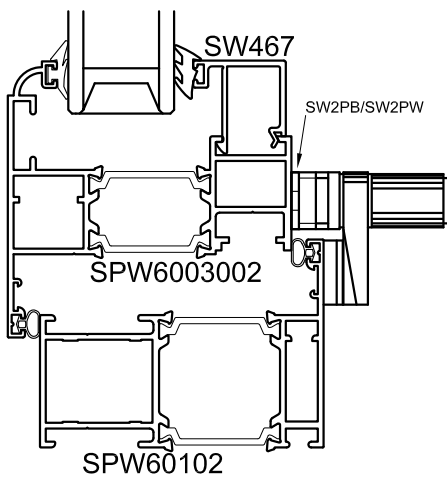

4-Holes 3.90 Dia. for No 8 x 15
C/Sk Self Tapping Screw
Ref: SFSCS07

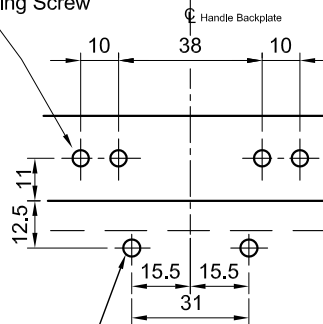

2-Holes 3.90 Dia. for
SWHW5W White Or
SWHW5B Black Wedge
APPLY SUITABLE ADHESIVE
TO WEDGE POSTS PRIOR TO
FITTING TO FRAMING.

SPW600e.E.113

04.12

SPW600e Casement

Shootbolt Espagnolette Preparation - SPW68693 Sash

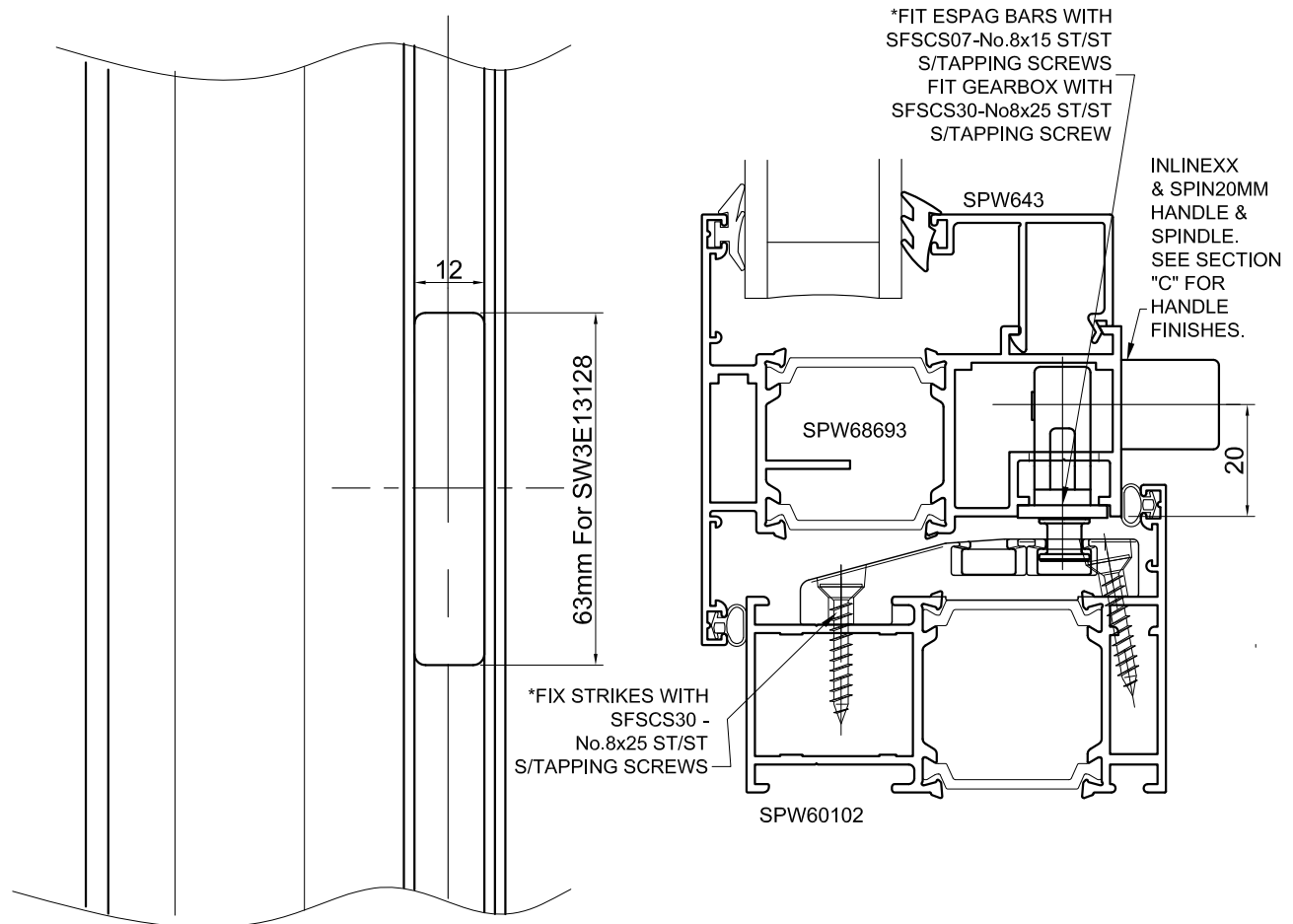
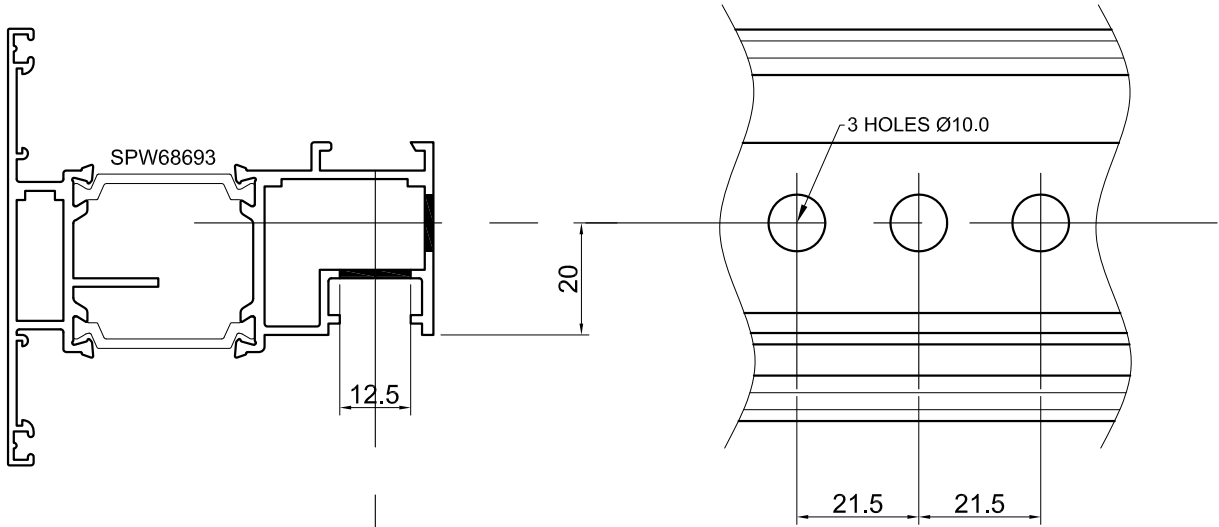

SPW600e Casement

SPW600e.E.114

Shootbolt Espagnolette Preparation - SPW6003002

04.12

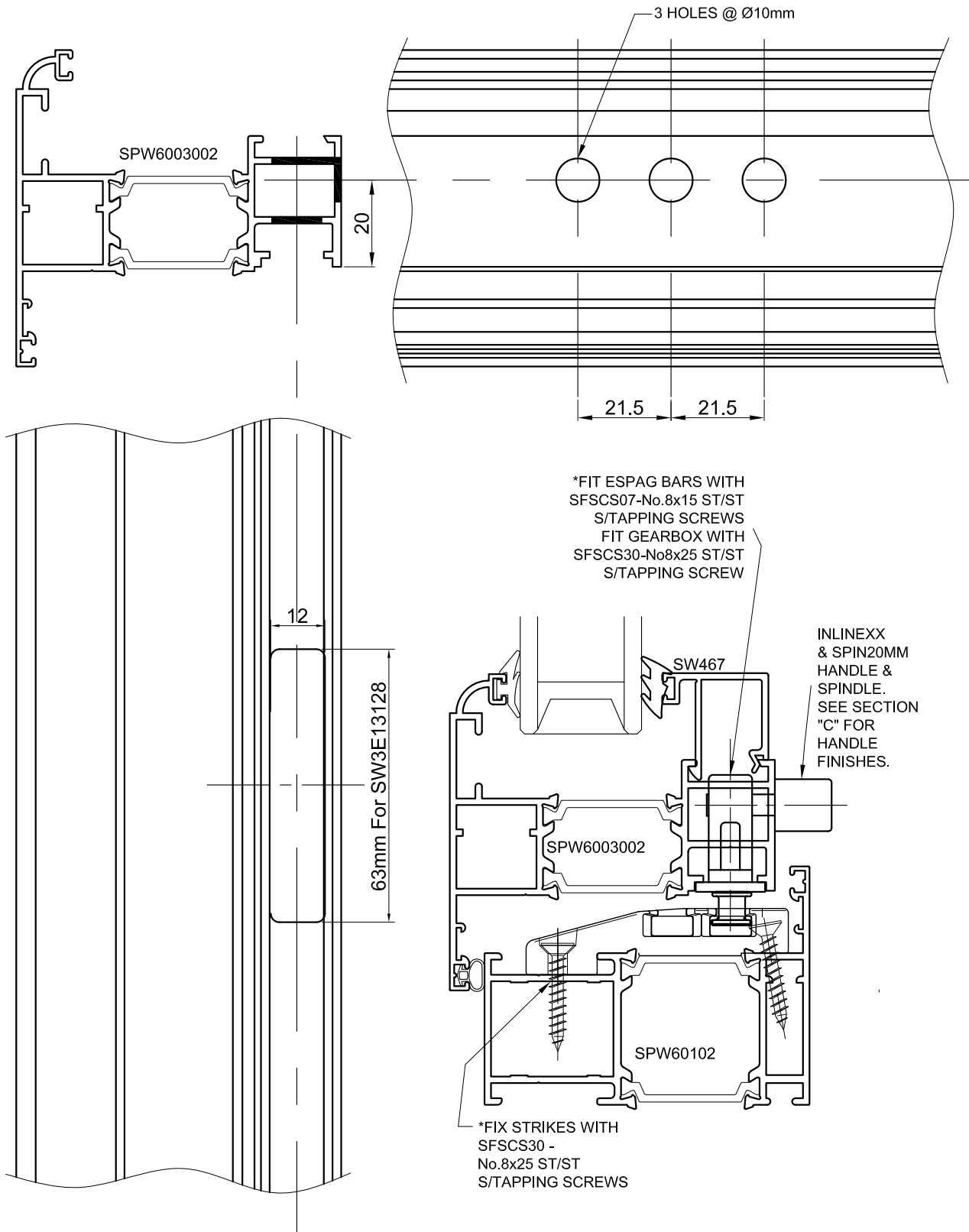

Shootbolt Espagnolette Preparation/Assembly

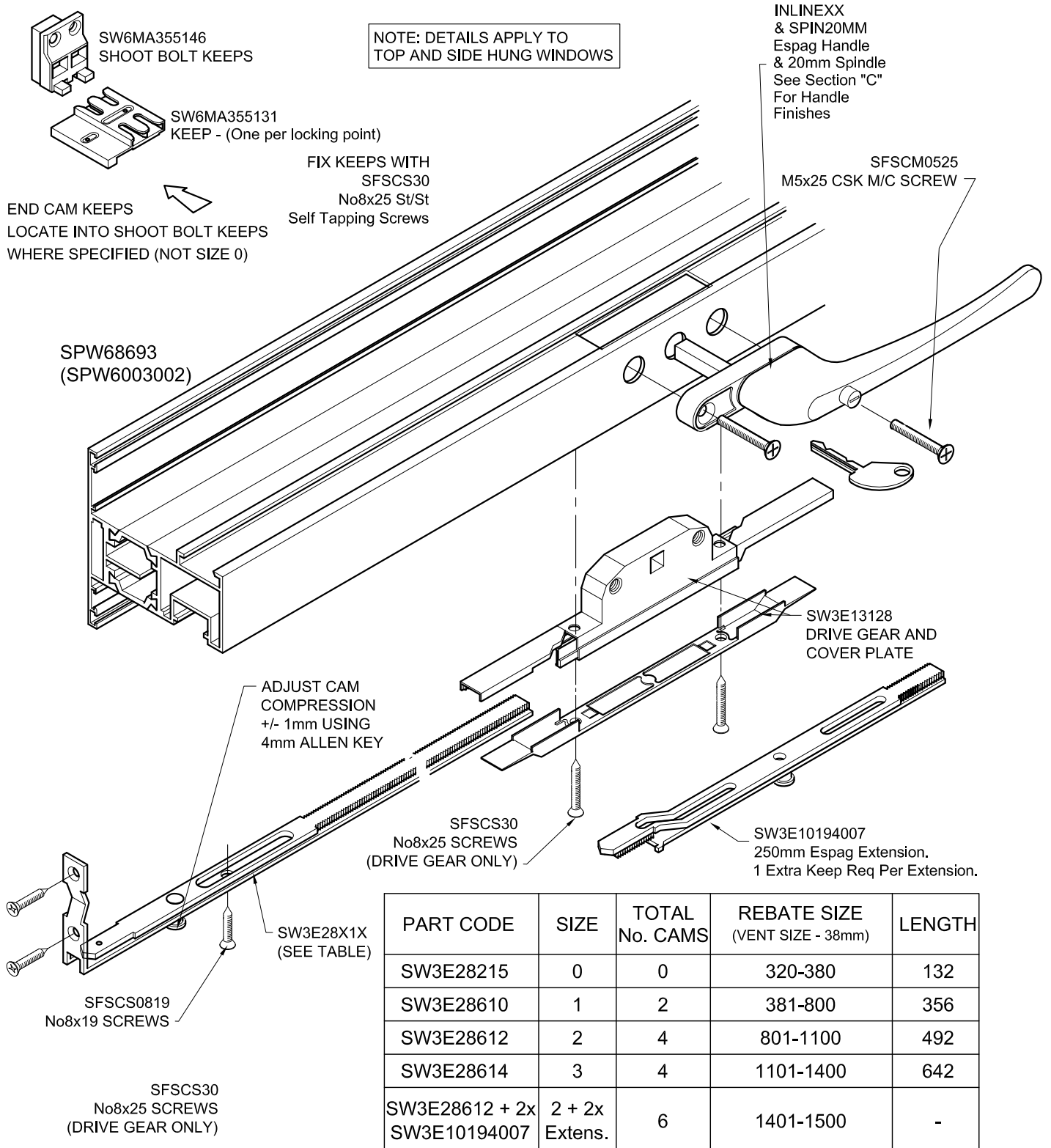

NOTE - MAXIMUM WIDTH OF TOP HUNG VENT IS 1500mm
 - MAXIMUM HEIGHT OF SIDE HUNG VENT IS 1500mm
 - MIN RECOMMENDED SIZE = 358mm

THE BOLT THROW IS ADJUSTED
 BY MOVING THE MUSHROOM BOLT
 SET TO 10 BEFORE CROPPING

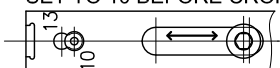

LOCATE THE EXTENSION INTO THE CORNER
 OF THE SASH AND CROP TO SIZE



SPW600e Casement

Blank

SPW600e.E.116

04.12

This Page is Intentionally Left Blank

SPW600e.E.117

04.12

SPW600e Casement

Hinge Protectors - SPW68693 Sash

Fix Two Sets Per Window, Both 100mm From Corners As Shown Below.

Fix HCMA353309SC With SFSCS03 No.8 x 12mm.

Fix HCMA356366SC With SFSCS29 No.8 x 25mm.

Fix HCMA359086SC With SFSCS03 No.8 x 12mm.

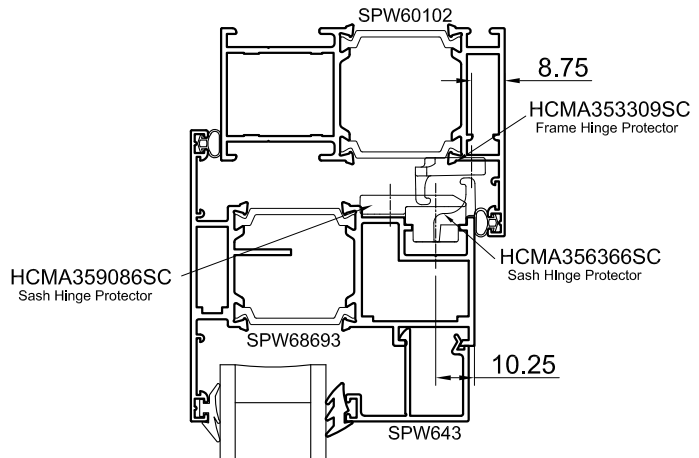

HCMA353309SC
Frame Hinge Protector

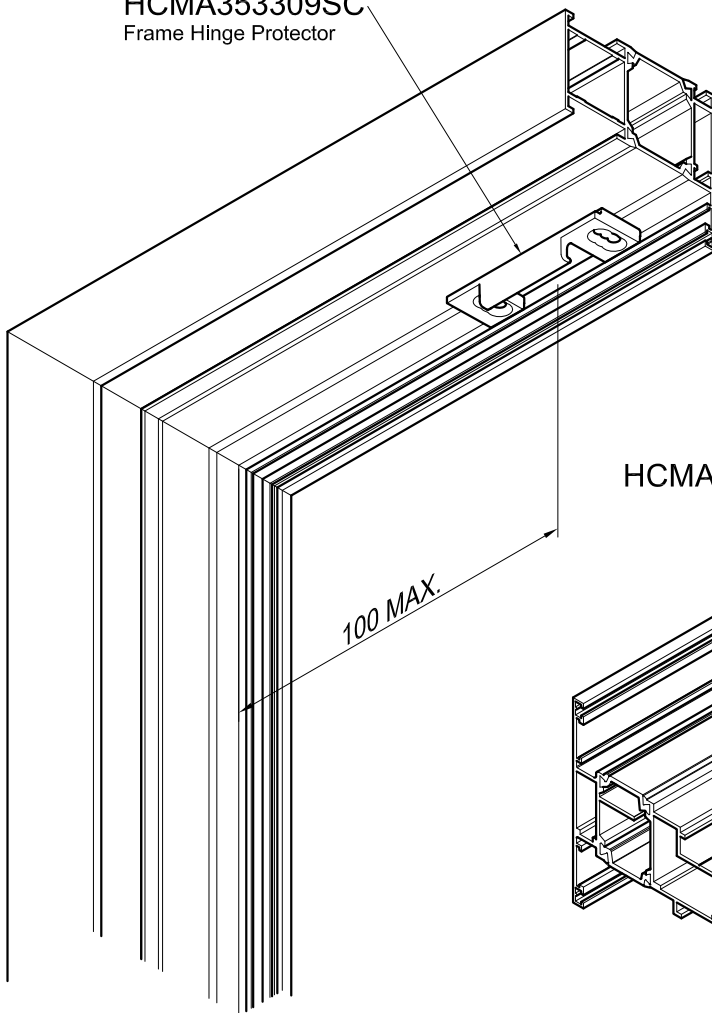

HCMA356366SC
Sash Hinge Protector

HCMA359086SC
Stabilizer Stay

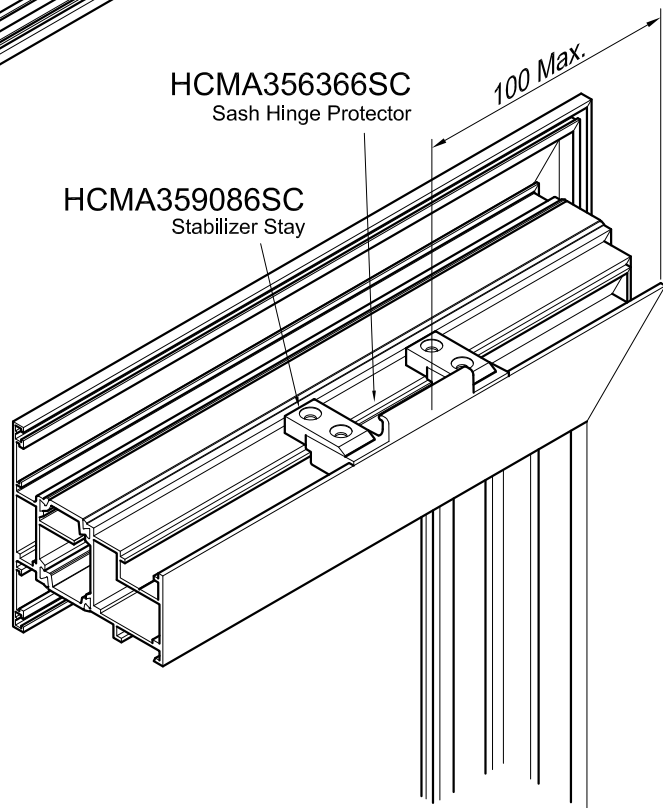

SPW600e Casement

Hinge Protectors - SPW6003002 Sash

SPW600e.E.118

04.12

Fix Two Sets Per Window, Both
100mm From Corners As Shown
Below.

Fix HCMA353309SC With
SFSCS03 No.8 x 12mm.

Fix HCMA356366SC With
SFSCS29 No.8 x 25mm.

Fix HCMA359086SC With
SFSCS03 No.8 x 12mm.

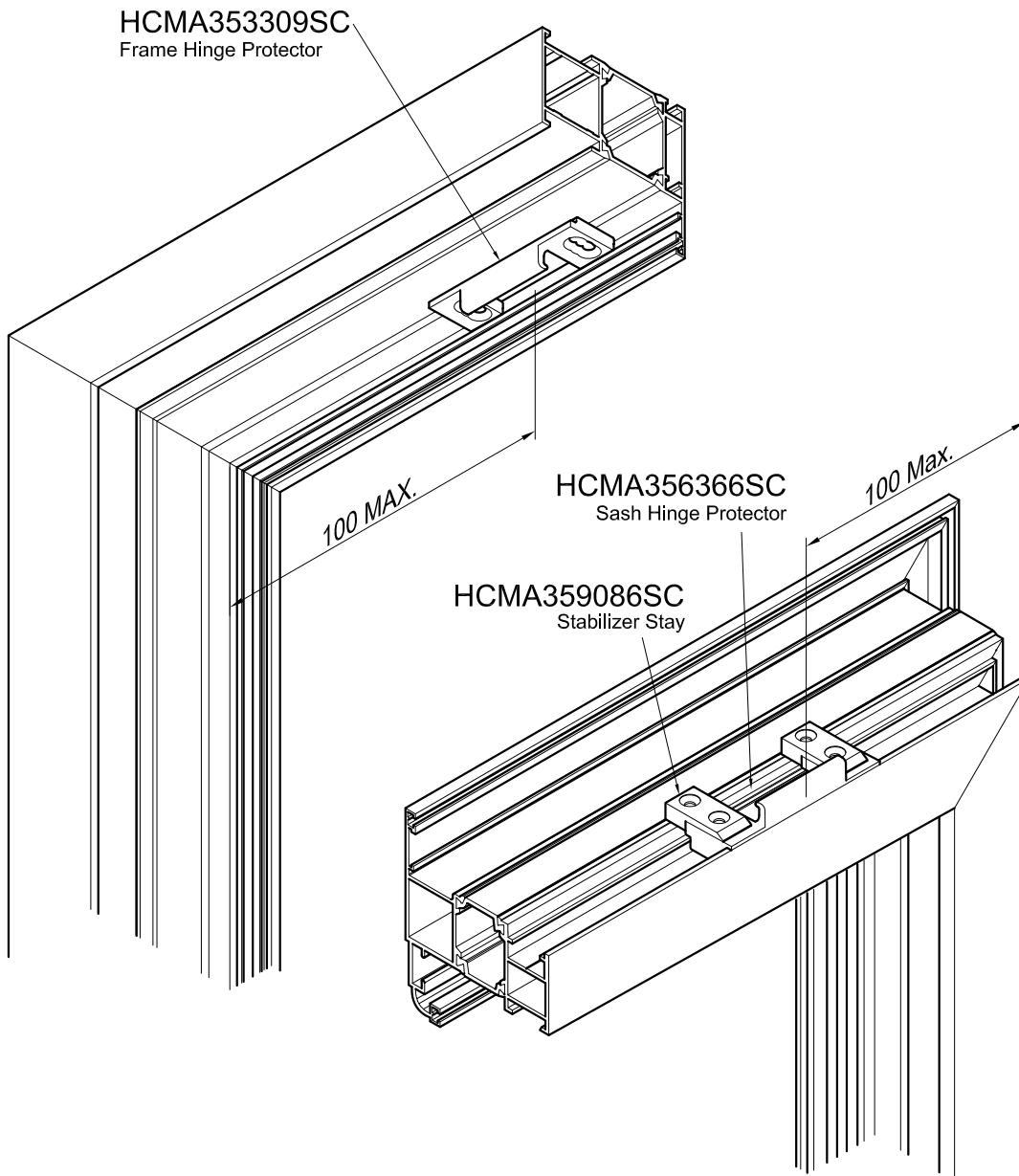
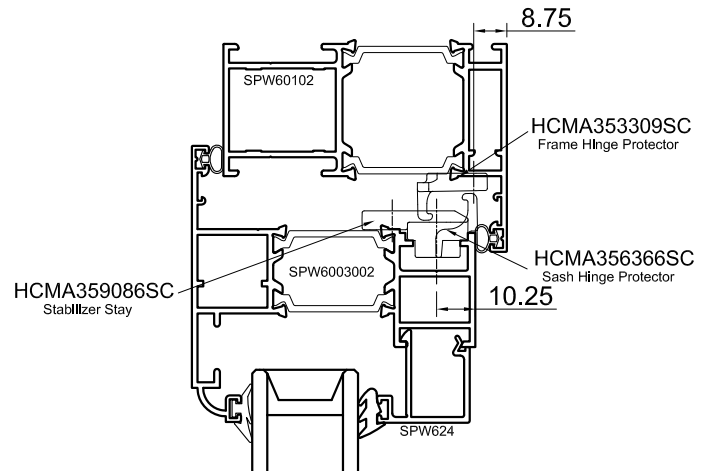

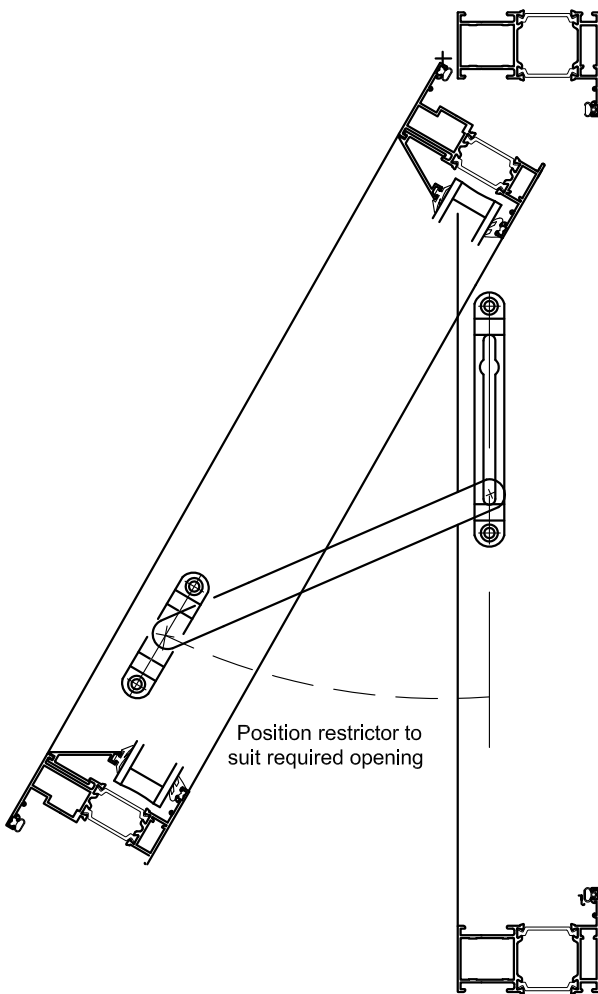
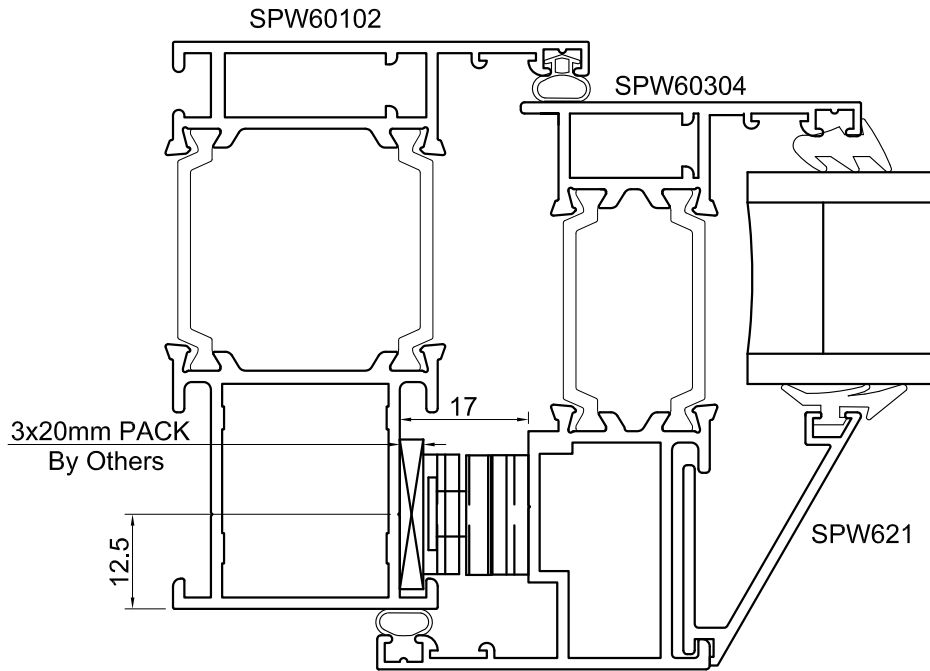

C/sk holes suitable to receive
No 8 x 12 c/sk s/steel
self tapping screw.
Ref: SFSCS03

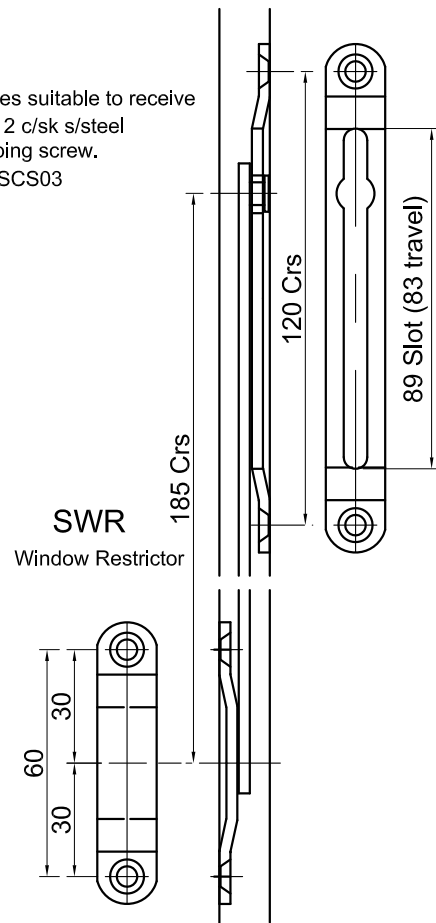

SPW600e Casement

SPW600e.E.120

Foam Selection & Insertion - In Section

04.12

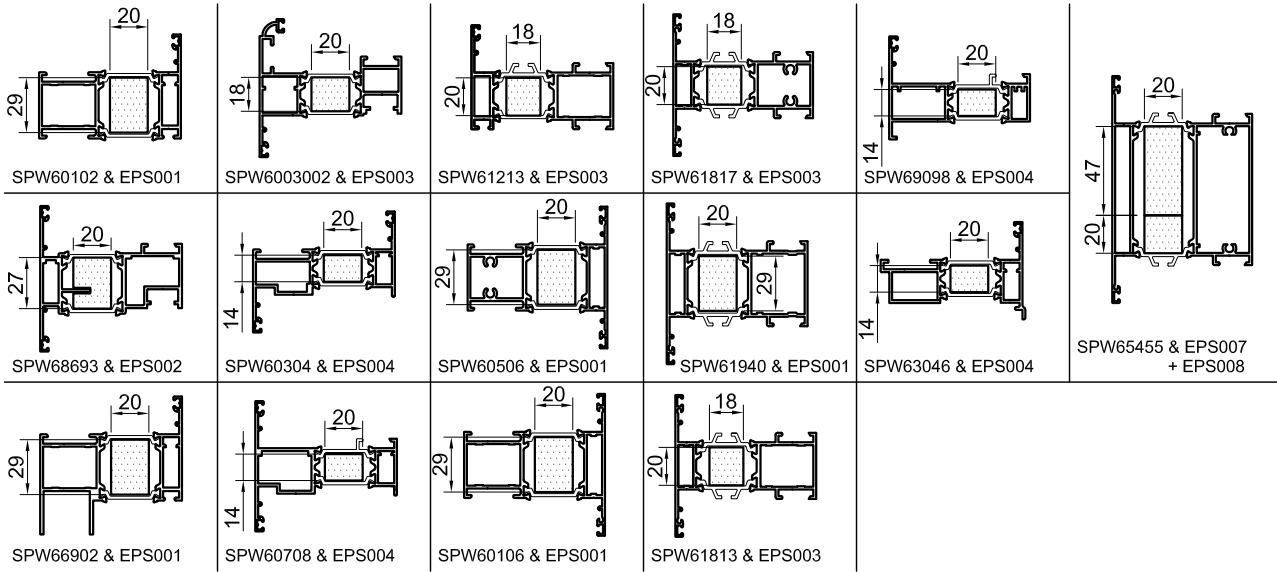

Push Foam Into Sections Thermal Break
Cavity Before Crimping Corners.
If Foam Section Isn't Long Enough Butt
Up With Same Insert.

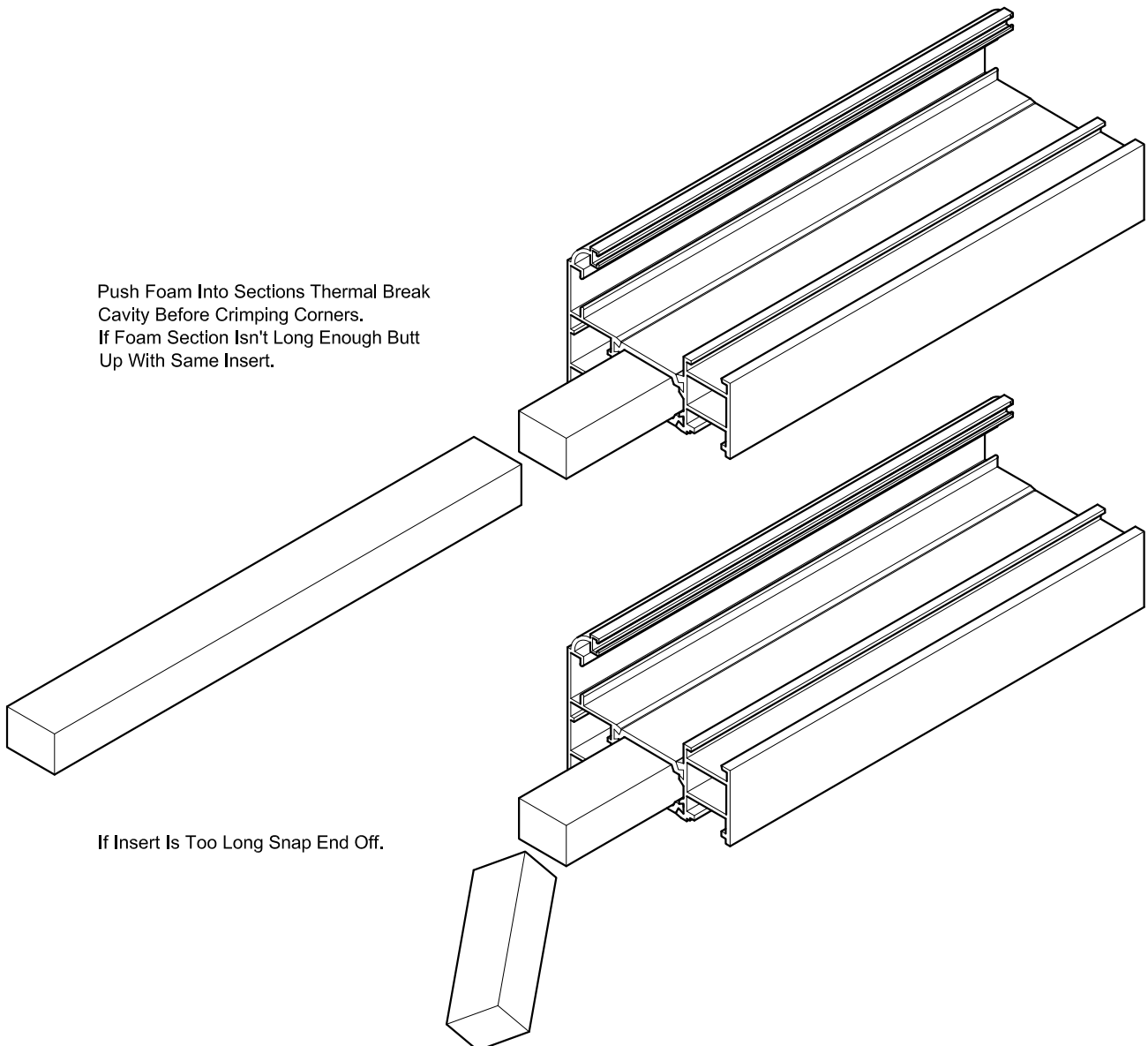

Foam Selection & Insertion - Under Glass

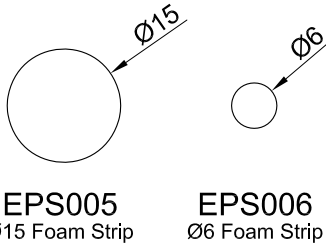
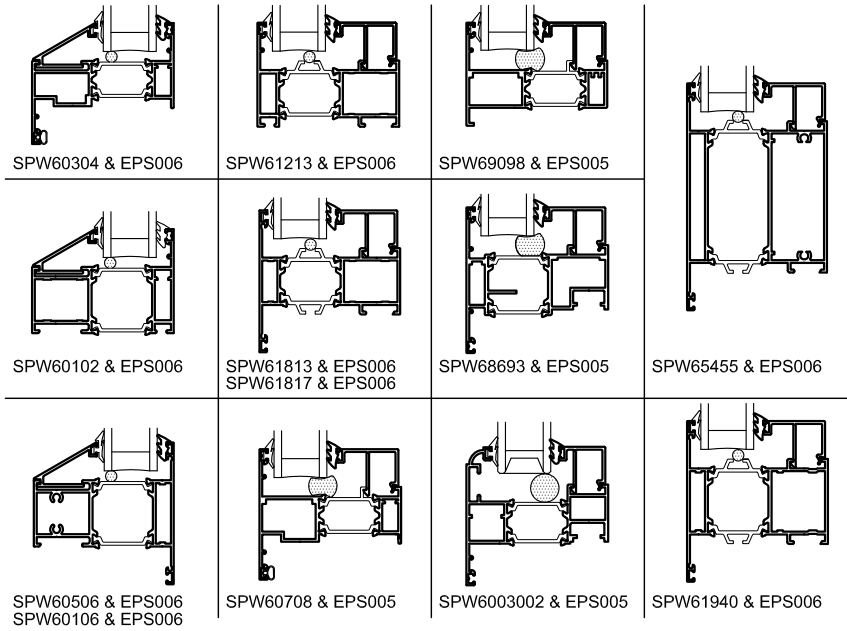

Insert Gasket Into Rebate, Fit And Pack Glass Accordingly.
 Push Round EPS Insert Between Glass & Frame.
 Cut Between Glass Packs & Feed Round Corners.
 When This is Done Fit Beads.

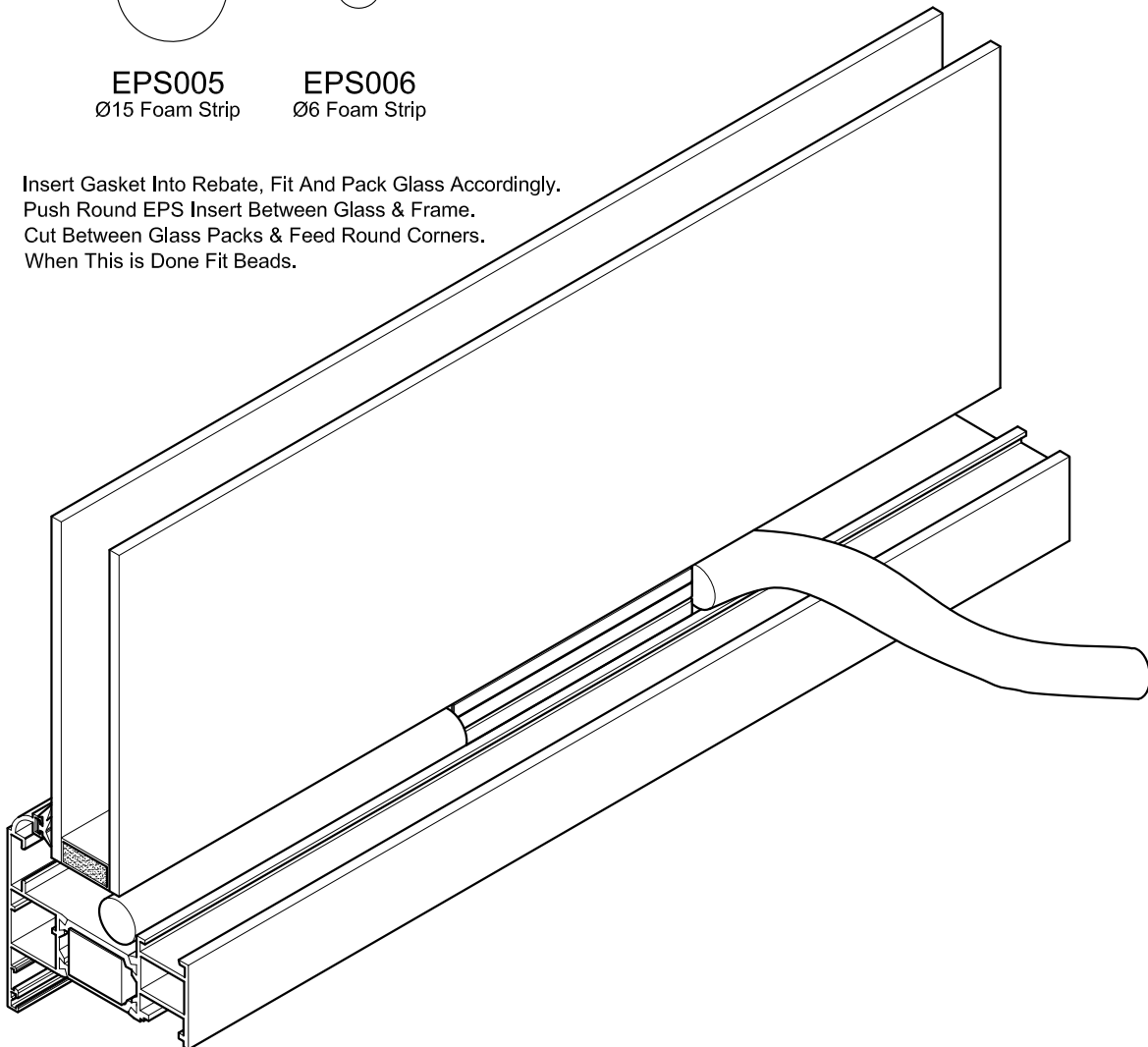

This Page is Intentionally Left Blank

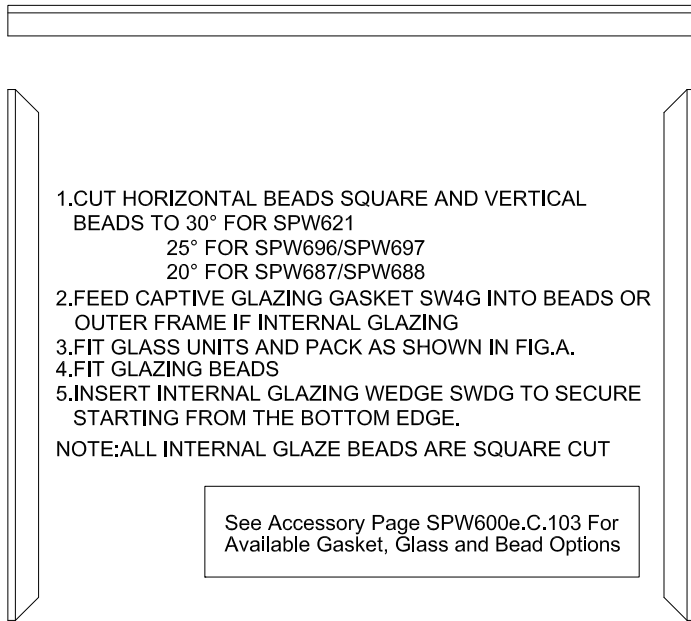
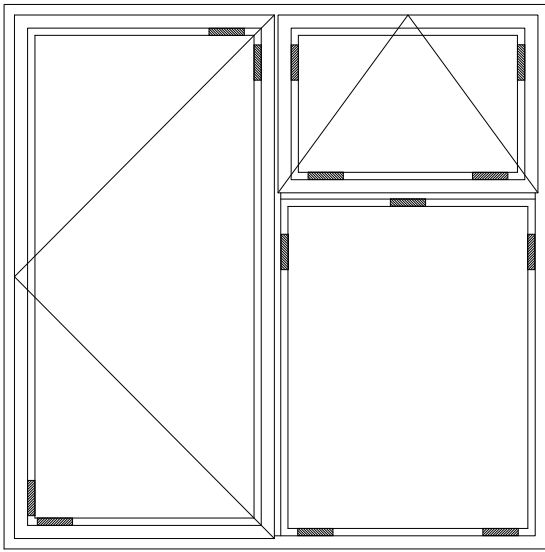
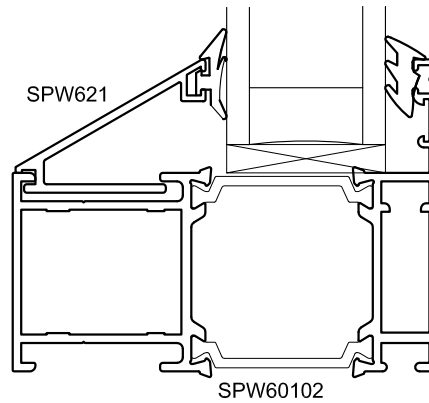
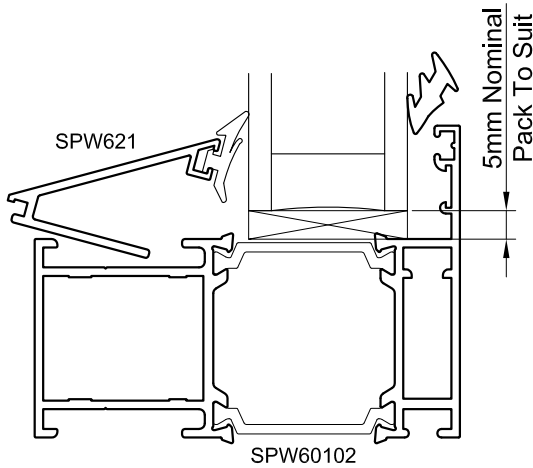

FIGURE A - CONVENTIONAL GLASS PACKING

FIGURE B - BEAD CUTTING



External Glazing

Support Packer
18 x 5mm THICK
SGP18x5

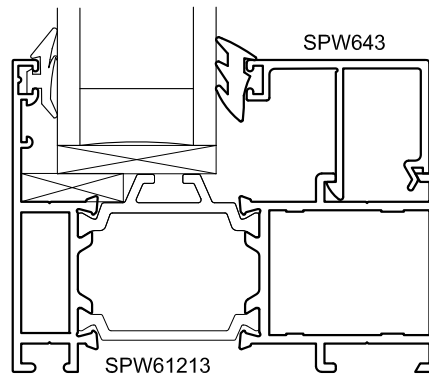
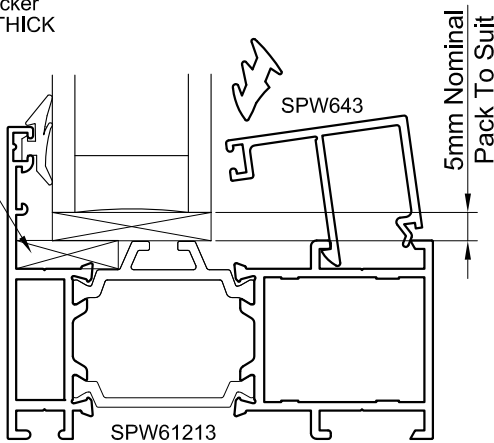

Internal Glazing

SPW600e Casement

SPW600e.F.102

Glazing

04.12

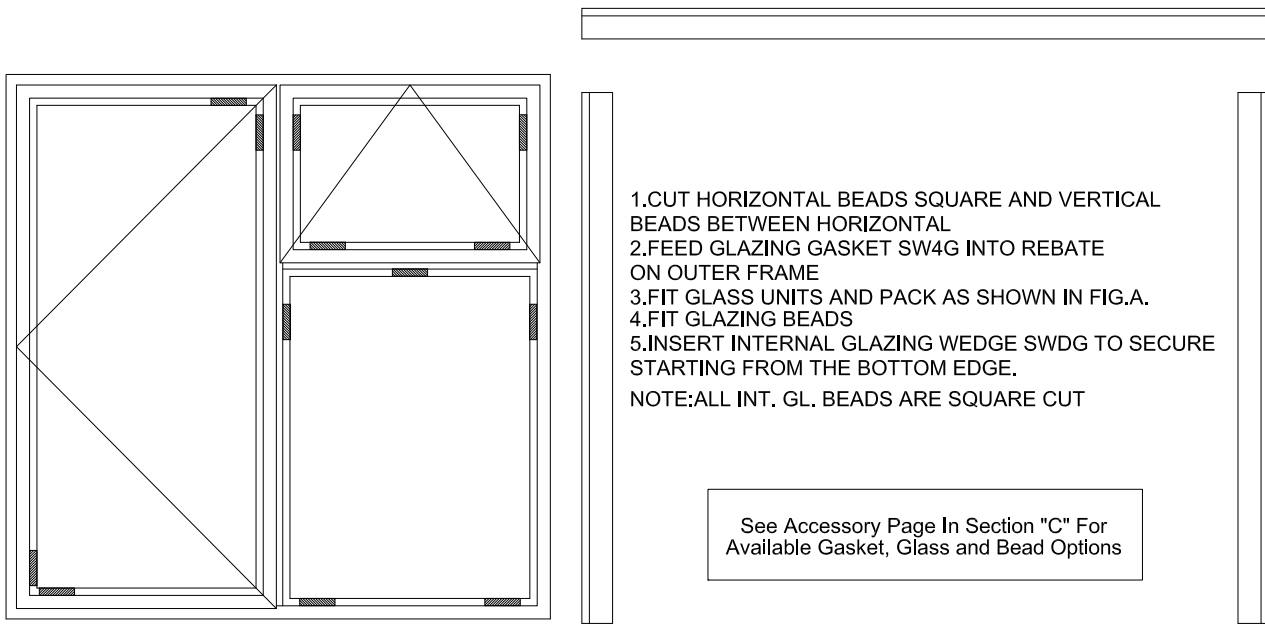

FIGURE A - CONVENTIONAL GLASS PACKING

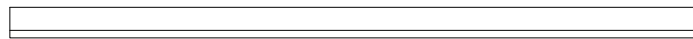
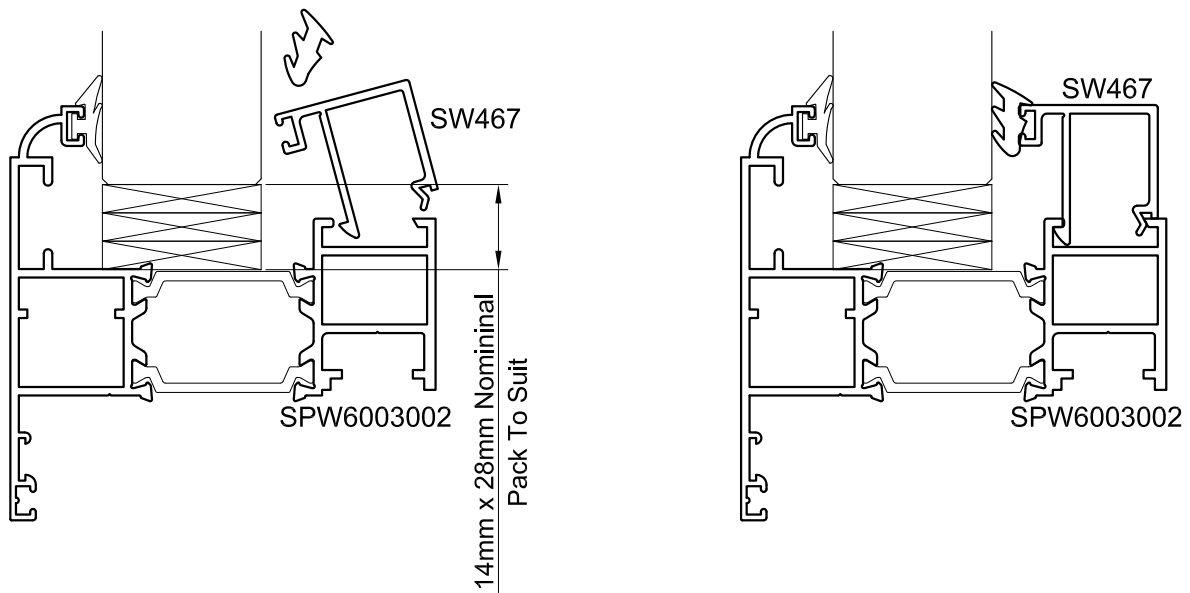
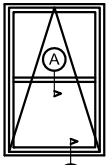

FIGURE B - BEAD CUTTING





Key

NOTE: LEAVE A 1MM GAP AT ALL JOINTS FOR EXPANSION. GLASS & BAR MUST BE CLEANED USING ANY INDUSTRIAL METHYLATED SPIRIT BEFORE APPLICATION. APPLY WITH A LINT FREE CLOTH. WHITE SPIRIT MUST NOT BE USED AS IT WILL AFFECT ADHESION.

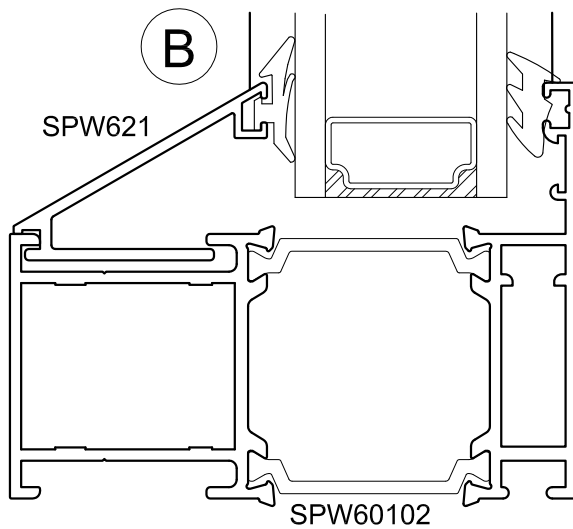
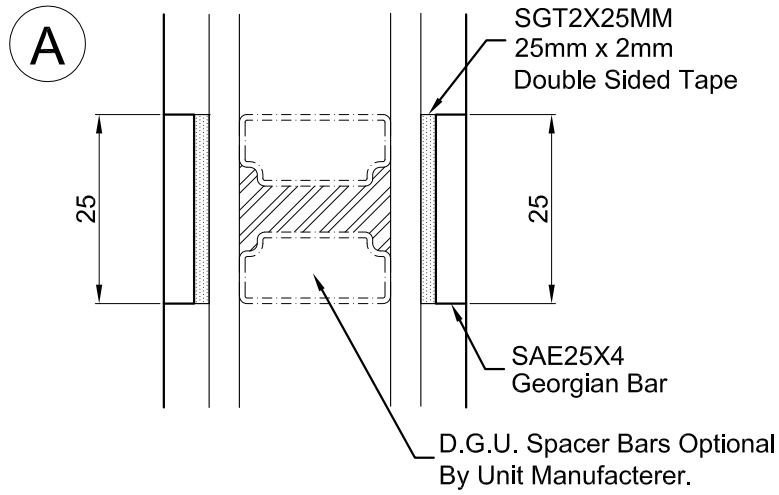

SPW600e Casement

SPW600e.F.104

Glazing - Georgian Bar Details

04.12

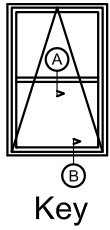

NOTE: LEAVE A 1MM GAP AT ALL JOINTS FOR EXPANSION. GLASS & BAR MUST BE CLEANED USING ANY INDUSTRIAL METHYLATED SPIRIT BEFORE APPLICATION. APPLY WITH A LINT FREE CLOTH. WHITE SPIRIT MUST NOT BE USED AS IT WILL AFFECT ADHESION.

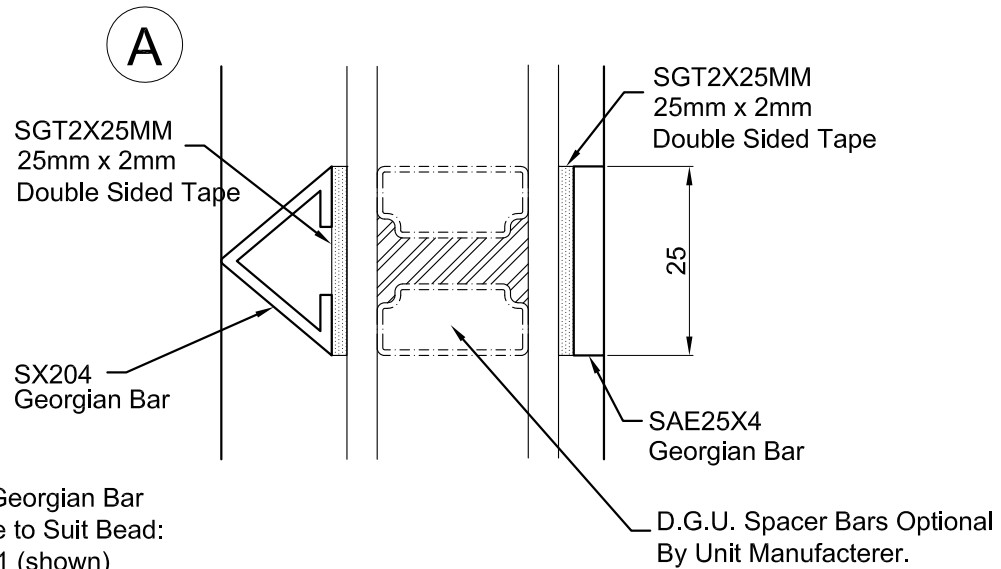

Scribe Georgian Bar
At Angle to Suit Bead:
SPW621 (shown)
SPW696 & SPW697 = 25°
SPW687 & SPW688 = 20°

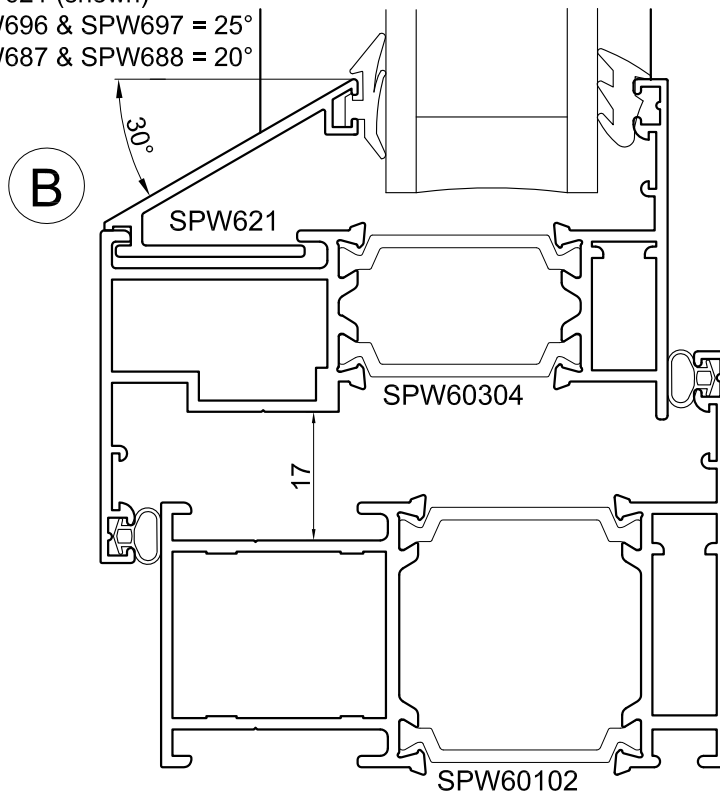

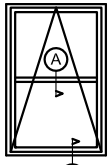

Key

NOTE: LEAVE A 1MM GAP AT ALL JOINTS FOR EXPANSION. GLASS & BAR MUST BE CLEANED USING ANY INDUSTRIAL METHYLATED SPIRIT BEFORE APPLICATION. APPLY WITH A LINT FREE CLOT. WHITE SPIRIT MUST NOT BE USED AS IT WILL AFFECT ADHESION.

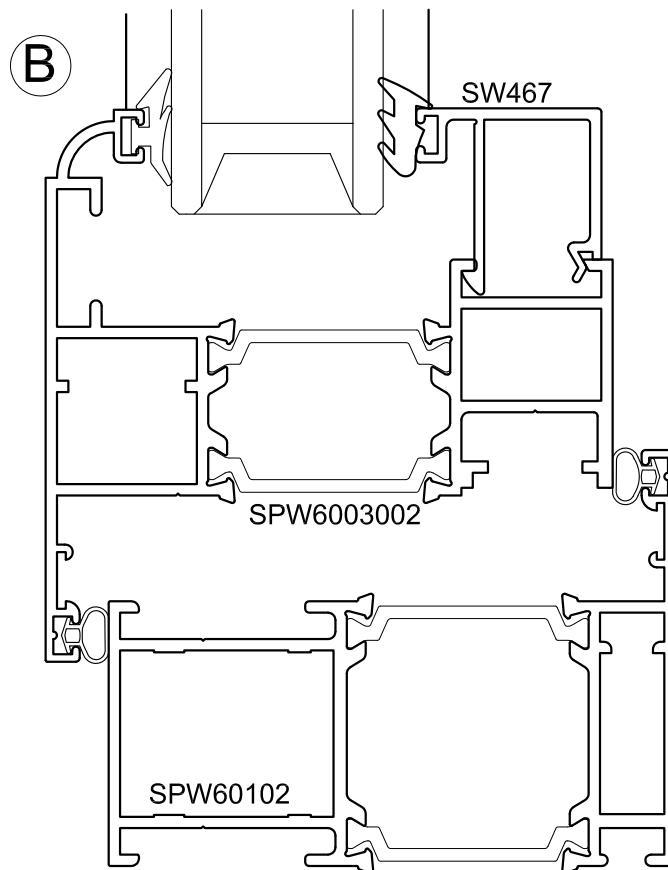
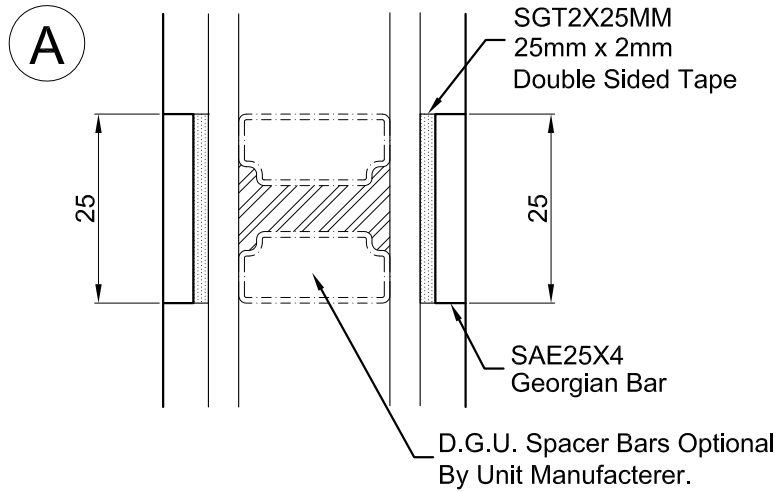

SPW600e Casement

Glazing - Georgian Bar Cruciform

SPW600e.F.106

04.12

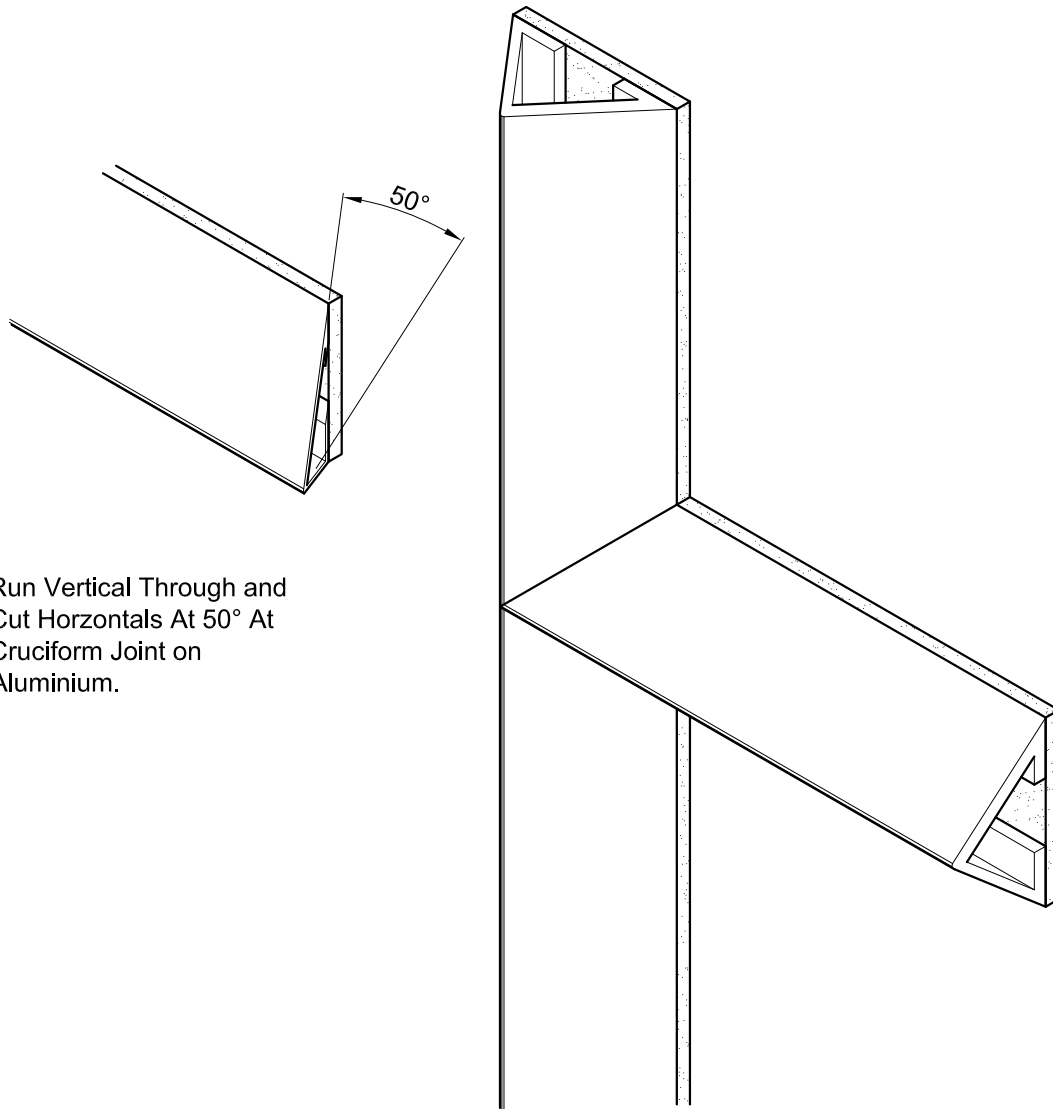

Run Vertical Through and
Cut Horizontals At 50° At
Cruciform Joint on
Aluminium.

NOTE: THIS BAR CAN ONLY BE USED WITH EXTERNAL GLAZING BEADS.
LEAVE A 1MM GAP AT ALL JOINTS FOR EXPANSION. GLASS & BAR
MUST BE CLEANED USING ANY INDUSTRIAL METHYLATED SPIRIT
BEFORE APPLICATION. APPLY WITH A LINT FREE CLOTH. WHITE
SPIRIT MUST NOT BE USED AS IT WILL AFFECT ADHESION.

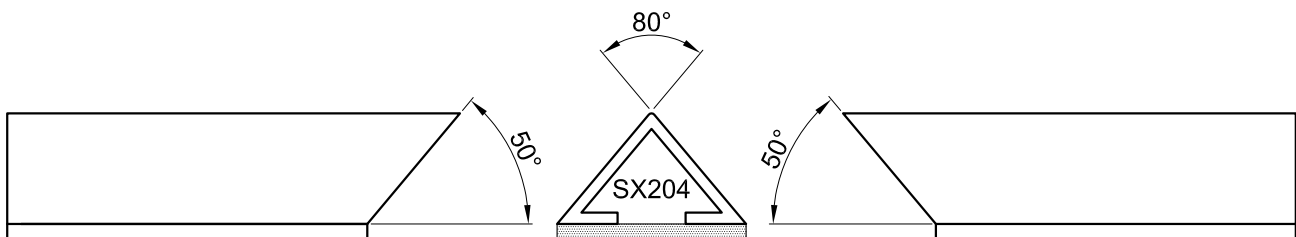

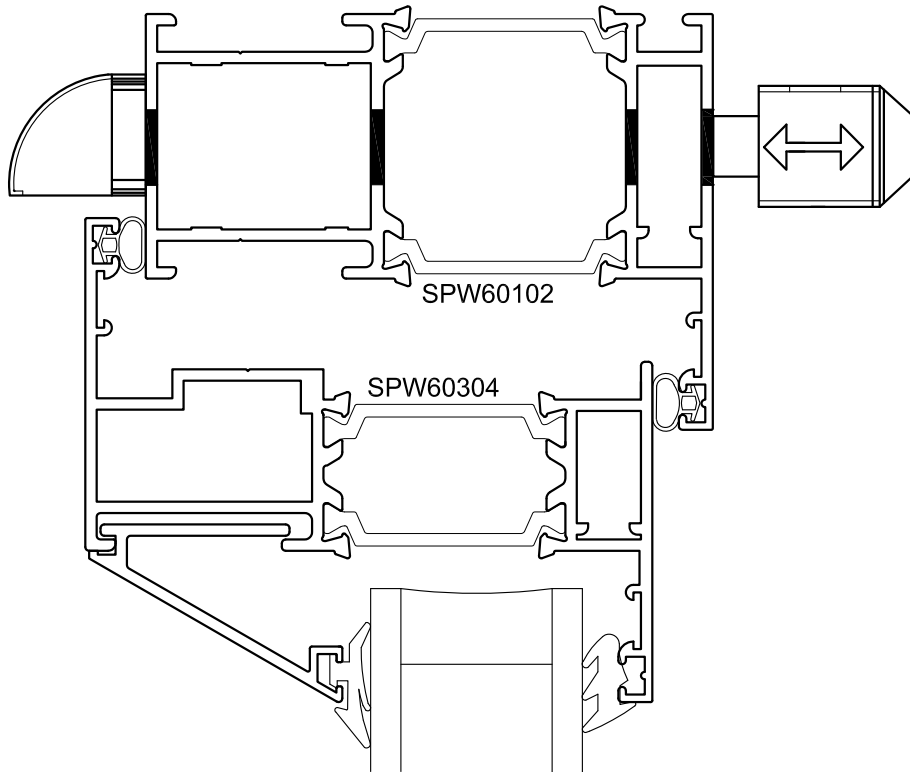
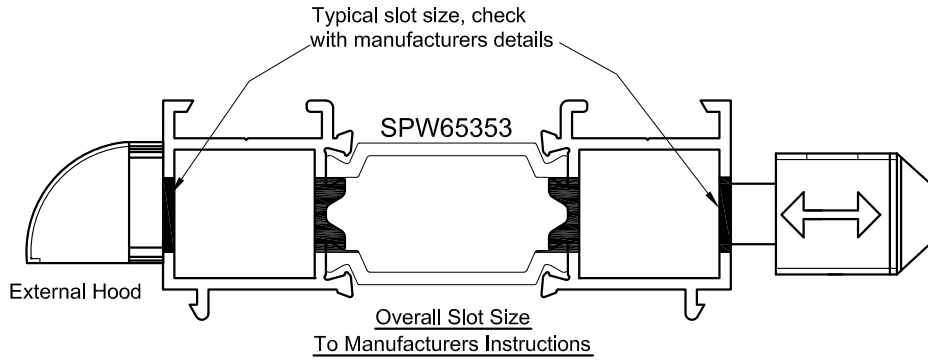

Typical Detail

SPW600e Casement

28mm Over Glass Trickle Vent Detail

SPW600e.G.102

04.12

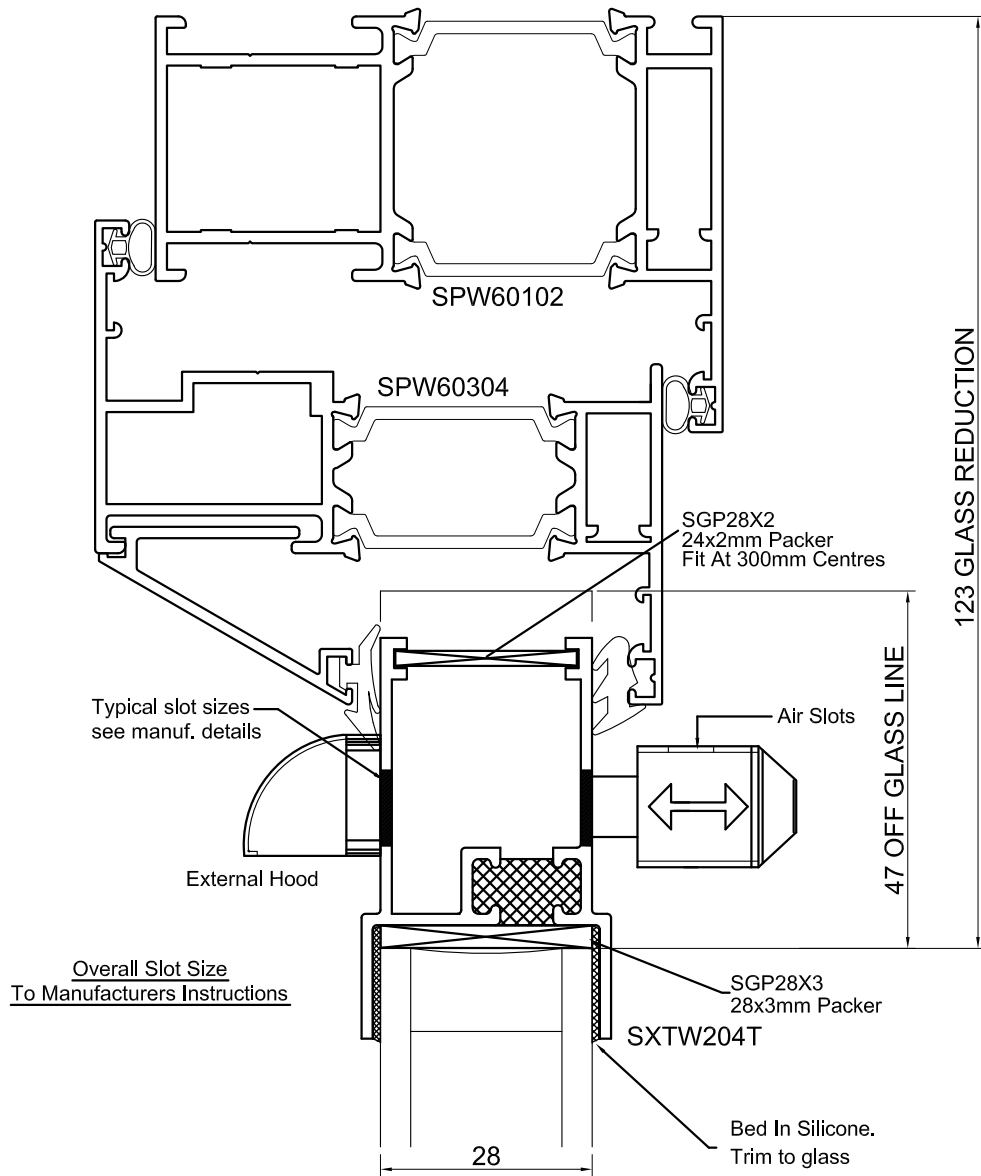

Typical Detail

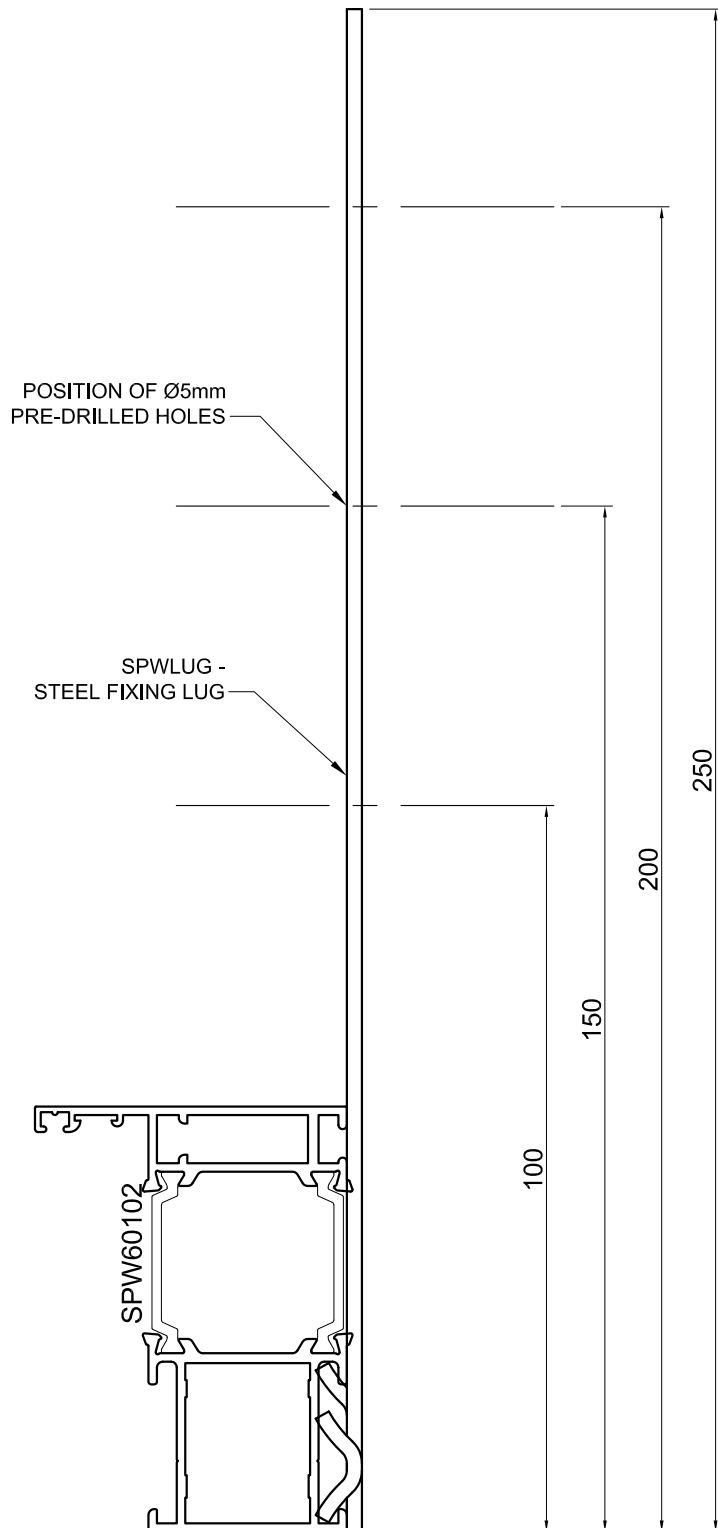

SPW600e Casement

25mm Add-On & Weather Bar

SPW600e.G.104

04.12

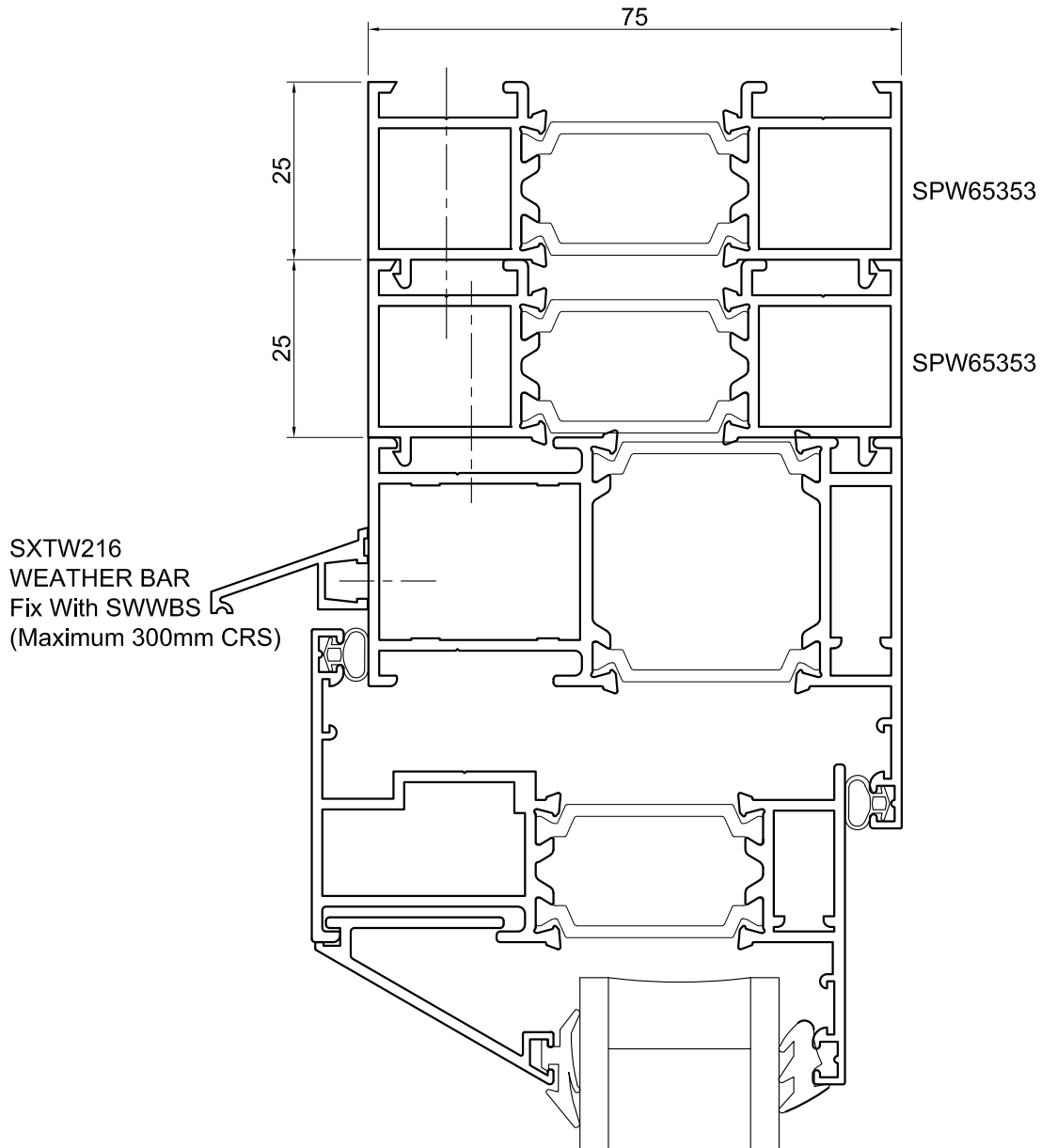

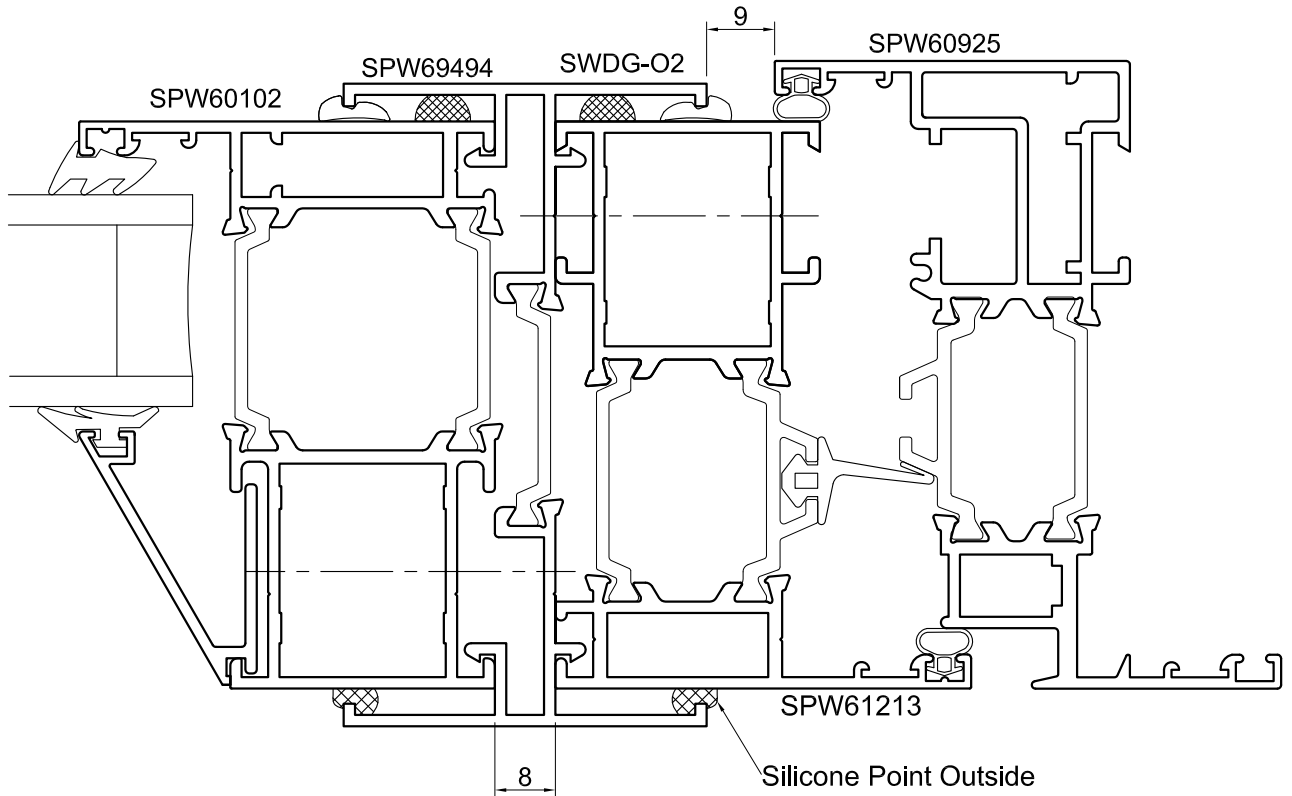
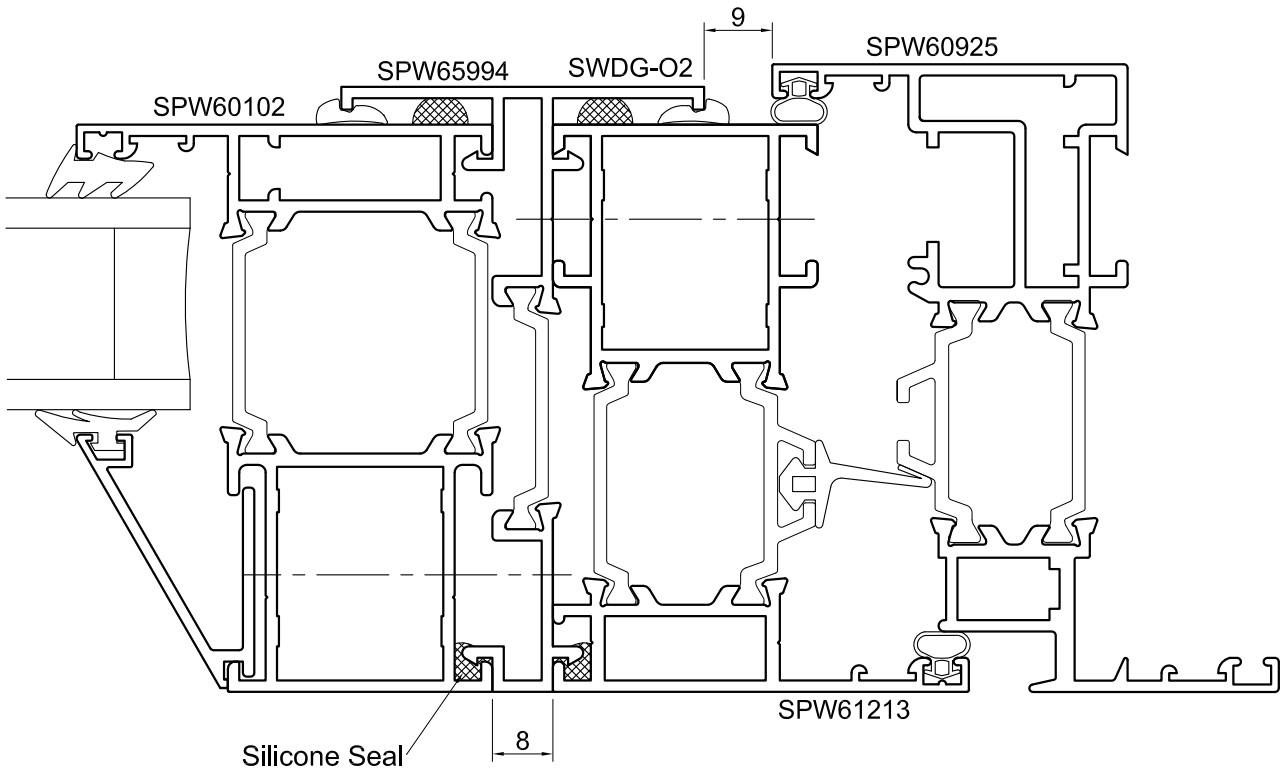

SPW600e Casement

Coupler & Reinforced Coupler

SPW600e.G.106

04.12

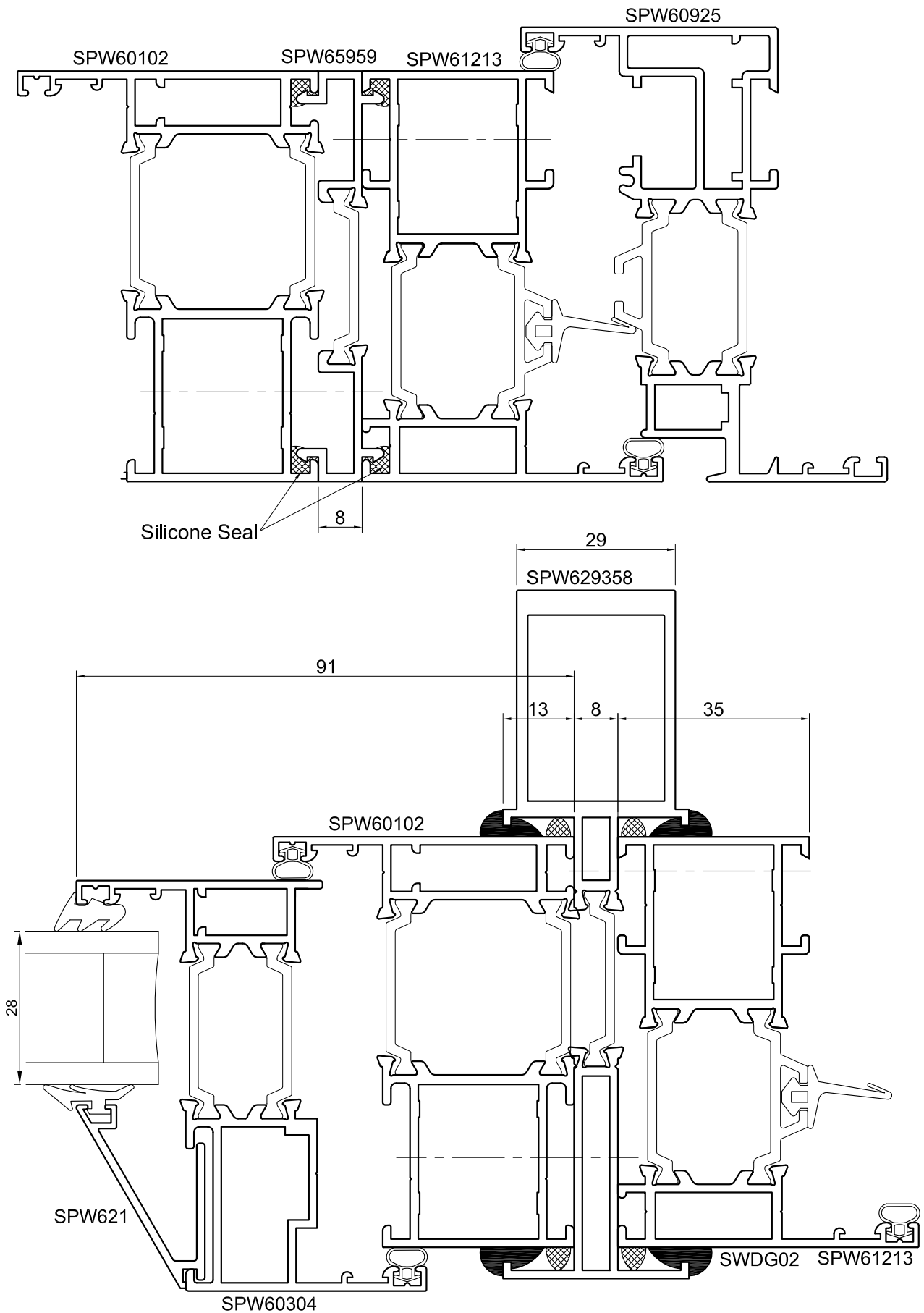

SPW600e Casement

SPW600 To SPW300 Coupling

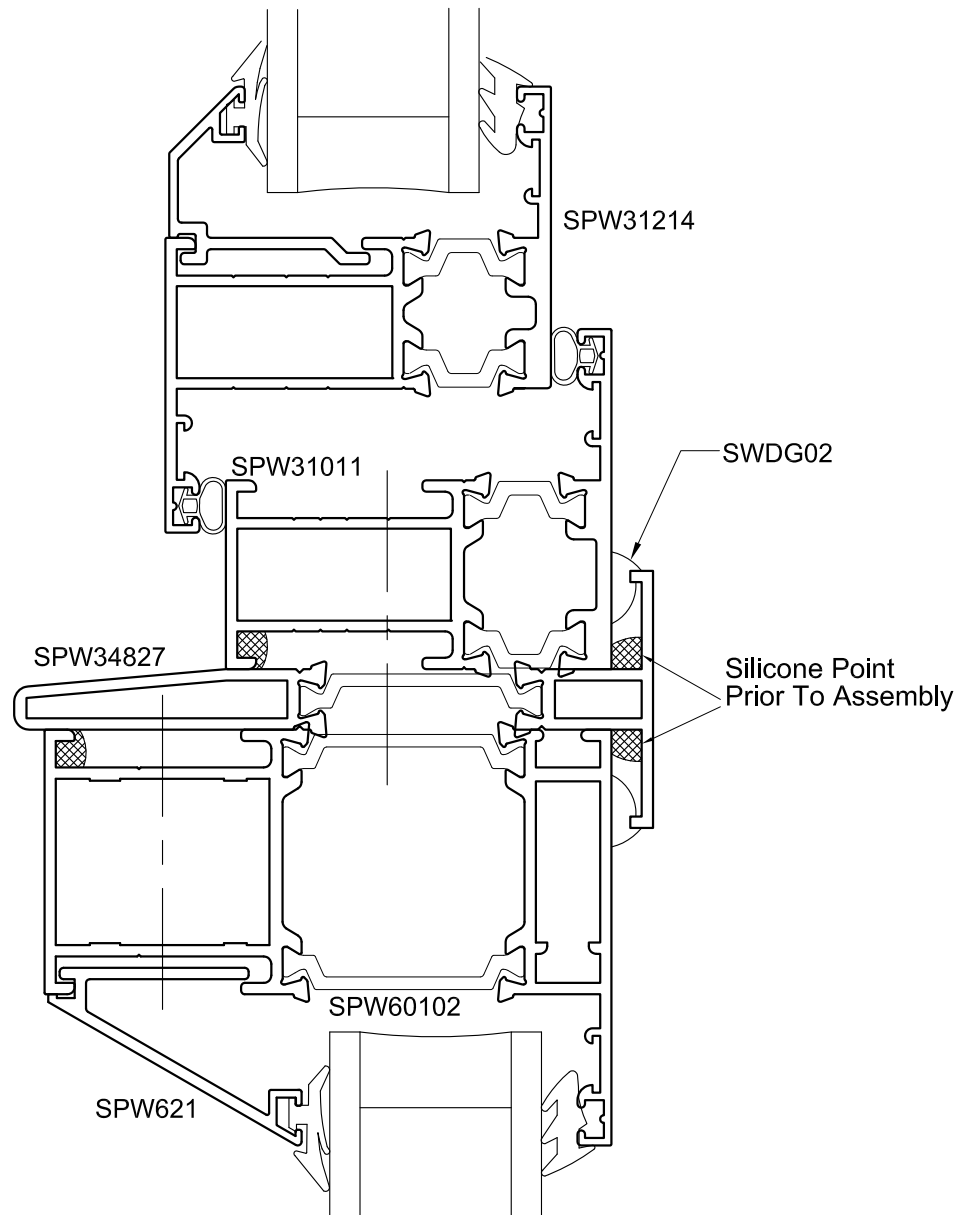

SPW600e Casement

150mm Cill & Drainage Tray

SPW600e.G.108

04.12

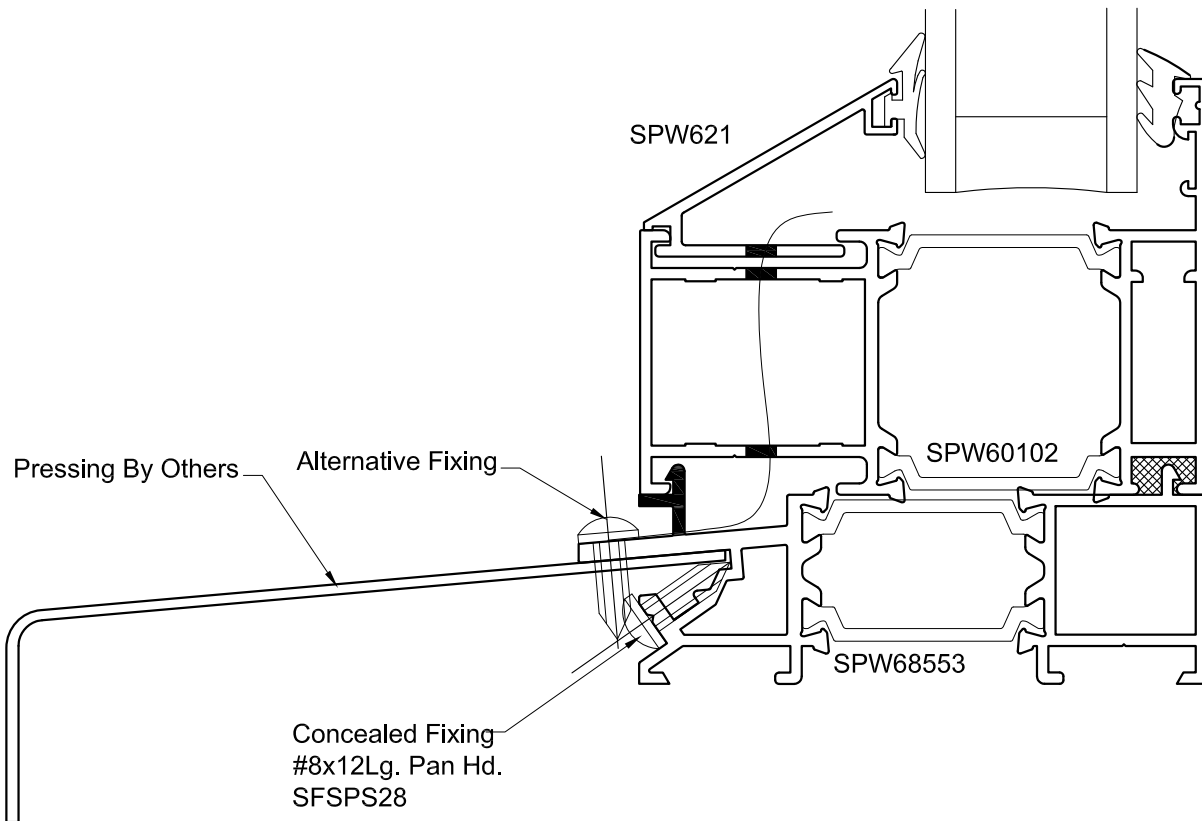
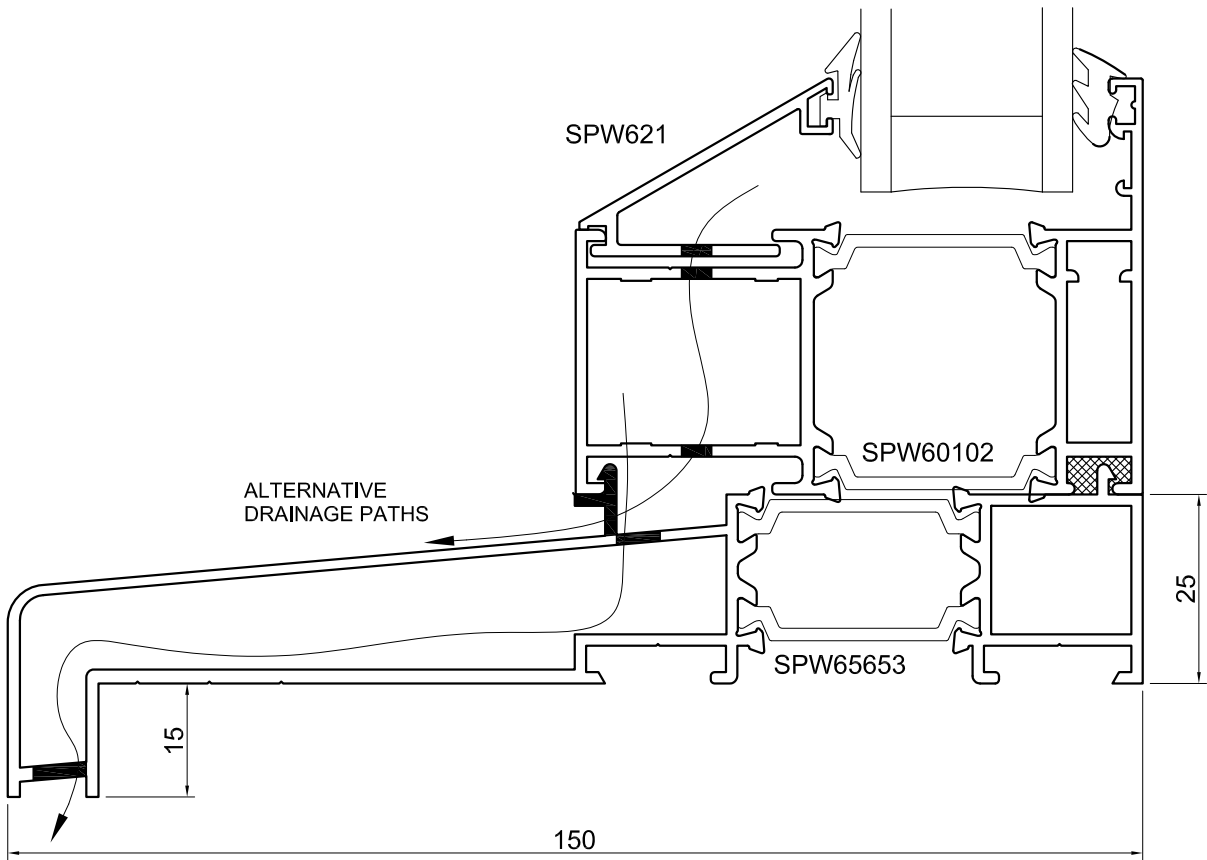

SPW600e.G.109

04.12

SPW600e Casement

190mm Cill

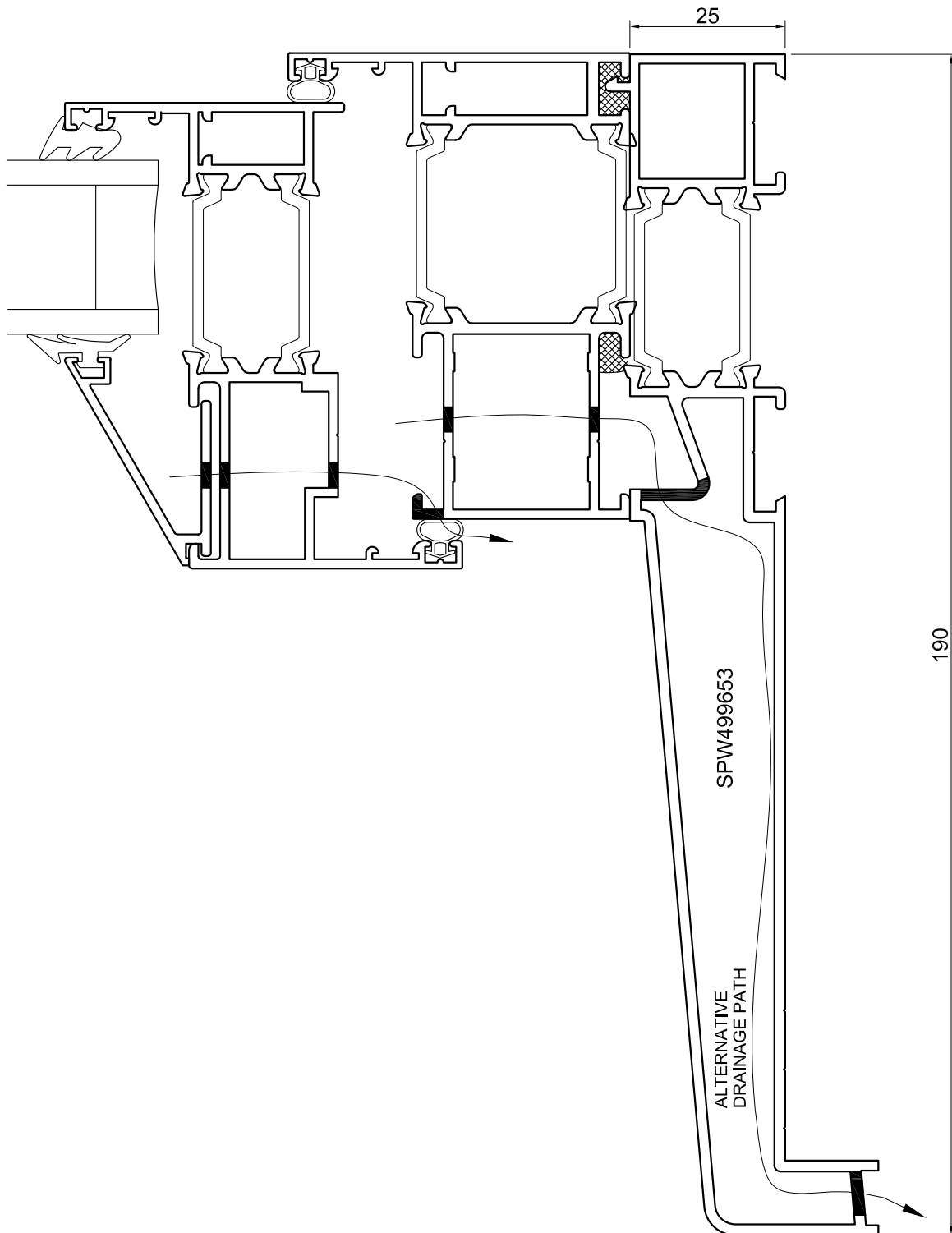

SPW600e Casement

Locking Wedges & Run Up Blocks

SPW600e.G.110

10.13

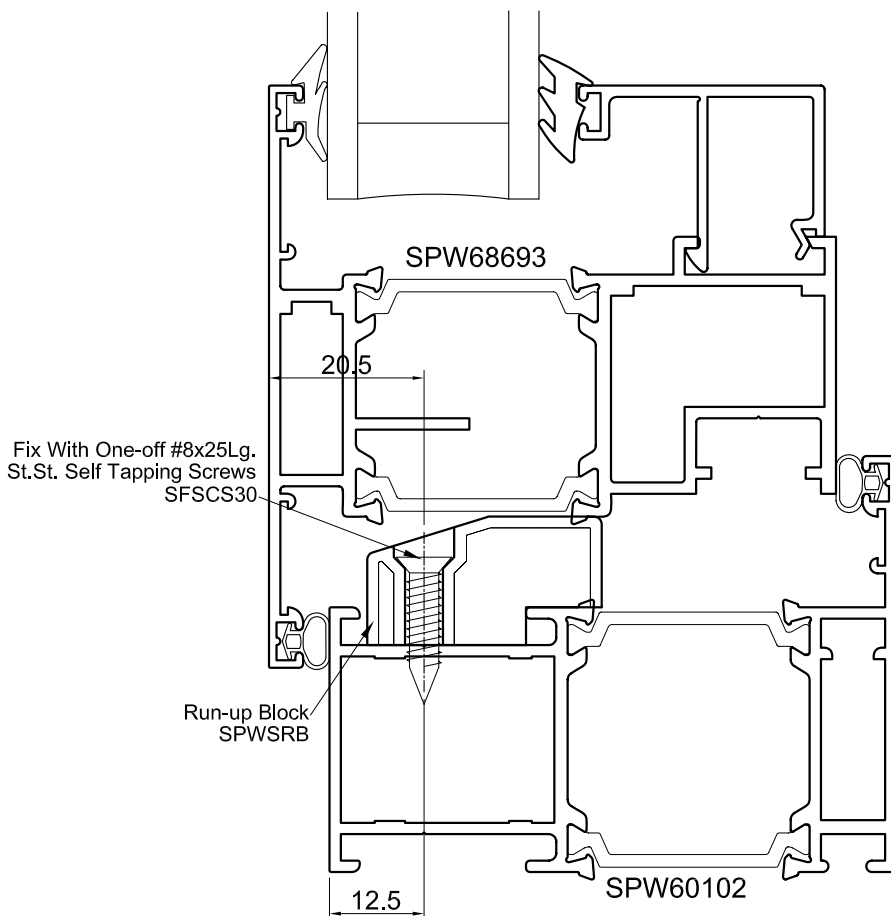
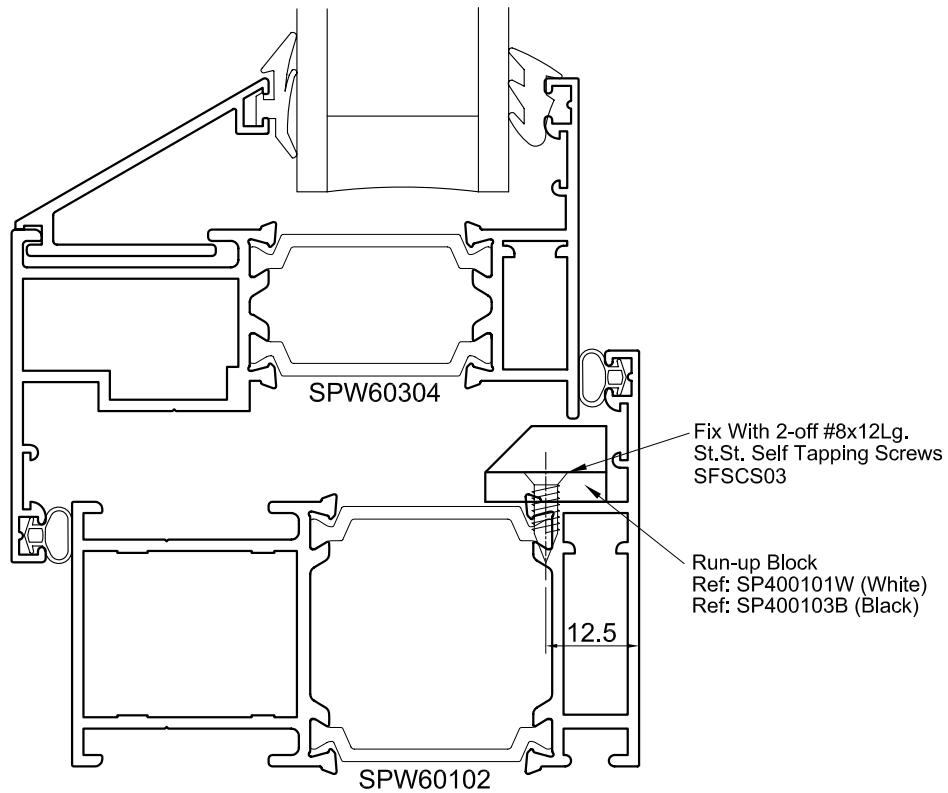

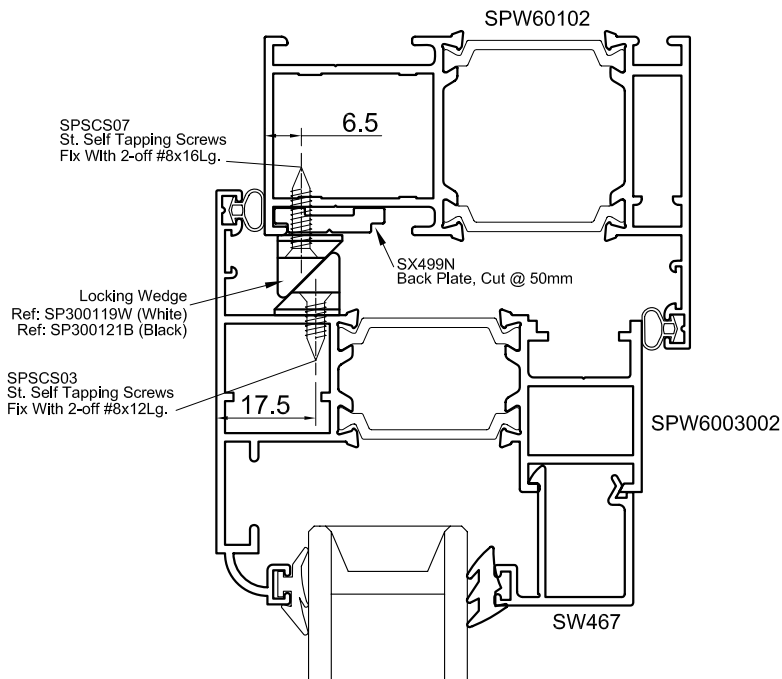
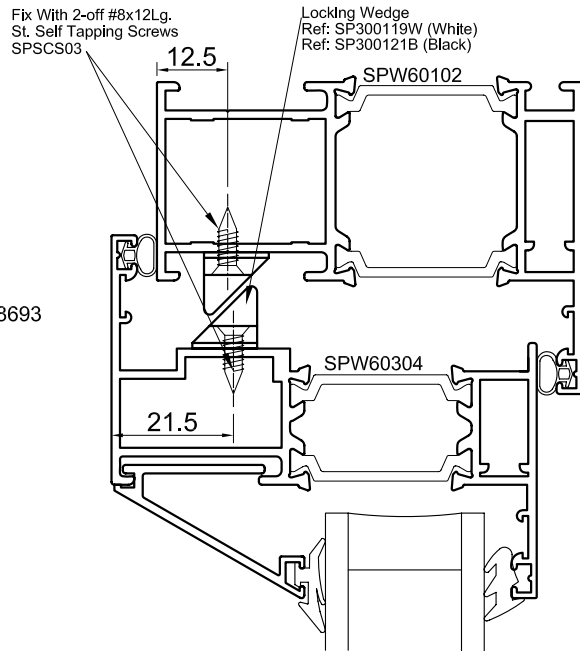
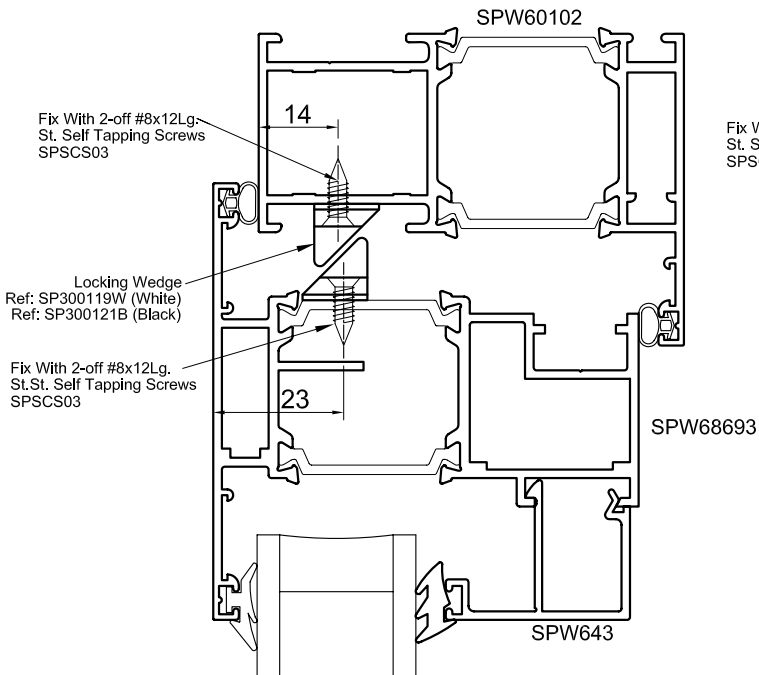

SPW600e Casement

Corner Post - STC7357T

SPW600e.G.112

04.12

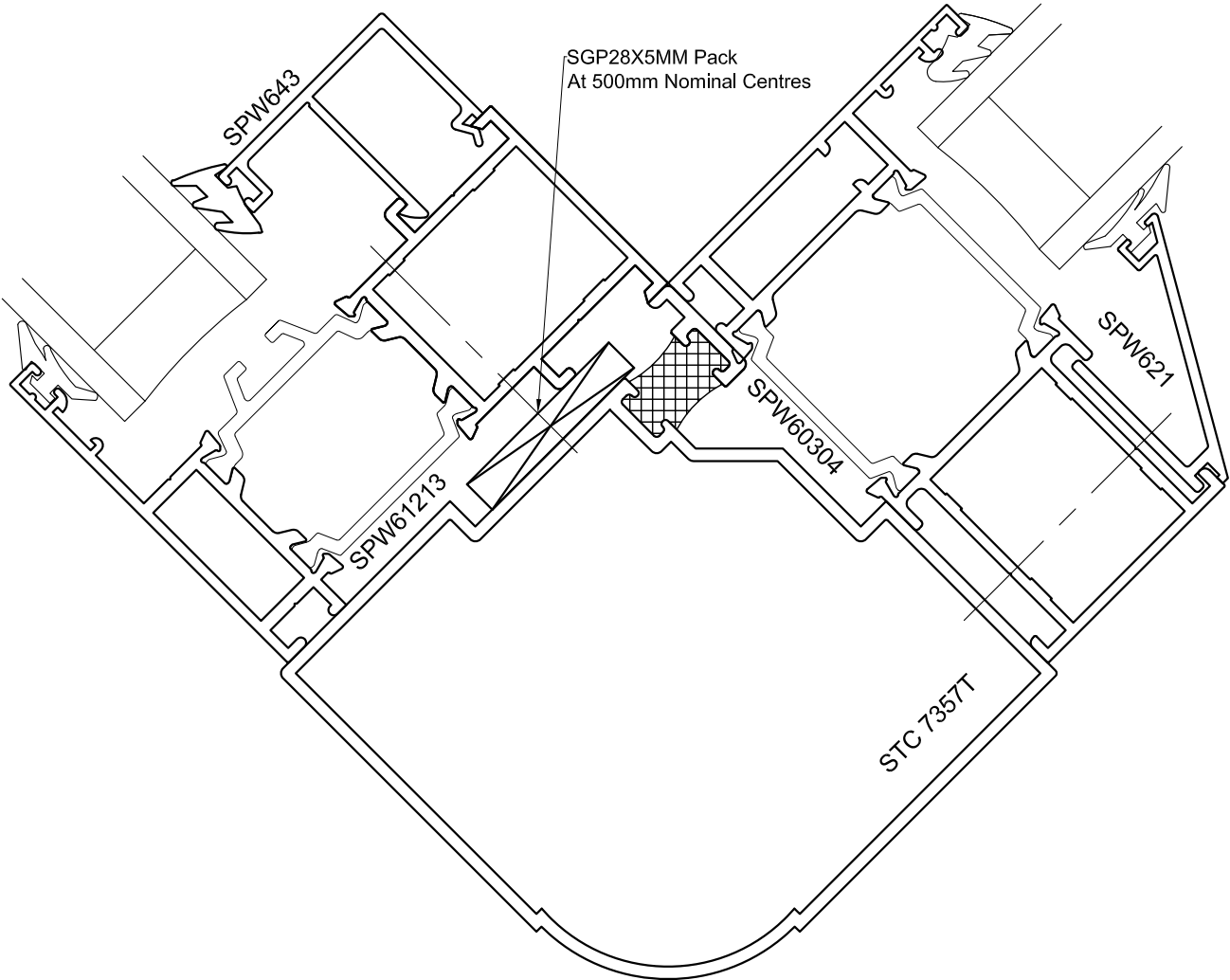

SPW600e Casement

Kingspan Adaptor - 70mm Head/Cill Detail

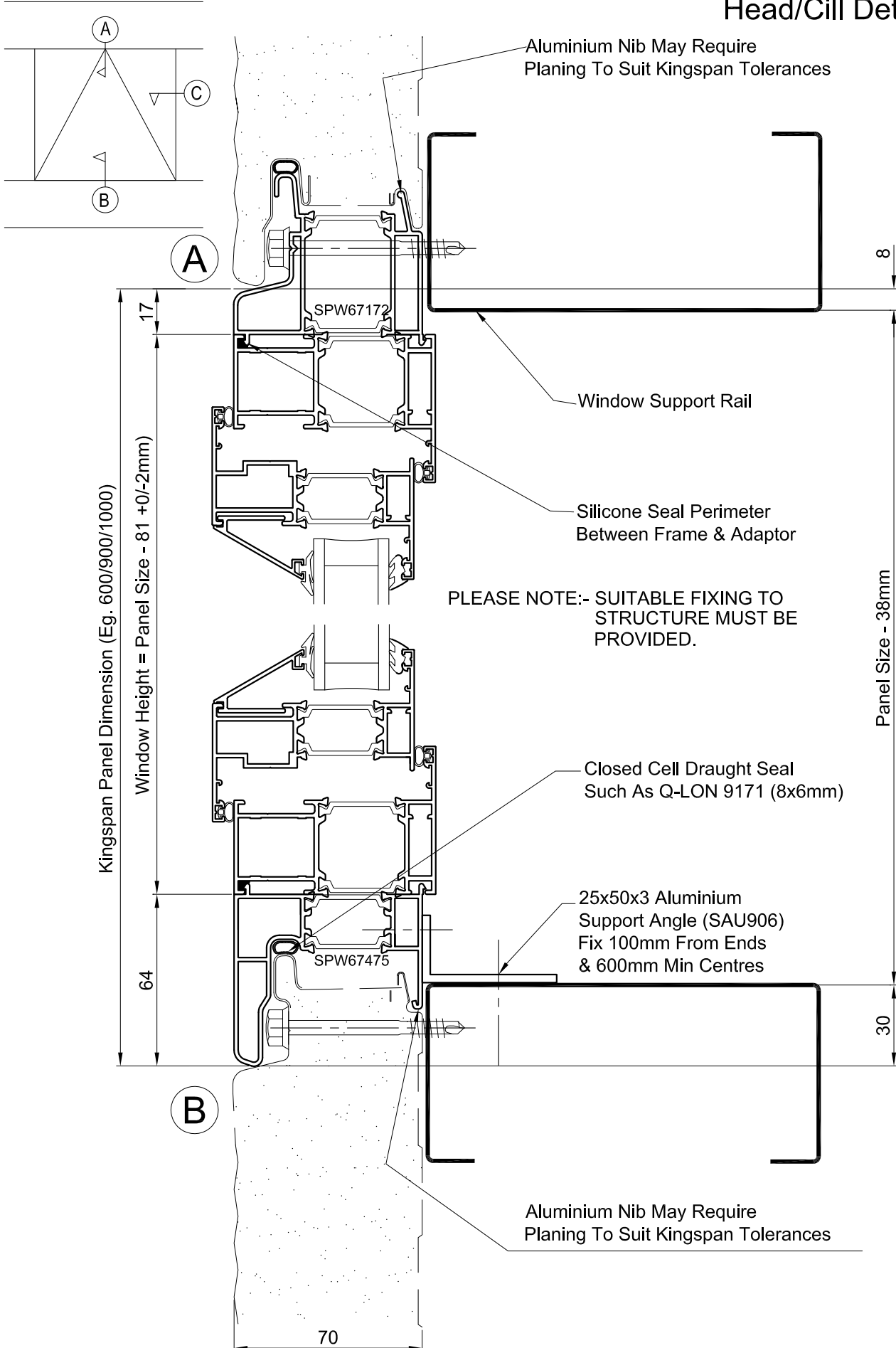

SPW600e Casement

SPW600e.H.102

Kingspan Adaptor - 70mm

04.12

Side Jamb Detail

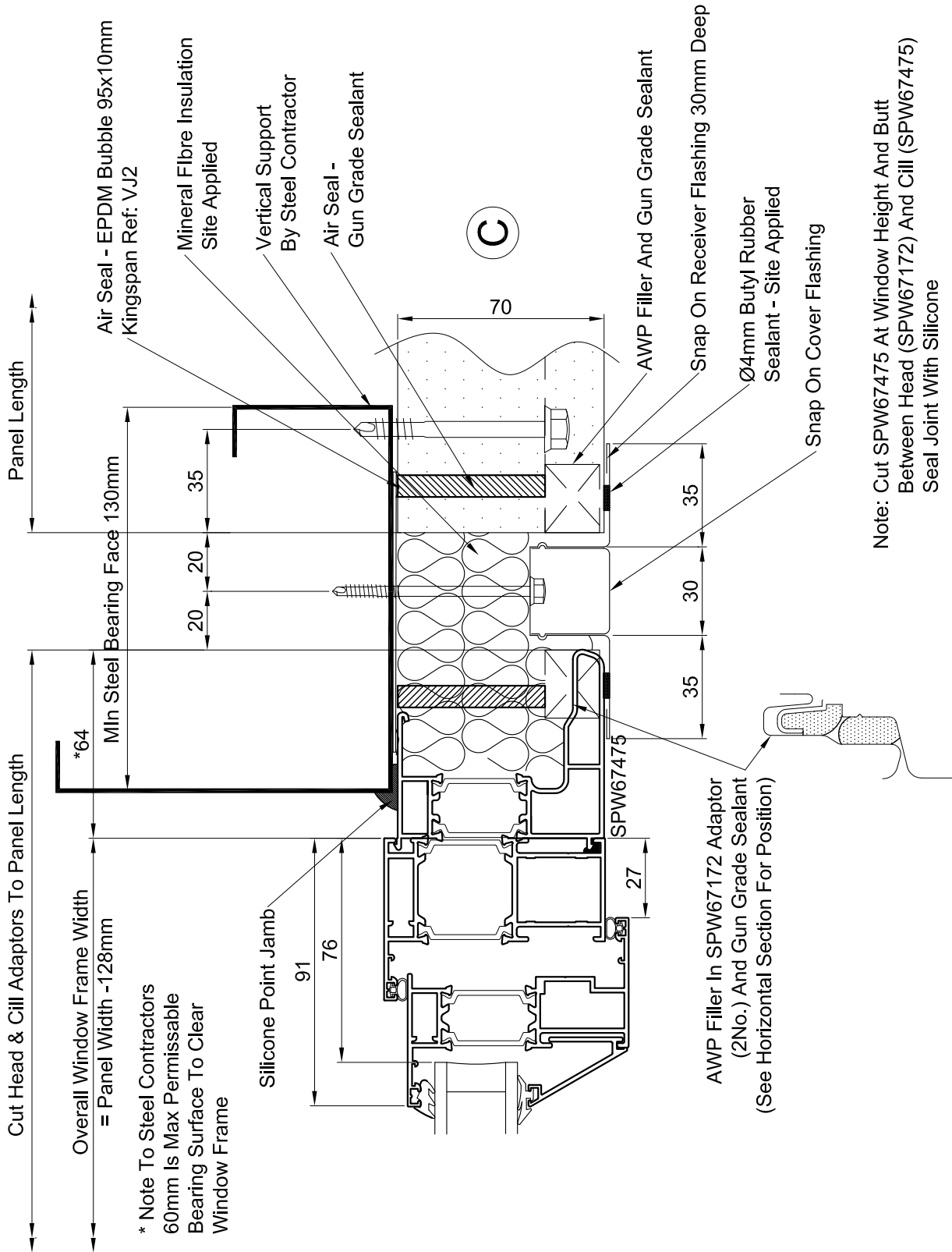

PLEASE NOTE:- SUITABLE FIXING TO STRUCTURE MUST BE PROVIDED.

SPW600e Casement

Kingspan Adaptor - 80mm Head/Cill Detail

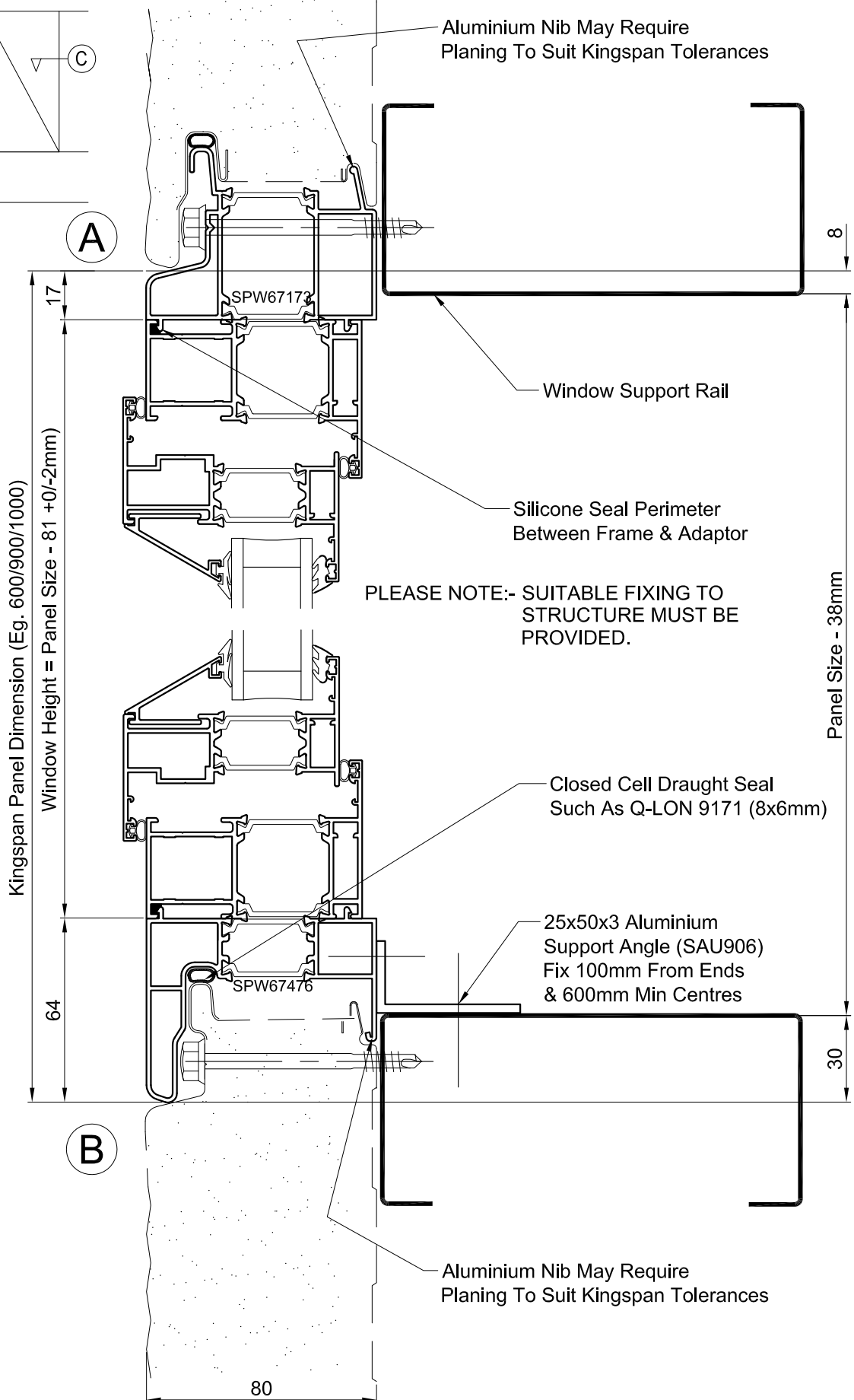
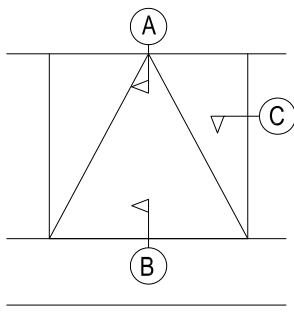

SPW600e Casement

SPW600e.H.104

Kingspan Adaptor - 80mm

04.12

Side Jamb Detail

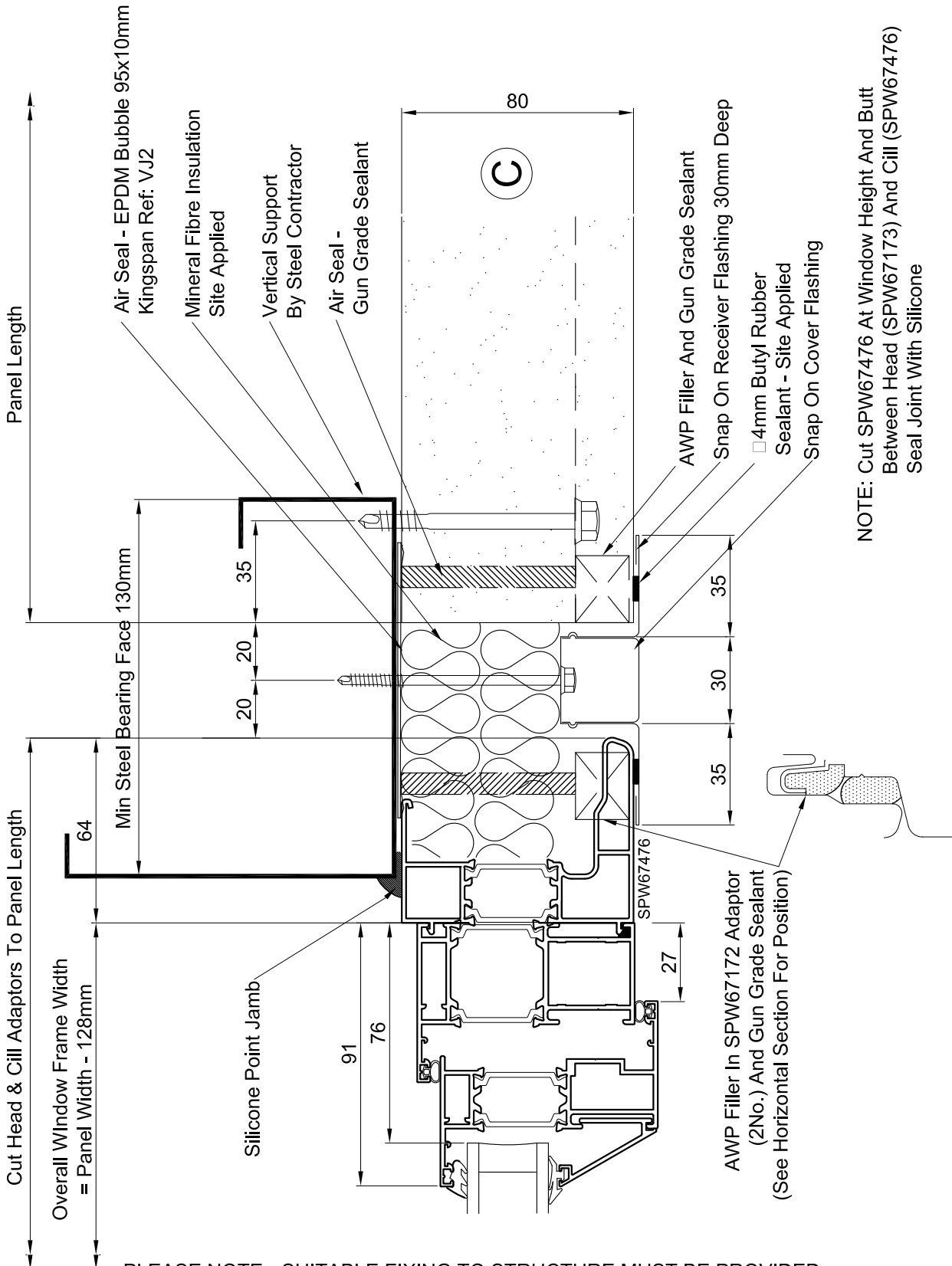

PLEASE NOTE:- SUITABLE FIXING TO STRUCTURE MUST BE PROVIDED.

SPW600e Casement

Kingspan Adaptor - 100mm Head/Cill Detail

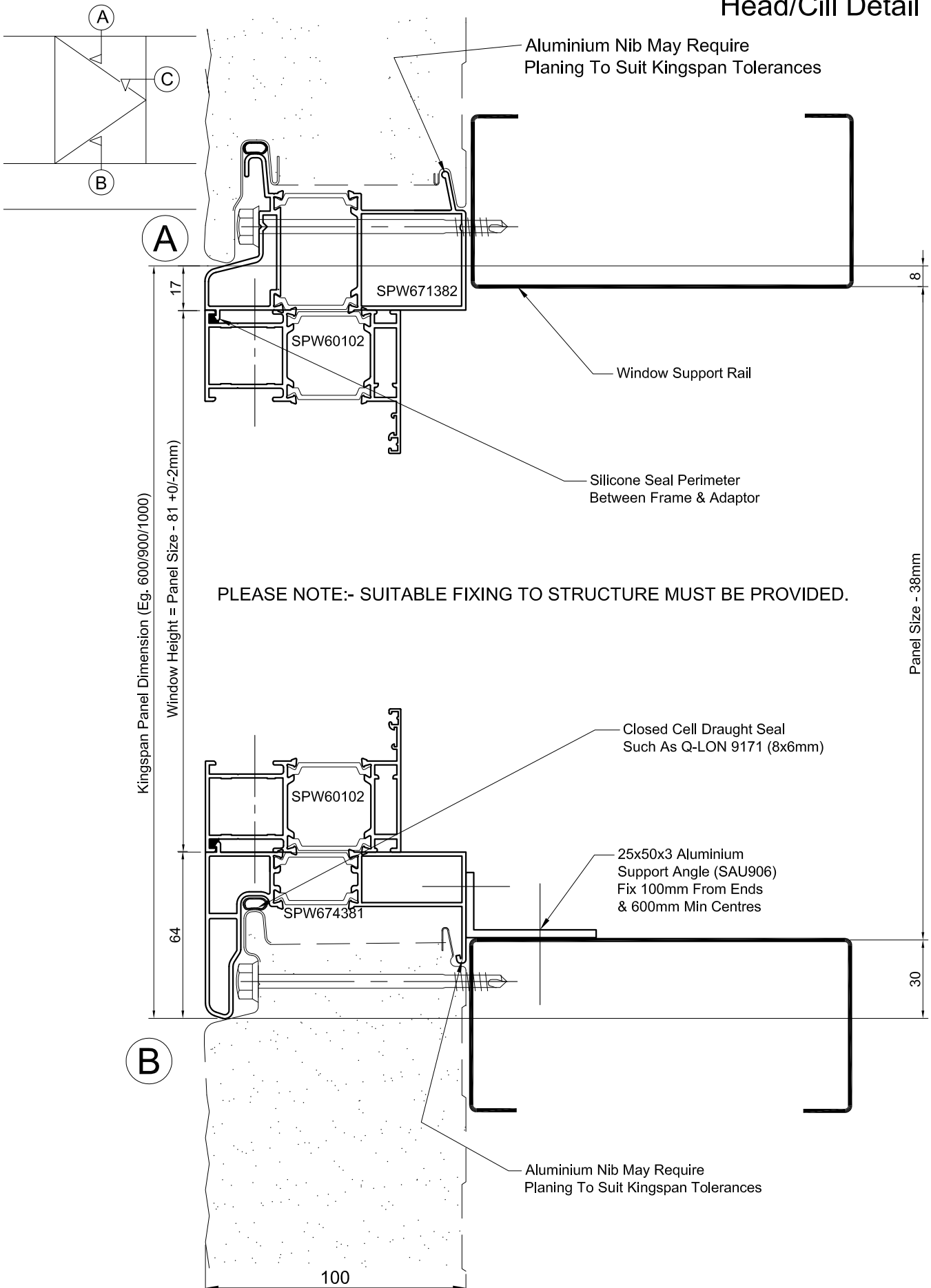

SPW600e Casement

SPW600e.H.106

Kingspan Adaptor - 100mm

04.12

Side Jamb Detail

PLEASE NOTE:- SUITABLE FIXING TO STRUCTURE MUST BE PROVIDED.

