

# 1 Zone 16A OS2 SHEVTEC Controller

## Technical Information & Operating Instructions



### Introduction

The SE Controls SHEVTEC range of control systems includes a built, tested and EN12101-10 certified control panel designed for smoke and/or natural ventilation systems and for use with SE Controls supplied equipment. They must not be used for any other application or in conjunction with other manufacturers' products without prior consultation with SE Controls.

Installation of this equipment must only be carried out by competent and qualified persons.

The Installer and end user are requested to read, understand retain this information pack with the panel for future reference.

This information pack must be retained for future reference by the client and be made available for reference by persons installing, servicing or modifying the panel.

### Application

The 1 Zone 16A OS2 SHEVTEC Controller is an intelligent 24 Volt dc control system designed to drive 2-wire 24V dc actuators in a smoke control and/or natural ventilation system.

Operating from a 230V ac 13A supply, the 1 Zone 16A OS2 SHEVTEC Controller can deliver up to 16 Amp to drive 24 Volt motorised actuators and magnetic catches. Battery backup is provided for continued operation after mains supply interruption (batteries not included)

The 1 Zone 16A OS2 SHEVTEC Controller can be mounted locally to the devices to be operated or in a centralised plant room location.

Each SHEVTEC Controller can operate independently or can be linked to others to produce a networked control system. The networked control system in turn can operate standalone or be linked to a building management system.

# Contents

## 1. General Information

1.1.	General Safety Information	4
1.2.	Health and Safety	4
1.3.	Environment	4
1.4.	User Responsibilities	4
1.5.	Maintenance	5
1.6.	Installation and Connection	5
1.7.	Fault Finding	5
1.8.	Contact Information	5
1.9.	Certification	5

## 2. Specification

2.1.	Device Overview	6
2.2.	Control Board Buttons	6
2.3.	Internal Control Board Indicators	7
2.4.	External Indication	7
2.5.	Volt Free Relay Indication	8
2.6.	Fuse Chart	8
2.7.	Recommended Cable Types	9
2.8.	Hierarchy of Functions	9

## 3. Connections

3.1.	Connections	10
3.2.	Actuators connections	11
3.3.	Manual Control Points	11-12
3.4.	Fire Alarm Signals (FOA, FRA, ARA, SMK)	13
3.5.	Smoke Detectors (SMK)	14
3.6.	Day to Day Switch (DYO, DYC)	15
3.7.	Thermostat (TST)	16
3.8.	BMS Input (AI1, AI2)	17
3.9.	Rain Sensor (RNS)	18
3.14.	Network Connection (NTA, NTB, SCR)	19

## 4. System Design

4.1.	System Design	20
4.2.	Design checklist for each OS2	20
4.3.	Design checklist for each MCP	21
4.4.	Design checklist for each actuator/vent	21

## 5. Installation, Commissioning and Fault-Finding

5.1.	Pre-Installation	22
5.2.	Low voltage connections	23
5.3.	Mains Connection	23
5.4.	Battery installation	23
5.5.	First power-up tests	24
5.6.	Basic Fault-Finding	25
5.7.	Battery Replacement	26
5.8.	OS2 Exterior Layout Design	27
5.9.	OS2 Panel Interior Layout	28

## Important Notices

- The equipment has no mains on/off switch and is intended for permanent connection only.
- Do NOT allow abuse or mishandling of the device.
- Do NOT adjust or alter the device or its enclosure including labelling/markings.
- Do NOT use this controller for any other purpose other than that intended by the manufacturer.
- Do NOT allow installation of this equipment by persons not electrically qualified.
- Damage to the equipment due to failure to test the electrical integrity of external wiring will invalidate any warranties.
- Failure to install the device in accordance with the manufacturer's instructions will invalidate any warranties.
- Failure to follow current electrical regulations governing the installation of fixed equipment can lead to prosecution and may invalidate any warranties.
- Unless otherwise indicated, you must not adjust or remove existing manufacturers cabling or use terminal outputs or inputs for purposes other than their design without written authorization from SE Controls.
- Consumable items e.g. fuses & batteries where replacement is needed must be replaced with parts of equivalent manufacturing standard/compliance and rating.

**SE Controls accepts no liability for failure to comply with these statements or the installation and operation guidance in the following sections of this guide and reserves the right to invalidate the warranty of the controller**

**SE Controls reserves the right to introduce any modifications and improvements to the contents of this publication without the obligation of giving prior notice.**

# 1. General Information

## 1.1. General Safety Information



Read and observe the information contained in these instructions.

Please keep these safety instructions for future reference and maintenance. Reliable operation and the prevention of damage and risks are only granted if the equipment is assembled carefully and the settings are carried out according to these instructions and to the operating instructions of the drives.

Please observe the exact terminal assignment, the minimum and maximum power ratings (see technical data) and the installation instructions.

## 1.2. Health and Safety



**Electrical Safety:** Warning 230V ac mains supply can cause death, serious injury or considerable material damage. Disconnect the equipment from the power supply at all poles before opening, assembling or carrying out any work.

**Electrical safety of batteries:** Short circuiting of the lead acid batteries can cause high currents to flow which can cause rapid heating and a fire risk. Take care to avoid this when transporting and handling batteries. Keep batteries disconnected during installation and modification of the installation.

**Competence:** This equipment is designed for professional installation only by qualified, trained and safety conscious electricians or skilled and trained staff with considerable knowledge of electrical equipment installation. These instructions must be followed and retained for future reference.

**Application:** This equipment is designed exclusively for the purposes of controlling automatically opening smoke and environmental ventilation equipment.



**Personal Protective Equipment:** It is recommended that suitable PPE is worn at all times during the installation and connection of actuator products in accordance with a recommended safe system of work.



**Handling and storage:** This equipment is heavy. Care must be taken in transportation to the installation location and during fitting. The equipment must not be dropped, impacted, allowed to get wet or abused in any other way. Mishandling can result in serious damage to the housing and the components therein.



**Risk of crushing:** this equipment can automatically close windows and other appliances without warning. Beware risk of serious injury from crushing of hands or fingers.

## 1.3. Environment



This equipment is fitted with a pair of lead acid batteries which contain a corrosive gel. These batteries must be regularly inspected for damage and condition. Lead acid batteries are classified as hazardous waste and must be disposed of by an authorised and licensed recycler. They must not be disposed of in household waste or 'general waste' skips.



Redundant electronic products are classified as hazardous waste under the WEEE regulations (Waste Electrical and Electronic Equipment). Electronic parts must be disposed of by an authorised and licensed recycler. They must not be disposed of in household waste or 'general waste' skips.

If recycling facilities are not locally available, contact SE Controls who can arrange for recycling and disposal of old electronic products.

## 1.4. User Responsibilities

**United Kingdom Only:** Frequent inspection of the system should be undertaken by a named suitably trained member of the premises management team.

**For countries outside the United Kingdom:** An environmental control system should only be maintain by a competent person with specialist knowledge of environmental systems and sufficient information with regards the system.

## 1.5. Maintenance



An smoke control system should be checked and serviced periodically in accordance to local smoke control legislation.

Smoke control systems have to be serviced and checked for defects at least once per year by an authorised, trained and competent person.

**Within the UK a suitable service contract with SE Controls is recommended for this purpose, (see section 1.8 for contact information).**

All batteries need to be checked to see if they are within specification and in good condition at least once a year and replaced at least every THREE YEARS (please observe the battery commissioning label).



Ensure that supply voltage and batteries are disconnected before any maintenance work or mechanical/ electrical alterations are made.

**The system must be protected against unintentional start-up!**

After maintenance, modification or repair the system must be functionally retested.

Compatibility; this equipment should only be used to operate with motors and other products approved by SE Controls. No liability will be accepted and neither guarantee nor service is provided if unapproved products are used in conjunction with this equipment.

## 1.6. Installation and Connection



Installation should be carried out by an authorised, trained and competent electrician.

Ensure correct cable type is used throughout the installation. All low voltage cables are to be routed separately from mains voltage cables and other electrically noisy cables. Flexible cables must not be plastered over and freely suspended cables must be provided with strain relief. Cables must be installed in such a way that they cannot be sheared, twisted, pierced or otherwise damaged during installation or use. Junction boxes should be accessible for inspection and maintenance.

**Do not attempt to install or alter the installation of the panel whilst connected to the power supply.**

## 1.7. Fault Finding



In the unlikely event that a problem occurs with the control panel, users are urged to contact SE Controls for assistance.

If the system operates from mains power but when mains power is removed will not operate from batteries, it is possible that the batteries will require replacement.

There are no user repairable parts. Fault rectification must only be carried out by authorised and competent persons.

## 1.8. Contact Information

**For sales, technical support and maintenance please contact:**

SE Controls  
Lancaster House  
Wellington Crescent  
Fradley Park  
Lichfield  
Staffordshire  
WS13 8RZ

**Tel:** 01543 443060

**Fax:** 01543 443070

**Website:** [www.secontrols.com](http://www.secontrols.com)

## 1.9. Certification

SE Controls hereby certify that the parts and services detailed hereon have been manufactured, inspected, tested and supplied in accordance with the conditions and requirements of the procedures as documented in the Company Quality Assurance System to ensure conformance with SE Controls' specifications, and with the contract or order conditions of our BS EN ISO9001:2008 registration.



Our equipment is built and tested in accordance with the requirements of EN12101-10:2005/AC:2007. Certification may be provided on request.

## 2. Specification

### 2.1. Device Overview

<b>Part Number</b>	FCS12250101
<b>Dimensions</b>	600 x 400 x 250mm (H x W x D)
<b>Mass Approx.</b>	Without batteries - 8.55kg / With batteries - 20kg
<b>Supply</b>	230V ac 50/60Hz. from a 13A fused spur
<b>Output</b>	Output nominal 24V dc multi-channel output not to exceed 8A per channel for 60 seconds. Peak current combined output can exceed 16A for a short duration
<b>Battery Backup</b>	4 x 12V dc 7.0Ah sealed lead-acid (batteries not included)
<b>Expected Battery Life</b>	3 Years @ 25°C
<b>Real Time Clock Battery Life</b>	10 Years
<b>Cable Entries</b>	Cable entries are via up to 32 off 20mm end mounted cable glands and/or one rear entry slot for concealed connection
<b>IP Rating</b>	IP30
<b>Humidity Range</b>	10 to 90% Non-condensing
<b>Storage</b>	-20°C to +50°C
<b>Operating Temperature</b>	-20 °C to +40 °C
<b>*Battery Standby Time</b>	72 Hours with maximum 40mA standby drain on PER permanent*
<b>Operating Temp</b>	-5°C to 40°C

\* Standby drain current comprises enabled fire inputs, communication cards, and other loads connected to PER.

### 2.2. Control Board Buttons

<b>Button</b>	<b>Detail</b>
<b>SERV</b>	Not used unless OSILon communication board is installed - Light LD2 when pressed
<b>BPD</b>	When pressed, powers down the unit if running on batteries
<b>BPUP</b>	When pressed, powers up the unit if fully charged batteries connected and no mains supply is available (useful for commissioning tests).

### 2.3. Internal Control Board Indicators

LED	Colour	Detail
LD1 POW	Green	Lit when mains supply is connected .
LD2 WINK	Red	Reserved communication cards use - Illuminated when SERV Pressed
LD3 HEALTHY	Green	Healthy Lamp - Lit when controller has no faults.
LD4 ACTIVATED	Red	Lit when the controller is activated by a fire input or via the Fireman's switch Open signal. Does not respond to NV demands.
LD5 MAINTENANCE	Yellow	Lit when maintenance input is active.
LD6 WDG	Yellow	Watchdog - Flashes at 1Hz to indicate embedded firmware is loaded and running.
LD7 PSU	Green	On when battery and power supply ok. Flashes Alternately with LD6 if mains supply failure detected. Flashes in tandem with LD6 if battery failure detected. Flicks off for half a second every 10 seconds to indicate bulk battery charging stage.
LD8 BAT	Red	Lit when controller is powered from the battery supply.
LD9	Green	Lit when actuator (1) is closing.
LD10	Red	Lit when actuator (1) is opening.
LD11	Green	Lit when actuator (2) is closing.
LD12	Red	Lit when actuator (2) is opening.

### 2.4. External Communication

Lamp	Connection	Detail
Maintenance Fault	MLP;PER	Lit when Maintenance mode is active.
Fire Condition	ALP;PER	Lit when the controller is activated by a fire input or via the Fireman's switch Open signal.
Standby	HLP;PER	Lit when healthy and mains supply is connected.

**Note:** The function of the LEDs reflects the maintenance, activity and healthy relays. The function of these relays can be modified by OS parameter changes.

## 2.5. Volt Free Realy Indication

Terminal	Description
<b>ACM</b>	Activated relay common
<b>ANC</b>	Activated relay normally closed (opens when activated)
<b>ANO</b>	Activated relay normally open (closes when activated)
<b>HCM</b>	Healthy relay common
<b>HNC</b>	Healthy relay normally closed (opens when healthy)
<b>HNO</b>	Healthy relay normally open(closes when healthy)
<b>MCM</b>	Maintenance relay common
<b>MNC</b>	Maintenance relay normally closed (opens when maintenance input activated)
<b>MNO</b>	Maintenance relay normally open (closes when maintenance input activated)

## 2.6. Fuse Chart

Fuse		Function	If Open Circuit
<b>1</b>	<b>16 Amp</b>	24V ac Input	LD1 and 3 go out; If batteries are healthy, LD7 & 8 flash alternately; LEDs on MCP flash alternately; Standby (green) LED goes out; Healthy relay changes state. If sustained, the batteries will flatten, and all LEDs go out.
<b>2</b>	<b>1 Amp</b>	PER- Battery backed supply	Standby LED goes out; PER supply terminals off; If external alarm connected will set off.
<b>3</b>	<b>500mA</b>	AUX- Auxiliary supply	AUX supply terminals off.
<b>4</b>	<b>16 Amp</b>	Battery	LD7 & 8 flash in tandem; LD3 turns off; Standby LED goes out; Healthy relay changes state..
<b>5</b>	<b>10 Amp</b>	Actuator 1	When open circuit Actuator Zone 1 will not function.
<b>6</b>	<b>10 Amp</b>	Actuator 2	When open circuit Actuator Zone 2 will not function.
<b>EMC Filter</b>	<b>3 Amp</b>	Mains voltage input	LD1 and 3 go out; If batteries are healthy, LD7 & 8 flash alternately; LEDs on MCP flash alternately; Standby (green) LED goes out; Healthy relay changes state. If sustained, the batteries will flatten, and all LEDs go out.

**Note:** If a fuse clears, check wiring / external devices for damage and incorrect termination / earth faults before replacement.

## 2.7. Recommended Cable Types

Cabling For	Minimum Number of Cores	Recommended Cable Type
<b>Mains Supply Cable</b>	2 Core + Earth x 2.5mm <sup>2</sup>	FP Plus
<b>OS2 MCP</b>	5 Core (2 Core + 3 Core) + Earth x 1.5mm <sup>2</sup>	FP Plus
<b>24V dc Actuator</b>	2 Core + Earth x 2.5mm <sup>2</sup>	FP Plus
<b>OS2 Smoke Detector</b>	3 Core + Earth x 1.5mm <sup>2</sup>	FP Plus
<b>OSlink Network Cable</b>	4 Core + Earth x 1.5mm <sup>2</sup>	FP Plus
<b>SHEVTEC Repeater Panel</b>	4 Core + Earth x 1.5mm <sup>2</sup>	FP Plus
<b>Day to day Switch</b>	3 Core + Earth x 1.5mm <sup>2</sup>	Any Appropriate Cable Type
<b>Rain Sensor</b>	3 Core + Earth x 1.5mm <sup>2</sup>	Any Appropriate Cable Type
<b>Thermostat</b>	2 Core + Earth x 2.5mm <sup>2</sup>	Any Appropriate Cable Type
<b>PIR Sensor</b>	3 Core + Earth x 1.5mm <sup>2</sup>	Any Appropriate Cable Type

All cabling should be in accordance with relevant standards and regulations for electrical installation such as BS7671.

## 2.8. Hierarchy of Functions

In operation, the control inputs are organised in a strict hierarchical priority order.

1. Maintenance (highest priority)
2. Override alarm
3. Fireman's switch close demand
4. Fireman's switch open demand
5. Fire alarm
6. Auto Reset Fire Alarm
7. Smoke Detector
8. Slave (Follower) demand
9. Mains Failure
10. Rain Sensor
11. Thermostat / 0-10V / Day-to-day switch (lowest priority)

# 3. Connections

## 3.1 Connections

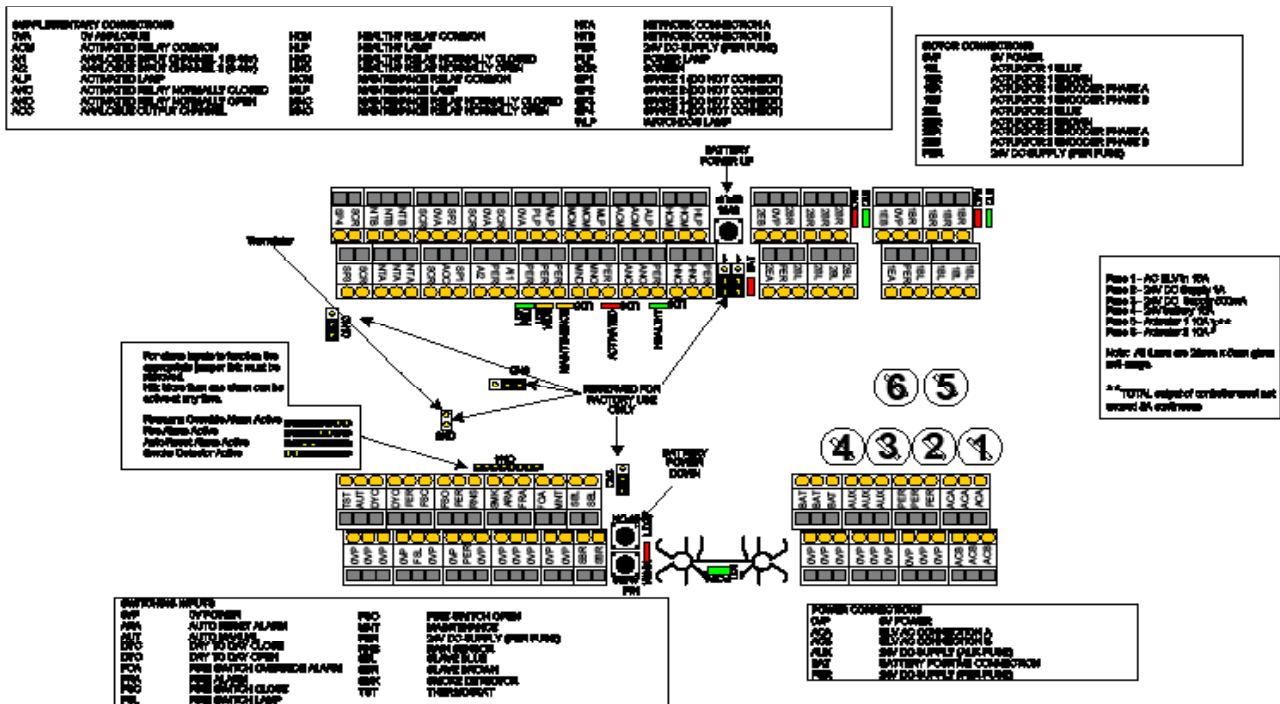

Note that the above terminal drawing appears on a silver label affixed to the inner face of the lid of this panel. This label must **NOT** be removed.

All terminals have a cable capacity of 2.5mm<sup>2</sup> stranded or 4mm<sup>2</sup> solid. Each terminal is identified with a 3-letter code which is expanded on the terminal label.

Do not interfere with fixing or location of the thermistor.

The following sections are to be used for guidance only and are subject to change.

All external switch contacts are to be volt-free and capable of carrying 24V dc at low currents. The maximum cable length for digital control input signals is 500M.

0-10 Volt signals must remain stable and 'spike' free for a period of 2 seconds before the controller will respond to them. In 10% step mode, the controller only responds to 0-10V signals in steps of whole volts ±250mV. In 5% step mode, each step is half a volt.

Natural ventilation accessories (e.g., rain sensors) should be powered from the AUX supply. Essential smoke accessories (e.g., smoke detectors) should be powered from the PER supply.

Strip the outer sheath of all cables back to the entry point of the enclosure. Ensure enough sheath is left to provide mechanical protection against cable movement over time.

Inner cable cores should be dressed under the edges of the power and control board. This provides a neater and more ordered solution. Only strip inner cores sufficiently to make a good electromechanical contact with the terminal blocks.

Where multiple actuator leads are to be connected to the controller, it is advisable to use an external junction box to reduce the number of cable glands required, if using screw-terminal joints ensure they are of the enclosed type.

The default controller settings have been chosen to cater for many applications. If alternate settings are required please contact SE Controls.

### 3.2. Actuator Connections

OS2 SHEVTEC Controller has two separately fused 24V dc actuator output channels. Each output channel has terminals for connecting up to 4 actuators.

The default mode of operation of these outputs is timed off, reversing polarity, and is intended for use with linear and chain actuators. Locking catches, magnetic catches and rotary dampers can be used but require changes to the default settings of the controller by SE Controls

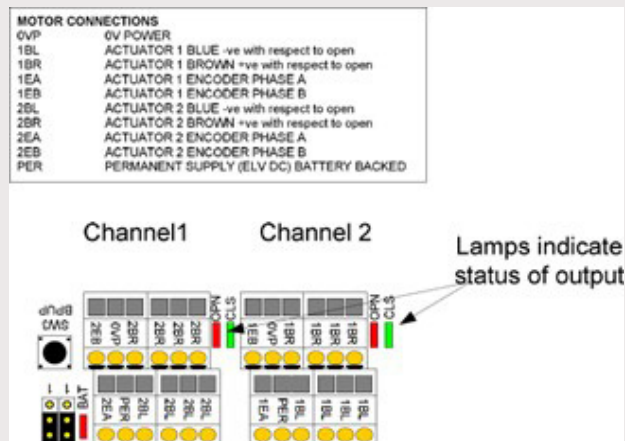

**Output mode - timed off, reversing polarity**

**Actuator Full Stroke Period (natural ventilation) - 18 seconds**

**Alarm Full Stroke Period (Smoke Vent) - 180 seconds**

**Over current response >8A for 2 seconds**

### 3.3. Manual Control Points

These switches are used to manually open and close actuators in a smoke control system. There is a set lock-out period of 5 seconds between successive operations. The actuators open full stroke in response to a transitory operation of the Fireman Switch open demand. However, to prevent finger trapping issues, the actuators only close whilst the Fireman's Switch close demand is maintained.

Maintaining the Fireman's Switch close demand also holds the actuators in the closed state. Releasing the Fireman's Switch close demand allows natural ventilation operation to resume.

Note that SE Controls can change the default Fireman's Switch close mode to close full stroke in response to a brief press of the reset button. This mode change is only recommended where the activated vent is at least 2.4M above ground level to minimise finger trapping issues.

#### Tamper Proof Manual Control Points

<b>OS2 Tamperproof MCP Module &amp; Adaptor Plate</b>	Part Number FCS00200081
<b>OS2 Tamperproof MCP Module Assembly</b>	Part Number FCS00200037
<b>OS2 MCP Adaptor Plate</b>	Part Number FCS00200017

#### Standard Manual Control Points

<b>OS2 Module &amp; Adaptor Plate</b>	Part Number FCS00200080
<b>OS2 MCP Module Assembly</b>	Part Number FCS00200016
<b>OS2 MCP Adaptor Plate</b>	Part Number FCS00200017

#### MCP Keys

<b>MCP Dumb Reset Key</b>	Part Number FCS00200024
<b>Activation Key - Open Only</b>	Part Number FCS00200033

All connections to the OS2 MCP are made via the connection PCB mounted within the adapter plate assembly. (See diagram that follows on page 12.)

### 3.3. Manual Control Points, cont.

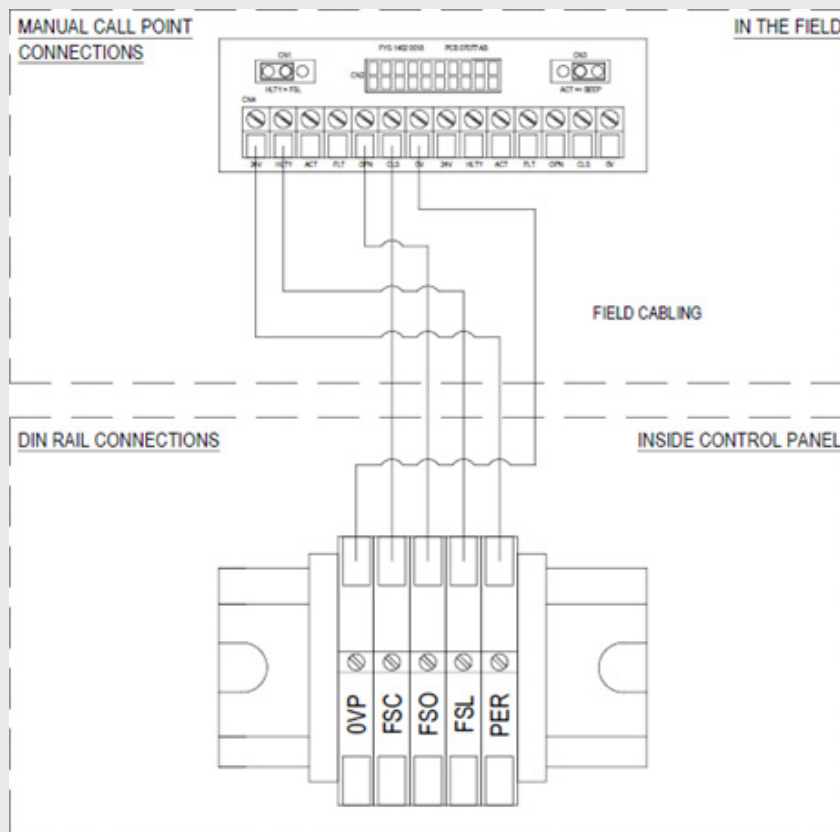

The connection PCB has 14 terminals, consisting of 2 pairs of 7 connections. For OS2 products, it is only necessary to connect to 5 of these signals as follows:

MCP Terminal	OS2 Terminal	Description
24V	PER	24V dc power supply rail from OS2 controller.
HLTY	FSL	Healthy indicator – Fireman’s switch lamp output from OS2 controller.
ACT	-	No connection required/made for OS2 systems.
FLT	-	No connection required/made for OS2 systems.
OPN	FSO	Open demand – Fireman’s switch open demand.
CLS	FSC	Close demand – Fireman’s switch close demand.
0V	0VP	0V power supply rail from OS2 controller.

Note that each pair of connections are interconnected within the PCB assembly. The second set of terminals may be used to daisy-chain multiple MCPs to one OS2.

The jumper CN1 must be fitted in the left hand (“HLTY=FSL”) position.

The jumper CN3 enables and disables the sounder. The default position is disabled (right)

The OS2 must have both battery and mains power removed before installing the MCP to the adapter plate.

The MCP must be secured using the two fixing screws (Torx-T8) on the underside of the MCP module.

**Important; for instructions on installation and operation of the MCP refer to the user guide accompanying the device or contact SE Controls.**

### 3.4. Fire Alarm Signals (FOA, FRA, ARA, SMK)

All fire alarm input signals require a Normally Closed volt-free-contact which opens on first signal initiation. The unit comes with all alarms hardware disabled via jumper links. To enable an alarm input, refer to the figure below.

Each fire alarm input has different functionality. It is not mandatory to connect a particular type of device to a particular fire alarm input, but to the one(s) that provide the required functionality.

Fire Alarm – Opens on activation; Use of Fireman’s Switch close allowed.

Auto reset Fire Alarm – Opens on activation; Use of Fireman’s switch close allowed; 30 second lock-out period after activation before reset; 120 second lock-out following reset before subsequent re- activation.

Fireman’s Override Alarm – Opens on activation- Does not allow Fireman’s Switch Close until alarm reset.

Smoke Detector Input – Open on activation – Does not allow Fireman’s Switch Close until alarm reset.

The alarm activation direction, SE Controls can configure Fireman’s Switch reaction mode and lock-out periods.

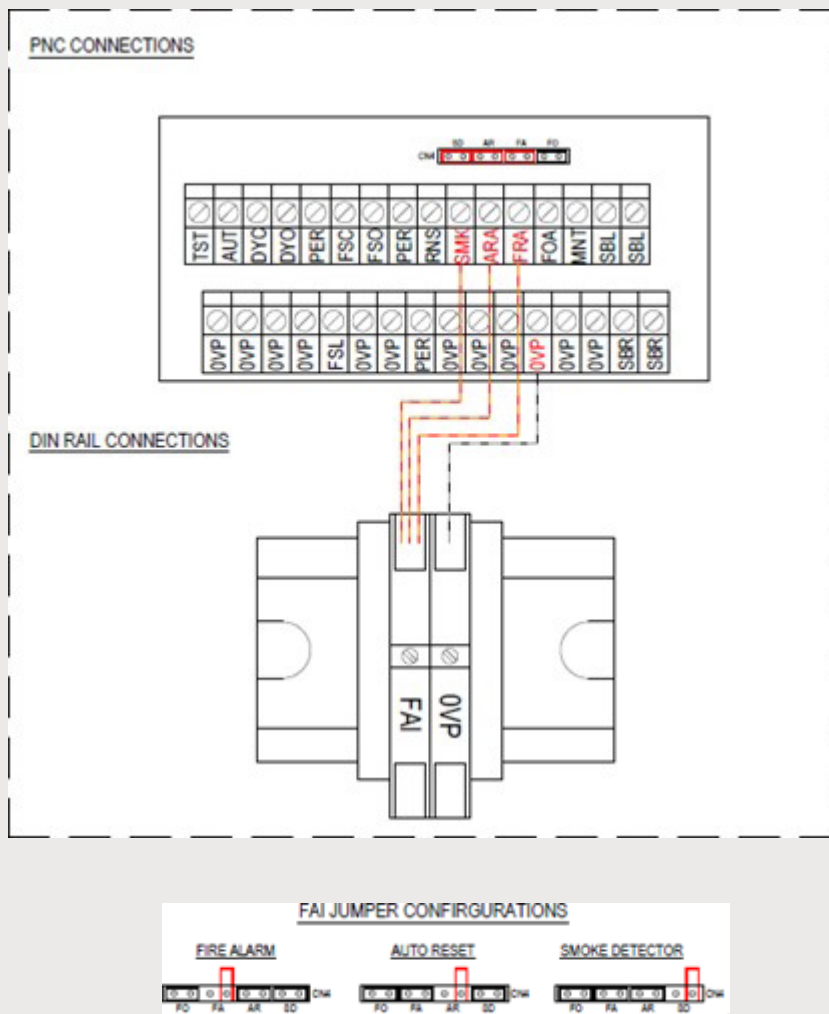

### 3.5. Smoke Detectors (SMK)

Smoke detector heads are required to provide a normally closed volt-free contact. Smoke detectors should be powered from the PER supply rail. The recommended maximum number of Smoke detectors is 5 connected to a single OS2 SHEVTEC controller.

It is important that the quiescent current of the smoke detectors is kept to a minimum as their current draw will greatly impact on standby times. The peak current draw on the PER permanent supply should never exceed 1Amp.

**Smoke Detector Base** Part Number ADA45681245  
**Smoke Detector Head** Part Number ADA55000318

This smoke detector is an exclusive SE Controls product and has been specifically designed to operate as part of SE Controls SHEVTEC systems. It has been marked as such to aid in identification for servicing and replacement.

Other models / types are not suitable products for use in SHEVS and are not compatible.

The detector is a 2-part assembly comprising a head and a base which clip together. To prevent interference by unauthorised persons the base incorporates a locking mechanism which then prevents disassembly without a tool.

The detector head has an LED indicator to provide status information. Distinctive markings on the head set it apart from other standard types of detector, and each unit is supplied with a clip-on dust cover which should be removed at commissioning stage.

#### Important Notes:



Test using canned Smoke or other approved smoke generating method. No other method is acceptable.

Removal of the head **DOES NOT** cause activation of the system. Once installation is complete, **ensure lock is engaged to prevent unauthorised removal of the detector head, (see connection diagram).**

The current model is **NOT** suitable for use with OS2 SHEVTEC Controller Auto Reset Fire Alarms. Please seek further advice from SE Controls if this facility is required.

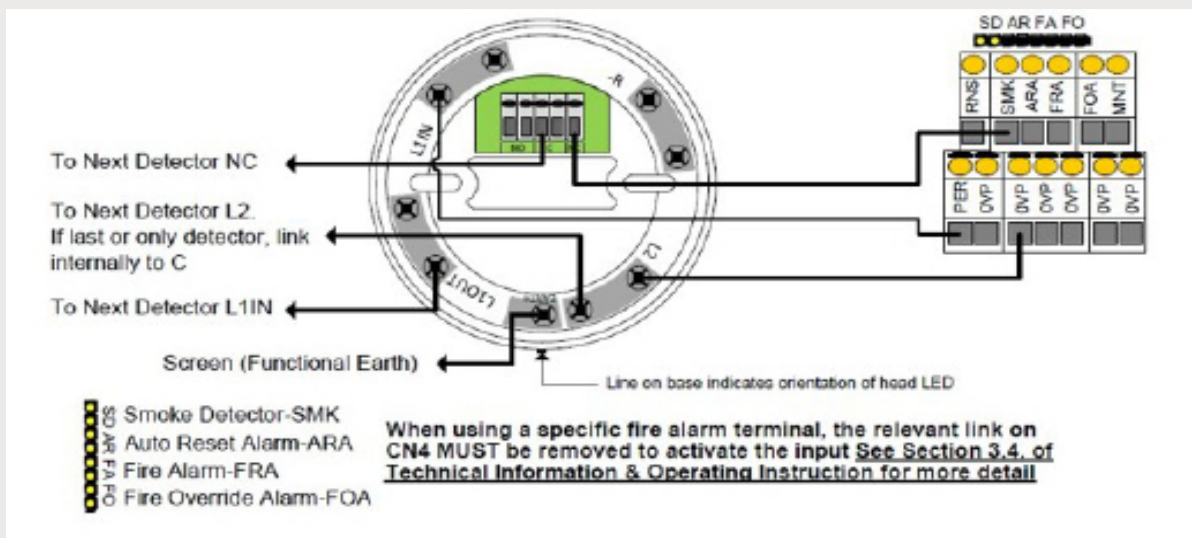

### 3.6. Day to Day Switch (DYO, DYC)

Connecting terminals DYO and DYC to 0VP will open and close the vent in natural ventilation mode. The default mode requires a spring centre 3 position switch having 2 normally open contacts. The actuator will only move whilst the input demand is in force and the total movement time in the requested direction is less than 18 seconds (default). Releasing the switch will stop the movement.

The day-to-day inputs only operate whilst the controller is in manual operational mode.

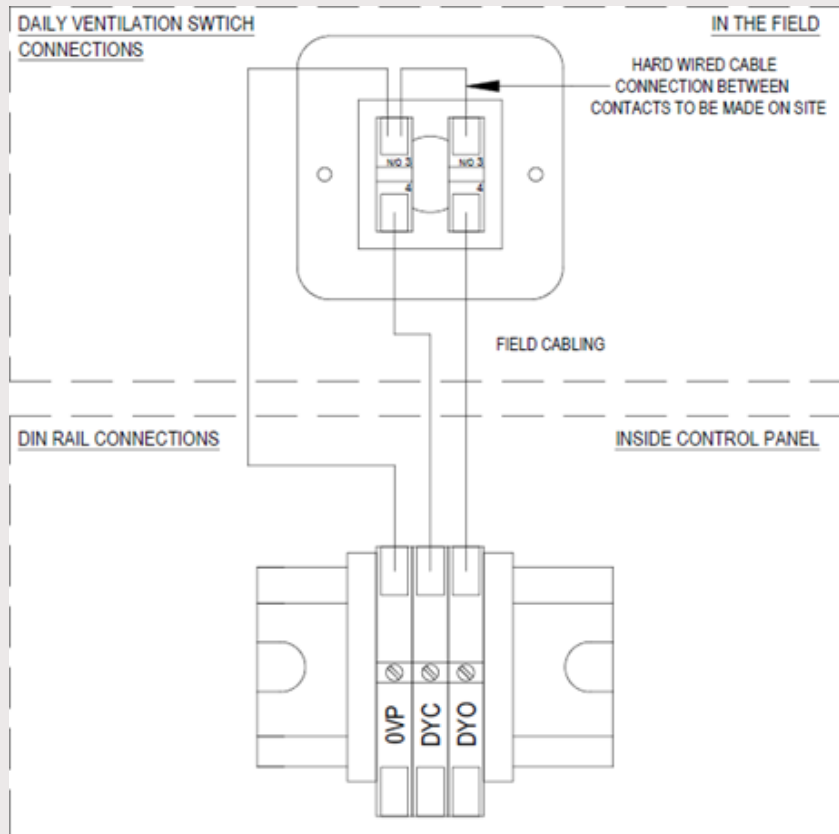

### 3.7. Thermostat (TST)

A simple volt free room thermostat can be used to operate the OS2 SHEVTEC Controller. The output contact is required to close when a demand to open a vent is required.

When the demand is received, power is applied to the actuator outputs for 18 seconds in the open direction.

Both movements are subject to a 180 second lockout period which prevents frequent unwanted operation.

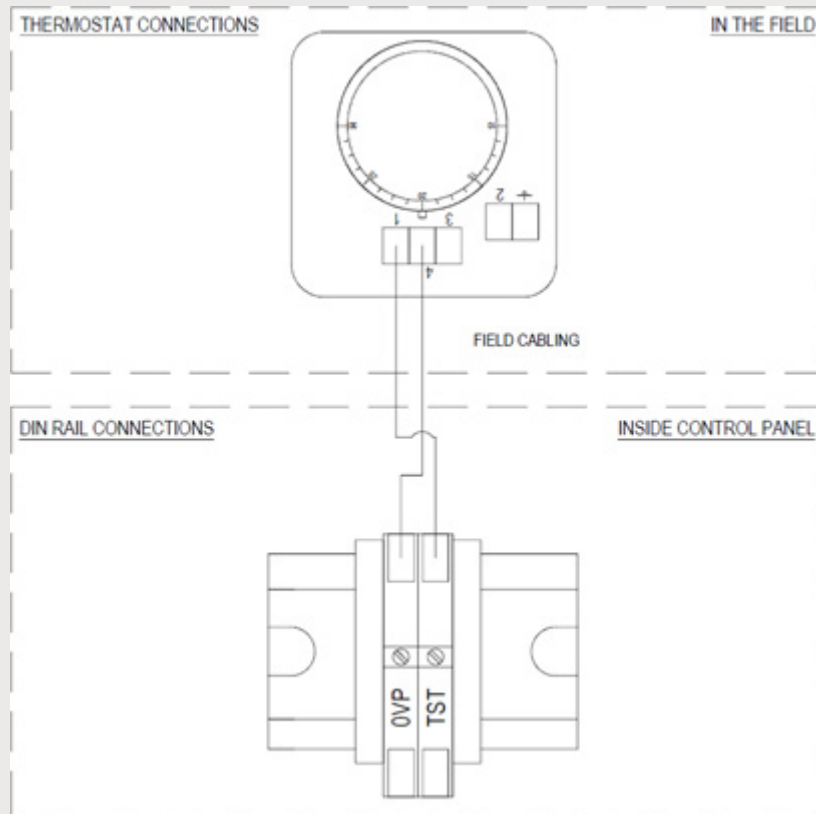

### 3.8. BMS Input (AI1, AI2)

A BMS input channel is provided. It has a 100K input impedance plus a 50ms anti-aliasing filter. By default, the input is configured to set the actuator position in 10% steps based on a scaling of 1V=10%, where 100% is the natural ventilation maximum run time (default 18 seconds).

Other input scaling is available. Please refer to SE Controls for details.

A second analogue input, AI2, having the same characteristics as AI1 is available. This is not used in the default system configuration.

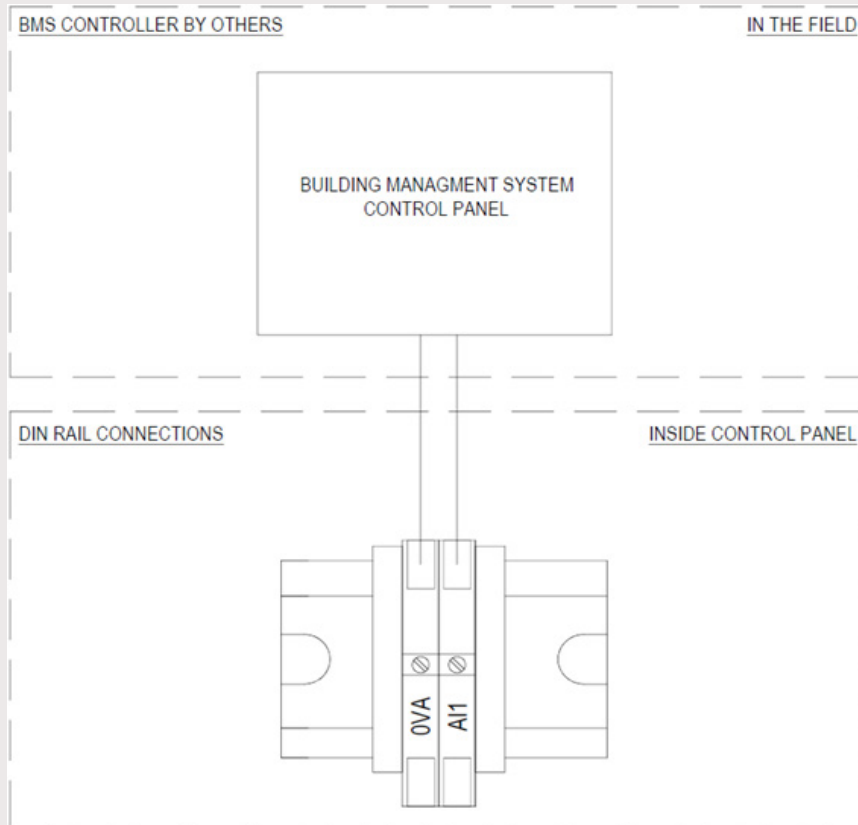

### 3.9. Rain Sensor (RNS)

An input for the connection of a volt free normally open rain sensor is provided. When the contact closes, power is applied at the actuator outputs in the close direction for a period of 180 seconds.

At the same time, a 180 second lock-out timer is started. If either the rain sensor remains wet or the lock-out timer is running, the natural ventilation controls are ignored. Once the rain sensor dries out and the lock-out timer times out, the natural ventilation controls are re-enabled. However, note that the position of the vent is not automatically reset to the last know position prior to the rain sensor activation.

**The rain sensor input can also be used to close the vents from a centralised control point, by the use of a 7-day timer or a caretaker switch.**

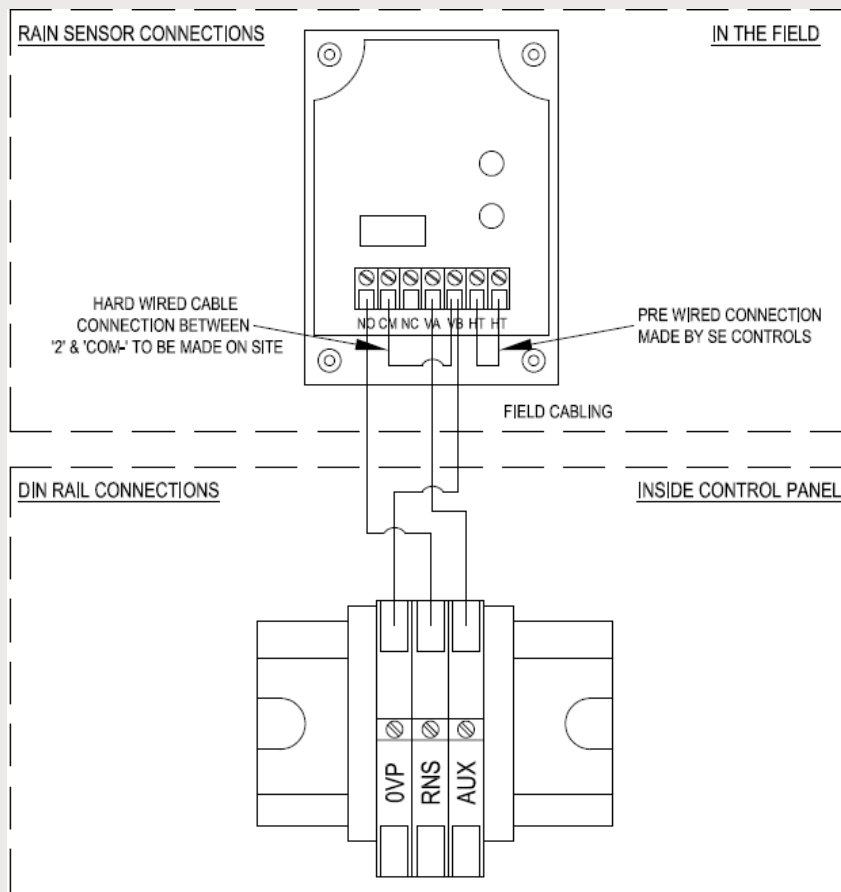

### 3.10. Network Connection (NTA, NTB, SCR)

Connections NTA and NTB are used for network connection with network interface plug in boards. The use of these devices is outside the scope of this document. Please refer to the individual product user manuals where necessary.

When used with the OSLink interface, ensure correct polarity of the connections.

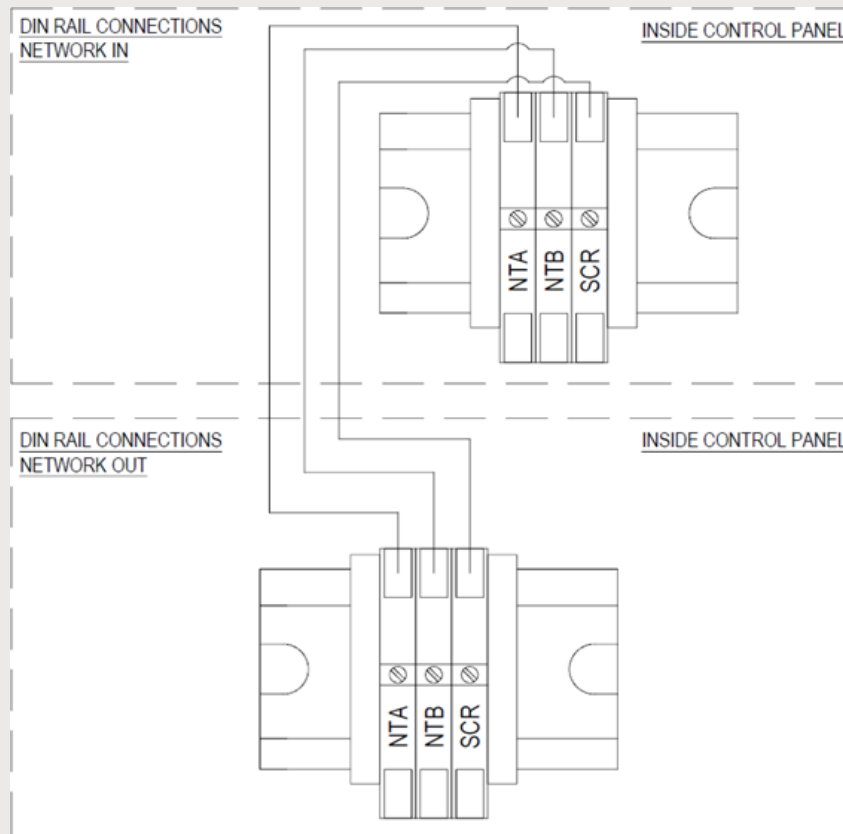

## 4. System Design

### 4.1. System Design

Design of a smoke and heat control scheme is a technically complex task and needs to consider both national legal requirements and local fire/building regulations. This is beyond the scope of this document. If in doubt, consult SE Controls or approved agents who can give further guidance.

The system design documentation should include a 'Cause and Effect' list or similar to identify the essential smoke control functions of the system.

Before installation of any system, the following should be considered and documented where necessary.

### 4.2. Design Checklist for each OS2:

- **Location** : Installation is in a clean, dry, and secure location, accessible for maintenance.
- **Location** : Not installed in sealed enclosure.
- **Location** : Distance to the actuators. Cable voltage drop is proportional to cable length, so locating the panel far from the load may require heavier gauge of cable.
- **Environment** : The equipment must not be subject to very cold or excessively warm ambient temperatures.
- **Electrical Load** : Maximum total actuator current is within specification (<16A).
- **Electrical Load** : Standby current on PER less than 40mA if 72Hour standby time is required.
- **Electrical** : Provision of locally fused, isolatable mains power supply
- **Communication options** : OSLon for LonWorks, OSLink card for OSLink networks or stand-alone
- **Smoke ventilation function** : None/open on fire/close on fire/top-of-smoke-stack/stairwell.
- **Smoke activation source** : smoke detectors / fire alarm interface / none / MCP.
- **Smoke activation reset** : Automatic or manual reset. MCP required for reset.
- **Natural ventilation function** : Day-to-day switch required.
- **Natural ventilation function** : Thermostat, NVLogiq, building management system (BMS).
- **Natural ventilation function** : Rain Sensor (Local / Networked)
- **Special Parameter settings** : Actuator run times, service due indication
- **Special requirements.**

### 4.3. Design Checklist for each MCP:

MCPs are fitted to OS2 SHEVTEC systems to indicate the fire state and allow control of the vent at high priority.

- Is an MCP is needed on each OS2 and where it might best be installed - The MCP control may or may not need to be accessible by fire service personnel. For natural ventilation systems, MCPs are often not required
- Vent finger trap risk. Is it required for vent to be visible from the MCP position.
- Type of MCP : Standard MCP (reset + open function) or tamperproof (reset only) MCP.
- Access to fixing screws and memory key slot. Allow a minimum of 150mm away from any obstruction below.
- Number of reset keys supplied to customer.
- Top of smoke shaft vents normally automatically reset, so often do not require an MCP.
- Where the MCP is solely used to reset or test the system, the MCPs can be located in a hidden or secure place.

### 4.4. Design Checklist for each Actuator/Vent

- Risk of crushing; this equipment can automatically close windows and vents without warning. Risk of severe injury from crushing of hands or fingers. Consider if additional protection (e.g., PIR proximity sensors, physical guarding, controlled force actuators) might be required.
- Compatibility : OS2 motor drive output voltage varies with input mains voltage and has considerable voltage ripple at heavy loads. Consult SE Controls when using non-SE Controls approved actuators.
- Cable voltage drop : Calculation of acceptable voltage drop may be required for heavy loads or long cables.

## 5. Installation, Commissioning and Fault-Finding

### 5.1. Pre-Installation

Hold the panel against the surface to which it is to be fixed. Mark through the holes. Drill appropriate sized pilot/fixing holes and use plastic plugs/cavity fixings where appropriate. Use 4 x 10mm bolts to secure the panel firmly.

- Installation of the panel in very warm locations (e.g. boiler rooms, hot plant rooms) should be avoided as high temperatures will reduce battery life. Temperatures should generally be below 35°C and never exceed 40°C. Avoid installation adjacent to boilers, hot water pipes, etc.
- The panel must be firmly fixed to a solid surface. The panel can be mounted on any vertical surface such as a wall. The panel must be accessible for maintenance.
- Locating the panel a long distance from the actuator will increase cable voltage drops on long cables, and may require use of more expensive cables with greater cross-section. In exceptional circumstances, charging the batteries can liberate gases. The panel must not be installed in a sealed cabinet or un-ventilated space.

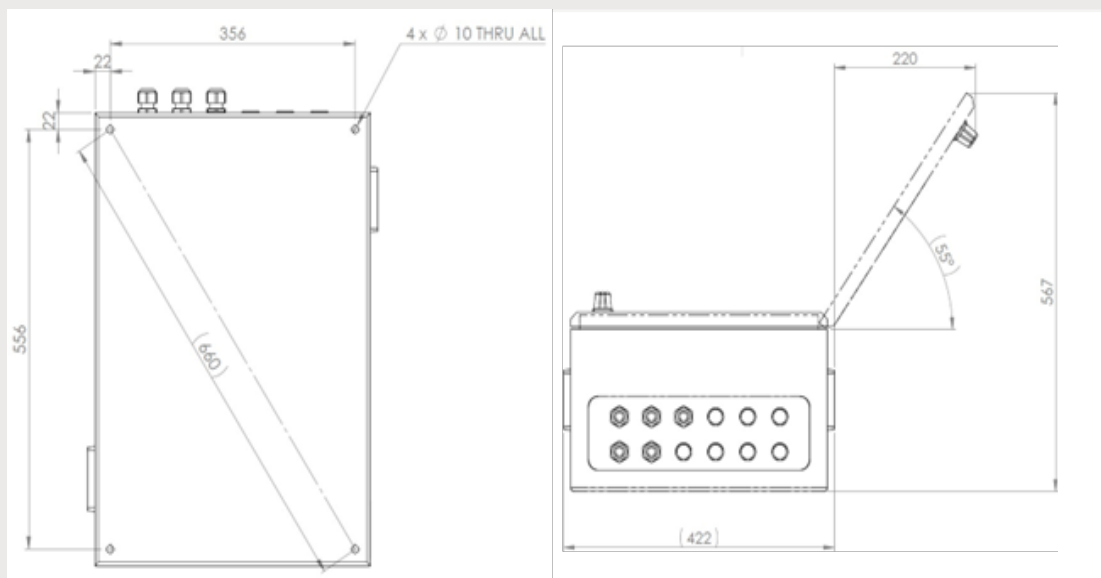

- The OS2 must be accessible for maintenance.
- We do not recommend fitting the OS2 inside a smoke shaft without additional protection, and must never be installed in the smoke shaft higher than the lowest floor.
- Locating the OS2 a long distance from the actuator will increase cable voltage drops on long cables, and may require use of more expensive cables with greater cross-section.
- In exceptional circumstances, charging the batteries can liberate gases. The OS2 must not be installed in a sealed cabinet or un-ventilated space.

## 5.2. Low Voltage Connections

Make connections to the OS2 board as detailed in **Section 3**.

## 5.3. Mains Connection

Ensure the supply is securely isolated before connecting. Connect to the 'Live In' on the MCB and N screw terminals to a fused unswitched mains outlet, using FP Plus 1.5mm<sup>2</sup> 3 core cable.

**Note that the terminal entries have openings suitable for use with up to 2.5mm<sup>2</sup> cable.**

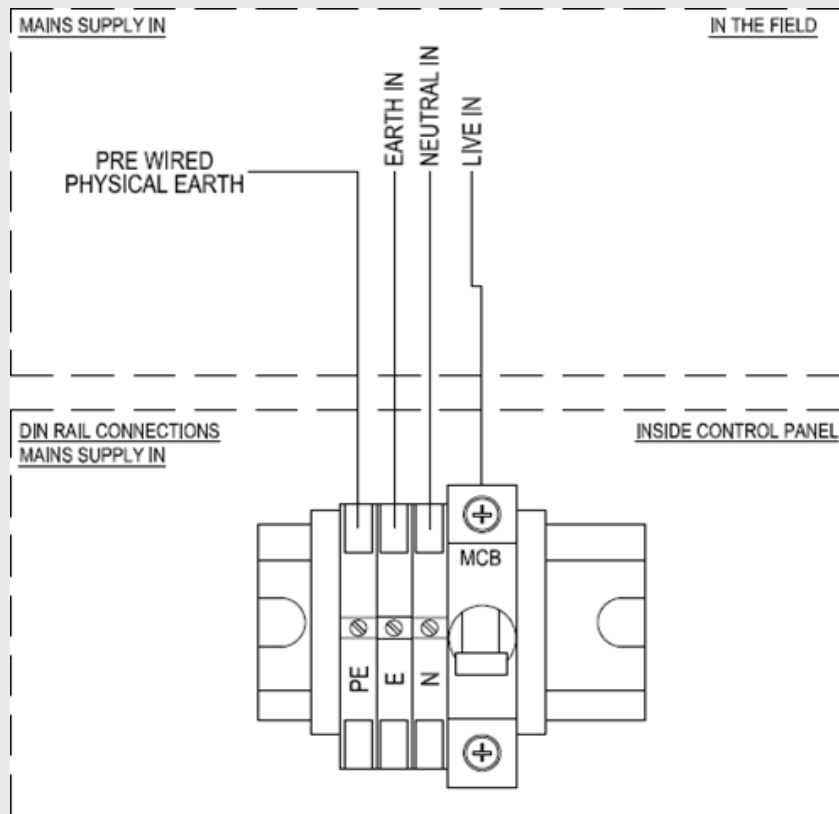

## 5.5. First Power-Up Test

Before powering up a system for the first time, ensure the actuator and vent installation is complete and operation of the actuators will not cause a hazard.

Full commissioning of a new system requires the availability of mains electrical supply. If activation is via a fire alarm-controlled relay, ensure the fire alarm system is reset.

With mains power removed, use a multimeter to measure the open circuit voltage on each battery. Check that the voltage is more than 10.5V for a new discharged battery, and more than 12.6V for batteries that are fully charged. Where batteries have been left connected and deep discharged, there is the risk of internal damage to the batteries and should be replaced.

Reconnect the batteries before connecting the mains supply. The battery charging should start within 30 seconds and may be checked by measuring an increase in battery voltage.

The green standby LED on the OS2 enclosure should illuminate to indicate healthy and any connected MCP should show standby and no fault.

For networked systems, an unbound, faulty or disconnected OSlink or OSlon card may cause a fault indication. For OSLink, check the green status led of the network, and if necessary re-initialise the network by pressing the button on the OSLink card.

Test the operation of the actuator by activation of the system. Ensure the actuator operates smoothly and adjust if necessary.

Where a 'Cause and Effect' functional specification is available, this will document a complete list of the required functions which must all be verified in turn. If this specification detail is not available, the commissioning engineer must ensure that each input is tested. This may require triggering of smoke detectors and simulating of fire alarm inputs.

If the system is not to be used for some time, ensure the system is left in the disconnected power- down state. If necessary, press the battery power down BPD button.

## 5.6. Basic Fault Finding

If the system operates from mains power but when mains power is removed will not operate from batteries, it is possible that the batteries will require replacement.

There are no user repairable parts. **Fault rectification must only be carried out by authorised and competent persons.**

- 1) Mains power: Incoming mains supply in the range 230 ±10% V ac must be present.
- 2) Fuses: Refer to section 2.6 – Do not replace fuses without investigating the cause of the failure. Blown fuses must be replaced with fuses of the correct type and current rating.
- 3) Battery open circuit voltage: The voltage on each battery when not on charge should be above 12.6 V dc
- 4) Cable connections: all connections to be secure and show no sign of damage or shorting
- 5) MCPs; All controllers have green 'healthy' indicators –refer to section 2.3 and 2.4

Symptom	Possibility
Standby LED off, fault flash (50/50) at MCP controller	Mains supply failed – check supply, fuse 1 and fuse in EMC filter.  Battery Failed. Disconnect the battery and check the open circuit voltage of each battery is >12.6V (fully charged) or >10.5V (uncharged). Replace pair of batteries if either is low.  Disconnecting and reconnecting the battery while mains power is applied can cause a battery fault to be wrongly detected even with a good battery. This fault is only cleared at the end of the fast-charge period so may take minutes or hours to clear. To avoid this, connect batteries before connecting mains power.
Standby LED on, brief fault blink every 10 seconds at MCP controller. System remains operational.	Service due indication (where enabled). Resetting a service due warning requires an engineer with a POP service tool.
No operation, No LEDs illuminated.	Mains supply lost and battery low.  Check battery voltage >10.5V each battery. Try 'battery power up' button. Check fuses. Restore the mains supply.
No actuator operation but actuator LEDs on PCB illuminated.	Check connection to the actuator and operation of the actuator.
No actuator operation and actuator LEDs on PCB not illuminated.	For smoke stacks and similar networked systems, check that another vent elsewhere is not open and interlocking operation.  Check fuses 4 and 5 to actuator. If blown, check cable and actuator for cause of overload, before replacing.
No response to natural ventilation controls, but fire controls operate O.K.	Check mains supply is present – Natural ventilation functions can be disabled on mains failure.  Check the rain-sensor input is not active. Allow time for rain sensors delays to timeout.  Wait for internal timers to timeout, e.g. If day-to-day controls are operated, the thermostat input is disabled for the occupancy time.  As some lockout timers can be lengthy, it can be useful to reset the system by removing and re-applying all power to the system.
No power on PER permanent output	Check internal fuses.
No power on AUX output	Check internal fuse, check mains supply present.

## 5.7. Battery Replacement

Batteries must always be replaced as a pair with batteries of equivalent construction, size, and capacity (4 x 12V SLA 7.0AH).

It is highly recommended that mains power is isolated before changing batteries.

Remove the protective covers on the battery output terminals and connect the battery red lead to the red terminal of one battery and the black lead to the black terminal of the other battery.

Complete the circuit by connecting the orange link wire between the batteries using the unused battery terminals.

Replace the enclosure cover and reconnect the mains supply. Check for green indication of the standby LED, and no fault indication at any MCP.

## 5.8. OS2 Panel Exterior Design

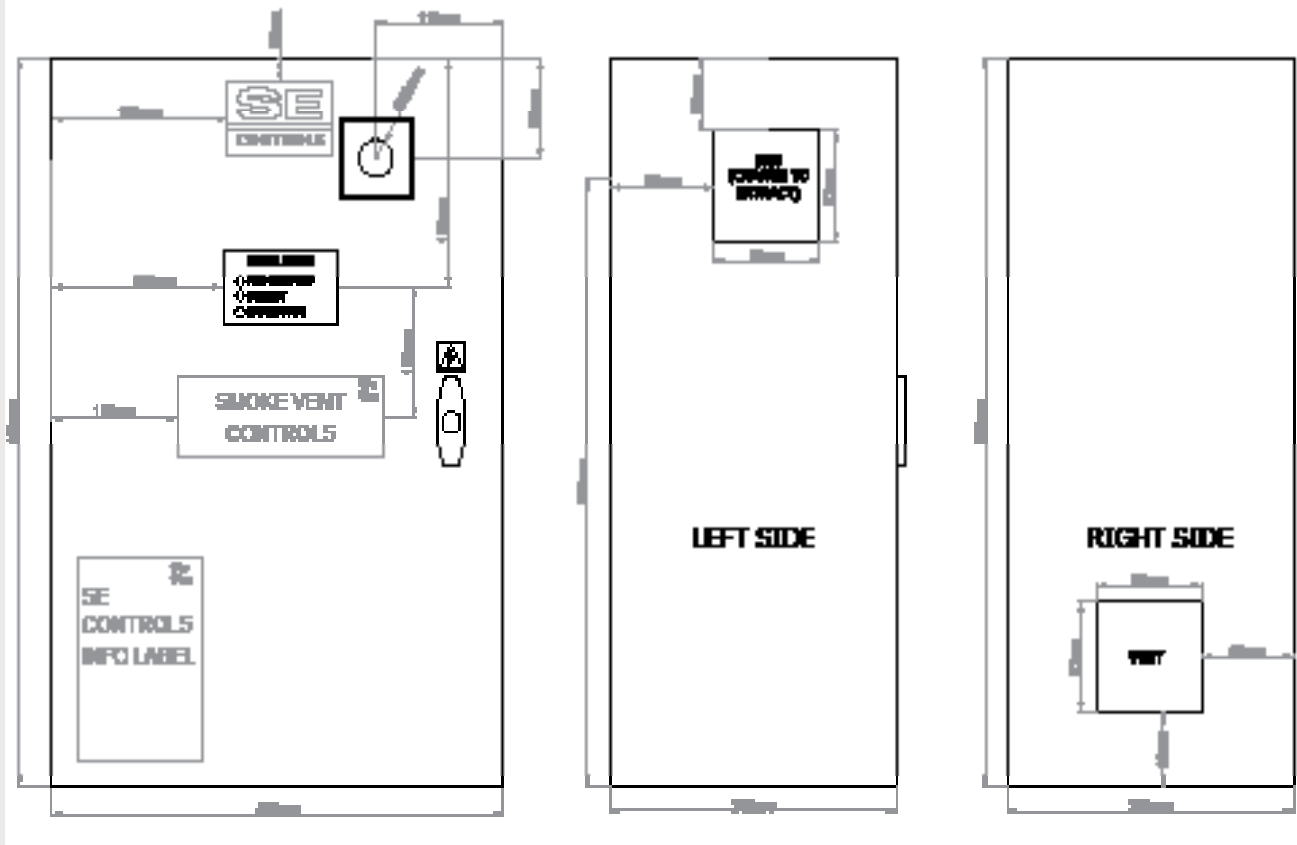

## 5.9. OS2 Panel Interior Layout

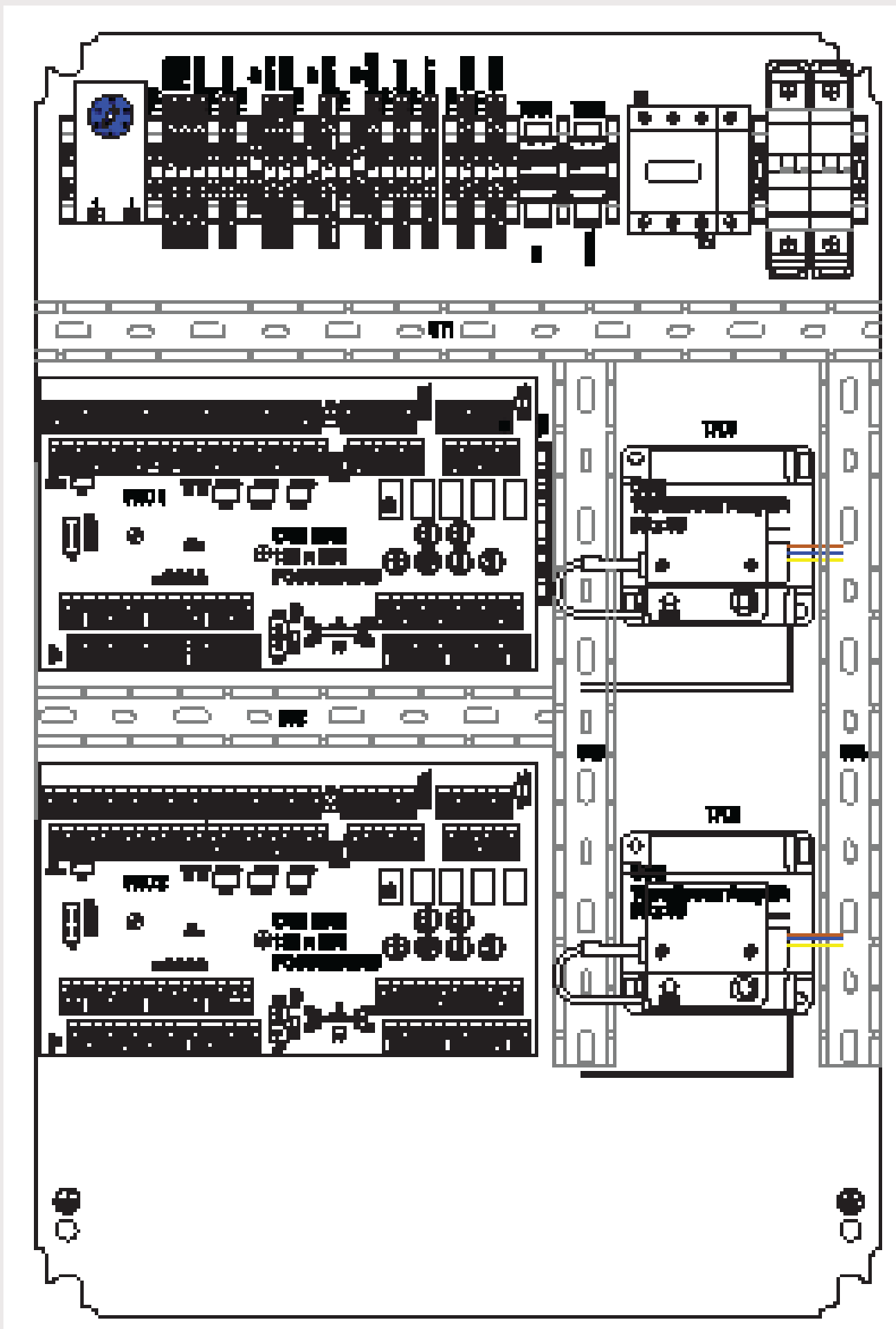

Please keep these operating instructions for future reference and maintenance. Subject to technical modifications. Diagram is not binding.

+44 (0)1543 443060  
sales@secontrols.com  
www.secontrols.com



Creating a healthier & safer environment

Lancaster House  
Wellington Crescent  
Fradley Park, Lichfield  
Staffordshire WS13 8RZ

**+44 (0)1543 443060**  
**sales@secontrols.com**  
**www.secontrols.com**

