

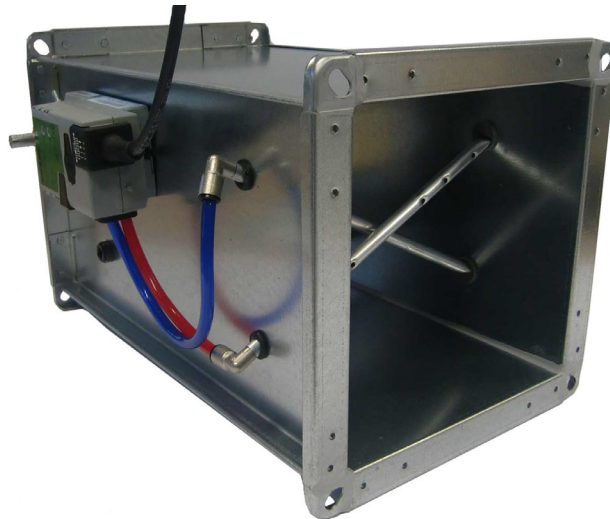

Volumetric Flow Controller

Model VRA-Q Smart®



Ferdinand Schad KG
Steigstraße 25-27
D-78600 Kolbingen
Telephone +49 (0) 74 63 - 980 - 0
Fax +49 (0) 74 63 - 980 - 200
info@schako.de
www.schako.de

Volumetric Flow Controller Model VRA-Q-Smart®

Contents

Description	3
Field of application	4
Installation	4
Construction	5
Model	5
Accessories	5
Models and dimensions	5
Dimensions	5
Dimensions of accessories	5
Technical data	7
Volumetric flow range	8
Technical data for Belimo components	9
Operating control Belimo components	9
Circuit diagrams	10
Setting the operating potentiometers / calculation formulae	12
Technical data of the controller	13
Functional control	13
Startup using PC-Tool	14
Startup using the setting and diagnostic device ZTH EU (Belimo)	15
Maintenance and service	16
Legend	16
Order details	17
Specification texts	17

Volumetric Flow Controller Model VRA-Q-Smart®

Description

The VRA-Q-Smart® volumetric flow controller impresses with its simple design, high measuring precision and short length, meeting the majority of customary requirements of volumetric flow controllers.

- simple design in accordance with the nominal size of the air duct.

This simple design saves a lot of time and provides planning safety.

- high controlling precision
Due to its high controlling precision, the controller requires a straight flow section of only $1 \times D$ even after bends.
- Blades sealing airtight to DIN EN 1751, Class 3
- Housing leakage air flow to DIN EN 1751, class B
- Damper axle support made of maintenance-free plastic
- in-factory presetting of the controllers

The controllers have been calibrated and preset in factory: this in-factory presetting eliminates later setting operations on-site. However, if a change must be made later on, the V_{\min} and V_{\max} settings can be simply adjusted using the ZTH-EU setting device. For the calibration of the controllers, a curve with a flow rate of 12 m/sec. is available. For constant-volume volumetric flow controllers, the V_{\min} value will be set to the desired constant-volume value.

- Tamper-proof
Since an on-site change in the volumetric flows can only be done via the ZTH-EU, the controller is tamper-proof. Simple rotary potentiometers are not tamper-proof!
- no later on-site volumetric flow controller setting necessary.
By virtue of the in-factory presetting, the on-site builder saves the time required for on-site setting of the volumetric flow controllers. Accordingly, the responsibility for setting the volumetric flow controllers is not just passed on to the on-site builder. This also reduces the on-site time pressure, since the controllers do not have to be set on-site.
- Functional check possible via the ZTH-EU.
The VRA-Smart® volumetric flow controllers have already been checked in-factory for their function. When the amount of air changes on-site, a functional check can simply be carried out by using the ZTH-EU.
- simple change in the amount of air via the ZTH-EU setting device

If the amounts of air preset in-factory must be adapted on-site, this can be simply done by using the ZTH-EU. When the controllers are mounted in false ceilings, the ZTH-EU can be simply inserted, and the setting and check can be done comfortably inside the room. This is an advantage compared with changing the settings of potentiometers, because the potentiometers in false ceilings are often hard to get to and difficult to see. If the changes in air volume are so large that the calibration curve must be changed, the controllers must either be recalibrated in-factory or the calibration curve must be changed on-site by the customer service of Schako.

- Covers the majority of customary requirements
 V_{\min} , V_{\max} and V_{konstant} controls possible, as well as positive control "Closed" or positive control "Open".
- Simple to connect
The controller contains the electrical wiring information. This avoids wiring faults.
- Protection type = IP 54
The controllers have the protection type IP 54. A strain relief for the cables has been integrated. For lower protection types, e.g. IP 20, mounting into ventilation systems or central units is not recommended.

The volumetric flow controller allows the volumetric flow in ducts to be kept constant or to be regulated using positive control V_{\min} , V_{\max} , "OPEN" or "CLOSED". The volumetric flow controller can also be used as a room or duct pressure regulator. In VAV systems the volumetric flow controller can regulate variable volumetric flows between V_{\min} and V_{\max} as a function of the supply air (room temperature controller). The volumetric flow setpoints V_{\min} and V_{\max} can also be altered at the controller at a later stage even after installation. Setpoints are initially set in-factory according to the customer's requirements. When these values are set in-factory, the functions of the volumetric flow controller are also checked. The V_{\min} and V_{\max} values can range from 0 to 100 % (with V_{\min}) and 30 to 100% (with V_{\max}). The measuring deviation is ± 5 %, based on V_{nein} . Volumetric flow controllers are in general insensitive to the inflow, owing to the built-in measuring rods. 6 measuring points are distributed on these measuring rods according to the median line method. In comparison with measuring rods having only four measuring points or measuring orifices, this gives optimum measurement results.

When using the controllers in systems with heavy dust contamination, suitable filters must be connected upstream. For polluted air, the volumetric flow controllers must be used with an integrated controller with a static membrane pressure sensor. In this case, it is imperative to observe the notice sign regarding the mounting position.

The volumetric flow controllers are not suitable for air containing sticky and greasy components.

For maintenance, service, retrofitting, etc., inspection openings in sufficient number and size must be provided on site.

Volumetric Flow Controller Model VRA-Q-Smart®

Field of application

- for supply and return air systems
- for constant or variable volumetric flows
- Positive control V_{min} , V_{max} , "OPEN" or "CLOSED"
- Suitable for constant and variable volumetric flow or duct pressure control
- Differential pressure range from 20 to 1000 Pa
- for duct velocities of 1 - 12 m/s
- for ambient temperatures of 0 - 55°C

When installing volumetric flow controllers, for example in roof central units, in extreme cases, condensation can build up in the measuring pipes of the volumetric flow controller as a result of the large temperature differences between the air flowing through the volumetric flow controller and the surrounding air. This condensation can affect the measuring element. In these cases, care must be taken that the casing of the volumetric flow controller and the measuring pipes are insulated, thus avoiding condensation.

Installation

Installation information

To avoid unnecessary controller errors, the min. distances according to the following table / drawings must be observed. For combinations of several connection pieces or pieces with fire dampers or silencers, the larger minimum distances must be observed.

All volumetric flow controllers can be assembled with horizontal or vertical damper axis.

Distance to:	VRA-Q-Smart®
Connection piece with bend	1 x diagonal
other connection pieces: (e.g. T-junction, branching piece, reduction piece, etc.)	2 x diagonal
Fire damper	2 x diagonal
Silencers:	2 x diagonal

Installation information for VRA-Q-Smart®

Distance to a connection piece with bend

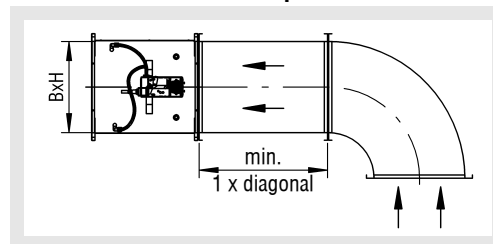

Distance to other connection pieces

(e.g. branching piece, reducing piece, T-junction, etc.)

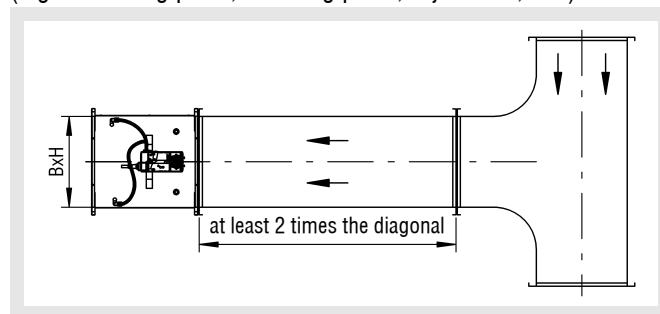

Distance to a fire damper

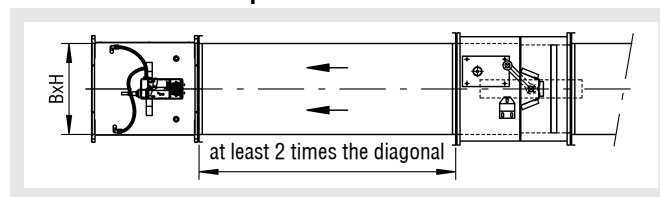

Distance to a silencer

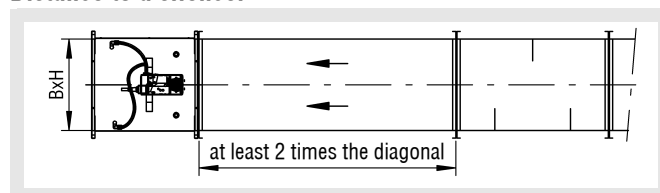

Volumetric Flow Controller Model VRA-Q-Smart®

Construction

Housing

- galvanised sheet steel
- Galvanised sheet steel with DD coating
- Stainless steel 1.4301 (V2A) or 1.4571 (V4A)

Blades

- opposed, made of extruded aluminium profile

Blade seal

- made of PUR, silicone-free
- for airtight design to DIN 1751, Class 3

Blade support

- plastic

Measuring rods

- aluminium (even with stainless steel model)

Model

VRA-Q-E Smart®

- Rectangular design, for duct connection to DIN 24190, with blade seal. (air-tight to DIN EN 1751, Class 3)
- Housing leakage air flow to DIN EN 1751, class B
- with electric controller LMV/NMV-D3-MF, not MP-bus-capable
- Control voltage 24 V AC 50/60 Hz
- Temperature compensation from 10 - 40°C

Accessories

Acoustic cladding (-DS)

- made of sound-absorbing, insulating 20 mm material with sheet steel covering made of galvanised sheet steel, non-flammable according to DIN 4102-17. In this model, each corner angle contains an M6 cage nut.

Setting and diagnostic device (-ZTH-EU, Belimo)

Mineral wool silencer (-ZSQ)

- Housing made of galvanised sheet steel. M2 metu profile on both sides.
- Baffle frame made of galvanised sheet steel
- Mineral fibre boards according to DIN 4102 A2, with glass filament cover, biosoluble, abrasion-resistant

Models and dimensions

Dimensions

VRA-Q-E-Smart®

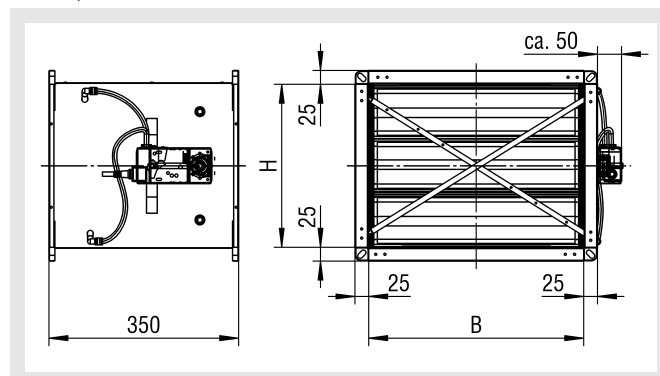

Dimensions of accessories

Acoustic cladding (-DS, insulation 20mm)

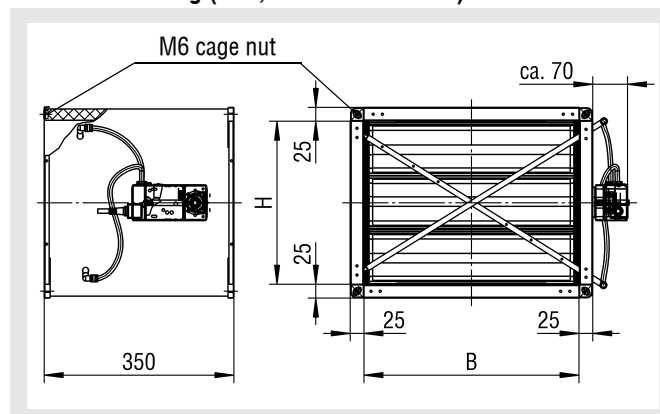

20 mm thick sound-absorbing material with sheet metal casing

Available sizes VRA-Q-E-Smart® / ...-DS

H	B												
	100	150	200	250	300	350	400	500	600	700	800	900	1000
100	X	X	X	X	X	X	X	X	X	-	-	-	-
200	-	-	X	X	X	X	X	X	X	X	X	-	-
300	-	-	-	-	X	X	X	X	X	X	X	X	X
400	-	-	-	-	-	X	X	X	X	X	X	X	X
500	-	-	-	-	-	-	-	X	X	X	X	X	X

x = available

- = not available

Volumetric Flow Controller Model VRA-Q-Smart®

Mineral wool silencer (-ZSQ)
with baffles type MVW

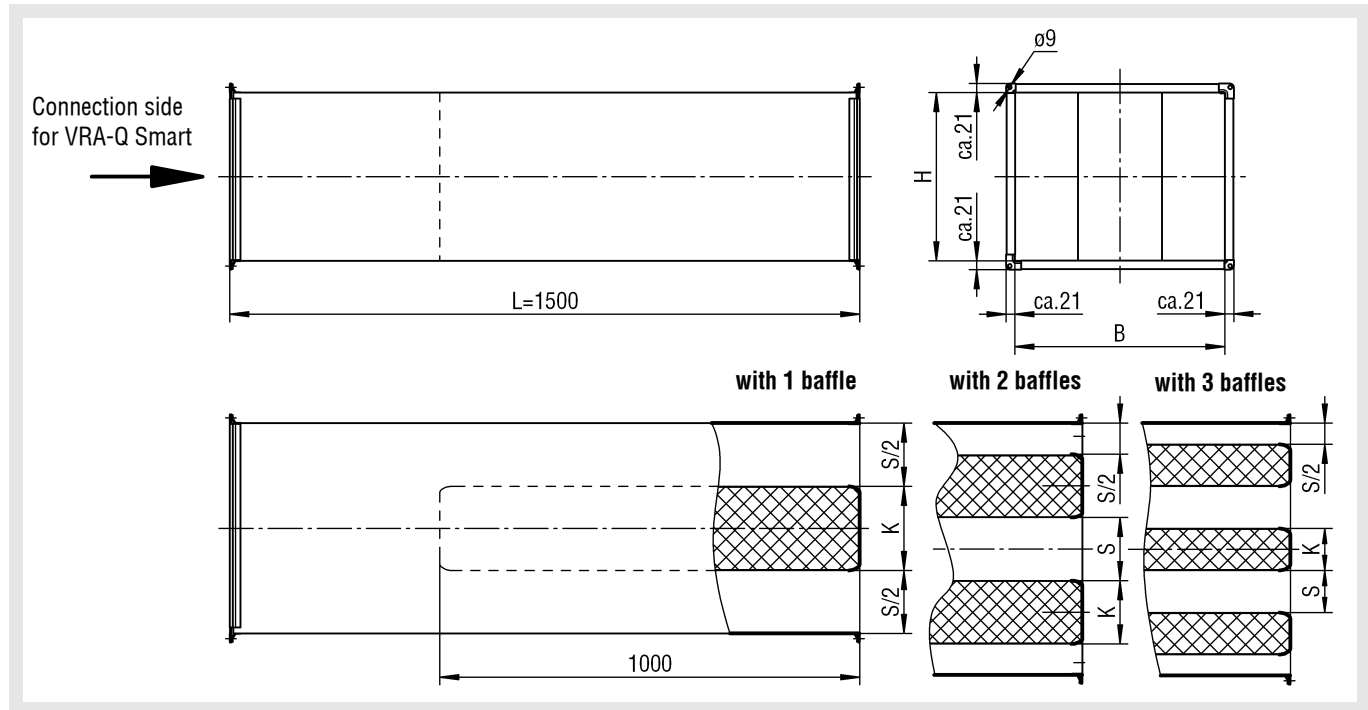

Available sizes and insertion loss
for mineral wool silencer (-ZSQ)

B (mm)	KA (-)	K (mm)	S (mm)	D_p [dB/oct]							
				f_m (Hz)							
				63	125	250	500	1000	2000	4000	8000
150	1	100	50	2	6	16	26	48	48	33	15
200	1	100	100	1	3	9	18	36	37	22	13
250	1	100	150	1	2	7	16	26	24	14	8
300	1	100	200	0	1	3	6	13	13	8	5
350	1	200	150	2	5	13	23	30	28	15	9
400	1	200	200	1	4	11	19	25	20	11	7
500	1	200	300	1	4	7	8	15	15	8	5
600	3	100	100	1	2	9	22	36	30	17	12
700	3	100	133	1	2	8	18	28	24	14	10
800	2	200	200	1	4	11	19	25	20	11	7
900	2	200	250	1	4	8	10	17	17	9	6
1000	2	200	300	1	4	7	8	15	15	8	5

The parameters KA (number of baffles), K (baffle strength) and S (gap width) depend on the width B.

Volumetric Flow Controller Model VRA-Q-Smart®

Technical data

Inflow area A (m²)

H (mm)	B (mm)												
	100	150	200	250	300	350	400	500	600	700	800	900	1000
100	0,01	0,015	0,02	0,025	0,03	0,35	0,04	0,05	0,06	-	-	-	-
200	-	-	0,04	0,05	0,06	0,07	0,08	0,10	0,12	0,14	0,16	-	-
300	-	-	-	-	0,09	0,105	0,12	0,15	0,18	0,21	0,24	0,27	0,30
400	-	-	-	-	-	0,14	0,16	0,20	0,24	0,28	0,32	0,36	0,40
500	-	-	-	-	-	-	-	0,25	0,30	0,35	0,40	0,45	0,50

Actuators

LMV-D3-MF
NMV-D3-MF

Flow generated noise (A = 1 m²)

v _k (m/s)	Δp _t = 100 Pa							Δp _t = 250 Pa							Δp _t = 500 Pa							Δp _t = 1000 Pa							
	L _{W1} [dB/oct]						L _{WA1} [dB(A)]	L _{W1} [dB/oct]						L _{WA1} [dB(A)]	L _{W1} [dB/oct]						L _{WA1} [dB(A)]	L _{W1} [dB/oct]						L _{WA1} [dB(A)]	
	f _m (Hz)							f _m (Hz)							f _m (Hz)							f _m (Hz)							
	125	250	500	1000	2000	4000	125	250	500	1000	2000	4000	125	250	500	1000	2000	4000	125	250	500	1000	2000	4000	125	250	500	1000	2000
3	62	61	60	59	56	52	63	68	68	67	67	65	63	72	74	74	73	73	71	69	78	81	82	81	81	80	77	86	
6	68	67	66	65	63	58	70	73	73	72	71	69	67	76	78	79	78	77	76	74	82	84	85	84	84	84	82	90	
9	73	73	73	71	69	65	76	79	78	78	76	75	73	82	79	80	81	80	80	78	86	86	88	87	87	86	85	92	
12	75	74	74	72	70	67	77	82	81	81	79	78	76	85	85	85	84	84	83	81	89	88	90	89	90	89	88	95	

Radiated noise (A = 1 m²)

v _k (m/s)	Δp _t = 100 Pa							Δp _t = 250 Pa							Δp _t = 500 Pa							Δp _t = 1000 Pa							
	L _{W1} [dB/oct]						L _{WA1} [dB(A)]	L _{W1} [dB/oct]						L _{WA1} [dB(A)]	L _{W1} [dB/oct]						L _{WA1} [dB(A)]	L _{W1} [dB/oct]						L _{WA1} [dB(A)]	
	f _m (Hz)							f _m (Hz)							f _m (Hz)							f _m (Hz)							
	125	250	500	1000	2000	4000	125	250	500	1000	2000	4000	125	250	500	1000	2000	4000	125	250	500	1000	2000	4000	125	250	500	1000	2000
3	69	61	55	48	44	41	58	75	68	62	56	51	50	65	82	75	68	53	58	53	72	90	82	77	72	67	60	80	
6	75	67	61	52	48	44	64	80	72	66	59	54	51	69	85	80	73	66	62	57	76	95	85	79	75	70	66	83	
9	80	73	67	57	53	49	69	85	75	70	61	58	54	73	86	81	75	67	65	61	77	96	87	82	76	71	69	85	
12	82	76	69	61	56	52	72	87	77	72	63	60	58	75	90	83	78	70	66	64	80	97	88	84	76	73	71	86	

Correction factor

(for flow generated and radiated noise)

A (m ²)	0,04	0,06	0,08	0,10	0,12	0,16	0,20	0,25	0,36	0,40	0,50	0,60	0,80	1,00
KF (-)	-14	-12	-11	-10	-9	-8	-7	-6	-5	-4	-3	-2	-1	0

Volumetric Flow Controller Model VRA-Q-Smart®

Volumetric flow range for VRA-R-E-Smart®

H (mm)	V		B (mm)													
			100	150	200	250	300	350	400	500	600	700	800	900	1000	
100	min.	(m ³ /h)	36	54	72	90	108	126	144	180	216	-	-	-	-	
		[l/s]	10	15	20	25	30	35	40	50	60	-	-	-	-	
	max.	(m ³ /h)	432	648	864	1080	1296	1512	1728	2160	2592	-	-	-	-	
		[l/s]	120	180	240	300	360	420	480	600	720	-	-	-	-	
200	min.	(m ³ /h)	-	-	144	180	216	252	288	360	432	504	576	-	-	
		[l/s]	-	-	40	50	60	70	80	100	120	140	160	-	-	
	max.	(m ³ /h)	-	-	1728	2160	2592	3024	3456	4320	5184	6048	6912	-	-	
		[l/s]	-	-	480	600	720	840	960	1200	1440	1680	1920	-	-	
300	min.	(m ³ /h)	-	-	-	-	324	378	432	540	648	756	864	972	1080	
		[l/s]	-	-	-	-	90	105	120	150	180	210	240	270	300	
	max.	(m ³ /h)	-	-	-	-	3888	4536	5184	6480	7776	9072	10368	11664	12960	
		[l/s]	-	-	-	-	1080	1260	1440	1800	2160	2520	2880	3240	3600	
400	min.	(m ³ /h)	-	-	-	-	-	432	576	720	864	1008	1152	1296	1440	
		[l/s]	-	-	-	-	-	-	120	160	200	240	280	320	360	400
	max.	(m ³ /h)	-	-	-	-	-	-	5184	6912	8640	10368	12096	13824	15552	17280
		[l/s]	-	-	-	-	-	-	1440	1920	2400	2880	3360	3840	4320	4800
500	min.	(m ³ /h)	-	-	-	-	-	-	-	900	1080	1260	1440	1620	1800	
		[l/s]	-	-	-	-	-	-	-	-	250	300	350	400	450	500
	max.	(m ³ /h)	-	-	-	-	-	-	-	-	10800	12960	15120	17280	19440	21600
		[l/s]	-	-	-	-	-	-	-	-	3000	3600	4200	4800	5400	6000

When the air volume drops below the V_{\min} shown in the chart, the correct functioning of the volumetric flow controller is no longer guaranteed!

Volumetric flow range

- If only one air volume is specified in the order (as V_{\max} value), the volumetric flow controller will be delivered as variable volumetric flow controller. The V_{\min} value will be set to the value specified in the catalogue.
- If only one air volume is specified in the order (as V_{\min} or V_{konstant} value or without specifying a value), then the volumetric flow controller will be delivered as a constant volumetric flow controller. The volume specified in the order is set to the V_{\min} value, and the V_{\max} value is set to 100%.
- The air volumes can be changed using setting devices specific for the controller make, depending on the calibration curve set ex works.
- For the parameter setting of the control components (all controllers), an air density of 1.2 kg/m³ has been taken into account.
- Belimo compact controllers are elevation-compensated. They are calibrated ex works to the respective system elevation of the specified installation site.
- If no system elevation is given in the order, the controllers will be calibrated to the elevation of the delivery address.
- If the customer does not specify whether the "Parallel" or "Master/Slave" operating mode is desired, the controller is set for the parallel operation (Master/Slave mode only upon customer request).

Volumetric Flow Controller Model VRA-Q-Smart®

Technical data for Belimo components

Measured value collection and control function

The measured values are collected by two measuring rods favourable to the flow. The measuring openings are distributed over the measuring rods according to the median line method. The pressure differential formed on the measuring rods is determined by means of a dynamic or static measuring sensor. From these measuring results the middle value is formed, which gives a measured variable for the volume flow. The controller compares the actual value signal with the set point and sends a start signal to the electric actuator which adjusts the controller deviation independent of pressure changes in the duct network.

Attention:

The volumetric flow controllers equipped with the Belimo control type LMV/NMV-D3-MF are delivered as standard with a SCHAKO 2 - 10 V DC drive (w-signal). Upon activation with 2 V DC, the V_{\min} volume is set. The V_{\min} volumes can be seen from the V_{\min} / V_{\max} tables. When the V_{\min} volume drops below the values shown in the V_{\min} / V_{\max} table, then the control function and the output of the U5 signal is no longer guaranteed for metrology reasons. Airtight sealing to DIN 1751 can be achieved by means of a 0V actuator signal or via a positive control. This positive control "CLOSED" must be implemented on-site via a switch contact.

Upon customer request, the volumetric flow controller equipped with the Belimo control type LMV/NMV-D3-MF can also be delivered with the drive 0-10 V DC. However, please note that in this case the positive control "CLOSED" can be implemented via a diode, see page 10.

Operating control Belimo components

Positive control damper "CLOSED"

Energy saving in areas not in use by closing the supply and return air volumetric flow controller. If the input Y is connected to terminal 1 (see page 10) via an on-site switch for the **operating range 2-10 V DC**, the drive will move the damper to the **CLOSED position**. The drive will also close the damper if the setpoint value for the minimum volumetric flow V_{\min} has been set to 0%, and the control signal corresponds to the value V_{\min} . This function does not correspond to the function of positive control "CLOSED" via the switch contact.

Positive control damper "OPEN"

Supports smoke extraction or is used as a safety position. The volumetric flow controller is in this case inactive, and the damper is driven to the mechanical open position.

V_{\min} control to min. volumetric flow

Depending on requirement or by not assigning them, individual areas can be set to stand-by operation. In this way, minimum room flushing with greatly reduced energy expenditure is achieved.

V_{\max} control to max. volumetric flow

Individual or several rooms are supplied for a short period with a maximum volumetric flow. This allows airing, night cooling and quick heating to be implemented.

Continuous operation

As a function of the continuous command signal and the programmed operating area (2 - 10 V; 0 - 10 V) the LMV/NMV-D3-MF will regulate the volumetric flow between the set values of V_{\min} and V_{\max} .

Constant operation

If terminal 3 (Y signal) has not been assigned, the air volume set on the V_{\min} potentiometer will be set to a constant volume.

VAV-Compact (LMV/NMV-D3-MF)

The operation control is effected via the drive input w/z. The possible functions depend on the selected operating mode "2-10 V" or "0-10 V". The diagrams below show the possible settings.

Volumetric Flow Controller Model VRA-Q-Smart®

Circuit diagrams

Compact controller Belimo make LMV/NMV-D3-MF - Attention: not MP-bus-capable VAV with analogue command signal

VAV with lock (CLOSED)
Mode 2-10V DC

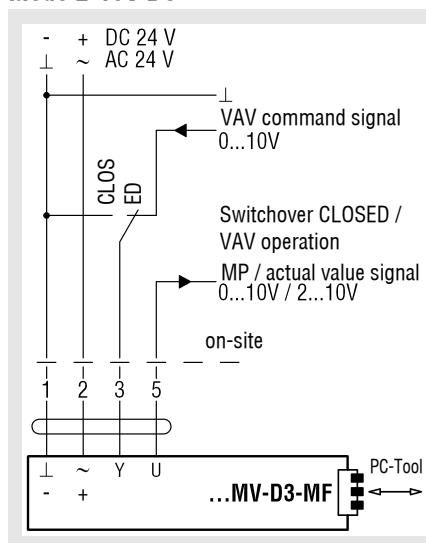
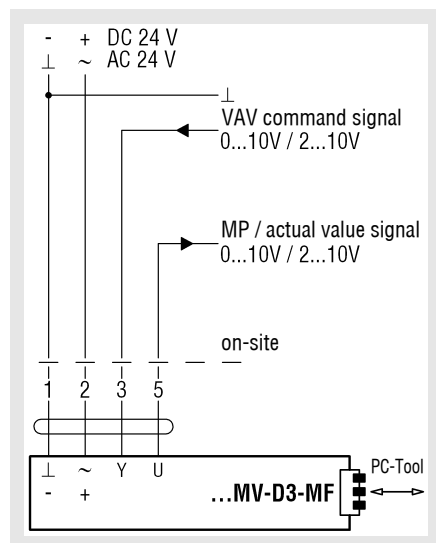

Cable designations

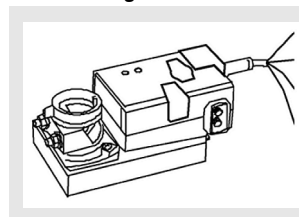

No.	Designation	Wire colour	Function
1	- ⊥	black	} Feed AC/DC 24 V
2	+ ~	red	
3	← Y	white	VAV / CAV command signal
5	→ U	orange	- Actual value signal

Lock mode (CLOSED)

In the 2 - 10 V mode, the following function can be carried with a 0 - 10 V signal:

Command signal Y	Volumetric flow	Function
< 0.1 V **	0	Damper CLOSED, VAV control inactive
0.2...2 V	V_{min}	V_{min} operating stage active
2...10 V	$V_{min} \dots V_{max}$	Continuous operation $V_{min} \dots V_{max}$

CAV operation / positive contacts

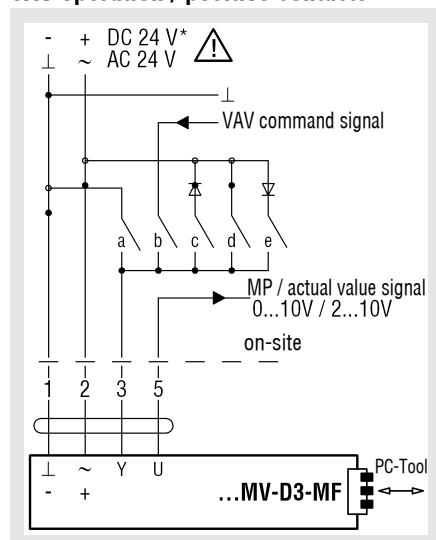

CAV function for LMV/NMV-D3-MF



Mode setting	---	0...10 V	0...10 V	0...10 V	0...10 V
Signal	⊥ -	0...10 V 2...10 V	~	~ +	~
Function					
Damper CLOSED		a) CLOSED	c) CLOSED*		
$V_{min} \dots V_{max}$		b) VAV			
CAV - V_{min}	everything open - V_{min} active				
Damper OPEN					e) OPEN*
CAV - V_{max}			d) V_{max}		



- Contact closed, function active
 - Contact closed, function active, in mode 2 ...10 V only
 - Contact open
- * not available for DC 24 V supply

Note: Please ensure mutual locking of the contacts!

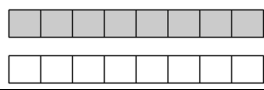
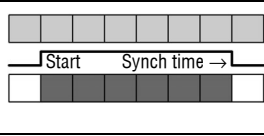
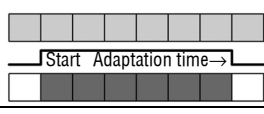
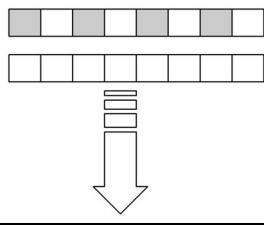
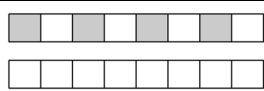
Volumetric Flow Controller Model VRA-Q-Smart®

LED table of functions for LMV/NMV-D3-MF

Application	Function	Description / action	LED pattern	Adaptation Address	⊕ LED 1 power ⊕ LED 2 status
N1 operation	Status display	- 24V power supply o.k. - VAV-Compact ready for operation	LED 1 LED 2		
S1 service function	Synchronisation	Synchronisation started by: a) Operating / service unit b) Manual trigger device at the VAV-Compact c) Power ON behaviour	LED 1 LED 2		
S2 service function	Adaptation	Adaptation started by: a) Operating / service unit b) Key on the VAV-Compact	LED 1 LED 2		
V1 VAV service	VAV service active	a) Press both keys «Adaptation» & «Address» simultaneously b) VAV service will be activated - until 24V supply is switched off - until both keys are pressed again - after 2 hours have passed	LED 1 LED 2		
	Lack of air	Damper opens as actual volume is too low	LED 1 LED 2		
	Target volume reached	Control circuit balanced	LED 1 LED 2		
	Air excess	Damper closes as actual volume is too high	LED 1 LED 2		

-  green LED (power) is lit
-  yellow LED (status) is lit
-  yellow LED (status) is flashing

Volumetric Flow Controller Model VRA-Q-Smart®

Setting the operating potentiometers / calculation formulae

Set value for V_{max}

$$EW_{V_{max}} = \frac{V_{max}}{V_{nenn}} \times 100\%$$

The required volumetric flow that is to flow at the 10 V DC command signal at terminal 3 (Y) or with positive control V_{max} is set in % at the V_{max} potentiometer of the controller, the ZTH-EU or PC-Tool. This value refers to the set V_{nenn} nominal volumetric flow.

Set value for V_{min}

$$EW_{V_{min}} = \frac{V_{min}}{V_{nenn}} \times 100\%$$

The required volumetric flow that is to flow at the 0 V DC command signal (operating mode 0-10 V DC) or at the 2 V DC command signal (operating mode 2 - 10 V DC) at terminal 3 (Y) or with positive control V_{min} is set in % at the V_{min} potentiometer of the controller, the ZTH-EU or PC-Tool. This value refers to the set V_{nenn} volumetric flow.

Calculation of the U_5 voltage value

Operating mode: 2 - 10 V DC:

$$U_5 = \frac{V_{max}}{V_{nenn}} \times 8V + 2V \quad V_{max} \text{ values}$$

$$U_5 = \frac{V_{min}}{V_{nenn}} \times 8V + 2V \quad V_{min} \text{ values}$$

Operating mode: 0 - 10 V DC:

$$U_5 = \frac{V_{max}}{V_{nenn}} \times 10V \quad V_{max} \text{ values}$$

$$U_5 = \frac{V_{min}}{V_{nenn}} \times 10V \quad V_{min} \text{ values}$$

Calculation of the V_{nenn} volumetric flow

$$V_{nenn} = EK \times F \times 3600 \quad [m^3/h]$$

Attention: The V_{nenn} value changes as a function of the set calibration curve.

The calibration curve is usually 12 m/s. Upon customer request, a smaller value can be selected.

- EW (%) = Set value
- EK (m/s) = Calibration curve
- U_5 (V DC) = U_5 signal
- F (m²) = Area

Actual value measurement via feedback signal U_5 using a voltmeter or PC-Tool

LMV/NMV-D3-MF

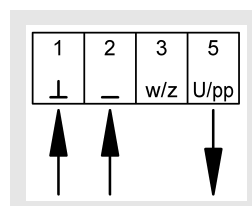

Supply voltage: 24 V AC/DC (Terminals 1+2)
 Measurement output 2 - 10 V DC (Terminals 1+5)
 Measurement output 0 - 10 V DC (Terminals 1+5)

The actual value signal U_5 is a real feedback of the volumetric flow actual value for monitoring and controlling the air throughput volume.

U_5 signal 0-10 V DC

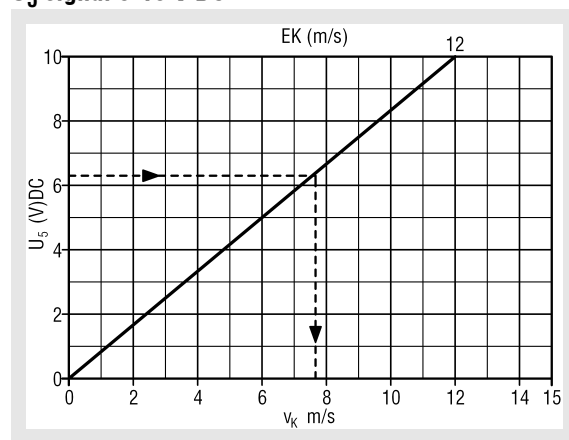

Example

Assume: Measurement output signal $U_5 = 6.3$ V DC
 Calibration value VRA-E = 12 m/sec
 Measured value: Duct velocity = 7.6 m/s
 Air volume: Duct velocity x area m² x 3600 = m³/h

U_5 signal 2-10 V DC

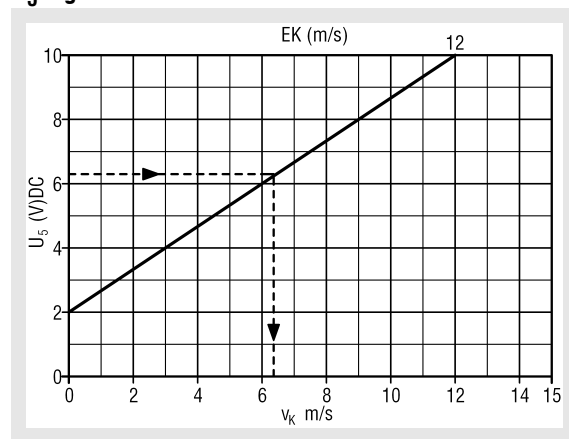

Example

Assume: Measurement output signal $U_5 = 6.3$ V DC
 Calibration value VRA-E = 12 m/sec
 Measured value: Duct velocity = 6.3 m/s
 Air volume: Duct velocity x area m² x 3600 = m³/h

Volumetric Flow Controller Model VRA-Q-Smart®

Technical data of the controller

LMV/NMV-D3-MF (make Belimo)

Dynamic pressure sensor, digital VAV controller and damper drive VAV-Compact solution

Measuring principle:	Pressure reading with through-flow
Measuring range of the sensor:	2... ~ 450 Pa
Supply voltage:	AC 24 V 50/60 Hz; DC 24 V
Functional range:	AC 19.2...28.8 V; DC 21.6...28.8V
Power consumption:	2 W / 3W
Dimensioning:	3.5 VA / 5 VA
Torque:	min. 5 Nm at the rated voltage
Control function :	VAV / CAV / Open-Loop; Supply/return air or stand-alone operation; master/slave parallel circuit; Mixing box control
Setting range V_{min}/V_{max} :	$V_{min} = 0...100$ % of set V_{nenn} volumetric flow $V_{max} = 30...100$ % of set V_{nenn} volumetric flow
Command variable Y: (Input resistance min. 100 k Ω)	DC 2-10 V (4...20 mA with 500 Ω input resistance) DC 0-10 V (0...20 mA with 500 Ω input resistance) adjustable DC 0...10 V
Setting range actual value signal U_5 :	DC 2...10 V DC 0...10 V
Sensor connection:	Passive (Pt1000, Ni1000, etc.) and active sensors (0...10 V), for example temperature, humidity, 2-point signal (switching power 16 mA @ 24 V), for example switch, presence detector
Protection class:	III (safety extra low voltage)
Protection type:	IP 54 (hose-connected)
EMC:	CE according to 39/336/EEC
Measuring air and ambient temperatures :	0° C...+50° C, 5...95% rH, non-condensing
Storage temperature:	-20° C...+80° C
Sound power level:	max. 35 dB (A)
Operation and service:	plug-in via service socket / PC-Tool (from V3.1) / ZTH-EU
Communication:	PP, max. DC 15V, 1200 Baud
Connection :	Cable, 4 x 0.75mm ² , terminals
Weight:	approx. 500g / approx. 700g

Functional control

LMV/NMV-D3-MF: Functional control

Electrical connection

Apply supply voltage 24 V AC ($\pm 10\%$) to terminals 1 + 2.
Is the polarity of the system neutral conductor correct?

⇒ **No:** Check wiring according to the diagram. Check transformer power.

→ LMV-D3-MF 5 VA

⇒ **Yes:** ...MV-D3-MF / ZTH-EU

↓

LMV/NMV-D3-MF / ZTH-EU :

Has the ...MV-D3-MF been set to the correct operating mode? (Check using the connected setting device ZTH EU!)

⇒ **No:** Set the operating mode on the ZTH-EU and save it.

→ Operating modes: 0-10 V, 2-10 V

⇒ **Yes:** Drive

↓

Drive:

Use the ZTH-EU to set operating mode 2-10 V and connect terminals 1+3 of the LMV-D3-MF.

Does the drive move to the "CLOSED" position?

⇒ **No:** Contact VRA manufacturer.

⇒ **Yes:** V_{max}

↓

V_{max} :

Connect terminals 2+3 of the ...MV-D3-MF and disconnect U_5 connection to the ZTH-EU.

If the ...MV-D3-MF controls to V_{max} - Check actual value signal U_5 .

⇒ **No:** Check the V_{max} potentiometer on the ZTH-EU and compare the settings with the technical data on the VAV device.

→ If the drive moves to the "OPEN" position, and the maximum volume is not reached, then the duct pressure is too low.

⇒ **Yes:** Set the system-specific operating mode on the ZTH-EU.

Volumetric Flow Controller Model VRA-Q-Smart®

Startup using PC-Tool

Direct connection in the switch cabinet or socket
(traditional application)

ZTH EU as MP level converter



Description

The ZTH EU is also a potential-free interface between the USB port of a PC and the Belimo MP bus. It is used to connect the Belimo PC-Tool directly to the MP bus or directly to a programmable MFT drive.

Power supply

The ZTH EU is supplied with power by the USB port. The MP bus voltage is obtained internally by means of DC/DC converter. This is why no external power supply is necessary.

Driver

To be able to work with the ZTH EU, a suitable driver must be installed on the PC. The driver can be downloaded from the Belimo website (download section). After installation of the driver, the ZTH EU device will log in to the PC as a virtual COM interface.

Note

For connection to USB ports of PCs and BELIMO 24 V drives only (to safety extra low voltage SELV or US class 2 feeds).

Connection diagram 1

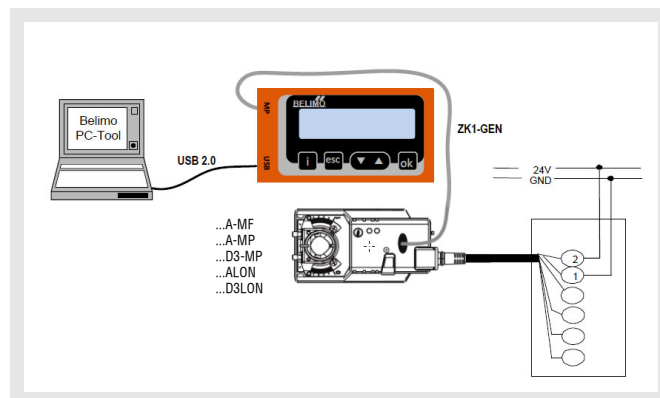

Local connection via a service socket of the MF/MP or LON drive using a ZK1-GEN cable.

Connection diagram 2

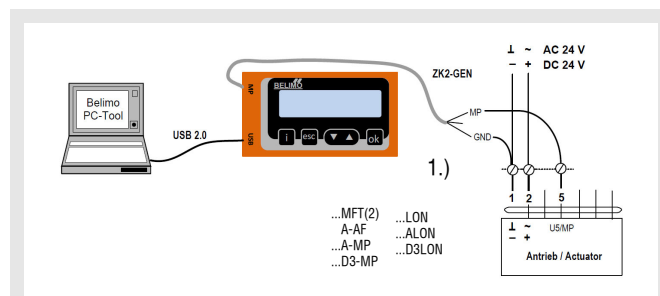

Local connection via a connecting cable of the MF/MP or LON drive using a ZK2-GEN cable.

- 1.) white = GND
green = MP
blue = not connected

Volumetric Flow Controller Model VRA-Q-Smart®

Startup using the setting and diagnostic device ZTH EU (Belimo)



Short description

The VAV setting device ZTH EU allows efficient testing of VAV and CAV installations. Installations fitted with the Belimo VAV controller can be simply adapted to the room and user requirements.

The VAV setting device ZTH EU replaces the previous setting device ZTH-GEN (2007-2014).

All standard Belimo VAV controllers with integrated PP communication (from 1992) that are sold in the EU can be set using the ZTH EU.

Specifications:

- easy, quick setting of the VAV boxes parameters
- diagnostic function
- one tool for all VAV units
- voltage supplied by VAV controllers - no batteries required!
- service socket VAV / CR24 controller, PP connection
- includes connecting cable RJ12 6/4, 6-pin plug
- New generation, MP bus tester
- for functional test of MP bus
- backward compatible with all Belimo PP / MP units from 1992
- efficient handling, can be operated with one hand
- Selection of stages for test (OPEN/CLOSE/MIN/MAX/STOP)
- Damper position indicator for diagnostics
- Display of the setpoint / actual volume and $V_{\min/\max}$ setting in m^3/s (l/s).

Keys / Display:



2 x 16-digit LCD with background lighting

- ▼▲ Forwards/Backwards
Change value / status
- OK Confirm input
- ESC Cancel input/
Leave submenu/ Discard changes
- i shows additional information if available

Connection:

Locally via service socket



Dimensions::

85x65x23 (WxHxD)

Connection and supply

Stand-alone operation:

Connection including supply takes place via the service socket at the VAV controller or via the terminals.

Bus operation:

The ZTH EU can be used in the following units while the bus is running if it is connected via the local service socket: VAV-Compact L/N/SMV-D3-MP, NMVAX-D3-MP, L/NMV-D3LON. With the VRP-M, L/NMV-D3-M and NMVAX-D3-MP, the MP-Bus must be disconnected when the service socket is used.

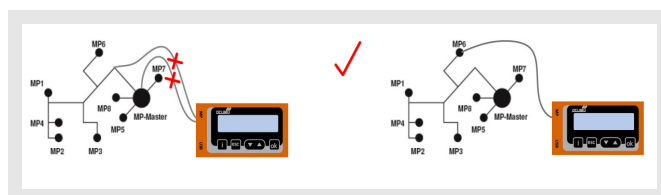

Restriction:

Direct connection in an MP network or via an MP-Bus master is not possible.

The ZTH EU comes with a quick start guide de/en to be affixed to the back of the unit.

Volumetric Flow Controller Model VRA-Q-Smart®

Maintenance and service

Assembly and maintenance instructions

1. When the device is delivered, check whether the controllers are complete and have been delivered without damage. Complaints have to be communicated immediately and directly to the transporter and SCHAKO.
2. The volumetric flow controller must not be carried on the regulation components, measuring cross or the damper leaf, but only on the housing.
3. The controllers must be carefully stored on-site. They must be protected from dust, dirt and from direct weather effects.
4. The controllers must be assembled in a way to allow inspection.
5. Assembly must be carried out by expert personnel, observing recognised technical rules and regulations.
6. **For polluted air, the volumetric flow controllers must be used with an integrated controller with a static membrane pressure sensor. In this case, it is absolutely necessary to observe the mounting position. The volumetric flow controllers are not suitable for air containing sticky and greasy particles.**

Legend

V	(m ³ /h) [l/s]	= Air volume
V _{min}	(m ³ /h)	= Minimum air volume
V _{max}	(m ³ /h)	= Maximum air volume
EW _{Vmax}	(m ³ /h)	= Set value of maximum air volume
V _{Nenn}	(m ³ /h)	= Nominal air volume
v _K	(m/s)	= Duct velocity
D _e	[dB/oct]	= Insertion loss
Δp _t	(Pa)	= Pressure loss
Δp _{t min}	(Pa)	= Minimum static pressure difference
L _W	[dB/oct]	= Sound power level/octave
L _{WA}	[dB(A)]	= A-weighted sound power level
f _m	(Hz)	= Octave band centre frequency
U5	(V) DC	= Measurement output (electric voltage)
NW	(-)	= Nominal width

Cleaning of the dynamic differential pressure sensor

The dynamic differential pressure sensor integrated into the **LMV/NMV-D3-MF** requires little maintenance. However, if, depending on the degree of pollution of the air, unexpected volumetric flow deviations occur, then the following procedure is recommended.

1. Pull off the pressure hoses from the sensor connection pipe of the LMV/NMV-D3-MF.
Attention! Make a note of the (+) and (-) assignments.
2. Using a suitable hand pump, blow air into the (-) connection piece of the sensor (this will blow any dirt deposited inside the sensor out of the (+) connection piece).
3. Remove any dirt that may have formed from the connecting pieces and hose ends.
4. Reconnect pressure pipes as before (+) and (-).
5. Carry out a functional check of the controller.

Volumetric Flow Controller Model VRA-Q-Smart®

Order details

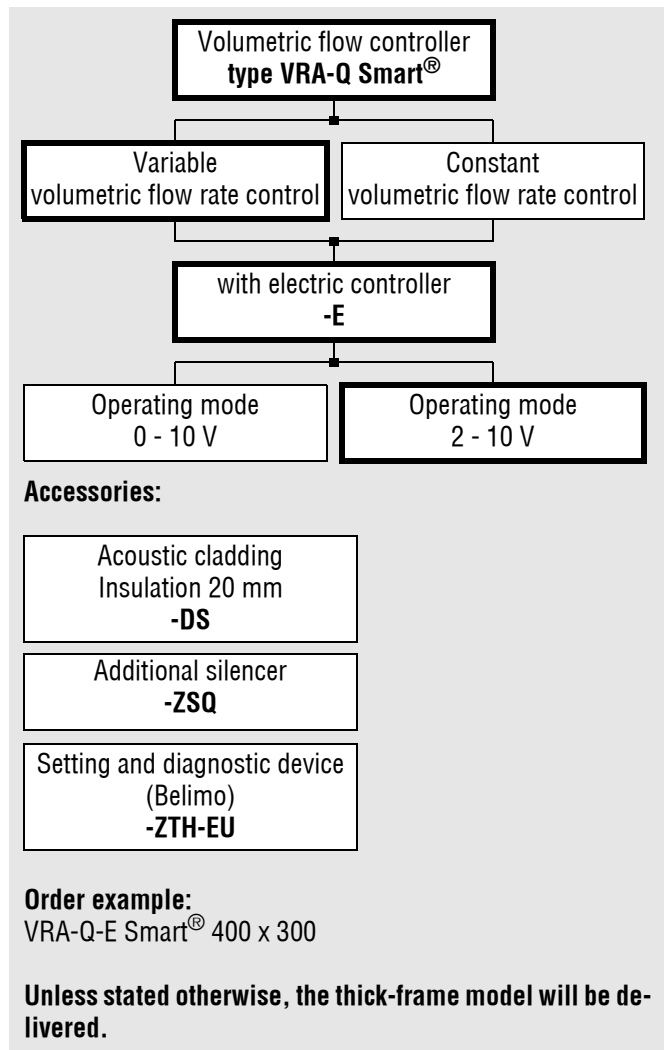

Specification texts

Volumetric flow controller in rectangular design, for duct connection to DIN 24 190, for use in supply and return air systems for constant or variable volumetric flow, room or duct pressure regulation. With positive control V_{\min} , V_{\max} or "CLOSED". Allowed pressure difference range: 50-1000 Pa, allowed ambient temperature 0-50°C. Suitable for use with duct velocities of 2-12 m/s.

It is possible to subsequently adjust the manufacturer set operation volume flow. The output signal can be used for master/slave or parallel operation of several controllers or for actual value display 2-10 V DC (0-10 V DC), which corresponds to 0-100 % of the set V_{nenn} in DDC/ZLT systems.

Housing made of galvanised sheet steel. Opposed blades, blades sealing air-tight to DIN EN 1751, Class 3, housing leakage air flow to DIN EN 1751, class B, made of aluminium. Measuring rods made of aluminium, blade support made of plastic. With electric controller LMV/NMV-D3-MF, control voltage 24 V AC, 50 / 60 Hz, requirement: measuring air 0...+50°C/5...95% rH, non-condensing, wired and adjusted in-factory. Right-hand design.

Product: SCHAKO type **VRA-Q-E-Smart®**

Housing (at an extra charge):

- galvanised sheet steel with DD coating (-DD)

Accessories (at an extra charge)::

- Acoustic cladding (-DS) made of 20 mm sound-absorbing material with sheet metal casing made of galvanised sheet steel, non-flammable according to DIN 4102-17. Includes M6 cage nuts at the corner angles.
- Mineral wool silencer (-ZSQ) with metu profile M2 on both sides, housing (L=1500) consisting of galvanised sheet steel with integrated MWK silencing baffles (L=1000). The MWK silencing baffles with RAL quality seal consist of abrasion-resistant mineral fibre boards covered with fibre glass filament (biosoluble, non-flammable to DIN 4102) in a frame of galvanised sheet steel. Baffles measured to ISO/DIS 7235 and to DIN 45646.
- Setting and diagnostic device ZTH-EU (Belimo)
- MP-bus-capable electric controller LMV-D3-MP, NMV-D3-MP