

Table of Contents

Areas of application	2
Useable volumetric flow ranges	2
Function	3
Processing	3
Available sizes / -dimensions	4
Accessorieslist VM-PRO-R/-Q	5
Dimensions of the accessories VM-PRO-R.....	6
Dimensions of the accessories VM-PRO-Q	8
Prior to assembly and commissioning	9
Installation - maintenance - service.....	9
Legend	10
VM-PRO - Minimum static pressure difference.....	11
VM-PRO-R - Controller position.....	12
VM-PRO-R - flow generated noise	13
VM-PRO-R - Radiated noise	14
VM-PRO-R - Radiated noise with acoustic cladding.....	15
VM-PRO-R - duct silencer (-RS) - insertion loss.....	16
VM-PRO-Q - Controller position	17
VM-PRO-Q - controller position (continued)	18
VM-PRO-Q - flow generated noise	19
VM-PRO-Q - Flow generated noise continued.....	20
VM-PRO-Q - Radiated noise.....	21
VM-PRO-Q - Radiated noise continued	22
VM-PRO-Q - Radiated noise with acoustic cladding	23
VM-PRO-Q - Radiated noise with acoustic cladding continued.....	24
VM-PRO-Q - mineral wool silencer (-ZSQ) - insertion loss.....	25
Specification text VM-PRO-R	26
Specification text VM-PRO-Q.....	26
Order details / order code	27

Areas of application

Volumetric flow controller for supply and return air systems, suitable for regulating a constant volumetric flow with the option of electrical setpoint adjustment (VM-PRO-R-E)

ATTENTION

The VM-PRO is an adjusted controller working by the mechanism of action principle. Tampering with the controller, whether manually or mechanically, are prohibited. When a high volumetric flow setting has been selected, the damper leaf must never be closed manually. Otherwise, the control mechanism will be changed, resulting in a loss of control accuracy. The field of application must always be complied with. If the VM-PRO is used beyond its allowed field of application, this will result in mechanical overload and thus in a loss of control accuracy.

We would like to point out that to clean the stainless steel design, only suitable corresponding cleaning materials must be used.

CORRECTION FACTORS REGARDING THE AIR VOLUMES

In controller positions 1 and 2, Δp must be >100 Pa.

For $\Delta p \leq 1000$ Pa deviations of up to 20% of the set value can occur.

Maximum deviation compared to the set value:

Air velocity 2-4 m/s $\pm 10\%$

Air velocity 5-6 m/s $\pm 8\%$

Air velocity 7-8 m/s $\pm 6\%$

Air velocity 9-10 m/s $\pm 5\%$

Scale accuracy $\pm 4\%$

Maximum deviation compared to the set value:: NW 80 from a static minimum pressure difference of p 100 Pa

Air velocity 3-4 m/s $\pm 20\%$

Air velocity 5-6 m/s $\pm 16\%$

Air velocity 7-8 m/s $\pm 10\%$

Air velocity 9-10 m/s $\pm 8\%$

Scale accuracy $\pm 4\%$

Useable volumetric flow ranges

Volumetric flow ranges for VM-PRO-R

NW (mm)	V_{ZU} (m ³ /h)		V_{ZU} [l/s]	
	min.	max.	min.	max.
80	50	170	14	47
100	70	260	19	72
125	120	420	33	117
160	180	700	50	194
200	250	1200	70	333
250	300	1500	83	417
315	450	2200	125	611
400	700	4200	195	1167

Volumetric flow ranges for VM-PRO-Q

B x H (mm)	V_{ZU} (m ³ /h)		V_{ZU} [l/s]	
	min.	max.	min.	max.
200 x 100	200	800	56	222
300 x 100	325	1075	90	299
300 x 150	250	1500	69	417
300 x 200	225	1800	63	500
400 x 200	500	2050	139	569
400 x 250	850	3200	236	889
400 x 300	700	3600	194	1000
400 x 400	900	4400	250	1222
500 x 200	650	3100	181	861
500 x 250	950	4200	264	1167
500 x 300	1200	4800	333	1333
500 x 400	1300	6200	361	1722
600 x 200	450	4100	125	1139
600 x 250	1200	4600	333	1278
600 x 300	1700	5800	472	1611
600 x 400	1900	8200	528	2278

For the parameter setting of the control components, an air density of 1.2 kg/m³ has been taken into account. When the air volume drops below the V_{min} shown in the chart, the correct functioning of the volumetric flow controller is no longer guaranteed.

Function

The constant volumetric flow controller VM-PRO works independently without requiring additional energy. The central, ball-bearing flap is moved by the air current. The control unit with control cam, spring and damper is attached to the outside of the galvanised sheet steel housing. The required volumetric flow is set in-factory. An adjustment of the volumetric flow at a later stage is possible (setting cam on housing). The control unit is protected with a cover. The controller can be assembled in any assembly position.

- Operating temperature: 10 - 50° C
- Differential pressure range 50 - 1000 Pa
- Housing leakage according to DIN EN 1751, class C

The mechanical volumetric flow controller VM-PRO-R-E / VM-PRO-Q-E with actuator is suitable for adjusting the supply or return air volume to varying room occupations. Should this become necessary, it can be done without removing the false ceiling.

As-delivered the volumetric flow controllers VM-PRO-E are set to V_{min} . The controller must be connected on-site to the power supply and then adjusted on-site to the desired controller position. The control unit including regulating curve, spring, damper and actuator is attached to the outside of the galvanised sheet steel housing. The required volumetric flow is set in-factory.

Thanks to the actuator, the volumetric flow controller can be adjusted without problems to the required volumetric flow within the controller range. If a mechanical limitation of the controller range by means of stops is selected for the drive, the following setting values are possible:

To avoid unnecessary controller errors, the information given on p. 9 should be observed. The setting values for actuators with constant control can be obtained from the controller settings. In OPEN / CLOSED actuators, the control setting is effected through a mechanical limit.

- Limit stops for a mechanical limitation can only be achieved in the scale ranges 1-7 and 3-10 (see also: controller setting table)

For maintenance, service, retrofitting, etc., inspection openings in sufficient number and size must be provided on-site. For room pressure regulation, we recommend electrical volumetric flow controllers VRA or room pressure controllers CRP.

Processing

Housing

Galvanised sheet steel (standard)
Galvanised sheet steel with DD coating
Stainless steel 1.4301 (V2A) or 1.4571 (V4A)

Control damper

Aluminium (VM-PRO-R- for NW ≤ 160)
Aluminium with DD coating (VM-PRO-R- for NW ≤ 160)
Galvanised sheet steel (VM-PRO-R- for NW > 160 | VM-PRO-Q-)
Galvanised sheet steel with DD coating (VM-PRO-R- for NW > 160 | VM-PRO-Q-)
Stainless steel 1.4301 (V2A) or 1.4571 (V4A), optionally to galvanised sheet steel at an extra charge

Control unit housing

Plastic, halogen-free
Stainless steel 1.4301 (V2A) or 1.4571 (V4A)

Available sizes / -dimensions

Sizes VM-PRO-R

Nominal size NW	øD	L
80	78	290
100	98	290
125	123	290
160	158	290
200	198	290
250	248	390
315	313	390
400	398	490

Dimension VM-PRO-R

Round design, for duct connection to DIN EN 1506, position-independent installation.

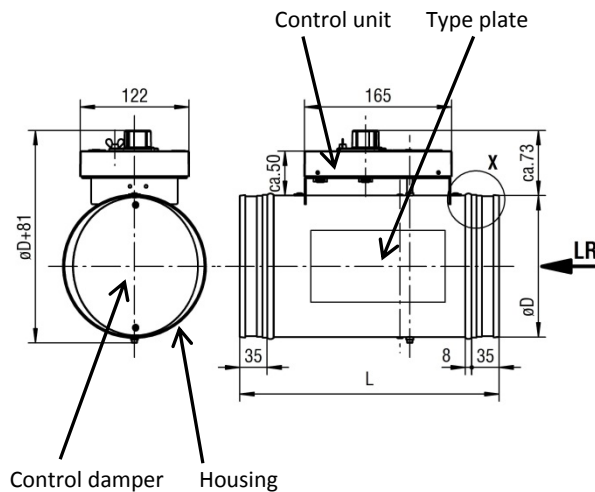

Sizes VM-PRO-Q

Height H	Width B				
	200	300	400	500	600
100	x	x	-	-	-
150	-	x	-	-	-
200	-	x	x	x	x
250	-	-	x	x	x
300	-	-	x	x	x
400	-	-	x ^{1.)}	x ^{1.)}	x ^{1.)}

Dimension VM-PRO-Q

Rectangular design, for duct connection to DIN 1505, right-hand design

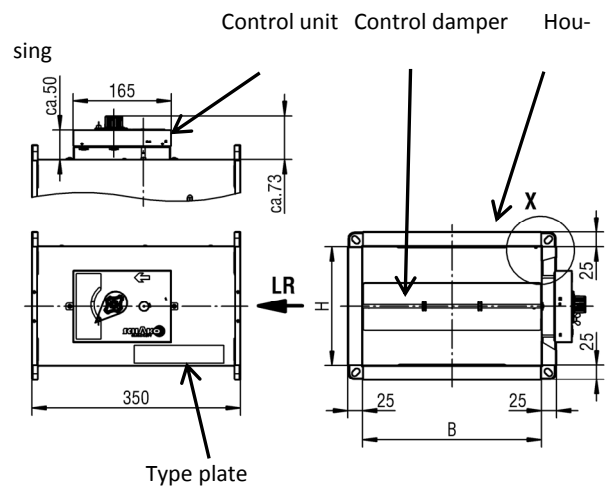

The VM-PRO-Q is delivered in right-hand design only. If the layout of the control unit is required on the left side, then the VM-PRO-Q must be rotated by 180°.

Legend

- x = available
- = not available
- LR = Air flow direction
- x^{1.)} = with two control units

Accessorieslist VM-PRO-R/-Q

Acoustic cladding (-DS)

made of sound-absorbing, insulating 20 mm material, non-flammable to DIN 4102-17, with sheet steel casing made of galvanised sheet steel (standard), stainless steel 1.4301 (V2A) or 1.4571 (V4A), with cage nuts (M6) (VM-PRO-Q only).

Flat-bed acoustic cladding (-FDS) - VM-PRO-R only

Made of sound-absorbing, insulating 3 mm material with sheet steel casing made of galvanised sheet steel (standard), stainless steel 1.4301 (V2A) or 1.4571 (V4A)

Flat flange (-FF) - VM-PRO-R only

on both sides, to DIN 24 154/5, made of the same material as the housing

Rubber lip seal (-GD) - VM-PRO-R only

on both sides, special rubber, silicone-free

METU flange (-MF) - VM-PRO-R only

on both sides, duct flange

Counter flange (-GF) - VM-PRO-R only

on both sides, to METU flange

Tension ring (-SR) - VM-PRO-R only

to connect METU flange to counter flange

Mineral wool silencer (-ZSQ) - VM-PRO-Q only

--- Housing made of galvanised sheet steel (standard), stainless steel 1.4301 (V2A) or 1.4571 (V4A)

--- Baffle frame made of galvanised sheet steel (standard), stainless steel 1.4301 (V2A) or 1.4571 (V4A), on both sides with METU profile M2

--- Mineral fibre boards according to DIN 4102 A2, with glass filament cover, biosoluble, wear-resistant

Duct silencer (-RS) - VM-PRO-R only

--- Rigid design

--- Outer casing and perforated plate made of galvanised sheet steel (standard), stainless steel 1.4301 (V2A) or 1.4571 (V4A).

--- Mineral wool filling

Construction subject to change

No return possible

Electric actuator (-E)

3-point control (standard)

--- VM-PRO-E-24

--- VM-PRO-E-230

Constant control

--- VM-PRO-E-24-SR

Corner angle - VM-PRO-Q only

As standard, the volumetric flow controller VM-PRO-Q is delivered with corner angle. The special form of the corner holes allows them to be connected to the connection systems available on the market (e.g. METU system M 2/M 3)

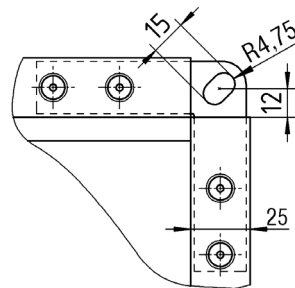

Dimensions of the accessories VM-PRO-R

Acoustic cladding (-DS, insulation = 20mm)

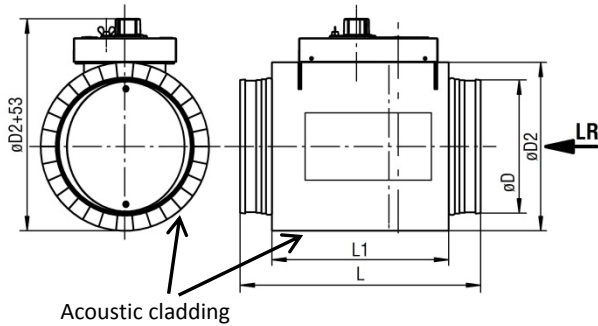

Acoustic cladding

Flat-bed acoustic cladding (-FDS)

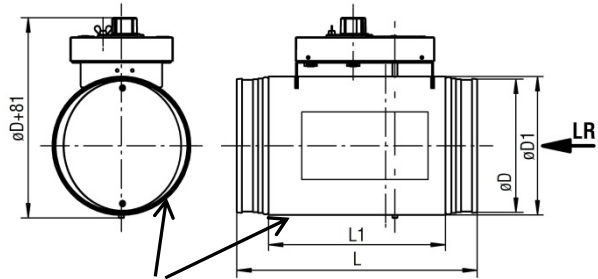

Flat-bed acoustic cladding

Available sizes (-FDS)

NW	$\varnothing D$	$\varnothing D1$	$\varnothing D2$	L	L1
80	78	84	120	290	205
100	98	104	140	290	205
125	123	129	165	290	205
160	158	164	200	290	205
200	198	204	240	290	205
250	248	254	290	390	230
315	313	319	355	390	260
400	398	404	440	490	360

Electric actuator (-E)

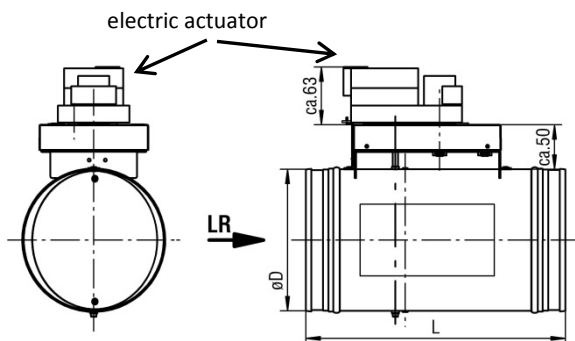

Construction subject to change
No return possible

Accessories flat flange (-FF)

on both sides - only VM-PRO-R - according to DIN 24 154/5

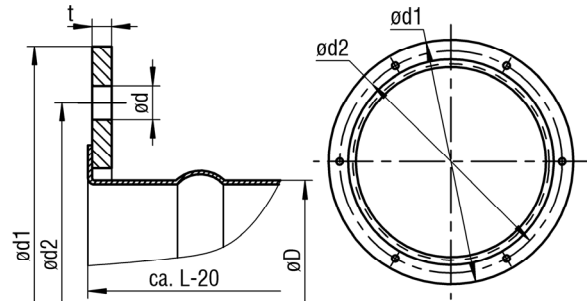

Available sizes flat flange (-FF)

NW	$\varnothing D$	L	$\varnothing d1$	$\varnothing d2$	$\varnothing d$	LOA	t
80	78	290	132	108	7	4	3
100	98	290	154	129	7	4	3
125	123	290	177	155	7	4	3
160	158	290	222	194	7	6	4
200	198	290	263	235	7	6	4
250	248	390	313	286	7	6	4
315	313	390	388	356	9.5	8	5
400	398	490	474	438	9.5	12	5

Accessories rubber lip seal (-GD)

VM-PRO-R only Detail X

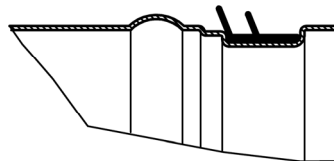

Accessories METU flange (-MF)

with counter flange (-GF) and tension ring (-SR)
on both sides (VM-PRO-R only)

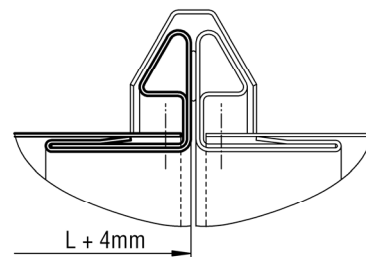

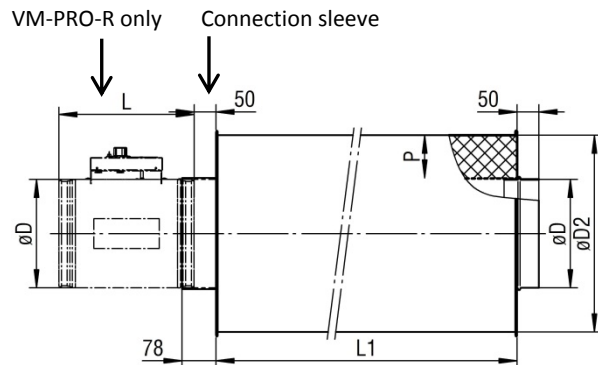
Duct silencer (-RS)

Packing thickness - duct silencer (-RS)

NW	L1=500 P (mm)		L1=950 P (mm)		L1=1450 P (mm)		L1=1950 P (mm)	
	50	100	50	100	50	100	50	100
80	x	x	x	x	-	-	-	-
100	x	x	x	x	x	-	x	-
125	x	x	x	x	x	-	x	-
160	x	x	x	x	x	x	-	x
200	x	x	x	x	x	x	-	x
250	x	x	x	x	x	x	-	x
315	x	x	x	x	x	x	-	-
400	x	x	x	x	x	x	-	-

x = available

- = not available

Available sizes - duct silencer (-RS)

NW	L	øD	øD2 P (mm)	
			50	100
80	290	78	180	280
100	290	98	200	300
125	290	123	225	325
160	290	158	260	360
200	290	198	300	400
250	390	248	350	450
315	390	313	415	515
400	490	398	500	600

Dimensions of the accessories VM-PRO-Q

with acoustic cladding (-DS, insulation 20 mm)

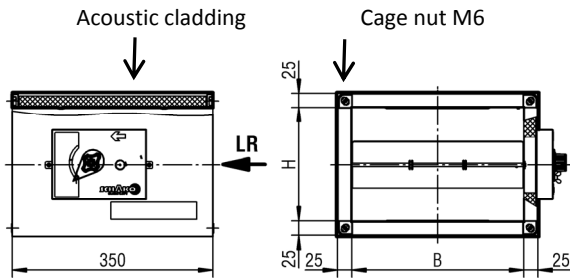

with electric actuator (-E)

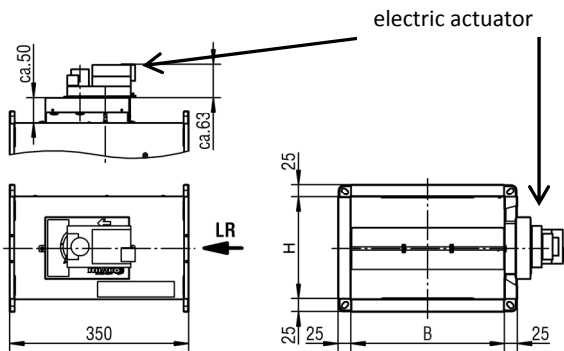

Available sizes -DS / -E

		Width B				
		200	300	400	500	600
Height H	100	x	x	-	-	-
	150	-	x	-	-	-
	200	-	x	x	x	x
	250	-	-	x	x	x
	300	-	-	x	x	x
	400	-	-	x ^{1.)}	x ^{1.)}	x ^{1.)}

Legend

- x = available
- = not available
- LR = Air flow direction
- x^{1.)} = with two control units

----->>>>----->>>>----->>>>

The parameters KA (number of baffles), K (baffle strength) and S (gap width) depend on the width B.

Construction subject to change
No return possible

Accessories mineral wool silencer (-ZSQ)

VM-PRO-Q only - with baffles type MW

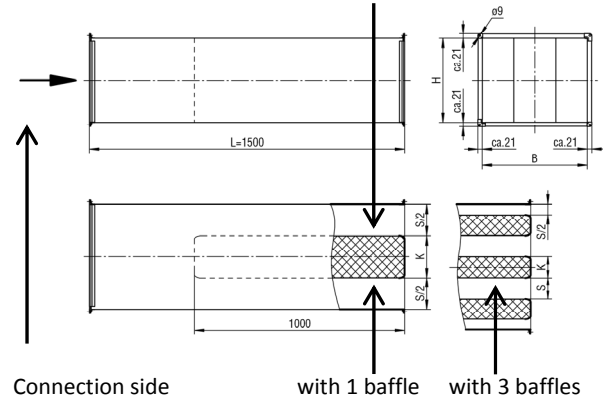

Insertion loss ZQS

B (mm)	D _e [dB/Okt] f _m (Hz)							
	63	125	250	500	1000	2000	4000	8000
200	1	3	9	18	36	37	22	13
300	1	2	4	8	15	14	9	6
400	1	4	11	19	25	20	11	7
500	1	4	7	8	15	15	8	5
600	1	3	9	18	36	37	22	13

Available sizes ZQS

H (mm)	B (mm)	KA (-)	K (mm)	S (mm)
100	200	1	100	100
100	300	1	100	200
150				
200	400	1	200	200
250				
300				
400				
200	500	1	200	300
250				
300				
200	600	3	100	100
250				
300				

Prior to assembly and commissioning



An instruction leaflet containing information on safety, transport disposal, installation, commissioning and maintenance is enclosed with each SCHAKO product. For safety reasons, this instruction leaflet must be read under all circumstances and completely adhered to.

MARKING

These devices are not suitable for use in non-approved Ex zones. The operating safety of the devices is only guaranteed when used in accordance with their designated use.

DISPOSAL

The devices have been prepared in accordance with the RoHS directive restricting the use of certain hazardous substances in electrical and electronic equipment (2002/95/EC). After its final decommissioning, the volumetric flow controller must be properly disposed of.

TESTS AND STANDARDS

The volumetric flow controller VM-PRO has been tested by the notified body in accordance with the following regulations:

Completed tests

- VDI 6022, Sheet 1: Hygienic requirements of ventilation and air-conditioning systems
- VDI 6022, Sheet 2: Hygienic requirements of ventilation and air-conditioning systems - Measurement methods and investigations during hygienic controls and hygienic inspections
- DIN 1946, Sheet 2: Air-conditioning technology - Health requirements
- DIN EN 13779 (2007): Ventilation of non-residential buildings

Applied standards

- Leakage air: EN 1751 (2011-02)
- EMV 2014/30/EU

Installation - maintenance - service

Required distances

To avoid unnecessary controller errors, the min. distances according to the following table / drawings must be observed. For combinations of several connection pieces or pieces with fire dampers or silencers, the larger minimum distances must be observed. All volumetric flow controllers can be assembled with horizontal or vertical damper axis.

Distance to	VM-PRO-R	VM-PRO-Q
Bent connection piece	1 x D	1 x diagonal
other connection pieces (e.g. T-junction, branching piece, reduction piece, etc.)	2 x D	2 x diagonal
Fire Damper	2 x D	2 x diagonal
Silencer	2 x D	2 x diagonal

Assembly

The controllers must be assembled in a way to allow inspection. The volumetric flow controllers are not suitable for air containing sticky and oily particles.

- When the device is delivered, check whether the controllers are complete and have been delivered without damage. Complaints have to be communicated immediately and directly to the transporter and SCHAKO.
- Volumetric flow controllers must not be carried on the regulation components or the damper leaf, but only on the housing.
- The controllers must be carefully stored on-site. They must be protected from dust, dirt and from direct weather effects.
- Assembly must be carried out by expert personnel, observing recognised technical rules and regulations.

Legend

ΔL_W	[dB/Okt]	=	Level correction value / octave
Δp	[Pa]	=	Pressure difference
$\Delta p_{st \min}$	[Pa]	=	Minimum static pressure difference
Δp_{st}	[Pa]	=	Pressure loss
Δp_W	[Pa]	=	Effective pressure
A	[m ³]	=	Inflow area (B x H)
B	[mm]	=	Width
D_e	[dB/Okt]	=	Insertion loss
EW_{Vmax}	[m ³ /h]	=	Set value of maximum air volume
f_m	[Hz]	=	Octave band centre frequency
H	[mm]	=	Height
K		=	Baffle thickness
KA	(-x-)	=	Number of baffles
KF	(-x-)	=	Correction factor
$L_W \text{ abst}$	[dB/Okt]	=	Radiated noise / octave
L_W	[dB/Okt]	=	Sound power level/octave ($L_W = L_{W1} + KF$)
L_{W1}	[dB/Okt]	=	Sound power level / octave, relative to 1 m ² of inflow area
L_{WA}	[dB(A)]	=	A-weighted sound power level ($L_{WA} = L_{WA1} + KF$)
NW	[mm]	=	Nominal width
S		=	Gap width
V	[m ³ /h/]	=	Air volume
V	[l/s]	=	Air volume
V_{ZU}	[m ³ /h]	=	Supply air volumetric flow
V_{max}	[m ³ /h]	=	Maximum air volume
V_{min}	[m ³ /h]	=	Minimum air volume
V_{Nenn}	[m ³ /h]	=	Nominal air volume
\dot{V}	[m ³ /h]	=	Volumetric flow
v_K	[m/s]	=	Duct velocity
$\varnothing D$	(-)	=	hydraulic diameter
ρ	[kg/m ³]	=	Density

CALCULATION FORMULAE

Calculation of the volumetric flow

$$\dot{V} = v_K \times F \times 3600$$

where : v_K (m/s) = duct velocity | F (m²) = area

Example for diameter 200 mm

$$v_K = 4 \text{ m/s}$$

$$F = 0.0314 \text{ m}^2$$

$$\dot{V} = v_K \times F \times 3600 = 4 \text{ m/s} \times 0.0314 \text{ m}^2 \times 3600$$

$$\dot{V} = 452 \text{ m}^3/\text{h}$$

VM-PRO - Minimum static pressure difference

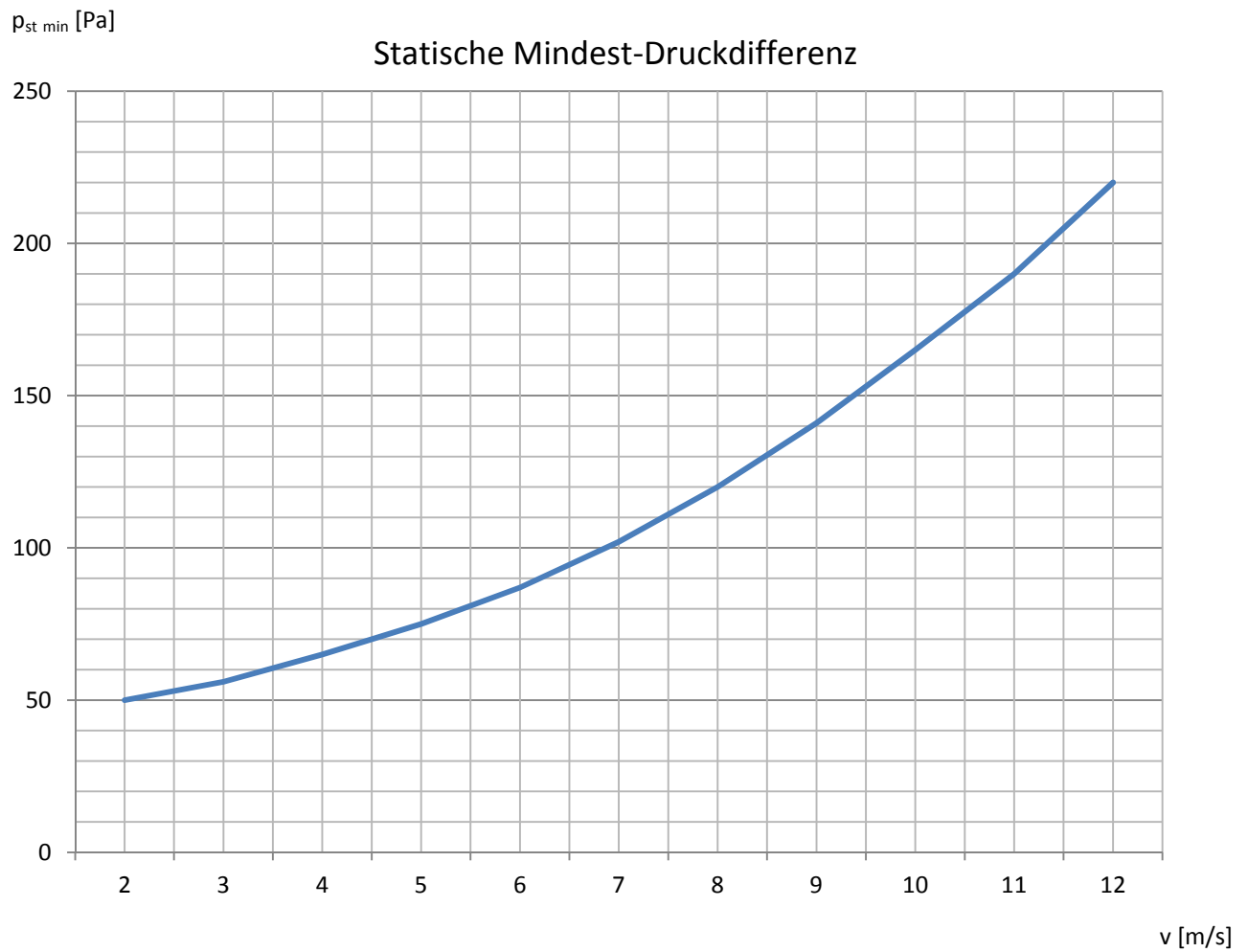

VM-PRO-R - Controller position

		\dot{V}	Nominal size NW							V*	
			80	100	125	160	200	250	315		400
Controller position	1	(m ³ /h)	50	70	120	180	250	300	450	700	2
		[l/s]	14	19	33	50	69	83	125	194	
	2	(m ³ /h)	75	80	160	280	325	400	600	1000	2.9
		[l/s]	21	22	44	78	90	111	167	278	
	3	(m ³ /h)	90	105	200	360	450	575	800	1600	3.8
		[l/s]	25	29	56	100	125	160	222	444	
	4	(m ³ /h)	105	130	240	420	575	750	1000	2000	4.7
		[l/s]	29	36	67	117	160	208	278	556	
	5	(m ³ /h)	120	160	275	480	700	900	1250	2500	5.6
		[l/s]	33	44	76	133	194	250	347	695	
	6	(m ³ /h)	130	185	310	540	825	1050	1500	2900	6.5
		[l/s]	36	51	86	150	229	292	417	806	
	7	(m ³ /h)	140	210	340	580	925	1175	1700	3300	7.3
		[l/s]	39	58	94	161	257	326	472	917	
	8	(m ³ /h)	150	225	370	625	1025	1300	1850	3600	8.2
		[l/s]	42	63	103	174	285	361	514	1000	
	9	(m ³ /h)	160	245	400	670	1100	1400	2000	4000	9.1
		[l/s]	44	68	111	186	306	389	556	1111	
	10	(m ³ /h)	170	260	420	700	1200	1500	2200	4200	10
		[l/s]	47	72	117	194	333	417	611	1167	

In controller positions 1 and 2, Δp must be >100 Pa.

* = Activation in volts for VM-PRO-R-E-SR

Circuit diagram controller

with electric actuator:

--- 3-point control (standard: VM-PRO-x-E-24; VM-PRO-x-E-230)

--- constant control (VM-PRO-x-E-24-SR)

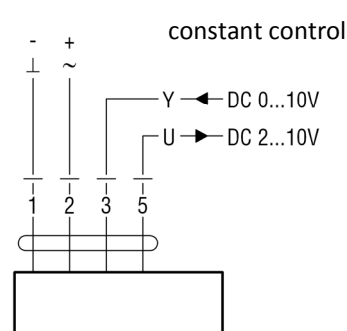
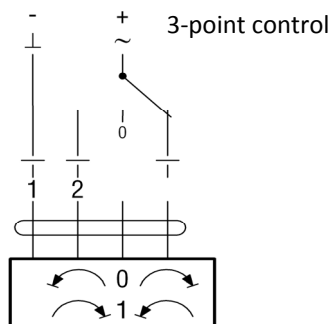

VM-PRO-R - flow generated noise

NW	RS	\dot{V}		$\Delta p_{st} = 100 \text{ Pa}$ $L_w \text{ (dB/Okt)}$ $f_m \text{ (Hz)}$							$L_{WA} \text{ [dB(A)]}$	$\Delta p_{st} = 250 \text{ Pa}$ $L_w \text{ (dB/Okt)}$ $f_m \text{ (Hz)}$							$L_{WA} \text{ [dB(A)]}$	$\Delta p_{st} = 500 \text{ Pa}$ $L_w \text{ (dB/Okt)}$ $f_m \text{ (Hz)}$							$L_{WA} \text{ [dB(A)]}$
		(m^3/h)	$[\text{l/s}]$	125	250	500	1000	2000	4000	125		250	500	1000	2000	4000	125	250		500	1000	2000	4000				
																								125	250	500	
80	3	90	25	42	42	42	41	41	41	47	48	48	46	47	47	47	53	52	52	51	51	51	51	57			
	6	130	36	45	45	45	44	44	44	50	51	51	50	50	50	50	56	55	55	54	54	54	54	60			
	10	170	47	49	49	49	48	48	48	54	54	54	54	53	53	53	59	59	59	58	58	58	58	64			
100	3	105	29	35	35	35	35	34	31	40	42	42	41	41	41	41	47	48	48	48	47	47	47	53			
	6	185	51	39	39	39	39	38	37	44	46	47	46	45	46	46	52	52	52	52	52	49	58				
	10	260	72	42	42	42	42	42	41	48	52	52	51	51	51	51	57	55	56	57	56	54	51	61			
125	3	200	55	37	38	37	36	36	31	41	45	47	47	46	44	42	51	51	51	51	51	51	50	57			
	6	310	86	43	43	43	41	41	39	47	50	51	51	50	49	47	55	56	56	56	56	56	54	62			
	10	420	117	47	48	48	47	46	45	53	55	55	54	54	54	52	60	61	61	61	60	60	58	66			
160	3	360	100	43	43	43	43	42	37	48	51	51	53	53	51	46	57	57	57	57	57	56	63				
	6	540	150	48	47	47	47	47	43	52	55	55	56	56	54	51	61	61	62	62	62	61	68				
	10	700	194	50	49	49	49	49	46	54	57	57	58	58	56	55	63	64	64	64	64	62	70				
200	3	450	125	42	42	42	42	41	36	47	50	50	50	49	48	42	54	56	56	55	55	55	52	61			
	6	825	229	49	48	48	49	48	43	54	56	56	55	55	55	50	60	61	61	61	60	60	58	66			
	10	1200	333	53	53	53	53	52	48	58	60	60	60	59	59	56	65	65	65	64	64	64	62	70			
250	3	575	160	42	41	41	41	36	28	44	50	51	51	51	48	40	55	58	58	58	57	56	50	62			
	6	1050	292	48	48	48	48	45	37	52	55	56	55	55	54	48	60	61	61	60	60	59	56	65			
	10	1500	417	52	52	52	52	51	43	56	59	59	58	58	58	53	63	63	63	63	62	62	60	68			
315	3	800	222	44	43	43	42	37	29	46	50	50	49	49	45	38	53	57	57	57	57	56	48	61			
	6	1500	417	49	49	49	48	43	35	52	56	56	55	55	53	44	59	62	62	62	62	62	54	67			
	10	2200	611	54	53	53	53	49	41	56	60	60	60	60	58	50	64	66	65	65	65	65	59	70			
400	3	1600	444	53	54	54	54	46	40	57	58	60	60	60	59	49	64	63	64	64	64	63	56	69			
	6	2900	806	56	57	57	57	49	44	60	61	63	63	63	62	52	67	67	68	67	67	68	60	72			
	10	4200	1167	60	61	60	60	55	48	63	65	67	67	67	66	56	71	70	71	70	70	70	63	75			

VM-PRO-R - Radiated noise

NW	RS	\dot{V}		$p_{st} = 100 \text{ Pa}$ $L_W \text{ (dB/Okt)}$ fm (Hz)						$L_{WA} \text{ [dB(A)]}$	$p_{st} = 250 \text{ Pa}$ $L_W \text{ (dB/Okt)}$ fm (Hz)						$L_{WA} \text{ [dB(A)]}$	$p_{st} = 500 \text{ Pa}$ $L_W \text{ (dB/Okt)}$ fm (Hz)						$L_{WA} \text{ [dB(A)]}$
		(m^3/h)	$[\text{l}/\text{s}]$	125	250	500	1000	2000	4000		125	250	500	1000	2000	4000		125	250	500	1000	2000	4000	
80	3	90	25	27	28	30	31	28	27	34	31	32	34	38	33	32	40	38	37	39	42	37	35	44
	6	130	36	29	31	33	34	30	29	37	33	35	38	41	36	35	43	42	40	43	45	40	37	47
	10	170	47	33	35	36	38	34	33	41	37	38	42	43	40	38	47	44	44	47	49	44	41	51
100	3	105	29	20	21	23	25	24	21	29	30	31	31	31	30	29	35	33	36	37	39	36	34	42
	6	185	51	23	22	24	28	26	24	31	34	36	36	35	35	33	40	37	39	41	43	38	36	46
	10	260	72	26	25	27	31	28	26	34	38	40	41	40	40	38	45	40	42	46	47	41	38	49
125	3	200	56	24	26	25	28	24	26	31	33	34	36	37	33	30	40	36	38	40	41	40	37	45
	6	310	86	29	30	31	32	29	26	35	38	39	40	41	38	34	44	41	43	45	46	44	42	50
	10	420	117	32	32	35	36	33	27	39	42	43	44	45	42	38	48	45	48	50	51	47	46	54
160	3	360	100	29	29	30	31	27	26	34	37	38	40	43	39	34	46	42	43	47	48	43	40	51
	6	540	150	33	33	34	35	31	30	38	41	43	44	47	42	38	49	46	47	52	53	48	43	56
	10	700	194	35	35	36	37	34	32	40	44	45	47	49	44	40	51	48	49	55	55	50	46	58
200	3	450	125	24	26	28	30	26	20	33	35	38	38	39	36	33	42	41	43	44	46	43	38	49
	6	825	229	31	33	34	35	33	27	39	41	43	45	45	42	40	48	46	47	50	51	48	43	54
	10	1200	333	35	38	38	40	37	32	43	45	48	49	50	46	44	53	50	51	53	54	51	48	57
250	3	575	160	25	26	27	27	24	22	31	35	37	39	41	34	34	43	43	45	47	47	45	37	51
	6	1050	292	30	31	33	34	32	30	38	41	42	43	46	41	39	48	46	48	51	50	48	38	54
	10	1500	417	33	35	37	39	38	35	43	45	45	47	49	46	43	52	48	51	52	54	51	39	57
315	3	800	222	23	25	31	32	28	22	35	36	36	39	39	36	33	42	42	44	46	49	41	38	51
	6	1500	417	31	35	37	38	31	25	40	41	42	44	46	43	35	49	47	49	51	53	47	41	55
	10	2200	611	39	43	41	43	35	29	45	44	46	49	51	47	37	54	51	53	54	55	52	45	59
400	3	1600	444	41	43	43	44	36	30	46	43	46	49	50	47	39	53	48	51	53	55	51	43	58
	6	2900	806	43	43	46	47	38	37	49	46	50	51	53	51	41	56	52	56	56	58	54	46	61
	10	4200	1167	49	48	49	50	45	39	53	50	54	55	57	55	45	60	55	58	59	60	57	50	63

VM-PRO-R - Radiated noise with acoustic cladding

NW	RS	\dot{V}		$p_{st} = 100 \text{ Pa}$ $L_w \text{ (dB/Okt)}$ fm (Hz)						$L_{WA} \text{ [dB(A)]}$	$p_{st} = 250 \text{ Pa}$ $L_w \text{ (dB/Okt)}$ fm (Hz)						$L_{WA} \text{ [dB(A)]}$	$p_{st} = 500 \text{ Pa}$ $L_w \text{ (dB/Okt)}$ fm (Hz)						$L_{WA} \text{ [dB(A)]}$
		(m^3/h)	$[\text{l/s}]$	125	250	500	1000	2000	4000		125	250	500	1000	2000	4000		125	250	500	1000	2000	4000	
80	3	90	25	22	25	27	25	19	15	29	26	29	31	32	24	20	34	33	34	36	36	28	23	39
	6	130	36	24	28	30	28	21	17	32	28	32	35	35	27	23	38	37	37	40	39	31	25	42
	10	170	47	28	32	33	32	25	21	35	32	35	39	37	31	26	41	39	41	44	43	35	29	46
100	3	105	29	15	18	20	19	15	15	23	25	28	28	25	21	17	30	28	33	34	33	27	22	36
	6	185	51	18	19	21	22	17	15	25	29	33	33	29	26	21	34	32	36	38	37	29	24	40
	10	260	72	21	22	24	25	19	15	28	33	37	38	34	31	26	39	35	39	43	41	32	26	44
125	3	200	56	19	23	22	22	15	15	25	28	31	33	31	24	18	35	31	35	37	35	31	25	39
	6	310	86	24	27	28	26	20	15	30	33	36	37	35	29	22	39	36	40	42	40	35	30	44
	10	420	117	27	29	32	30	24	15	34	37	40	41	39	33	26	43	40	45	47	45	38	34	49
160	3	360	100	24	26	27	25	18	15	29	32	35	37	37	30	22	40	37	40	44	42	34	28	45
	6	540	150	28	30	31	29	22	18	33	36	40	41	41	33	26	44	41	44	49	47	39	31	50
	10	700	194	30	32	33	31	25	20	35	39	42	44	43	35	28	46	43	46	52	49	41	34	53
200	3	450	125	19	23	25	24	17	15	27	30	35	35	33	27	21	37	36	40	41	40	34	26	43
	6	825	229	26	30	31	29	24	15	33	36	40	42	39	33	28	43	41	44	47	45	39	31	49
	10	1200	333	30	35	35	34	28	20	37	40	45	46	44	37	32	48	45	48	50	48	42	36	52
250	3	575	160	20	23	24	21	15	15	25	30	34	36	35	25	22	38	38	42	44	41	36	25	45
	6	1050	292	25	28	30	28	23	18	32	36	39	40	40	32	27	43	41	45	48	44	39	26	49
	10	1500	417	28	32	34	33	29	23	37	40	42	44	43	31	26	46	43	48	49	48	42	27	51
315	3	800	222	18	22	28	26	19	15	29	31	33	36	33	27	21	37	37	41	43	43	32	26	45
	6	1500	417	26	32	34	32	22	15	35	36	39	41	40	34	23	43	42	46	48	47	38	29	50
	10	2200	611	34	40	38	37	26	17	40	39	43	46	45	38	25	48	46	50	51	49	43	33	53
400	3	1600	444	36	40	40	38	27	18	41	38	43	46	44	38	27	48	43	48	50	49	42	31	52
	6	2900	806	38	40	43	41	29	25	44	41	47	48	47	42	29	50	47	53	53	52	45	34	55
	10	4200	1167	44	45	46	44	36	27	47	45	51	52	51	46	33	54	50	55	56	54	48	38	58

VM-PRO-R - duct silencer (-RS) - insertion loss

		D _e (dB/Okt)																
		P=50 f _m (Hz)								P=100 f _m (Hz)								
		63	125	250	500	1000	2000	4000	8000	63	125	250	500	1000	2000	4000	8000	
L1=500	NW	80	4	7	12	18	26	33	17	15	6	16	18	23	39	36	33	20
		100	3	6	10	16	22	30	14	13	5	13	15	19	33	31	25	15
		125	3	5	9	14	20	24	12	11	4	10	13	18	29	25	18	12
		160	2	4	7	12	18	19	10	9	3	9	11	16	26	19	14	10
		200	1	3	6	10	16	15	7	6	3	7	9	15	25	17	11	9
		250	1	2	4	9	15	11	4	3	2	6	8	14	23	15	9	7
		315	1	1	3	8	12	8	3	2	2	4	7	13	20	12	7	5
		400	1	1	3	7	10	7	2	1	1	3	6	12	18	9	4	4
L1=950	NW	80	5	14	27	42	50	50	40	24	9	22	30	45	50	50	50	39
		100	5	12	23	36	50	50	34	21	7	19	28	40	50	50	50	32
		125	4	11	21	33	50	50	32	19	6	17	25	34	49	50	36	22
		160	3	8	15	23	34	29	18	14	5	12	18	28	41	48	26	16
		200	2	5	11	18	30	24	14	11	4	10	15	24	35	41	22	13
		250	2	4	9	15	27	18	11	9	3	8	13	20	31	35	20	11
		315	1	3	6	12	24	14	7	6	2	6	8	15	26	27	14	8
		400	1	2	4	10	19	10	4	4	2	4	6	11	23	20	10	6
L1=1450	NW	80	8	22	44	50	50	50	46	28	-	-	-	-	-	-	-	-
		100	8	22	44	50	50	50	46	28	-	-	-	-	-	-	-	-
		125	7	20	39	50	50	50	39	25	-	-	-	-	-	-	-	-
		160	6	14	27	42	48	42	26	18	6	17	30	47	50	49	30	18
		200	4	6	15	29	42	30	17	14	5	14	26	42	50	46	28	16
		250	3	4	10	20	37	24	13	11	4	12	22	36	46	43	25	14
		315	2	4	8	16	34	19	10	7	2	8	15	27	35	32	17	9
		400	1	2	6	15	27	13	8	5	2	6	12	23	30	25	13	7
L1=1950	NW	80	9	30	50	50	50	50	50	38	-	-	-	-	-	-	-	-
		100	9	30	50	50	50	50	50	38	-	-	-	-	-	-	-	-
		125	8	26	50	50	50	50	50	33	-	-	-	-	-	-	-	-
		160	-	-	-	-	-	-	-	-	8	23	39	50	50	50	41	25
		200	-	-	-	-	-	-	-	-	7	19	34	50	50	50	37	21
		250	-	-	-	-	-	-	-	-	6	16	29	48	50	49	33	18
		315	-	-	-	-	-	-	-	-	-	-	-	-	-	-	-	-
		400	-	-	-	-	-	-	-	-	-	-	-	-	-	-	-	-

VM-PRO-Q - Controller position

	\dot{V}	Nominal size NW (BxH)								V*
		200x100	300x100	300x150	300x200	400x200	400x250	400x300	400x400	
1	(m ³ /h)	200	325	250	225	500	850	700	900	2
	[l/s]	56	90	69	63	139	236	194	250	
2	(m ³ /h)	275	425	375	450	700	1100	1100	1400	2.9
	[l/s]	76	118	104	125	194	306	306	389	
3	(m ³ /h)	375	500	525	700	900	1450	1500	1800	3.8
	[l/s]	104	139	146	194	250	403	417	500	
4	(m ³ /h)	475	600	675	900	1100	1800	1850	2300	4.7
	[l/s]	132	167	188	250	306	500	514	639	
5	(m ³ /h)	550	700	850	1050	1300	2100	2200	2700	5.6
	[l/s]	153	194	236	292	361	583	611	750	
6	(m ³ /h)	600	775	1000	1250	1450	2400	2500	3100	6.5
	[l/s]	167	215	278	347	403	667	694	861	
7	(m ³ /h)	650	850	1150	1400	1600	2700	2800	3400	7.3
	[l/s]	181	236	319	389	444	750	778	944	
8	(m ³ /h)	700	925	1275	1500	1750	2900	3100	3800	8.2
	[l/s]	194	257	354	417	486	806	861	1056	
9	(m ³ /h)	750	1000	1400	1650	1900	3100	3400	4200	9.1
	[l/s]	208	278	389	458	528	861	944	1167	
10	(m ³ /h)	800	1075	1500	1800	2050	3200	3600	4400	10
	[l/s]	222	299	417	500	569	889	1000	1222	

In controller positions 1 and 2, Δp must be >100 Pa.

* = Activation in volts for VM-PRO-Q-E-SR

Circuit diagram controller

with electric actuator:

--- 3-point control (standard: VM-PRO-x-E-24; VM-PRO-x-E-230)

--- constant control (VM-PRO-x-E-24-SR)

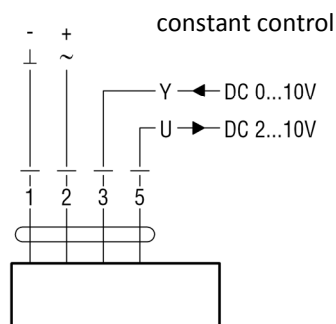
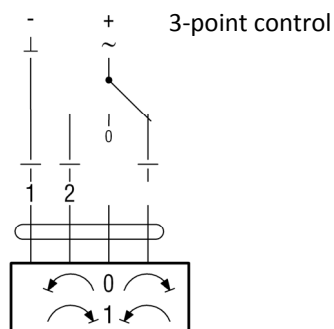

VM-PRO-Q - controller position (continued)

	\dot{V}	Nominal size NW (BxH)								V*	
		500x200	500x250	500x300	500x400	600x200	600x250	600x300	600x400		
Controller position	1	(m ³ /h)	650	950	1200	1300	450	1200	1700	1900	2
		[l/s]	181	264	333	361	125	333	472	528	
	2	(m ³ /h)	1000	1300	1650	2000	1000	1500	2100	2500	2.9
		[l/s]	278	361	458	556	278	417	583	694	
	3	(m ³ /h)	1300	1600	2100	2600	1450	1950	2600	3400	3.8
		[l/s]	361	444	583	722	403	542	722	944	
	4	(m ³ /h)	1600	2100	2600	3200	1950	2350	3200	4300	4.7
		[l/s]	444	583	722	889	542	653	889	1194	
	5	(m ³ /h)	1950	2500	3050	3900	2400	2800	3700	5000	5.6
		[l/s]	542	694	847	1083	667	778	1028	1389	
	6	(m ³ /h)	2200	2850	3500	4400	2800	3200	4150	5800	6.5
		[l/s]	611	792	972	1222	778	889	1153	1611	
	7	(m ³ /h)	2450	3200	3850	4900	3200	3600	4600	6400	7.3
		[l/s]	681	889	1069	1361	889	1000	1278	1778	
	8	(m ³ /h)	2650	3550	4200	5300	3500	3950	5000	7000	8.2
		[l/s]	736	986	1167	1472	972	1097	1389	1944	
	9	(m ³ /h)	2900	3900	4550	5800	3800	4300	5400	7600	9.1
		[l/s]	806	1083	1264	1611	1056	1194	1500	2111	
	10	(m ³ /h)	3100	4200	4800	6200	4100	4600	5800	8200	10
		[l/s]	861	1167	1333	1722	1139	1278	1611	2278	

In controller positions 1 and 2, Δp must be >100 Pa.

* = Activation in volts for VM-PRO-Q-E-SR

VM-PRO-Q - flow generated noise

(200x100 to 400x400)

BxH	RS	\dot{V}		$\Delta p_{st} = 100 \text{ Pa}$ $L_w \text{ (dB/Okt)}$ $f_m \text{ (Hz)}$						$L_{WA} \text{ [dB(A)]}$	$\Delta p_{st} = 250 \text{ Pa}$ $L_w \text{ (dB/Okt)}$ $f_m \text{ (Hz)}$						$L_{WA} \text{ [dB(A)]}$	$\Delta p_{st} = 500 \text{ Pa}$ $L_w \text{ (dB/Okt)}$ $f_m \text{ (Hz)}$						$L_{WA} \text{ [dB(A)]}$
		(m^3/h)	$[\text{l}/\text{s}]$	125	250	500	1000	2000	4000		125	250	500	1000	2000	4000		125	250	500	1000	2000	4000	
200 x 100	3	375	104	44	44	43	43	43	42	49	51	51	51	51	50	50	57	57	57	56	56	56	56	62
	6	600	167	50	50	49	49	49	49	55	57	57	56	56	56	56	62	62	62	61	61	61	61	67
	10	800	222	53	53	52	52	52	52	58	60	60	59	59	60	59	66	65	65	64	64	64	64	70
300 x 100	3	500	139	45	45	43	43	43	42	49	52	51	51	51	51	51	57	58	58	57	57	57	57	63
	6	775	215	50	50	49	49	49	49	55	57	56	56	56	56	56	62	62	62	61	61	61	61	67
	10	1075	299	53	53	53	53	53	52	59	60	60	60	60	60	60	66	66	65	65	65	65	65	71
300 x 150	3	525	146	42	42	42	41	41	35	46	50	49	49	49	49	46	54	57	57	57	56	56	56	62
	6	1000	278	50	50	50	49	49	46	55	56	56	56	56	55	62	62	62	61	61	61	61	61	67
	10	1500	417	54	54	54	54	53	52	59	61	61	61	61	61	60	67	66	66	66	66	65	65	72
300 x 200	3	700	194	43	43	43	43	40	33	46	52	51	51	51	51	45	56	57	58	58	56	56	55	62
	6	1250	347	50	50	50	49	50	44	55	57	57	56	56	56	53	62	63	62	62	61	62	61	68
	10	1800	500	54	54	54	54	54	49	59	62	61	61	61	61	59	67	67	66	66	66	66	65	72
400 x 200	3	900	250	46	46	45	45	41	33	49	51	50	53	53	51	42	57	56	57	59	60	56	49	63
	6	1450	403	51	50	53	52	48	39	56	53	56	58	59	57	48	62	60	62	63	62	60	54	66
	10	2950	569	56	56	55	56	55	47	59	56	55	61	62	58	54	65	63	65	65	66	63	61	69
400 x 250	3	1450	403	48	48	48	47	44	37	51	56	54	54	54	54	46	59	61	61	61	61	60	56	66
	6	2400	667	54	54	54	53	53	45	58	61	60	60	60	60	54	65	66	66	65	65	65	62	71
	10	3200	889	57	57	57	56	56	49	61	64	64	64	64	63	60	69	69	69	69	69	68	66	74
400 x 300	3	1500	417	47	47	47	46	41	33	50	55	54	54	54	51	44	58	61	61	61	61	60	53	66
	6	2500	694	53	54	53	53	50	42	57	61	60	60	60	59	52	65	66	66	66	66	65	59	71
	10	3600	1000	58	57	57	57	55	47	61	65	64	64	64	64	58	69	70	70	69	69	69	64	74
400 x 400	3	1800	500	47	47	47	45	37	30	49	55	55	55	54	48	40	57	62	62	61	61	58	50	65
	6	3100	861	53	53	53	52	46	38	55	61	60	60	60	55	46	63	67	67	65	65	64	56	70
	10	4400	1222	58	58	57	56	52	44	60	65	64	64	64	61	53	68	70	70	69	69	68	61	74

VM-PRO-Q - Flow generated noise continued

(500x200 to 600x400)

BxH	RS	\dot{V}		$\Delta p_{st} = 100 \text{ Pa}$ $L_w \text{ (dB/Okt)}$ $f_m \text{ (Hz)}$						$L_{WA} \text{ [dB(A)]}$	$\Delta p_{st} = 250 \text{ Pa}$ $L_w \text{ (dB/Okt)}$ $f_m \text{ (Hz)}$						$L_{WA} \text{ [dB(A)]}$	$\Delta p_{st} = 500 \text{ Pa}$ $L_w \text{ (dB/Okt)}$ $f_m \text{ (Hz)}$						$L_{WA} \text{ [dB(A)]}$
		(m^3/h)	$[\text{l}/\text{s}]$	125	250	500	1000	2000	4000		125	250	500	1000	2000	4000		125	250	500	1000	2000	4000	
500 x 200	3	1300	36	47	47	46	46	45	37	51	54	54	54	54	53	48	59	61	60	60	60	60	57	65
	6	2200	611	53	53	53	52	52	47	57	60	59	59	59	59	56	64	66	65	64	64	65	63	70
	10	3100	861	57	57	57	57	56	52	62	61	64	64	64	64	61	69	69	69	68	68	68	68	74
500 x 250	3	1600	444	48	48	47	47	43	35	51	55	55	55	55	54	46	60	62	62	61	61	61	56	66
	6	2850	792	55	55	54	54	53	46	59	61	61	61	61	60	55	66	66	66	66	66	66	62	71
	10	4200	1167	59	58	58	58	58	51	63	66	66	66	65	65	62	71	71	71	70	70	70	68	76
500 x 300	3	2100	583	47	47	46	46	39	31	49	54	54	54	54	51	43	58	62	62	61	61	61	53	66
	6	3500	972	52	52	52	52	48	40	55	59	59	58	58	57	49	63	65	65	65	65	65	57	70
	10	4800	1333	57	57	57	57	54	46	61	63	63	63	63	63	56	68	68	68	68	68	68	63	73
500 x 400	3	2600	722	50	50	50	48	40	32	52	57	57	57	56	51	43	60	64	64	63	63	60	52	67
	6	4400	1222	56	56	56	56	50	42	59	63	63	62	62	59	51	66	68	68	68	67	66	59	72
	10	6200	1722	60	59	59	59	54	46	62	67	66	66	66	64	57	70	72	71	71	71	71	64	76
600 x 200	3	1450	403	47	47	46	46	44	37	50	55	55	54	54	54	47	59	61	61	61	61	60	58	66
	6	2800	778	54	54	54	54	54	48	59	61	61	61	60	60	57	66	66	66	66	66	65	65	72
	10	4100	1139	58	58	58	57	57	52	62	65	65	65	64	64	62	71	70	70	70	69	69	69	76
600 x 250	3	1950	542	48	48	48	48	44	37	52	56	56	55	55	54	47	60	62	62	62	62	61	57	67
	6	3200	889	54	54	54	54	53	46	59	61	61	60	60	60	55	65	66	66	66	66	65	63	71
	10	4600	1278	59	58	58	58	58	51	63	66	66	65	65	65	61	70	71	71	70	70	70	68	76
600 x 300	3	2600	722	51	51	51	50	45	37	54	59	58	57	58	56	47	62	63	63	63	63	62	56	68
	6	4150	1153	56	56	56	56	53	46	60	63	63	63	62	62	54	67	68	68	68	68	67	62	73
	10	5800	1611	60	59	59	59	58	50	63	67	67	67	66	66	60	71	72	72	71	71	71	67	76
600 x 400	3	3400	944	51	51	51	49	43	35	53	58	58	58	58	52	44	61	65	65	65	64	62	54	68
	6	5800	1611	58	58	58	57	52	44	61	65	64	64	64	61	53	68	71	70	70	70	68	60	74
	10	8200	2278	62	62	62	62	57	49	65	70	69	69	69	67	60	73	75	74	74	74	74	66	79

VM-PRO-Q - Radiated noise

(200x100 to 400x400)

BxH	RS	\dot{V}		p _{st} = 100 Pa L _w (dB/Okt) fm (Hz)						L _{WA} [dB(A)]	p _{st} = 250 Pa L _w (dB/Okt) fm (Hz)						L _{WA} [dB(A)]	p _{st} = 500 Pa L _w (dB/Okt) fm (Hz)						L _{WA} [dB(A)]
		(m ³ /h)	[l/s]	125	250	500	1000	2000	4000		125	250	500	1000	2000	4000		125	250	500	1000	2000	4000	
200 x 100	3	375	104	27	29	32	32	31	26	37	35	37	40	40	39	34	45	42	44	46	46	46	41	51
	6	600	167	32	35	37	37	36	30	42	40	43	45	45	44	38	50	46	49	51	51	50	44	56
	10	800	222	35	40	41	40	39	34	45	43	48	49	48	47	42	53	50	55	56	54	54	49	60
300 x 100	3	500	139	29	32	34	34	33	28	39	37	40	42	42	41	36	47	43	46	48	48	47	42	53
	6	775	215	33	36	38	38	37	31	43	42	45	47	47	46	40	52	47	50	52	52	51	45	57
	10	1075	299	37	42	43	41	41	36	47	45	50	51	50	49	44	55	51	56	57	55	55	50	61
300 x 150	3	525	146	29	31	33	33	33	28	38	34	36	39	38	38	33	43	42	44	47	46	46	41	51
	6	1000	278	33	36	38	38	37	31	43	40	43	45	45	44	38	50	46	49	51	51	50	44	56
	10	1500	417	37	42	43	41	41	36	47	45	50	51	49	49	44	55	50	55	56	54	54	49	60
300 x 200	3	700	194	29	31	33	33	33	27	38	34	36	39	39	38	33	44	42	44	47	47	46	41	52
	6	1250	347	33	37	38	38	37	31	43	40	43	45	44	44	38	49	46	50	52	51	50	45	56
	10	1800	500	37	42	43	41	41	36	47	45	50	51	49	49	44	55	51	56	57	55	55	50	61
400 x 200	3	900	250	30	33	34	35	33	26	38	35	38	45	45	42	34	47	41	45	48	50	45	37	53
	6	1450	403	37	38	43	44	40	34	46	36	41	48	49	45	36	52	44	50	52	53	49	42	56
	10	2950	569	42	44	45	46	45	39	49	41	44	49	52	48	42	55	48	52	55	56	53	48	59
400 x 250	3	1450	403	32	34	36	36	36	30	41	38	42	44	43	42	37	48	45	50	51	49	49	44	55
	6	2400	667	38	41	43	43	42	36	48	44	49	50	48	48	43	54	50	55	56	54	54	49	60
	10	3200	889	40	45	46	44	44	40	50	48	53	54	52	52	47	58	54	59	60	58	58	53	64
400 x 300	3	1500	417	30	32	35	34	34	30	39	37	40	42	42	41	35	47	45	48	50	50	49	43	55
	6	2500	694	36	38	41	40	40	36	45	43	48	49	48	47	42	53	49	54	55	54	53	48	59
	10	3600	1000	41	43	46	45	45	41	50	48	53	54	52	52	46	57	53	58	59	57	57	52	63
400 x 400	3	1800	500	29	31	34	33	33	29	38	36	39	41	41	40	34	46	44	49	50	48	48	43	54
	6	3100	861	35	37	40	39	39	35	44	42	46	47	46	45	40	51	49	54	55	53	53	48	59
	10	4400	1222	40	42	45	44	44	40	49	47	52	53	51	51	46	57	53	58	59	57	57	52	63

VM-PRO-Q - Radiated noise continued

(500x200 to 600x400)

BxH	RS	\dot{V}		$p_{st} = 100 \text{ Pa}$ $L_w \text{ (dB/Okt)}$ $f_m \text{ (Hz)}$						$L_{WA} \text{ [dB(A)]}$	$p_{st} = 250 \text{ Pa}$ $L_w \text{ (dB/Okt)}$ $f_m \text{ (Hz)}$						$L_{WA} \text{ [dB(A)]}$	$p_{st} = 500 \text{ Pa}$ $L_w \text{ (dB/Okt)}$ $f_m \text{ (Hz)}$						$L_{WA} \text{ [dB(A)]}$
		$\text{(m}^3/\text{h)}$	[l/s]	125	250	500	1000	2000	4000		125	250	500	1000	2000	4000		125	250	500	1000	2000	4000	
500 x 200	3	1300	36	31	33	36	35	35	31	40	39	41	44	43	43	39	48	45	50	51	49	49	44	55
	6	2200	611	37	39	42	41	41	35	46	44	49	50	48	44	54	54	55	55	53	53	48	59	
	10	3100	861	41	44	46	46	45	38	50	49	54	55	53	53	47	58	53	58	59	57	57	52	63
500 x 250	3	1600	444	31	33	36	35	35	31	40	39	42	44	43	43	37	48	45	50	51	49	49	44	55
	6	2850	792	39	41	44	43	43	39	48	45	50	51	49	49	44	55	50	55	56	54	54	49	60
	10	4200	1167	43	45	48	47	47	43	52	50	55	56	54	54	49	60	54	59	60	58	58	53	64
500 x 300	3	2100	583	30	32	35	34	34	29	39	38	40	43	42	42	36	47	45	50	51	49	49	44	55
	6	3500	972	35	38	40	40	39	33	45	43	45	48	47	43	52	52	48	53	54	52	52	47	58
	10	4800	1333	40	43	45	45	44	40	50	48	52	53	51	52	47	57	52	57	58	56	56	51	62
500 x 400	3	2600	722	32	34	37	36	36	32	41	38	42	44	43	42	37	48	46	51	52	50	50	45	56
	6	4400	1222	39	41	44	43	43	39	48	45	50	51	49	49	44	55	50	55	56	54	54	49	60
	10	6200	1722	41	44	46	46	45	39	51	50	55	56	54	54	49	60	55	60	61	59	59	54	65
600 x 200	3	1450	403	30	33	35	35	34	30	40	38	41	43	43	42	37	48	46	51	52	50	50	45	56
	6	2800	778	38	41	43	43	42	37	48	45	48	50	49	49	44	54	51	57	57	55	55	50	61
	10	4100	1139	42	44	47	46	46	42	54	49	54	55	53	53	48	62	54	59	60	58	58	53	66
600 x 250	3	1950	542	33	35	37	36	36	32	41	39	43	45	43	40	49	49	46	51	52	50	50	45	56
	6	3200	889	39	41	44	43	43	39	48	44	49	50	48	46	54	54	50	55	56	54	54	49	60
	10	4600	1278	43	45	48	47	47	43	52	49	54	55	53	53	48	59	55	60	61	59	59	54	65
600 x 300	3	2600	722	35	37	40	39	39	35	44	41	45	47	45	39	50	48	52	54	52	52	48	58	
	6	4150	1153	40	42	45	44	44	40	49	46	51	52	50	45	56	52	57	58	56	57	51	62	
	10	5800	1611	44	46	49	48	48	44	53	50	55	56	54	49	60	55	60	61	59	59	54	65	
600 x 400	3	3400	944	32	35	37	37	36	31	42	41	45	46	45	39	50	48	53	54	52	52	47	58	
	6	5800	1611	39	42	44	44	43	38	49	47	52	53	52	46	57	47	52	53	52	51	46	57	
	10	8200	2278	45	47	50	49	49	45	56	53	59	60	58	52	65	58	63	64	62	62	57	69	

VM-PRO-Q - Radiated noise with acoustic cladding

(200x100 to 400x400)

BxH	RS	\dot{V}		$p_{st} = 100 \text{ Pa}$ $L_w \text{ (dB/Okt)}$ fm (Hz)						$L_{wVA} \text{ [dB(A)]}$	$p_{st} = 250 \text{ Pa}$ $L_w \text{ (dB/Okt)}$ fm (Hz)						$L_{wVA} \text{ [dB(A)]}$	$p_{st} = 500 \text{ Pa}$ $L_w \text{ (dB/Okt)}$ fm (Hz)						$L_{wVA} \text{ [dB(A)]}$
		(m^3/h)	$[\text{l/s}]$	125	250	500	1000	2000	4000		125	250	500	1000	2000	4000		125	250	500	1000	2000	4000	
200 x 100	3	375	104	22	26	29	26	22	15	30	30	34	37	34	30	22	38	37	41	43	40	37	29	45
	6	600	167	27	32	34	31	27	18	35	35	40	42	39	35	26	43	41	46	48	45	41	32	49
	10	800	222	30	37	38	34	30	22	39	38	45	46	42	38	30	47	45	52	53	48	45	37	54
300 x 100	3	500	139	24	29	31	28	24	16	32	32	37	39	36	32	24	40	38	43	45	42	38	30	46
	6	775	215	28	33	35	32	28	19	36	37	42	44	41	37	28	45	42	47	49	46	42	33	50
	10	1075	299	32	39	40	35	32	24	41	40	47	48	44	40	32	49	46	53	54	49	46	38	55
300 x 150	3	525	146	24	28	30	27	24	16	32	29	33	36	32	29	21	37	37	41	44	40	37	29	45
	6	1000	278	28	33	35	32	28	19	36	35	40	42	39	35	26	43	41	46	48	45	41	32	49
	10	1500	417	32	39	40	35	32	24	41	40	47	48	43	40	32	49	45	52	53	48	45	37	54
300 x 200	3	700	194	24	28	30	27	24	15	32	29	33	36	33	29	21	37	37	41	44	41	37	29	45
	6	1250	347	28	34	35	32	28	19	36	35	40	42	38	35	26	43	41	47	49	45	41	33	50
	10	1800	500	32	39	40	35	32	24	41	40	47	48	43	40	32	49	46	53	54	49	46	38	55
400 x 200	3	900	250	25	29	31	29	27	24	34	30	33	38	38	32	24	41	36	40	43	45	41	36	48
	6	1450	403	32	36	38	37	31	25	40	33	39	43	43	39	27	46	39	42	46	47	45	32	51
	10	2950	569	36	38	38	40	37	28	43	38	38	45	46	41	40	49	43	46	50	51	48	39	54
400 x 250	3	1450	403	27	31	33	30	27	18	35	33	39	41	37	33	25	42	40	47	48	43	40	32	49
	6	2400	667	33	38	40	37	33	24	41	39	46	47	42	39	31	48	45	52	53	48	45	37	54
	10	3200	889	35	42	43	38	35	28	44	43	50	51	46	43	35	52	49	56	57	52	49	41	58
400 x 300	3	1500	417	25	29	32	28	25	18	33	32	37	39	36	32	23	40	40	45	47	44	40	31	48
	6	2500	694	31	35	38	34	31	24	39	38	45	46	42	38	30	47	44	51	52	48	44	36	53
	10	3600	1000	36	40	43	39	36	29	44	43	50	51	46	43	34	52	48	55	56	51	48	40	57
400 x 400	3	1800	500	24	28	31	27	24	17	32	31	36	38	35	31	22	39	39	46	47	42	39	31	48
	6	3100	861	30	34	37	33	30	23	38	37	43	44	40	36	28	45	44	51	52	47	44	36	53
	10	4400	1222	35	39	42	38	35	28	43	42	49	50	45	42	34	51	48	55	56	51	48	40	57

VM-PRO-Q - Radiated noise with acoustic cladding continued

(500x200 to 600x400)

BxH	RS	\dot{V}		$p_{st} = 100 \text{ Pa}$ $L_w \text{ (dB/Okt)}$ $f_m \text{ (Hz)}$						$L_{WA} \text{ [dB(A)]}$	$p_{st} = 250 \text{ Pa}$ $L_w \text{ (dB/Okt)}$ $f_m \text{ (Hz)}$						$L_{WA} \text{ [dB(A)]}$	$p_{st} = 500 \text{ Pa}$ $L_w \text{ (dB/Okt)}$ $f_m \text{ (Hz)}$						$L_{WA} \text{ [dB(A)]}$
		(m^3/h)	$[\text{l}/\text{s}]$	125	250	500	1000	2000	4000		125	250	500	1000	2000	4000		125	250	500	1000	2000	4000	
500 x 200	3	1300	36	26	30	33	29	26	19	34	34	38	41	37	34	27	42	40	47	48	43	40	32	49
	6	2200	611	32	36	39	35	32	23	40	39	46	47	42	39	32	48	44	52	52	47	44	36	53
	10	3100	861	36	41	43	40	36	26	44	44	51	52	47	44	35	53	48	55	56	51	48	40	57
500 x 250	3	1600	444	26	30	33	29	26	19	34	34	39	41	37	34	25	42	40	47	48	43	40	32	49
	6	2850	792	34	38	41	37	34	27	42	40	47	48	43	40	32	49	45	52	53	48	45	37	54
	10	4200	1167	38	42	45	41	38	31	46	45	52	53	48	45	37	54	49	56	57	52	49	41	58
500 x 300	3	2100	583	25	29	32	28	25	17	33	33	37	40	36	33	24	41	40	47	48	43	40	32	49
	6	3500	972	30	35	37	34	30	21	38	38	42	45	41	38	31	46	43	50	51	46	43	35	52
	10	4800	1333	35	40	42	39	35	28	43	43	49	50	45	35	51	47	54	55	50	47	39	56	
500 x 400	3	2600	722	27	31	34	30	27	20	35	33	39	41	37	33	25	42	41	48	49	44	41	33	50
	6	4400	1222	34	38	41	37	34	27	42	40	47	48	43	40	32	49	45	52	53	48	45	37	54
	10	6200	1722	36	41	43	40	36	27	44	45	52	53	48	45	37	54	50	57	58	53	50	42	59
600 x 200	3	1450	403	25	30	32	29	25	18	33	33	38	40	37	33	25	41	41	48	49	44	41	33	50
	6	2800	778	33	38	40	37	33	25	41	40	45	47	43	40	32	48	46	54	54	49	46	38	55
	10	4100	1139	37	40	44	40	37	29	45	44	51	52	47	44	36	54	49	56	57	52	49	41	59
600 x 250	3	1950	542	28	32	34	30	27	20	35	34	40	42	37	34	28	43	41	48	49	44	41	33	50
	6	3200	889	34	38	41	37	34	27	42	39	46	47	42	39	34	48	45	52	53	48	45	37	54
	10	4600	1278	38	42	45	41	38	31	46	44	51	52	47	44	36	53	50	57	58	53	50	42	59
600 x 300	3	2600	722	30	34	37	33	30	23	38	36	42	44	39	36	27	45	43	49	51	46	43	36	52
	6	4150	1153	35	39	42	38	35	28	43	41	48	49	44	41	33	50	47	54	55	50	48	39	56
	10	5800	1611	39	43	46	42	39	32	47	45	52	53	48	45	37	54	50	57	58	53	50	42	59
600 x 400	3	3400	944	27	32	34	31	27	19	35	36	42	43	39	36	27	44	43	50	51	46	43	35	52
	6	5800	1611	34	39	41	38	34	26	42	42	49	50	46	42	34	51	48	56	57	51	48	41	57
	10	8200	2278	39	43	46	42	38	32	48	47	54	55	50	47	39	57	52	59	60	55	52	44	62

VM-PRO-Q - mineral wool silencer (-ZSQ) - insertion loss

VM-PRO-Q only - with baffles type MWK

B (mm)	D _e [dB/Okt] f _m (Hz)							
	63	125	250	500	1000	2000	4000	8000
200	1	3	9	18	36	37	22	13
300	1	2	4	8	15	14	9	6
400	1	4	11	19	25	20	11	7
500	1	4	7	8	15	15	8	5
600	1	3	9	18	36	37	22	13

Specification text VM-PRO-R

Round model

Mechanical volumetric flow controller type VM-PRO-R, in round design, right-hand model, for constant volumetric flow regulation up to a max. differential pressure of 1000 Pa, for duct connection to DIN EN 1506. Housing and control damper made of galvanised sheet steel, control housing made of plastic.

Product: SCHAKO type VM-PRO-R

Size.....

Housing and control damper (at an extra charge) made of:

- Galvanised sheet steel with DD coating (-DD)
- Stainless steel 1.4301 (-V2A)
- Stainless steel 1.4571 (-V4A)

Control housing (at an extra charge) made of:

- Stainless steel 1.4301 (-V2A)
- Stainless steel 1.4571 (-V4A)

Accessories (at an extra charge)

- Acoustic cladding (-DS) made of 20 mm sound-absorbing material, non-flammable to DIN 4102-17, with sheet metal casing.
- Flat-bed acoustic cladding (-FDS), made of 3 mm sound-absorbing material with sheet metal casing.
- METU flange (-MF), on both sides, duct flange AF.
- Counter flange (-GF), on both sides, to METU flange.
- Tension ring (-SR) to connect METU flange to counter flange.
- Flat flange (-FF), on both sides, to DIN 24 154 / 5, made of the same material as the housing.
- Rubber lip seal (-GD) on both sides, made of special rubber, silicone-free.
- Duct silencer (-RS), outer casing and perforated plate made of galvanised sheet steel, at an extra charge made of stainless steel 1.4301 (V2A) or 1.4571 (V4A), with mineral wool filling.
- Electric actuator (-E), 3-point control (standard, VM-PRO-E-24, VM-PRO-E-230) or constant control (VM-PRO-E-24-SR), for adjusting the supply air and return air volume to varying room occupations.

Specification text VM-PRO-Q

Rectangular model

Mechanical volumetric flow controller type VM-PRO-Q, in rectangular design, right-hand model, for constant volumetric flow regulation up to a max. differential pressure of 1000 Pa, for duct connection to DIN 1505. Housing and control damper made of galvanised sheet steel, control housing made of plastic.

Product: SCHAKO type VM-PRO-Q

Size.....

Housing and control damper (at an extra charge) made of:

- Galvanised sheet steel with DD coating (-DD)
- Stainless steel 1.4301 (-V2A)
- Stainless steel 1.4571 (-V4A)

Control housing (at an extra charge) made of:

- Stainless steel 1.4301 (-V2A)
- Stainless steel 1.4571 (-V4A)

Accessories (at an extra charge)

- Acoustic cladding (-DS) made of 20 mm sound-absorbing material, non-flammable to DIN 4102-17, with sheet metal casing and including M6 cage nuts.
- Mineral wool silencer (-ZSQ) on both sides with METU profile M2, housing (L=1500) made of galvanised sheet steel, at an extra charge made of stainless steel 1.4301 (V2A) or 1.4571 (V4A), with integrated MWK silencing baffles (L=1000). The MWK silencing baffles with RAL quality seal consist of abrasion-resistant mineral fibre boards covered with fibre glass filament (biosoluble, non-flammable to DIN 4102) in a frame made of the same material as the mineral wool silencer housing. Baffles measured to ISO/DIS 7235 and to DIN 45646.
- Electric actuator (-E), 3-point control (standard, VM-PRO-E-24, VM-PRO-E-230) or constant control (VM-PRO-E-24-SR), for adjusting the supply air and return air volume to varying room occupations.

Order details / order code

Mechanical volumetric flow controller VM-PRO type			
Round design (-R...) for duct connection to DIN EN 1506 fits position-independent		Rectangular design (-Q...x...) for duct connection to DIN EN 1505 Right-hand design	
constant volumetric flow V_{konst}			
Housing made of stainless steel 1.4301 (-V2A)	Housing made of stainless steel 1.4571 (-V4A)	Galvanised sheet steel housing	Housing made of galvanised steel with DD coating (-DD)
Control housing made of stainless steel 1.4301 (-V2A)	Control housing made of stainless steel 1.4571 (-V4A)	Control housing made of plastic	
Electric actuator (-E...)			
Electric actuator with 3-point control (standard)			
--- for 24 V AC/DC (-E-24)			
--- for 230 V AC (-E-230)			
--- variable volumetric flow $V_{min} - V_{max}$ from to			
electric actuator with continuous control			
--- for 24 V AC/DC continuous 0-10 V DC (-E-24-SR)			
--- variable volumetric flow $V_{min} - V_{max}$ from to			
Accessories			
--- Acoustic cladding (-DS), - insulation 20 mm			
--- Flat-bed acoustic cladding (-FDS) - insulation 3 mm - VM-PRO-R-... only			
--- Flat flange (-FF) - VM-PRO-R-... only			
--- Counter flange (-GF) - VM-PRO-R-... only			
--- Rubber lip seal (-GD) - VM-PRO-R-... only			
--- METU flange (-MF) - VM-PRO-R-... only			
--- Mineral wool silencer with MWK sound-absorbing baffle (-ZSQ) - VM-PRO-Q... only			
--- Duct silencer (-RS) - VM-PRO-R-... only			
--- Tension ring (-SR) - VM-PRO-R-... only			

Unless stated otherwise, the specification in grey will be delivered

Order example

VM-PRO-R160-E-230-DS-GD

VM-PRO - Mechanical volumetric flow controller

- R160 = round design with diameter 160 mm
- E-230 = with electric actuator for alternating voltage of 230 Volt
- DS = with acoustic cladding (standard=20 mm)
- GD = with rubber lip seal