

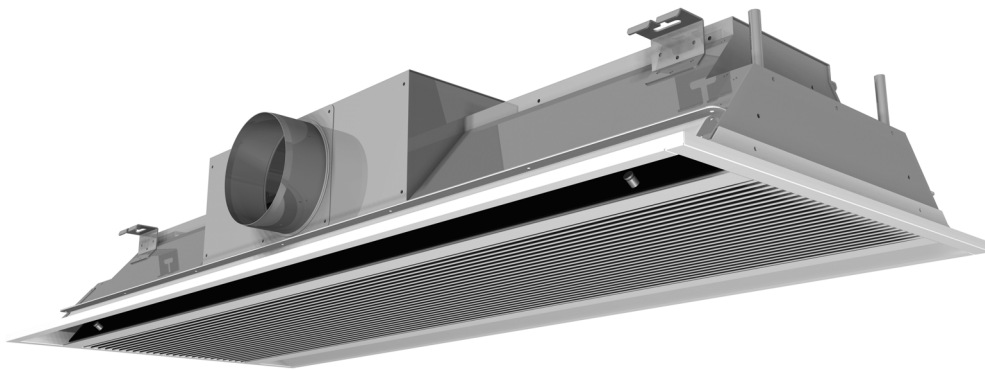

Ceiling induction diffuser

DISA-601



Ferdinand Schad KG
Steigstraße 25-27
D-78600 Kolbingen
Phone +49 (0) 74 63 - 980 - 0
Fax +49 (0) 74 63 - 980 - 200
info@schako.de
www.schako.de

Ceiling induction diffuser DISA-601

Contents

Description	3
Advantages	3
Function	3
Description of the equipment	4
Construction	4
Fastening	4
Model	4
Accessories	4
Models and dimensions	5
Dimensions and weights	5
Accessories	7
Figures	8
System solution	8
Technical data	9
Performance data	9
Sound level	25
Flow data	26
Control units	34
Valves	34
Actuators	35
Control units	36
Condensation detector	38
Assembly	39
Maintenance	39
Legend	39
Ordering details	40
Specification text	41

Ceiling induction diffuser DISA-601

Description

Ceiling induction diffusers combine the flow characteristics of air diffusers with the energetic advantages of load discharge via water-based heat exchangers, allowing them to remove high thermal loads from the room while keeping the hygienically required air exchange low. The construction of the ceiling induction diffuser DISA-601 is very maintenance- and mounting-friendly and is also suitable for low false ceiling heights, due to its small height. Its 4 different nozzle configurations B, C, D, E and lengths of up to 3.0 metres allow the ceiling induction diffuser DISA-601 to be precisely adapted to all room requirements.

Advantages

- High energy efficiency
- High performance (compensation of high thermal loads)
- Compact dimensions and low height
- Saving in energy by means of reduced primary air
- Low noise level
- low mounting and maintenance expenditure

Function

The primary air (1) supplied from the plenum box induces secondary air in the room (2), which is cooled or heated via the register (4).

The primary air is mixed with the cooled secondary air. The mixed (3) primary and secondary air flows are supplied to the room at low velocity via 2 supply air slots.

Schematic diagram of the mode of operation

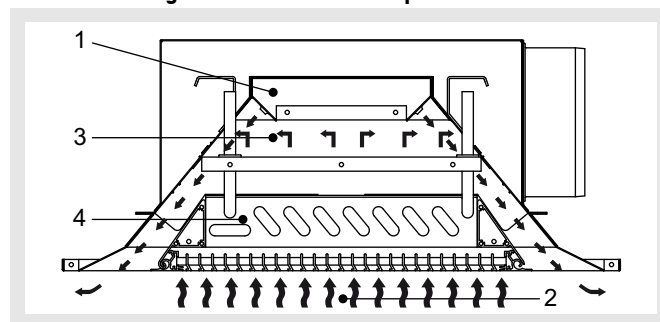

- 1 Primary air
- 2 Room air
- 3 Secondary air
- 4 Heat exchanger

Schematic diagram of the jet path

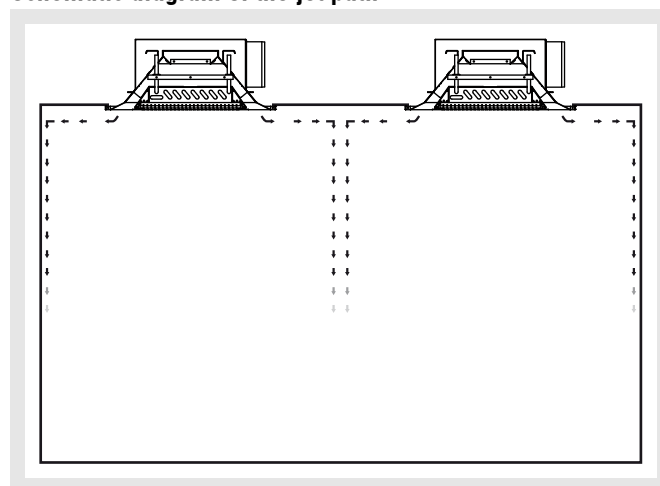

Ceiling induction diffuser DISA-601

Description of the equipment

Construction

Housing

- Galvanised sheet steel with 1 or 2 primary air connection pieces $\varnothing 98$, $\varnothing 123$ (standard) and $\varnothing 148$ mm. Return air connection piece optional.
- Connecting piece position for primary and return air:
 - horizontal (-H)
 - vertical (-V)
- Arrangement of the primary air connecting pieces:
 - 1 horizontal connection piece in the middle (-AS1, standard) or (-AS4)
 - 2 horizontal connection pieces (-AS2/AS3) or (-AS5/-AS6)
 - 1 vertical connection piece in the middle (-AS7)
 - 2 vertical connection pieces (-AS8/-AS9)
- Return air connection piece arrangement:
 - 1 horizontal connection piece (-HL or -HR), at the front or at the back (-1 or -2)
 - 1 vertical connection piece (-VR or -VL)

Slot

- Sheet steel profile painted to RAL 9010 (white, standard)

Perforated sheet grille (-SR/-SQ/-RE/-OB)

- Perforated sheet grille galvanised sheet steel painted to RAL 9010 (white, standard) with different perforated sheet grille designs

Louvre grid (-PA)

- Extruded aluminium profile painted to RAL 9010 (white, standard)

Heat exchanger

- 2-pipe system (cooling or heating) or optionally 4-pipe system (cooling and heating)
 - Galvanised sheet steel frame
 - Aluminium blades
 - Copper pipes $\varnothing 12$ mm
 - Connection Cu, d=12 x 1.0 smooth
 - painted RAL 9005 (black, optional)

Fastening

Fixing brackets

- for easy suspension of the induction diffuser

Model

- DISA-601-H - 2-pipe system (standard)
- DISA-601-HT - 4-pipe system
- DISA-601-BO - without register
- DISA-...-LE - With individually adjustable air deflection
- DISA-...-LB - Blockwise adjustable air deflection blades
- DISA-...-SR - Foldable perforated sheet, perforation $\varnothing 6$ mm (standard)
- DISA-...-SQ - Foldable perforated sheet, perforation 8x8 mm
- DISA-...-RE - Foldable perforated sheet, perforation 12x5
- DISA-...-OB - Foldable perforated sheet, oval perforation 20x6 mm
- DISA-...-PA - Foldable louvre grid type PA
- DISA-...-B - Nozzle configuration B (Technical data p.9-10 + 17-18 + 26-27)
- DISA-...-C - Nozzle configuration C (Technical data p.11-12 + 19-20 + 28-29)
- DISA-...-D - Nozzle configuration D (Technical data p.13-14 + 21-22 + 30-31)
- DISA-...-E - Nozzle configuration E (Technical data p.15-16 + 23-24 + 32-33)
- DISA-...-592 - Total width 592 mm
- DISA-...-597 - Total width 597 mm
- DISA-...-617 - Total width 617 mm
- DISA-...-622 - Total width 622 mm
- DISA-...-FM - Total width 900 mm
- DISA-...-900 - nominal length 900 mm
- DISA-...-1200 - nominal length 1200 mm
- DISA-...-1500 - nominal length 1500 mm
- DISA-...-1800 - nominal length 1800 mm
- DISA-...-2100 - nominal length 2100 mm
- DISA-...-2400 - nominal length 2400 mm
- DISA-...-2700 - nominal length 2700 mm
- DISA-...-3000 - nominal length 3000 mm
- DISA-...-2E - Model with two end pieces (standard)
- DISA-...-EL - Model with left-hand end piece
- DISA-...-ER - Model with right-hand end piece
- DISA-...-OE - Model without end pieces
- DISA-...-A - with return air connection piece
- DISA-...-BA - Accessories for band design

Accessories

Rubber lip seal (-GD)

Flexible connection hoses

- 500 mm (-FA 500)
- 800 mm (-FA 800)
- 1200 mm (-FA 1200)

External thread flat sealing (-WA 1/2)

Volumetric flow measuring tube

Control units

- Valves
- Actuators
- Room temperature control
- Condensation detector

Ceiling induction diffuser DISA-601

Models and dimensions

Dimensions and weights

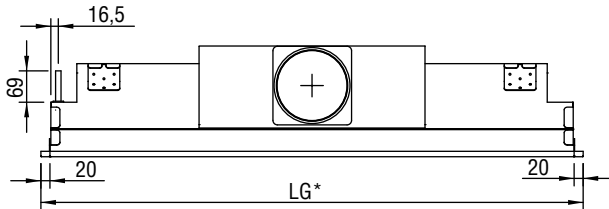

LG* (mm) = total length of the device with and without end pieces
 B (mm) = 592 / 597 / 617 / 622 / 900(-FM)
 ØD (mm) = diameter of the connection pieces (98, 123 and 148)

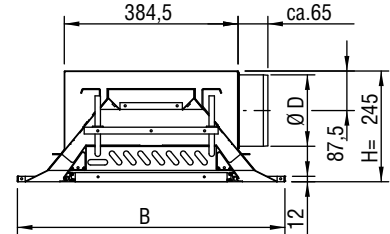

with perforated sheet grille (-SR/-SQ/-RE/-OB)



with louvre grid (-PA)

Arrangement of the connection pieces (-AS) and water connection (-WS)

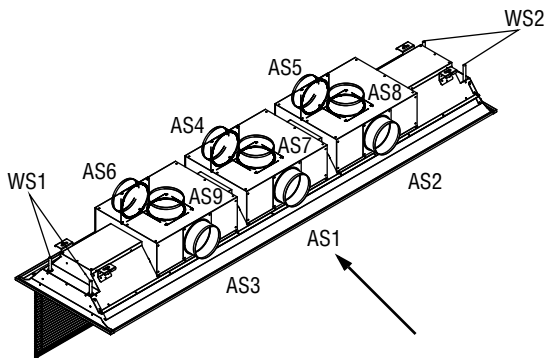

Number/position of the connection pieces

- with horizontal connection (-H)
 - with 1 central connection piece (-AS1) or (-AS4)
 - with 2 connection pieces (-AS2/AS3) or (-AS5/AS6)
- with vertical connection (-V)
 - with 1 central connection piece (-AS7)
 - with 2 connection pieces (-AS8/AS9)

Number/position of the water connections

- with 2 water connections (2-pipe system, standard)
- with 4 water connections (4-pipe system)
- sideways top left (-WS1)
- sideways top right (-WS2)

Horizontal connection (-H)

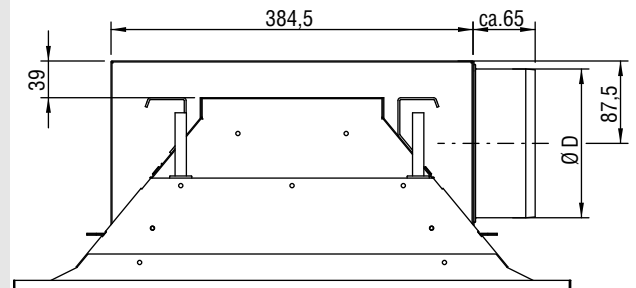

Vertical connection (-V)

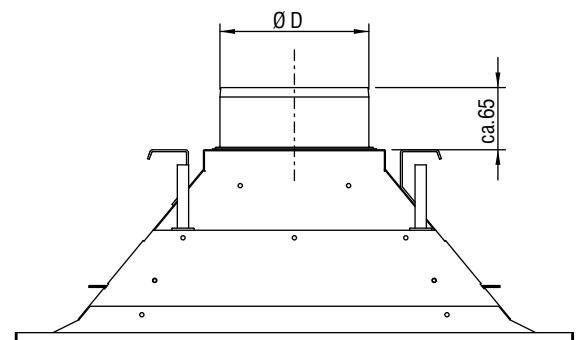

Weights DISA-601

NL	900	1200	1500	1800	2100	2400	2700	3000
Weights ⁽¹⁾ (kg)	23	28	34	39	45	51	56	62

⁽¹⁾ Standard unit: housing + slot + grille and heat exchanger (empty)

Ceiling induction diffuser DISA-601

Number of connection pieces

Horizontal connection (-H)

with 1 connection piece (-AS1) (-AS4)

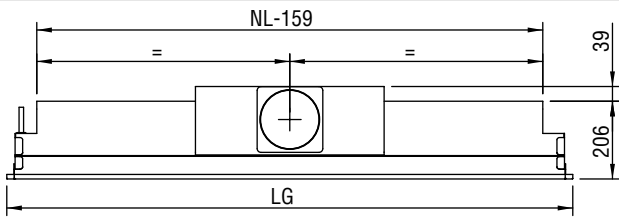

with 2 connection pieces (-AS2/AS3) (-AS5/AS6)

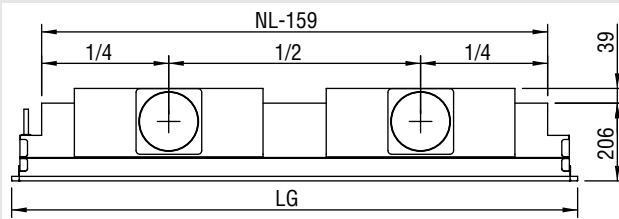

Vertical connection (-V)

with 1 connection piece (-AS7)

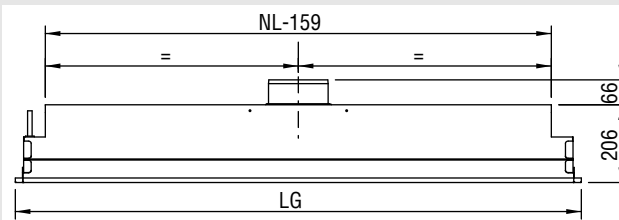

with 2 connection pieces (-AS8/AS9)

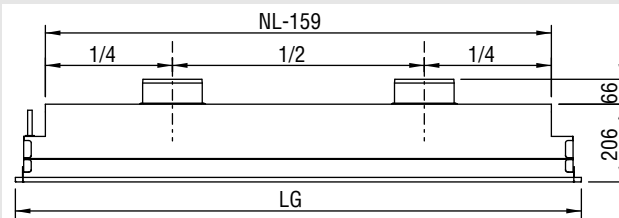

Hydraulic connections

DISA-601-H (2-pipe)

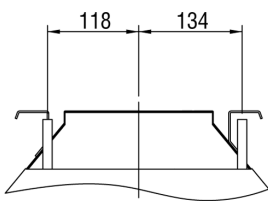

DISA-601-HT (4-pipe)

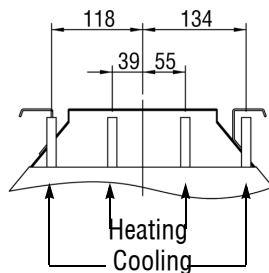

Return air connection pipe arrangement (-A)

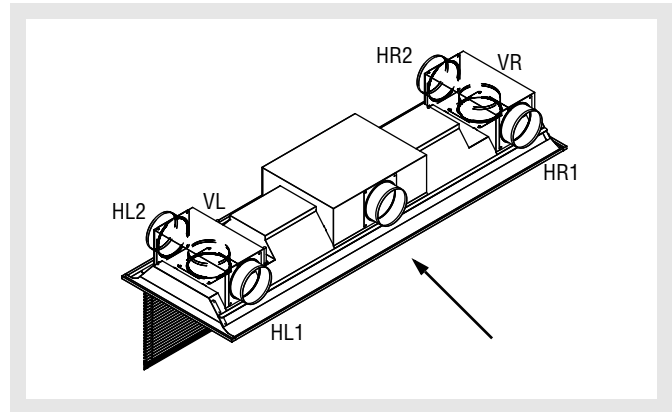

Number/position of the return air connection pieces

- with horizontal connection (-H)
 - Right front (R1) or right back (R2)
 - Left front (L1) or left back (L2)
- with vertical connection (-V)
 - Right (R)
 - Left (L)

Housing position

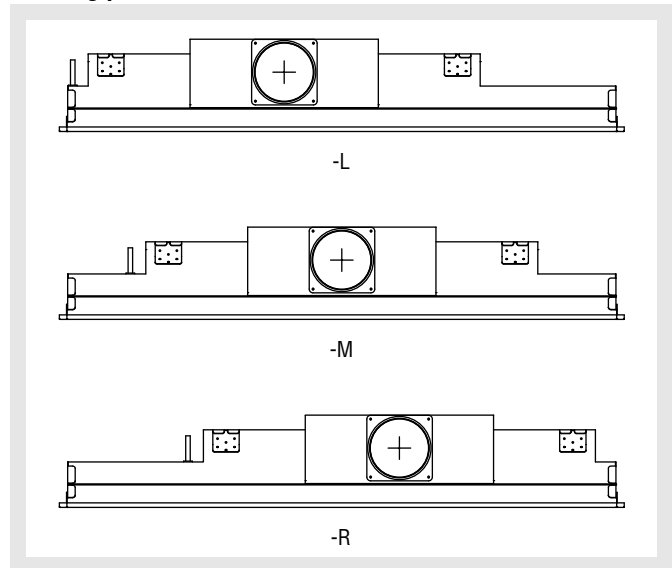

Perforated sheet grille design

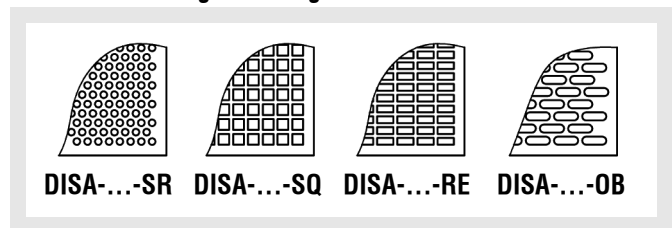

Ceiling induction diffuser DISA-601

Fixing brackets

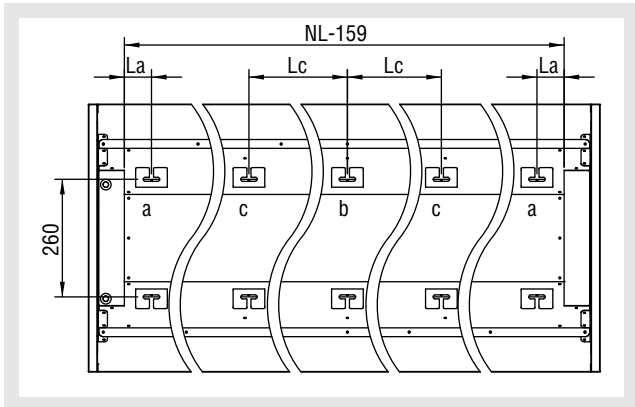

NL	La (mm)	Lc (mm)	H		V
			1	2	
900	35	-	a	a	a
1200		-	a	a	a
1500		-	a	a	a
1800		-	a	a	a
2100		350	a,c	a,b	a,b
2400			a,c	a,b	a,b
2700			a,c	a,b	a,b
3000			a,c	a,b	a,b

Air deflection blades

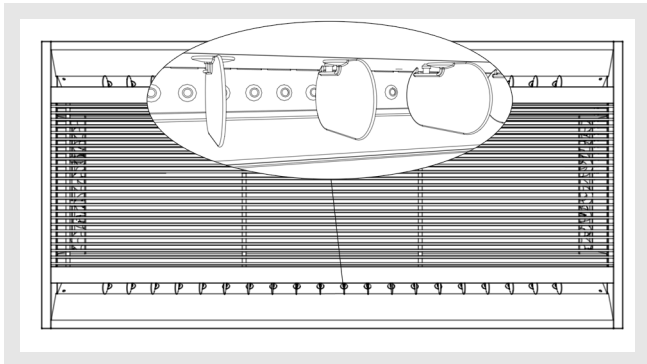

- Individually adjustable air deflection blades (-LE)
- Blockwise adjustable air deflection blades (-LB)

With blockwise adjustable blades, 5 blades can be adjusted simultaneously.



The adjusting angle of the air deflection blades must not be more than $\pm 45^\circ$, in order to guarantee its function.



At an adjusting angle of the air deflection blades outside the straight air throw of up to 45° , the cooling capacity of the heat exchanger is reduced by up to 5%, and the horizontal throw is reduced.

Accessories

Band design (-BA)

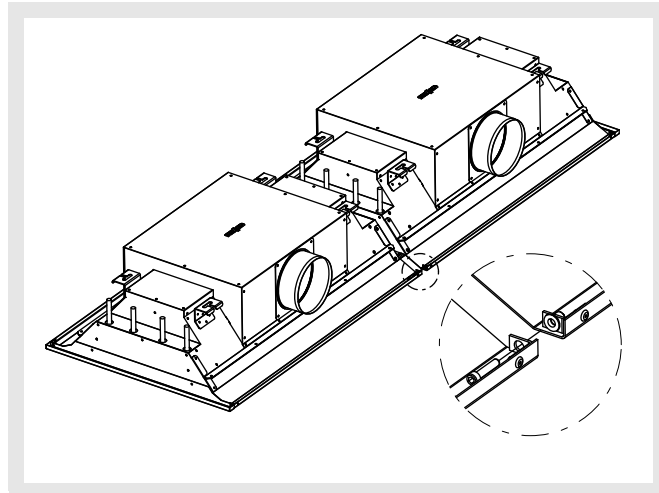

Rubber lip seal (-GD)

At the connecting piece for better tightness.

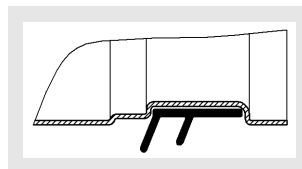

Volumetric flow measuring tube (-MR)

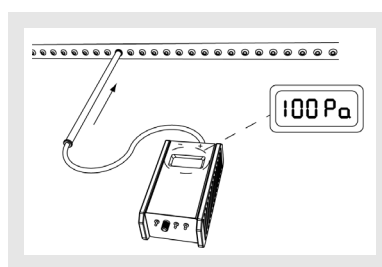

The supplied primary volumetric flow can be simply checked by checking the static pressure with a Pa meter.

Flexible connection hoses (-FA)

Flexible armoured hose with stainless steel braid, resistant to oxygen diffusion to DIN 4726, one-sided by means of plug-in fitting 90° with stainless steel claw, support ring, 2 sealing rings (operating pressure 20 bar, test pressure 60 bar, temperature -40° to $+80^\circ$) and lock washer, other side $1/2"$ spigot nut with flat seal.

L = 500, 800 and 1200 mm. Other lengths on request.

External thread flat-sealing



Water connections $1/2"$ external thread flat-sealing

Ceiling induction diffuser DISA-601

Figures

DISA-601 with end piece (-2E, standard)

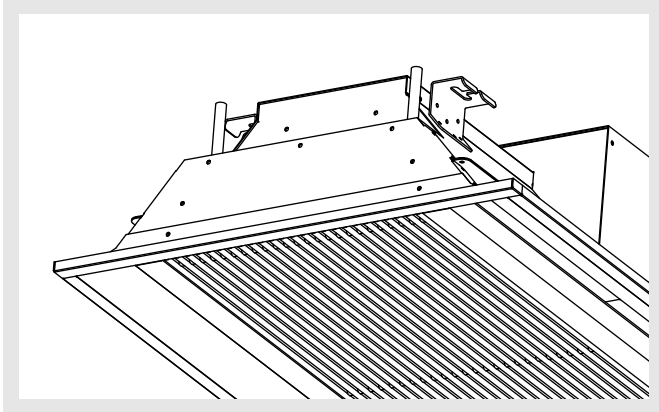

View from below

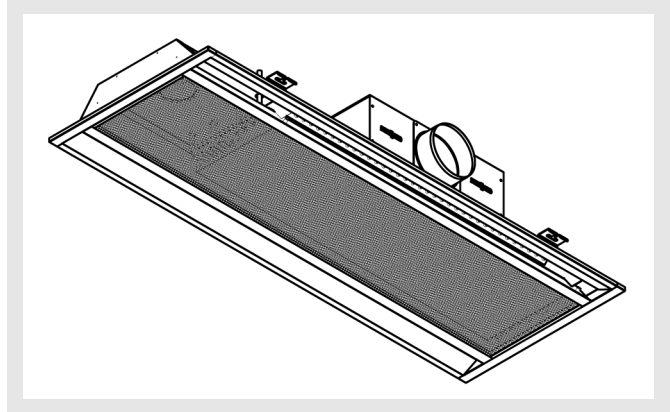

DISA-601 without end piece (-0E)

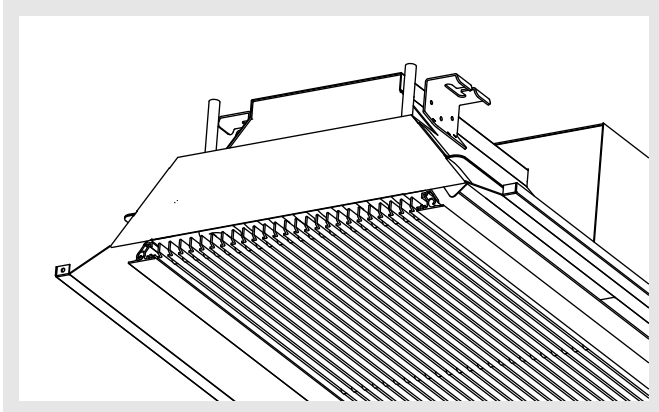

System solution

SCHAKO offers system solutions that can be integrated perfectly into the room architecture.

Example of a system solution with lighting and sprinkler

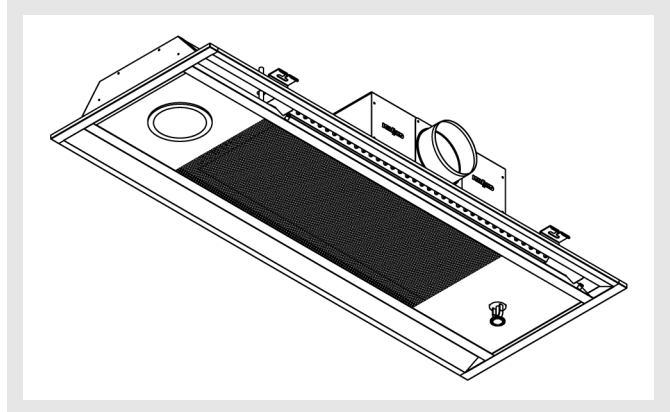

DISA-601 band design without end pieces mounted in-between

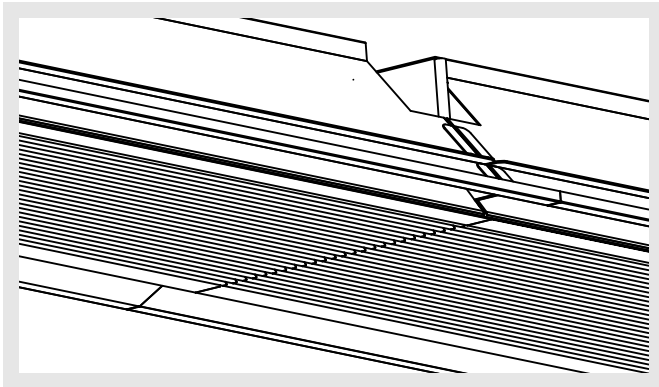

Ceiling induction diffuser DISA-601

Technical data

Performance data

DISA-601-H -...-B -Cooling-

NL (mm)	V		P _s (Pa)	Cooling capacity primary air (W)				Cooling capacity water (W)						Δp _w (kPa)	
	(m ³ /h)	[l/s]		Δt _{Pr} (K)				Δt _{RWV} (K)							
				6	8	10	12	6	7	8	9	10	11	12	
900	18,1	5	50	36	48	60	73	210	246	282	318	354	391	428	14,0
	22,2	6,2	75	44	59	74	89	264	310	355	401	447	494	541	14,0
	25,7	7,1	100	68	68	86	103	304	356	408	461	515	569	623	14,0
	28,7	8	125	77	77	96	115	334	391	450	508	567	627	687	14,0
	31,4	8,7	150	84	84	105	126	358	420	483	546	609	674	738	14,0
	36,3	10	200	97	97	121	145	395	464	533	603	673	745	817	14,0
1200	26,9	7,5	50	54	72	90	108	295	345	395	446	497	549	600	17,4
	32,9	9,1	75	66	88	110	132	367	429	493	556	620	685	750	17,4
	38	11	100	76	101	127	152	418	489	562	634	708	782	857	17,4
	42,5	12	125	85	113	142	170	456	535	614	694	775	856	938	17,4
	46,6	13	150	93	124	155	186	487	571	656	741	828	915	1003	17,4
	53,8	15	200	108	143	179	215	533	626	719	813	908	1005	1102	17,4
1500	34,3	9,5	50	69	91	114	137	371	434	497	561	625	690	755	20,6
	42	12	75	84	112	140	168	448	525	602	679	758	836	916	20,6
	48,5	14	100	97	129	162	194	504	590	678	765	854	943	1033	20,6
	54,2	15	125	108	145	181	217	547	641	736	832	928	1025	1123	20,6
	59,4	17	150	119	158	198	237	582	682	783	885	988	1091	1196	20,6
	68,5	19	200	137	183	228	274	634	744	854	966	1079	1192	1307	20,6
1800	43	12	50	86	115	143	172	453	530	608	686	765	844	923	23,7
	52,7	15	75	105	140	176	211	538	630	723	816	910	1004	1100	23,7
	60,8	17	100	122	162	203	243	599	702	805	910	1015	1121	1228	23,7
	68	19	125	136	181	227	272	646	757	869	982	1096	1211	1326	23,7
	74,5	21	150	149	199	248	298	684	802	920	1040	1161	1283	1406	23,7
	86	24	200	172	229	287	344	741	869	998	1129	1260	1393	1527	23,7
2100	50,4	14	50	101	134	168	202	502	587	673	759	846	933	1021	26,9
	61,7	17	75	123	165	206	247	607	710	815	920	1026	1132	1239	26,9
	71,3	20	100	143	190	238	285	681	797	915	1033	1152	1272	1393	26,9
	79,7	22	125	159	213	266	319	736	862	989	1117	1247	1377	1508	26,9
	87,3	24	150	175	233	291	349	779	912	1047	1184	1321	1459	1599	26,9
	101	28	200	202	269	336	403	842	987	1133	1281	1430	1581	1732	26,9
2400	57,8	16	50	116	154	193	231	560	655	751	847	944	1041	1139	30,1
	70,8	20	75	142	189	236	283	678	794	910	1027	1146	1264	1384	30,1
	81,7	23	100	163	218	272	327	759	889	1020	1152	1285	1418	1553	30,1
	91,4	25	125	183	244	305	366	819	959	1101	1244	1387	1532	1678	30,1
	100	28	150	200	267	334	400	865	1013	1163	1314	1466	1620	1775	30,1
	116	32	200	231	308	385	462	932	1092	1254	1417	1582	1748	1915	30,1
2700	65,9	18	50	132	176	220	263	658	770	883	996	1110	1224	1339	33,3
	80,7	22	75	161	215	269	323	774	907	1040	1174	1309	1444	1581	33,3
	93,1	26	100	186	248	310	373	855	1001	1149	1297	1447	1597	1749	33,3
	104	29	125	208	278	347	417	915	1072	1230	1389	1549	1711	1874	33,3
	114	32	150	228	304	380	456	961	1126	1292	1459	1628	1799	1970	33,3
	132	37	200	263	351	439	527	1028	1205	1383	1563	1744	1927	2111	33,3
3000	73,9	21	50	148	197	246	296	690	807	925	1044	1163	1283	1403	36,5
	90,5	25	75	181	241	302	362	815	954	1094	1234	1376	1518	1662	36,5
	105	29	100	209	279	348	418	903	1058	1213	1370	1527	1686	1846	36,5
	117	33	125	234	312	390	468	970	1136	1304	1472	1642	1813	1985	36,5
	128	36	150	256	341	427	512	1023	1198	1375	1553	1732	1913	2095	36,5
	148	41	200	296	394	493	591	1100	1289	1479	1671	1865	2060	2257	36,5

V_{Wh} = 0.07 l/s corresponds to 250 l/h

Ceiling induction diffuser DISA-601

DISA-601-HT -...-B -Cooling-

NL (mm)	V		P _s (Pa)	Cooling capacity primary air (W)				Cooling capacity water (W)						ΔP _w (kPa)	
	(m ³ /h)	[l/s]		Δt _{pr} (K)				Δt _{RWV} (K)							
				6	8	10	12	6	7	8	9	10	11	12	
900	18,1	5	50	36	48	60	73	208	242	277	312	346	381	416	10,4
	22,2	6,2	75	44	59	74	89	260	304	347	390	434	477	521	10,4
	25,7	7,1	100	68	68	86	103	298	348	397	447	497	546	596	10,4
	28,7	8	125	77	77	96	115	327	381	436	490	545	599	654	10,4
	31,4	8,7	150	84	84	105	126	350	408	467	525	583	642	700	10,4
	36,3	10	200	97	97	121	145	385	449	513	578	642	706	770	10,4
1200	26,9	7,5	50	54	72	90	108	291	340	389	437	486	534	583	12,9
	32,9	9,1	75	66	88	110	132	361	421	481	541	602	662	722	12,9
	38	11	100	76	101	127	152	410	478	547	615	683	752	820	12,9
	42,5	12	125	85	113	142	170	447	521	596	670	745	819	894	12,9
	46,6	13	150	93	124	155	186	476	555	635	714	793	873	952	12,9
	53,8	15	200	108	143	179	215	520	607	693	780	867	953	1040	12,9
1500	34,3	9,5	50	69	91	114	137	367	428	489	550	611	672	733	15,3
	42	12	75	84	112	140	168	442	515	589	662	736	810	883	15,3
	48,5	14	100	97	129	162	194	495	578	661	743	826	908	991	15,3
	54,2	15	125	108	145	181	217	537	626	716	805	894	984	1073	15,3
	59,4	17	150	119	158	198	237	570	665	759	854	949	1044	1139	15,3
	68,5	19	200	137	183	228	274	620	723	826	929	1033	1136	1239	15,3
1800	43	12	50	86	115	143	172	448	523	598	672	747	822	897	17,7
	52,7	15	75	105	140	176	211	530	619	707	796	884	973	1061	17,7
	60,8	17	100	122	162	203	243	589	688	786	884	982	1081	1179	17,7
	68	19	125	136	181	227	272	635	740	846	952	1058	1163	1269	17,7
	74,5	21	150	149	199	248	298	671	782	894	1006	1118	1229	1341	17,7
	86	24	200	172	229	287	344	725	846	967	1088	1209	1330	1450	17,7
2100	50,4	14	50	101	134	168	202	497	580	662	745	828	911	994	20,1
	61,7	17	75	123	165	206	247	599	699	799	898	998	1098	1198	20,1
	71,3	20	100	143	190	238	285	670	782	893	1005	1117	1228	1340	20,1
	79,7	22	125	159	213	266	319	723	843	964	1084	1205	1325	1446	20,1
	87,3	24	150	175	233	291	349	764	891	1019	1146	1273	1404	1528	20,1
	101	28	200	202	269	336	403	824	962	1099	1237	1374	1511	1649	20,1
2400	57,8	16	50	116	154	193	231	555	647	740	832	925	1017	1110	22,5
	70,8	20	75	142	189	236	283	670	781	893	1004	1116	1228	1339	22,5
	81,7	23	100	163	218	272	327	748	873	997	1122	1247	1371	1496	22,5
	91,4	25	125	183	244	305	366	805	940	1074	1208	1342	1477	1611	22,5
	100	28	150	200	267	334	400	849	991	1133	1274	1416	1557	1699	22,5
	116	32	200	231	308	385	462	913	1066	1218	1370	1522	1675	1827	22,5
2700	65,9	18	50	132	176	220	263	652	760	869	977	1086	1195	1303	25
	80,7	22	75	161	215	269	323	765	892	1019	1147	1274	1402	1529	25
	93,1	26	100	186	248	310	373	842	983	1123	1264	1404	1545	1685	25
	104	29	125	208	278	347	417	900	1050	1200	1350	1500	1650	1800	25
	114	32	150	228	304	380	456	944	1101	1259	1416	1573	1731	1888	25
	132	37	200	263	351	439	527	1008	1176	1344	1512	1680	1848	2016	25
3000	73,9	21	50	148	197	246	296	684	798	912	1026	1140	1254	1368	27,3
	90,5	25	75	181	241	302	362	806	940	1074	1208	1343	1477	1611	27,3
	105	29	100	209	279	348	418	891	1040	1188	1337	1485	1634	1782	27,3
	117	33	125	234	312	390	468	956	1115	1274	1433	1593	1752	1911	27,3
	128	36	150	256	341	427	512	1006	1174	1341	1509	1677	1844	2012	27,3
	148	41	200	296	394	493	591	1080	1260	1440	1620	1800	1980	2160	27,3

V_{Wh} = 0.07 l/s corresponds to 250 l/h

Ceiling induction diffuser DISA-601

DISA-601-H -...-C -Cooling-

NL (mm)	V		P _s (Pa)	Cooling capacity primary air (W)				Cooling capacity water (W)						Δp _w (kPa)	
	(m³/h)	[l/s]		Δt _{pr} (K)				Δt _{RWV} (K)							
				6	8	10	12	6	7	8	9	10	11	12	
900	33,4	9,3	50	67	89	111	134	241	282	324	366	408	450	493	14,0
	40,9	11,4	75	82	109	136	164	300	352	404	456	509	562	616	14,0
	47,2	13,1	100	94	126	157	189	343	403	462	523	584	645	707	14,0
	52,8	14,7	125	106	141	176	211	377	442	508	575	642	710	778	14,0
	57,9	16,1	150	116	154	193	231	404	474	545	617	689	762	836	14,0
	66,8	18,6	200	134	178	223	267	446	524	602	682	762	844	926	14,0
1200	49,5	13,7	50	99	132	165	198	340	398	457	516	575	635	695	17,4
	60,6	16,8	75	121	162	202	242	418	490	563	636	709	784	858	17,4
	70	19,4	100	140	187	233	280	474	556	639	722	806	891	977	17,4
	78,2	21,7	125	156	209	261	313	517	607	697	788	881	974	1068	17,4
	85,7	23,8	150	171	229	286	343	552	648	744	842	941	1041	1141	17,4
	99	27,5	200	198	264	330	396	605	710	817	925	1034	1144	1255	17,4
1500	63,1	17,5	50	126	168	210	252	402	471	540	610	680	750	821	20,6
	77,3	21,5	75	155	206	258	309	492	576	661	747	833	920	1008	20,6
	89,2	24,8	100	178	238	297	357	555	651	747	844	942	1041	1140	20,6
	99,8	27,7	125	200	266	333	399	603	707	811	917	1024	1132	1241	20,6
	109,3	30,4	150	219	291	364	437	640	751	862	975	1089	1204	1320	20,6
	126,2	35,1	200	252	337	421	505	696	816	938	1061	1185	1311	1438	20,6
1800	79,2	22	50	158	211	264	317	482	564	647	730	814	898	983	23,7
	97	26,9	75	194	259	323	388	584	684	784	886	988	1091	1195	23,7
	112	31,1	100	224	299	373	448	655	768	882	996	1112	1228	1346	23,7
	125,2	34,8	125	250	334	417	501	709	831	955	1079	1204	1331	1459	23,7
	137,1	38,1	150	274	366	457	549	751	881	1012	1144	1277	1412	1548	23,7
	158,4	44	200	317	422	528	633	813	954	1096	1240	1385	1531	1679	23,7
2100	92,8	25,8	50	186	247	309	371	547	640	734	828	923	1019	1115	26,9
	113,6	31,6	75	227	303	379	455	661	774	888	1003	1118	1235	1352	26,9
	131,2	36,4	100	262	350	437	525	740	867	995	1124	1254	1385	1517	26,9
	146,7	40,8	125	293	391	489	587	798	935	1074	1214	1355	1497	1640	26,9
	160,7	44,6	150	321	429	536	643	843	988	1135	1283	1432	1583	1735	26,9
	185,6	51,5	200	371	495	619	742	909	1065	1224	1384	1545	1709	1873	26,9
2400	106,4	29,6	50	213	284	355	426	608	712	816	921	1026	1132	1239	30,1
	130,3	36,2	75	261	347	434	521	726	850	975	1101	1227	1355	1483	30,1
	150,5	41,8	100	301	401	502	602	807	946	1085	1225	1367	1510	1653	30,1
	168,2	46,7	125	336	449	561	673	867	1016	1166	1317	1470	1624	1779	30,1
	184,3	51,2	150	369	491	614	737	913	1070	1228	1388	1549	1711	1875	30,1
	212,8	59,1	200	426	567	709	851	978	1147	1317	1489	1662	1837	2013	30,1
2700	121,2	33,7	50	242	323	404	485	697	815	935	1055	1176	1297	1420	33,3
	148,5	41,2	75	297	396	495	594	833	976	1119	1264	1409	1556	1703	33,3
	171,5	47,6	100	343	457	572	686	924	1082	1241	1402	1564	1728	1892	33,3
	191,7	53,2	125	383	511	639	767	987	1157	1328	1500	1674	1849	2026	33,3
	210	58,3	150	420	560	700	840	1034	1212	1391	1572	1755	1939	2125	33,3
	242,5	67,4	200	485	647	808	970	1099	1288	1479	1672	1866	2063	2261	33,3
3000	136,1	37,8	50	272	363	454	544	757	886	1015	1146	1277	1408	1541	36,5
	166,7	46,3	75	333	444	556	667	896	1049	1203	1358	1514	1672	1830	36,5
	192,5	53,5	100	385	513	642	770	991	1161	1332	1504	1678	1853	2029	36,5
	215,2	59,8	125	430	574	717	861	1061	1243	1426	1611	1797	1985	2174	36,5
	235,7	65,5	150	471	629	786	943	1113	1305	1498	1692	1888	2086	2285	36,5
	272,2	75,6	200	544	726	907	1089	1188	1393	1599	1807	2018	2229	2443	36,5

V_{Wn} = 0.07 l/s corresponds to 250 l/h

Ceiling induction diffuser DISA-601

DISA-601-HT -...-C -Cooling-

NL (mm)	V		P _s (Pa)	Cooling capacity primary air (W)				Cooling capacity water (W)						ΔP _w (kPa)	
	(m ³ /h)	[l/s]		Δt _{pr} (K)				Δt _{RWV} (K)							
				6	8	10	12	6	7	8	9	10	11	12	
900	33,4	9,3	50	67	89	111	134	238	278	317	357	397	437	476	10,4
	40,9	11,4	75	82	109	136	164	295	344	393	442	491	541	590	10,4
	47,2	13,1	100	94	126	157	189	336	392	448	504	560	616	672	10,4
	52,8	14,7	125	106	141	176	211	368	429	490	552	613	674	736	10,4
	57,9	16,1	150	116	154	193	231	393	459	525	590	656	721	787	10,4
	66,8	18,6	200	134	178	223	267	433	505	577	649	721	793	866	10,4
1200	49,5	13,7	50	99	132	165	198	336	392	447	503	559	615	671	12,9
	60,6	16,8	75	121	162	202	242	411	479	547	616	684	753	821	12,9
	70	19,4	100	140	187	233	280	464	541	619	696	773	851	928	12,9
	78,2	21,7	125	156	209	261	313	505	589	673	757	841	926	1010	12,9
	85,7	23,8	150	171	229	286	343	537	627	717	806	896	985	1075	12,9
	99	27,5	200	198	264	330	396	588	685	783	881	979	1077	1175	12,9
1500	63,1	17,5	50	126	168	210	252	398	464	530	596	663	729	795	15,3
	77,3	21,5	75	155	206	258	309	484	565	645	726	806	887	968	15,3
	89,2	24,8	100	178	238	297	357	544	635	726	817	907	998	1089	15,3
	99,8	27,7	125	200	266	333	399	590	688	786	885	983	1081	1179	15,3
	109,3	30,4	150	219	291	364	437	625	729	834	938	1042	1146	1250	15,3
	126,2	35,1	200	252	337	421	505	678	791	903	1016	1129	1242	1355	15,3
1800	79,2	22	50	158	211	264	317	476	555	635	714	794	873	952	17,7
	97	26,9	75	194	259	323	388	574	670	766	862	957	1053	1149	17,7
	112	31,1	100	224	299	373	448	643	750	858	965	1072	1179	1286	17,7
	125,2	34,8	125	250	334	417	501	695	810	926	1042	1158	1273	1389	17,7
	137,1	38,1	150	274	366	457	549	735	857	979	1102	1224	1347	1469	17,7
	158,4	44	200	317	422	528	633	793	925	1058	1190	1322	1454	1586	17,7
2100	92,8	25,8	50	186	247	309	371	541	631	721	811	901	992	1082	20,1
	113,6	31,6	75	227	303	379	455	651	760	868	977	1085	1194	1302	20,1
	131,2	36,4	100	262	350	437	525	727	848	969	1090	1212	1333	1454	20,1
	146,7	40,8	125	293	391	489	587	783	913	1044	1174	1304	1435	1565	20,1
	160,7	44,6	150	321	429	536	643	826	963	1101	1238	1376	1514	1651	20,1
	185,6	51,5	200	371	495	619	742	888	1036	1184	1332	1479	1627	1775	20,1
2400	106,4	29,6	50	213	284	355	426	602	702	802	903	1003	1103	1204	22,5
	130,3	36,2	75	261	347	434	521	716	835	954	1074	1193	1312	1432	22,5
	150,5	41,8	100	301	401	502	602	794	926	1059	1191	1323	1456	1588	22,5
	168,2	46,7	125	336	449	561	673	851	993	1135	1277	1419	1561	1703	22,5
	184,3	51,2	150	369	491	614	737	895	1044	1194	1343	1492	1641	1790	22,5
	212,8	59,1	200	426	567	709	851	958	1117	1277	1437	1596	1756	1915	22,5
2700	121,2	33,7	50	242	323	404	485	689	804	919	1034	1149	1264	1379	25
	148,5	41,2	75	297	396	495	594	821	958	1095	1232	1369	1506	1643	25
	171,5	47,6	100	343	457	572	686	908	1060	1211	1362	1514	1665	1816	25
	191,7	53,2	125	383	511	639	767	969	1131	1292	1454	1616	1777	1939	25
	210	58,3	150	420	560	700	840	1014	1183	1352	1521	1690	1859	2029	25
	242,5	67,4	200	485	647	808	970	1076	1255	1434	1614	1793	1972	2151	25
3000	136,1	37,8	50	272	363	454	544	749	874	999	1124	1248	1373	1498	27,3
	166,7	46,3	75	333	444	556	667	884	1031	1178	1326	1473	1620	1768	27,3
	192,5	53,5	100	385	513	642	770	976	1138	1301	1463	1626	1789	1951	27,3
	215,2	59,8	125	430	574	717	861	1042	1216	1390	1564	1737	1911	2085	27,3
	235,7	65,5	150	471	629	786	943	1093	1275	1457	1639	1822	2004	2186	27,3
	272,2	75,6	200	544	726	907	1089	1165	1359	1553	1747	1941	2135	2329	27,3

V_{Wn} = 0.07 l/s corresponds to 250 l/h

Ceiling induction diffuser DISA-601

DISA-601-H -...-D -Cooling-

NL (mm)	V		P _s (Pa)	Cooling capacity primary air (W)				Cooling capacity water (W)						Δp _w (kPa)	
	(m³/h)	[l/s]		Δt _{pr} (K)				Δt _{rwv} (K)							
				6	8	10	12	6	7	8	9	10	11	12	
900	50,2	13,9	50	100	134	167	201	274	321	368	416	464	512	561	14,0
	61,4	17,1	75	123	164	205	246	330	387	444	502	561	620	679	14,0
	71	19,7	100	142	189	237	284	371	435	500	565	631	698	765	14,0
	79,3	22	125	159	212	264	317	402	472	542	613	685	758	832	14,0
	86,9	24,1	150	174	232	290	348	427	501	576	652	729	806	885	14,0
	100,3	27,9	200	201	268	334	401	464	545	627	710	794	879	965	14,0
1200	74,3	20,6	50	149	198	248	297	372	436	500	565	630	696	762	17,4
	91	25,3	75	182	243	303	364	446	522	600	678	757	836	916	17,4
	105,1	29,2	100	210	280	350	420	499	585	672	760	849	939	1029	17,4
	117,5	32,6	125	235	313	392	470	540	633	728	823	920	1017	1116	17,4
	128,7	35,8	150	257	343	429	515	573	672	772	874	977	1080	1185	17,4
	148,7	41,3	200	297	396	496	595	621	730	839	950	1062	1175	1290	17,4
1500	94,8	26,3	50	190	253	316	379	448	525	602	680	758	837	916	20,6
	116,1	32,2	75	232	310	387	464	533	625	717	810	904	999	1094	20,6
	134	37,2	100	268	357	447	536	593	696	799	903	1008	1114	1221	20,6
	149,8	41,6	125	300	400	499	599	638	749	860	973	1086	1201	1317	20,6
	164,2	45,6	150	328	438	547	657	674	790	908	1027	1148	1269	1392	20,6
	189,5	52,7	200	379	505	632	758	726	852	980	1109	1239	1370	1503	20,6
1800	118,9	33	50	238	317	396	476	529	620	711	802	895	988	1081	23,7
	145,7	40,5	75	291	388	486	583	626	733	841	950	1060	1171	1283	23,7
	168,2	46,7	100	336	449	561	673	693	812	933	1054	1177	1300	1425	23,7
	188	52,2	125	376	501	627	752	744	872	1001	1132	1264	1397	1531	23,7
	206	57,2	150	412	549	687	824	783	918	1055	1193	1332	1473	1615	23,7
	237,9	66,1	200	476	634	793	951	840	986	1133	1281	1432	1583	1737	23,7
2100	139,4	38,7	50	279	372	465	557	622	728	835	943	1052	1161	1271	26,9
	170,7	47,4	75	341	455	569	683	730	856	982	1109	1238	1367	1498	26,9
	197,1	54,8	100	394	526	657	788	806	945	1084	1226	1368	1511	1656	26,9
	220,4	61,2	125	441	588	735	881	862	1011	1161	1312	1465	1619	1774	26,9
	241,4	67,1	150	483	644	805	966	905	1062	1219	1379	1540	1702	1866	26,9
	278,7	77,4	200	557	743	929	1115	968	1136	1305	1476	1649	1823	2000	26,9
2400	159,8	44,4	50	320	426	533	639	694	813	932	1052	1173	1295	1418	30,1
	195,7	54,4	75	391	522	652	783	810	948	1088	1229	1371	1514	1658	30,1
	226	62,8	100	452	603	753	904	892	1045	1199	1355	1512	1671	1831	30,1
	252,7	70,2	125	505	674	842	1011	954	1118	1284	1451	1620	1790	1962	30,1
	276,8	76,9	150	554	738	923	1107	1003	1176	1351	1527	1705	1885	2066	30,1
	319,6	88,8	200	639	852	1065	1278	1078	1264	1452	1642	1834	2028	2224	30,1
2700	182,1	50,6	50	364	486	607	728	762	893	1023	1155	1288	1421	1556	33,3
	223	62	75	446	595	743	892	882	1033	1185	1338	1492	1648	1805	33,3
	257,5	71,5	100	515	687	858	1030	965	1131	1298	1467	1636	1807	1980	33,3
	287,9	80	125	576	768	960	1152	1028	1205	1383	1563	1744	1927	2111	33,3
	315,4	87,6	150	631	841	1051	1262	1077	1262	1449	1638	1828	2020	2214	33,3
	408,8	113,6	200	818	1090	1363	1635	1147	1345	1545	1747	1951	2156	2364	33,3
3000	204,4	56,8	50	409	545	681	818	821	961	1102	1243	1386	1530	1674	36,5
	250,4	69,5	75	501	668	835	1001	958	1122	1287	1453	1621	1789	1959	36,5
	289,1	80,3	100	578	771	964	1156	1052	1232	1414	1597	1782	1968	2156	36,5
	323,2	89,9	125	646	862	1077	1293	1121	1313	1508	1704	1901	2100	2301	36,5
	354	98,3	150	708	944	1180	1416	1174	1376	1579	1785	1992	2201	2412	36,5
	408,8	113,6	200	818	1090	1363	1635	1250	1466	1683	1903	2125	2348	2574	36,5

V_{Wn} = 0.07 l/s corresponds to 250 l/h

Ceiling induction diffuser DISA-601

DISA-601-HT -...-D -Cooling-

NL (mm)	V		P _s (Pa)	Cooling capacity primary air (W)				Cooling capacity water (W)						ΔP _w (kPa)	
	(m ³ /h)	[l/s]		Δt _{pr} (K)				Δt _{RWV} (K)							
				6	8	10	12	6	7	8	9	10	11	12	
900	50,2	13,9	50	100	134	167	201	270	314	359	404	449	494	539	10,4
	61,4	17,1	75	123	164	205	246	323	377	431	485	539	593	647	10,4
	71	19,7	100	142	189	237	284	362	422	483	543	603	664	724	10,4
	79,3	22	125	159	212	264	317	391	457	522	587	652	718	783	10,4
	86,9	24,1	150	174	232	290	348	415	484	553	622	691	761	830	10,4
	100,3	27,9	200	201	268	334	401	450	525	600	675	750	825	900	10,4
1200	74,3	20,6	50	149	198	248	297	366	427	488	549	611	672	733	12,9
	91	25,3	75	182	243	303	364	437	510	583	655	728	801	874	12,9
	105,1	29,2	100	210	280	350	420	488	569	650	731	813	894	975	12,9
	117,5	32,6	125	235	313	392	470	526	614	702	789	877	965	1052	12,9
	128,7	35,8	150	257	343	429	515	557	650	742	835	928	1021	1114	12,9
	148,7	41,3	200	297	396	496	595	603	703	804	904	1005	1105	1205	12,9
1500	94,8	26,3	50	190	253	316	379	442	515	589	663	736	810	884	15,3
	116,1	32,2	75	232	310	387	464	523	611	698	785	872	960	1047	15,3
	134	37,2	100	268	357	447	536	581	678	774	871	968	1065	1162	15,3
	149,8	41,6	125	300	400	499	599	624	728	832	935	1039	1143	1247	15,3
	164,2	45,6	150	328	438	547	657	657	767	876	986	1095	1205	1314	15,3
	189,5	52,7	200	379	505	632	758	707	824	942	1060	1178	1295	1413	15,3
1800	118,9	33	50	238	317	396	476	522	609	696	783	870	957	1044	17,7
	145,7	40,5	75	291	388	486	583	615	717	820	922	1024	1127	1229	17,7
	168,2	46,7	100	336	449	561	673	679	792	906	1019	1132	1245	1358	17,7
	188	52,2	125	376	501	627	752	727	848	970	1091	1212	1333	1454	17,7
	206	57,2	150	412	549	687	824	764	892	1019	1147	1274	1401	1529	17,7
	237,9	66,1	200	476	634	793	951	819	955	1092	1228	1365	1501	1638	17,7
2100	139,4	38,7	50	279	372	465	557	614	716	818	920	1023	1125	1227	20,1
	170,7	47,4	75	341	455	569	683	718	838	957	1077	1196	1316	1436	20,1
	197,1	54,8	100	394	526	657	788	790	922	1053	1185	1317	1448	1580	20,1
	220,4	61,2	125	441	588	735	881	843	984	1125	1265	1406	1546	1687	20,1
	241,4	67,1	150	483	644	805	966	885	1032	1179	1327	1474	1622	1769	20,1
	278,7	77,4	200	557	743	929	1115	944	1101	1259	1416	1573	1731	1888	20,1
2400	159,8	44,4	50	320	426	533	639	685	800	914	1028	1142	1257	1371	22,5
	195,7	54,4	75	391	522	652	783	796	929	1062	1195	1327	1460	1593	22,5
	226	62,8	100	452	603	753	904	875	1021	1167	1313	1458	1604	1750	22,5
	252,7	70,2	125	505	674	842	1011	935	1090	1246	1402	1558	1713	1869	22,5
	276,8	76,9	150	554	738	923	1107	981	1145	1309	1472	1636	1799	1963	22,5
	319,6	88,8	200	639	852	1065	1278	1052	1227	1403	1578	1753	1929	2104	22,5
2700	182,1	50,6	50	364	486	607	728	753	878	1004	1129	1255	1380	1506	25
	223	62	75	446	595	743	892	868	1013	1157	1302	1447	1591	1736	25
	257,5	71,5	100	515	687	858	1030	948	1107	1265	1423	1581	1739	1897	25
	287,9	80	125	576	768	960	1152	1008	1176	1344	1512	1680	1848	2017	25
	315,4	87,6	150	631	841	1051	1262	1055	1230	1406	1582	1758	1933	2109	25
	408,8	113,6	200	818	1090	1363	1635	1122	1309	1496	1683	1870	2057	2244	25
3000	204,4	56,8	50	409	545	681	818	811	946	1082	1217	1352	1487	1623	27,3
	250,4	69,5	75	501	668	835	1001	944	1101	1258	1415	1573	1730	1887	27,3
	289,1	80,3	100	578	771	964	1156	1034	1206	1379	1551	1723	1896	2068	27,3
	323,2	89,9	125	646	862	1077	1293	1100	1283	1467	1650	1833	2017	2200	27,3
	354	98,3	150	708	944	1180	1416	1151	1342	1534	1726	1918	2109	2301	27,3
	408,8	113,6	200	818	1090	1363	1635	1224	1427	1631	1835	2039	2243	2447	27,3

V_{Wh} = 0.07 l/s corresponds to 250 l/h

Ceiling induction diffuser DISA-601

DISA-601-H -...-E -Cooling-

NL (mm)	V		P _s (Pa)	Cooling capacity primary air (W)				Cooling capacity water (W)						Δp _w (kPa)	
	(m ³ /h)	[l/s]		Δt _{pr} (K)				Δt _{rwv} (K)							
				6	8	10	12	6	7	8	9	10	11	12	
900	84,8	23,6	50	170	226	283	339	345	405	465	526	587	649	711	14,0
	103,9	28,9	75	208	277	346	416	392	460	529	598	668	739	811	14,0
	119,9	33,3	100	240	320	400	480	426	500	574	650	727	804	882	14,0
	134,1	37,3	125	268	358	447	536	451	530	610	690	771	854	937	14,0
	146,9	40,8	150	294	392	490	588	472	554	638	722	808	894	982	14,0
	169,6	47,1	200	339	452	565	679	504	592	682	772	864	957	1051	14,0
1200	125,7	34,9	50	251	335	419	503	445	522	599	678	756	836	916	17,4
	153,9	42,7	75	308	410	513	616	502	588	676	764	853	943	1034	17,4
	177,7	49,4	100	355	474	592	711	541	634	729	824	921	1018	1117	17,4
	198,7	55,2	125	397	530	662	795	570	668	768	869	971	1075	1179	17,4
	217,6	60,5	150	435	580	725	871	592	695	799	905	1011	1119	1228	17,4
	251,3	69,8	200	503	670	838	1005	627	736	846	958	1071	1186	1302	17,4
1500	160,2	44,5	50	320	427	534	641	541	634	727	822	917	1013	1110	20,6
	196,2	54,5	75	392	523	654	785	609	714	820	927	1035	1143	1253	20,6
	226,6	62,9	100	453	604	755	906	656	769	883	999	1116	1234	1353	20,6
	253,3	70,4	125	507	675	844	1013	691	810	931	1053	1177	1302	1428	20,6
	277,5	77,1	150	555	740	925	1110	718	843	969	1096	1225	1355	1487	20,6
	320,4	89	200	641	854	1068	1282	761	893	1027	1163	1300	1438	1578	20,6
1800	201	55,8	50	402	536	670	804	620	726	833	941	1050	1160	1270	23,7
	246,2	68,4	75	492	657	821	985	692	811	932	1053	1175	1299	1423	23,7
	284,3	79	100	569	758	948	1137	742	870	999	1129	1261	1394	1528	23,7
	317,9	88,3	125	636	848	1060	1271	778	913	1048	1186	1324	1464	1605	23,7
	348,2	96,7	150	696	929	1161	1393	807	946	1087	1229	1373	1518	1665	23,7
	402,1	111,7	200	804	1072	1340	1608	849	996	1145	1295	1447	1601	1756	23,7
2100	235,6	65,4	50	471	628	785	942	734	859	986	1114	1243	1373	1504	26,9
	288,5	80,2	75	577	769	962	1154	813	953	1094	1237	1380	1525	1671	26,9
	333,2	92,5	100	666	888	1111	1333	867	1017	1168	1320	1474	1629	1786	26,9
	372,5	103,5	125	745	993	1242	1490	907	1064	1222	1382	1543	1706	1870	26,9
	408,1	113,4	150	816	1088	1360	1632	939	1101	1265	1430	1598	1766	1937	26,9
	471,2	130,9	200	942	1257	1571	1885	988	1159	1332	1506	1683	1861	2041	26,9
2400	270,1	75	50	540	720	900	1081	805	943	1082	1222	1363	1506	1649	30,1
	330,9	91,9	75	662	882	1103	1323	892	1045	1200	1356	1513	1672	1831	30,1
	382	106,1	100	764	1019	1273	1528	950	1114	1279	1446	1614	1783	1954	30,1
	427,1	118,7	125	854	1139	1424	1709	993	1164	1337	1511	1687	1865	2044	30,1
	467,9	130	150	936	1248	1560	1872	1026	1203	1382	1563	1745	1929	2115	30,1
	540,3	150,1	200	1081	1441	1801	2161	1079	1266	1454	1645	1837	2031	2227	30,1
2700	307,8	85,5	50	616	821	1026	1231	887	1039	1192	1346	1501	1658	1815	33,3
	377	104,7	75	754	1005	1257	1508	981	1149	1319	1490	1663	1837	2012	33,3
	435,4	120,9	100	871	1161	1451	1741	1047	1227	1409	1592	1777	1964	2152	33,3
	486,7	135,2	125	973	1298	1622	1947	1098	1287	1478	1670	1865	2061	2259	33,3
	533,2	148,1	150	1066	1422	1777	2133	1138	1334	1533	1733	1935	2138	2344	33,3
	615,7	171	200	1231	1642	2052	2463	1201	1409	1618	1830	2044	2260	2478	33,3
3000	345,5	96	50	691	921	1152	1382	947	1109	1272	1436	1602	1768	1936	36,5
	423,2	117,6	75	846	1129	1411	1693	1046	1225	1406	1588	1772	1957	2144	36,5
	488,7	135,7	100	977	1303	1629	1955	1113	1305	1498	1692	1888	2086	2285	36,5
	546,3	151,8	125	1093	1457	1821	2185	1163	1363	1565	1768	1973	2181	2389	36,5
	598,5	166,2	150	1197	1596	1995	2394	1201	1408	1617	1828	2040	2254	2471	36,5
	691,1	192	200	1382	1843	2304	2764	1260	1477	1697	1918	2142	2367	2595	36,5

V_{Wn} = 0.07 l/s corresponds to 250 l/h

Ceiling induction diffuser DISA-601

DISA-601-HT -...-E -Cooling-

NL (mm)	V		P _s (Pa)	Cooling capacity primary air (W)				Cooling capacity water (W)						ΔP _w (kPa)	
	(m ³ /h)	[l/s]		Δt _{pr} (K)				Δt _{RWV} (K)							
				6	8	10	12	6	7	8	9	10	11	12	
900	84,8	23,6	50	170	226	283	339	338	394	450	507	563	619	676	10,4
	103,9	28,9	75	208	277	346	416	382	446	510	573	637	701	764	10,4
	119,9	33,3	100	240	320	400	480	414	483	552	621	690	759	827	10,4
	134,1	37,3	125	268	358	447	536	438	511	584	657	730	803	876	10,4
	146,9	40,8	150	294	392	490	588	457	533	609	686	762	838	914	10,4
	169,6	47,1	200	339	452	565	679	487	568	649	730	811	892	974	10,4
1200	125,7	34,9	50	251	335	419	503	437	509	582	655	728	800	873	12,9
	153,9	42,7	75	308	410	513	616	490	572	653	735	817	898	980	12,9
	177,7	49,4	100	355	474	592	711	527	615	702	790	878	966	1053	12,9
	198,7	55,2	125	397	530	662	795	554	646	739	831	923	1016	1108	12,9
	217,6	60,5	150	435	580	725	871	575	671	767	863	959	1055	1151	12,9
	251,3	69,8	200	503	670	838	1005	608	709	810	912	1013	1114	1215	12,9
1500	160,2	44,5	50	320	427	534	641	531	619	708	796	885	973	1061	15,3
	196,2	54,5	75	392	523	654	785	595	695	794	893	992	1092	1191	15,3
	226,6	62,9	100	453	604	755	906	640	747	853	960	1067	1173	1280	15,3
	253,3	70,4	125	507	675	844	1013	673	785	897	1010	1122	1234	1346	15,3
	277,5	77,1	150	555	740	925	1110	699	816	932	1049	1165	1282	1398	15,3
	320,4	89	200	641	854	1068	1282	739	862	986	1109	1232	1355	1479	15,3
1800	201	55,8	50	402	536	670	804	609	710	812	913	1015	1116	1218	17,7
	246,2	68,4	75	492	657	821	985	678	791	905	1018	1131	1244	1357	17,7
	284,3	79	100	569	758	948	1137	726	847	967	1088	1209	1330	1451	17,7
	317,9	88,3	125	636	848	1060	1271	760	887	1014	1140	1267	1394	1520	17,7
	348,2	96,7	150	696	929	1161	1393	787	918	1049	1181	1312	1443	1574	17,7
	402,1	111,7	200	804	1072	1340	1608	827	965	1103	1241	1379	1517	1655	17,7
2100	235,6	65,4	50	471	628	785	942	721	841	961	1081	1201	1321	1442	20,1
	288,5	80,2	75	577	769	962	1154	797	930	1063	1195	1328	1461	1594	20,1
	333,2	92,5	100	666	888	1111	1333	848	990	1131	1273	1414	1555	1697	20,1
	372,5	103,5	125	745	993	1242	1490	886	1034	1182	1330	1477	1625	1773	20,1
	408,1	113,4	150	816	1088	1360	1632	916	1069	1222	1374	1527	1680	1832	20,1
	471,2	130,9	200	942	1257	1571	1885	963	1123	1283	1444	1604	1765	1925	20,1
2400	270,1	75	50	540	720	900	1081	792	924	1056	1188	1320	1452	1584	22,5
	330,9	91,9	75	662	882	1103	1323	875	1021	1167	1313	1459	1605	1751	22,5
	382	106,1	100	764	1019	1273	1528	931	1086	1241	1396	1552	1707	1862	22,5
	427,1	118,7	125	854	1139	1424	1709	972	1133	1295	1457	1619	1781	1943	22,5
	467,9	130	150	936	1248	1560	1872	1003	1171	1338	1505	1672	1839	2007	22,5
	540,3	150,1	200	1081	1441	1801	2161	1053	1229	1404	1580	1756	1931	2107	22,5
2700	307,8	85,5	50	616	821	1026	1231	873	1019	1164	1310	1455	1601	1746	25
	377	104,7	75	754	1005	1257	1508	963	1124	1284	1445	1605	1766	1926	25
	435,4	120,9	100	871	1161	1451	1741	1027	1198	1369	1540	1711	1882	2053	25
	486,7	135,2	125	973	1298	1622	1947	1075	1254	1433	1612	1791	1970	2150	25
	533,2	148,1	150	1066	1422	1777	2133	1113	1299	1484	1670	1855	2041	2226	25
	615,7	171	200	1231	1642	2052	2463	1173	1369	1564	1760	1955	2151	2346	25
3000	345,5	96	50	691	921	1152	1382	933	1088	1244	1399	1555	1710	1866	27,3
	423,2	117,6	75	846	1129	1411	1693	1028	1200	1371	1542	1714	1885	2057	27,3
	488,7	135,7	100	977	1303	1629	1955	1093	1275	1457	1639	1821	2004	2186	27,3
	546,3	151,8	125	1093	1457	1821	2185	1140	1330	1520	1710	1900	2090	2280	27,3
	598,5	166,2	150	1197	1596	1995	2394	1177	1373	1569	1765	1962	2158	2354	27,3
	691,1	192	200	1382	1843	2304	2764	1233	1438	1644	1849	2055	2260	2466	27,3

V_{Wh} = 0.07 l/s corresponds to 250 l/h

Ceiling induction diffuser DISA-601

DISA-601-H -...-B -Heating-

NL (mm)	V		P _s (Pa)	Heating capacity primary air (W)				Heating capacity water (W)							ΔP _w (kPa)
	(m ³ /h)	[l/s]		Δt _{pr} (K)				Δt _{rwv} (K)							
				6	8	10	12	16	18	20	22	24	26	28	
900	18,1	5	50	36	48	60	73	512	579	647	715	785	855	924	5,6
	22,2	6,2	75	44	59	74	89	642	726	812	901	989	1078	1169	5,6
	25,7	7,1	100	51	68	86	103	736	834	934	1035	1138	1242	1347	5,6
	28,7	8	125	57	77	96	115	809	917	1027	1139	1253	1369	1486	5,6
	31,4	8,7	150	63	84	105	126	866	983	1103	1223	1346	1471	1597	5,6
	36,3	10,1	200	73	97	121	145	954	1083	1216	1350	1487	1626	1767	5,6
1200	26,9	7,5	50	54	72	90	108	701	793	886	979	1074	1170	1267	6,9
	32,9	9,1	75	66	88	110	132	867	981	1097	1215	1334	1455	1577	6,9
	38	10,6	100	76	101	127	152	982	1114	1246	1381	1517	1656	1796	6,9
	42,5	11,8	125	85	113	142	170	1070	1213	1358	1506	1656	1808	1961	6,9
	46,6	12,9	150	93	124	155	186	1137	1291	1445	1604	1763	1927	2091	6,9
	53,8	14,9	200	108	143	179	215	1239	1406	1576	1749	1926	2105	2286	6,9
1500	34,3	9,5	50	69	91	114	137	882	998	1114	1233	1351	1471	1594	8,2
	42	11,7	75	84	112	140	168	1058	1198	1340	1483	1628	1775	1923	8,2
	48,5	13,5	100	97	129	162	194	1185	1342	1502	1664	1828	1994	2162	8,2
	54,2	15,1	125	108	145	181	217	1282	1453	1627	1803	1981	2162	2346	8,2
	59,4	16,5	150	119	158	198	237	1359	1541	1726	1913	2103	2296	2491	8,2
	68,5	19	200	137	183	228	274	1473	1672	1874	2078	2286	2497	2712	8,2
1800	43	11,9	50	86	115	143	172	1065	1204	1346	1488	1632	1778	1924	9,5
	52,7	14,6	75	105	140	176	211	1254	1420	1586	1756	1928	2101	2276	9,5
	60,8	16,9	100	122	162	203	243	1389	1573	1759	1948	2139	2333	2529	9,5
	68	18,9	125	136	181	227	272	1491	1690	1890	2095	2302	2511	2723	9,5
	74,5	20,7	150	149	199	248	298	1572	1782	1995	2211	2430	2652	2877	9,5
	86	23,9	200	172	229	287	344	1694	1920	2151	2385	2623	2864	3108	9,5
2100	50,4	14	50	101	134	168	202	1171	1324	1479	1634	1792	1951	2111	10,8
	61,7	17,1	75	123	165	206	247	1399	1584	1770	1958	2149	2341	2536	10,8
	71,3	19,8	100	143	190	238	285	1558	1764	1973	2183	2397	2614	2832	10,8
	79,7	22,1	125	159	213	266	319	1674	1896	2122	2350	2581	2815	3052	10,8
	87,3	24,2	150	175	233	291	349	1764	1999	2237	2478	2723	2971	3222	10,8
	100,8	28	200	202	269	336	403	1893	2147	2403	2664	2928	3196	3468	10,8
2400	57,8	16,1	50	116	154	193	231	1296	1464	1635	1807	1981	2156	2333	12,1
	70,8	19,7	75	142	189	236	283	1548	1753	1958	2167	2377	2589	2803	12,1
	81,7	22,7	100	163	218	272	327	1720	1947	2177	2410	2644	2883	3123	12,1
	91,4	25,4	125	183	244	305	366	1843	2087	2334	2585	2838	3095	3355	12,1
	100,1	27,8	150	200	267	334	400	1936	2193	2454	2717	2985	3256	3530	12,1
	115,6	32,1	200	231	308	385	462	2067	2343	2622	2906	3193	3484	3778	12,1
2700	65,9	18,3	50	132	176	220	263	1504	1701	1899	2099	2301	2505	2711	13,5
	80,7	22,4	75	161	215	269	323	1747	1976	2208	2443	2680	2919	3162	13,5
	93,1	25,9	100	186	248	310	373	1912	2164	2420	2678	2939	3203	3470	13,5
	104,1	28,9	125	208	278	347	417	2032	2301	2573	2849	3128	3409	3695	13,5
	114,1	31,7	150	228	304	380	456	2123	2404	2690	2978	3270	3566	3867	13,5
	131,7	36,6	200	263	351	439	527	2252	2552	2855	3163	3474	3790	4110	13,5
3000	73,9	20,5	50	148	197	246	296	1572	1777	1983	2192	2402	2614	2828	14,7
	90,5	25,1	75	181	241	302	362	1825	2066	2307	2551	2797	3046	3298	14,7
	104,5	29	100	209	279	348	418	2003	2267	2533	2802	3075	3350	3628	14,7
	116,9	32,5	125	234	312	390	468	2135	2416	2701	2990	3281	3576	3874	14,7
	128	35,6	150	256	341	427	512	2237	2532	2831	3135	3441	3751	4065	14,7
	147,8	41,1	200	296	394	493	591	2383	2699	3019	3344	3672	4005	4341	14,7

V_{Wn} = 0.0416 l/s corresponds to 150 l/h

Ceiling induction diffuser DISA-601

DISA-601-HT -...-B -Heating-

NL (mm)	V		P _s (Pa)	Heating capacity primary air (W)				Heating capacity water (W)							ΔP _w (kPa)
	(m ³ /h)	[l/s]		Δt _{pr} (K)				Δt _{RWV} (K)							
				6	8	10	12	16	18	20	22	24	26	28	
900	18,1	5	50	36	48	60	73	394	444	493	542	591	641	690	1,3
	22,2	6,2	75	44	59	74	89	492	554	615	677	738	800	862	1,3
	25,7	7,1	100	51	68	86	103	563	633	703	774	844	914	985	1,3
	28,7	8	125	57	77	96	115	616	693	771	848	925	1002	1079	1,3
	31,4	8,7	150	63	84	105	126	659	742	824	906	989	1071	1154	1,3
	36,3	10,1	200	73	97	121	145	724	814	905	995	1086	1176	1267	1,3
1200	26,9	7,5	50	54	72	90	108	543	611	679	747	815	882	950	1,6
	32,9	9,1	75	66	88	110	132	669	752	836	919	1003	1087	1170	1,6
	38	10,6	100	76	101	127	152	756	851	945	1040	1134	1229	1323	1,6
	42,5	11,8	125	85	113	142	170	821	924	1027	1129	1232	1335	1437	1,6
	46,6	12,9	150	93	124	155	186	872	982	1091	1200	1309	1418	1527	1,6
	53,8	14,9	200	108	143	179	215	949	1068	1187	1305	1424	1543	1661	1,6
1500	34,3	9,5	50	69	91	114	137	689	775	861	948	1034	1120	1206	2
	42	11,7	75	84	112	140	168	827	930	1033	1137	1240	1343	1446	2
	48,5	13,5	100	97	129	162	194	925	1041	1156	1272	1387	1503	1619	2
	54,2	15,1	125	108	145	181	217	1000	1125	1250	1375	1500	1625	1750	2
	59,4	16,5	150	119	158	198	237	1060	1192	1325	1457	1590	1722	1854	2
	68,5	19	200	137	183	228	274	1150	1293	1437	1581	1724	1868	2012	2
1800	43	11,9	50	86	115	143	172	839	944	1048	1153	1258	1363	1468	2,3
	52,7	14,6	75	105	140	176	211	988	1112	1235	1359	1482	1606	1729	2,3
	60,8	16,9	100	122	162	203	243	1095	1231	1368	1505	1642	1779	1915	2,3
	68	18,9	125	136	181	227	272	1176	1322	1469	1616	1763	1910	2057	2,3
	74,5	20,7	150	149	199	248	298	1240	1395	1550	1705	1860	2015	2170	2,3
	86	23,9	200	172	229	287	344	1337	1504	1671	1838	2005	2172	2339	2,3
2100	50,4	14	50	101	134	168	202	927	1042	1158	1274	1390	1506	1622	2,6
	61,7	17,1	75	123	165	206	247	1110	1249	1387	1526	1665	1804	1942	2,6
	71,3	19,8	100	143	190	238	285	1237	1392	1547	1701	1865	2011	2165	2,6
	79,7	22,1	125	159	213	266	319	1332	1498	1665	1831	1998	2164	2331	2,6
	87,3	24,2	150	175	233	291	349	1405	1581	1756	1932	2107	2283	2459	2,6
	100,8	28	200	202	269	336	403	1512	1701	1890	2079	2268	2457	2646	2,6
2400	57,8	16,1	50	116	154	193	231	1032	1161	1290	1419	1548	1677	1807	3
	70,8	19,7	75	142	189	236	283	1239	1393	1548	1703	1858	2013	2167	3
	81,7	22,7	100	163	218	272	327	1378	1550	1722	1895	2067	2239	2411	3
	91,4	25,4	125	183	244	305	366	1479	1664	1849	2033	2218	2403	2588	3
	100,1	27,8	150	200	267	334	400	1555	1750	1944	2139	2333	2528	2722	3
	115,6	32,1	200	231	308	385	462	1665	1873	2082	2290	2498	2706	2914	3
2700	65,9	18,3	50	132	176	220	263	1205	1356	1507	1657	1808	1959	2109	3,3
	80,7	22,4	75	161	215	269	323	1405	1581	1756	1932	2108	2283	2459	3,3
	93,1	25,9	100	186	248	310	373	1542	1743	1927	2120	2313	2505	2698	3,3
	104,1	28,9	125	208	278	347	417	1641	1847	2052	2257	2462	2667	2872	3,3
	114,1	31,7	150	228	304	380	456	1717	1932	2147	2361	2576	2791	3005	3,3
	131,7	36,6	200	263	351	439	527	1827	2055	2283	2512	2740	2968	3197	3,3
3000	73,9	20,5	50	148	197	246	296	1264	1422	1580	1738	1896	2054	2212	3,6
	90,5	25,1	75	181	241	302	362	1483	1668	1853	2039	2224	2409	2595	3,6
	104,5	29	100	209	279	348	418	1634	1838	2042	2246	2451	2655	2859	3,6
	116,9	32,5	125	234	312	390	468	1745	1963	2182	2400	2618	2836	3054	3,6
	128	35,6	150	256	341	427	512	1831	2060	2288	2517	2746	2975	3204	3,6
	147,8	41,1	200	296	394	493	591	1954	2198	2442	2687	2931	3175	3419	3,6

V_{Wh} = 0.0416 l/s corresponds to 150 l/h

Ceiling induction diffuser DISA-601

DISA-601-H -...-C -Heating-

NL (mm)	V		P _s (Pa)	Heating capacity primary air (W)				Heating capacity water (W)							Δp _w (kPa)
	(m ³ /h)	[l/s]		Δt _{pr} (K)				Δt _{RWV} (K)							
				6	8	10	12	16	18	20	22	24	26	28	
900	33,4	9,3	50	67	89	111	134	585	663	741	820	900	981	1062	5,6
	40,9	11,4	75	82	109	136	164	725	822	920	1019	1121	1223	1327	5,6
	47,2	13,1	100	94	126	157	189	827	938	1052	1166	1283	1402	1521	5,6
	52,8	14,7	125	106	141	176	211	906	1029	1153	1280	1409	1540	1674	5,6
	57,9	16,1	150	116	154	193	231	969	1102	1236	1372	1511	1653	1796	5,6
	66,8	18,6	200	134	178	223	267	1066	1212	1361	1513	1667	1825	1985	5,6
1200	49,5	13,7	50	99	132	165	198	801	906	1013	1121	1230	1341	1452	6,9
	60,6	16,8	75	121	162	202	242	978	1109	1241	1375	1511	1649	1788	6,9
	70	19,4	100	140	187	233	280	1104	1253	1403	1556	1712	1869	2026	6,9
	78,2	21,7	125	156	209	261	313	1200	1362	1526	1694	1863	2036	2212	6,9
	85,7	23,8	150	171	229	286	343	1275	1448	1624	1803	1984	2169	2357	6,9
	99	27,5	200	198	264	330	396	1389	1578	1771	1967	2167	2370	2577	6,9
1500	63,1	17,5	50	126	168	210	252	952	1078	1205	1333	1462	1593	1725	8,2
	77,3	21,5	75	155	206	258	309	1156	1309	1465	1622	1782	1942	2106	8,2
	89,2	24,8	100	178	238	297	357	1298	1471	1648	1826	2007	2190	2377	8,2
	99,8	27,7	125	200	266	333	399	1404	1593	1784	1979	2176	2377	2579	8,2
	109,3	30,4	150	219	291	364	437	1487	1688	1891	2098	2308	2521	2738	8,2
	126,2	35,1	200	252	337	421	505	1609	1827	2048	2274	2503	2735	2972	8,2
1800	79,2	22	50	158	211	264	317	1122	1269	1419	1569	1721	1875	2030	9,5
	97	26,9	75	194	259	323	388	1344	1522	1702	1885	2070	2256	2445	9,5
	112	31,1	100	224	299	373	448	1498	1697	1900	2105	2312	2523	2737	9,5
	125,2	34,8	125	250	334	417	501	1612	1827	2046	2268	2493	2720	2952	9,5
	137,1	38,1	150	274	366	457	549	1698	1926	2158	2392	2631	2873	3118	9,5
	158,4	44	200	317	422	528	633	1824	2070	2320	2574	2831	3093	3358	9,5
2100	92,8	25,8	50	186	247	309	371	1270	1436	1604	1774	1947	2120	2295	10,8
	113,6	31,6	75	227	303	379	455	1516	1716	1919	2124	2332	2542	2755	10,8
	131,2	36,4	100	262	350	437	525	1684	1908	2134	2364	2596	2832	3071	10,8
	146,7	40,8	125	293	391	489	587	1805	2046	2291	2538	2789	3043	3301	10,8
	160,7	44,6	150	321	429	536	643	1897	2152	2409	2670	2935	3204	3476	10,8
	185,6	51,5	200	371	495	619	742	2027	2300	2576	2857	3141	3430	3723	10,8
2400	106,4	29,6	50	213	284	355	426	1412	1597	1784	1973	2163	2356	2549	12,1
	130,3	36,2	75	261	347	434	521	1663	1883	2104	2329	2555	2785	3016	12,1
	150,5	41,8	100	301	401	502	602	1834	2078	2324	2573	2825	3079	3338	12,1
	168,2	46,7	125	336	449	561	673	1958	2219	2483	2750	3020	3295	3573	12,1
	184,3	51,2	150	369	491	614	737	2052	2356	2603	2884	3169	3457	3750	12,1
	212,8	59,1	200	426	567	709	851	2183	2476	2772	3073	3377	3686	4000	12,1
2700	121,2	33,7	50	242	323	404	485	1584	1791	1999	2211	2425	2640	2858	13,5
	148,5	41,2	75	297	396	495	594	1863	2109	2358	2609	2863	3120	3379	13,5
	171,5	47,6	100	343	457	572	686	2047	2319	2593	2870	3152	3436	3724	13,5
	191,7	53,2	125	383	511	639	767	2175	2464	2757	3053	3354	3658	3966	13,5
	210	58,3	150	420	560	700	840	2268	2570	2876	3186	3500	3819	4141	13,5
	242,5	67,4	200	485	647	808	970	2393	2712	3036	3365	3698	4035	4377	13,5
3000	136,1	37,8	50	272	363	454	544	1696	1917	2141	2367	2594	2825	3057	14,7
	166,7	46,3	75	333	444	556	667	1976	2237	2499	2764	3033	3304	3578	14,7
	192,5	53,5	100	385	513	642	770	2166	2451	2741	3034	3329	3629	3932	14,7
	215,2	59,8	125	430	574	717	861	2302	2606	2914	3227	3543	3863	4186	14,7
	235,7	65,5	150	471	629	786	943	2403	2722	3044	3372	3702	4038	4378	14,7
	272,2	75,6	200	544	726	907	1089	2543	2881	3224	3571	3924	4281	4641	14,7

V_{Wn} = 0.0416 l/s corresponds to 150 l/h

Ceiling induction diffuser DISA-601

DISA-601-HT -...-C -Heating-

NL (mm)	V		P _s (Pa)	Heating capacity primary air (W)				Heating capacity water (W)							ΔP _w (kPa)
	(m ³ /h)	[l/s]		Δt _{pr} (K)				Δt _{RWV} (K)							
				6	8	10	12	16	18	20	22	24	26	28	
900	33,4	9,3	50	67	89	111	134	445	500	556	611	667	722	778	1,3
	40,9	11,4	75	82	109	136	164	547	616	684	752	821	889	958	1,3
	47,2	13,1	100	94	126	157	189	621	699	776	854	931	1009	1087	1,3
	52,8	14,7	125	106	141	176	211	677	762	847	931	1016	1101	1185	1,3
	57,9	16,1	150	116	154	193	231	722	813	903	993	1083	1174	1264	1,3
	66,8	18,6	200	134	178	223	267	790	889	987	1086	1185	1284	1382	1,3
1200	49,5	13,7	50	99	132	165	198	606	681	757	833	909	984	1060	1,6
	60,6	16,8	75	121	162	202	242	738	830	922	1014	1106	1199	1291	1,6
	70	19,4	100	140	187	233	280	830	934	1037	1141	1245	1348	1452	1,6
	78,2	21,7	125	156	209	261	313	899	1011	1123	1236	1348	1460	1573	1,6
	85,7	23,8	150	171	229	286	343	953	1072	1191	1310	1429	1548	1667	1,6
	99	27,5	200	198	264	330	396	1033	1162	1291	1420	1549	1678	1807	1,6
1500	63,1	17,5	50	126	168	210	252	743	836	929	1022	1115	1207	1300	2
	77,3	21,5	75	155	206	258	309	900	1013	1125	1238	1350	1463	1575	2
	89,2	24,8	100	178	238	297	357	1009	1136	1262	1388	1514	1640	1767	2
	99,8	27,7	125	200	266	333	399	1091	1227	1363	1500	1636	1772	1909	2
	109,3	30,4	150	219	291	364	437	1154	1298	1442	1587	1731	1875	2019	2
	126,2	35,1	200	252	337	421	505	1246	1402	1558	1713	1869	2025	2181	2
1800	79,2	22	50	158	211	264	317	886	997	1108	1219	1330	1440	1551	2,3
	97	26,9	75	194	259	323	388	1062	1195	1327	1460	1593	1726	1858	2,3
	112	31,1	100	224	299	373	448	1184	1332	1480	1628	1776	1924	2071	2,3
	125,2	34,8	125	250	334	417	501	1274	1433	1592	1752	1911	2070	2229	2,3
	137,1	38,1	150	274	366	457	549	1344	1512	1679	1847	2015	2183	2351	2,3
	158,4	44	200	317	422	528	633	1445	1626	1806	1987	2168	2348	2529	2,3
2100	92,8	25,8	50	186	247	309	371	1011	1137	1264	1390	1517	1643	1769	2,3
	113,6	31,6	75	227	303	379	455	1209	1360	1512	1663	1814	1965	2116	2,3
	131,2	36,4	100	262	350	437	525	1344	1512	1680	1848	2016	2184	2352	2,3
	146,7	40,8	125	293	391	489	587	1442	1623	1803	1983	2164	2344	2524	2,3
	160,7	44,6	150	321	429	536	643	1517	1707	1896	2086	2276	2465	2655	2,3
	185,6	51,5	200	371	495	619	742	1624	1826	2029	2232	2435	2638	2841	2,3
2400	106,4	29,6	50	213	284	355	426	1138	1281	1423	1565	1708	1850	1992	3
	130,3	36,2	75	261	347	434	521	1347	1515	1684	1852	2021	2189	2357	3
	150,5	41,8	100	301	401	502	602	1490	1676	1862	2048	2235	2421	2607	3
	168,2	46,7	125	336	449	561	673	1594	1793	1992	2192	2391	2590	2789	3
	184,3	51,2	150	369	491	614	737	1674	1883	2092	2301	2510	2719	2929	3
	212,8	59,1	200	426	567	709	851	1787	2011	2234	2458	2681	2904	3128	3
2700	121,2	33,7	50	242	323	404	485	1271	1430	1589	1748	1907	2066	2224	3,3
	148,5	41,2	75	297	396	495	594	1504	1693	1881	2069	2257	2445	2633	3,3
	171,5	47,6	100	343	457	572	686	1658	1865	2072	2279	2487	2694	2901	3,3
	191,7	53,2	125	383	511	639	767	1765	1986	2207	2427	2648	2869	3089	3,3
	210	58,3	150	420	560	700	840	1844	2075	2305	2536	2767	2997	3228	3,3
	242,5	67,4	200	485	647	808	970	1952	2196	2440	2684	2928	3173	3417	3,3
3000	136,1	37,8	50	272	363	454	544	1362	1532	1703	1873	2043	2214	2384	3,6
	166,7	46,3	75	333	444	556	667	1597	1796	1996	2195	2395	2595	2794	3,6
	192,5	53,5	100	385	513	642	770	1755	1975	2194	2414	2633	2853	3072	3,6
	215,2	59,8	125	430	574	717	861	1870	2104	2338	2572	2805	3039	3273	3,6
	235,7	65,5	150	471	629	786	943	1957	2202	2446	2691	2935	3180	3425	3,6
	272,2	75,6	200	544	726	907	1089	2079	2339	2599	2858	3118	3378	3638	3,6

V_{Wh} = 0.0416 l/s corresponds to 150 l/h

Ceiling induction diffuser DISA-601

DISA-601-H -...-D -Heating-

NL (mm)	V		P _s (Pa)	Heating capacity primary air (W)				Heating capacity water (W)							Δp _w (kPa)
	(m³/h)	[l/s]		Δt _{pr} (K)				Δt _{RWV} (K)							
				6	8	10	12	16	18	20	22	24	26	28	
900	50,2	13,9	50	100	134	167	201	664	752	842	932	1024	1117	1211	5,6
	61,4	17,1	75	123	164	205	246	798	905	1014	1124	1236	1350	1466	5,6
	71	19,7	100	142	189	237	284	895	1015	1138	1264	1391	1519	1651	5,6
	79,3	22	125	159	212	264	317	969	1101	1235	1371	1510	1651	1794	5,6
	86,9	24,1	150	174	232	290	348	1028	1168	1312	1457	1606	1756	1909	5,6
	100,3	27,9	200	201	268	334	401	1117	1270	1426	1586	1749	1915	2084	5,6
1200	74,3	20,6	50	149	198	248	297	889	1007	1126	1247	1369	1493	1619	6,9
	91	25,3	75	182	243	303	364	1057	1198	1343	1489	1637	1786	1938	6,9
	105,1	29,2	100	210	280	350	420	1178	1338	1499	1663	1830	1999	2170	6,9
	117,5	32,6	125	235	313	392	470	1270	1442	1618	1796	1978	2161	2349	6,9
	128,7	35,8	150	257	343	429	515	1343	1526	1713	1902	2095	2290	2490	6,9
	148,7	41,3	200	297	396	496	595	1452	1650	1853	2059	2269	2483	2700	6,9
1500	94,8	26,3	50	190	253	316	379	1065	1206	1348	1493	1638	1785	1936	8,2
	116,1	32,2	75	232	310	387	464	1256	1423	1593	1765	1939	2117	2296	8,2
	134	37,2	100	268	357	447	536	1390	1576	1765	1958	2152	2351	2551	8,2
	149,8	41,6	125	300	400	499	599	1490	1691	1895	2102	2312	2526	2744	8,2
	164,2	45,6	150	328	438	547	657	1568	1780	1995	2215	2437	2664	2893	8,2
	189,5	52,7	200	379	505	632	758	1682	1911	2144	2380	2620	2865	3113	8,2
1800	118,9	33	50	238	317	396	476	1241	1404	1570	1738	1907	2079	2251	9,5
	145,7	40,5	75	291	388	486	583	1452	1646	1842	2040	2241	2444	2651	9,5
	168,2	46,7	100	336	449	561	673	1600	1814	2031	2251	2474	2701	2931	9,5
	188	52,2	125	376	501	627	752	1709	1939	2171	2408	2648	2891	3138	9,5
	206	57,2	150	412	549	687	824	1793	2034	2279	2529	2782	3039	3299	9,5
	237,9	66,1	200	476	634	793	951	1915	2173	2437	2704	2975	3252	3532	9,5
2100	139,4	38,7	50	279	372	465	557	1429	1617	1807	2000	2195	2392	2591	10,8
	170,7	47,4	75	341	455	569	683	1657	1878	2100	2327	2555	2787	3021	10,8
	197,1	54,8	100	394	526	657	788	1815	2058	2303	2553	2805	3061	3320	10,8
	220,4	61,2	125	441	588	735	881	1931	2190	2452	2718	2989	3263	3540	10,8
	241,4	67,1	150	483	644	805	966	2020	2291	2566	2846	3129	3417	3709	10,8
	278,7	77,4	200	557	743	929	1115	2146	2435	2729	3028	3330	3638	3951	10,8
2400	159,8	44,4	50	320	426	533	639	1585	1794	2005	2218	2433	2651	2871	12,1
	195,7	54,4	75	391	522	652	783	1823	2064	2308	2555	2806	3059	3316	12,1
	226	62,8	100	452	603	753	904	1988	2253	2521	2793	3068	3347	3629	12,1
	252,7	70,2	125	505	674	842	1011	2112	2394	2680	2970	3265	3562	3864	12,1
	276,8	76,9	150	554	738	923	1107	2208	2504	2804	3109	3417	3730	4048	12,1
	319,6	88,8	200	639	852	1065	1278	2350	2665	2985	3311	3642	3977	4316	12,1
2700	182,1	50,6	50	364	486	607	728	1724	1950	2178	2409	2643	2879	3117	13,5
	223	62	75	446	595	743	892	1964	2224	2487	2752	3021	3293	3568	13,5
	257,5	71,5	100	515	687	858	1030	2131	2414	2700	2991	3284	3582	3882	13,5
	287,9	80	125	576	768	960	1152	2255	2555	2859	3166	3479	3795	4115	13,5
	315,4	87,6	150	631	841	1051	1262	2349	2662	2980	3301	3628	3959	4294	13,5
	364,2	101,2	200	728	971	1214	1457	2483	2816	3153	3495	3841	4193	4549	13,5
3000	204,4	56,8	50	409	545	681	818	1841	2082	2326	2572	2821	3072	3326	14,7
	250,4	69,5	75	501	668	835	1001	2110	2388	2670	2955	3243	3533	3828	14,7
	289,1	80,3	100	578	771	964	1156	2292	2595	2902	3213	3527	3846	4169	14,7
	323,2	89,8	125	646	862	1077	1293	2422	2744	3070	3399	3733	4072	4414	14,7
	354	98,3	150	708	944	1180	1416	2519	2855	3195	3539	3888	4241	4600	14,7
	408,8	113,6	200	818	1090	1363	1635	2657	3011	3371	3735	4106	4480	4859	14,7

V_{Wn} = 0.0416 l/s corresponds to 150 l/h

Ceiling induction diffuser DISA-601

DISA-601-HT -...-D -Heating-

NL (mm)	V		P _s (Pa)	Heating capacity primary air (W)				Heating capacity water (W)						ΔP _w (kPa)	
	(m ³ /h)	[l/s]		Δt _{pr} (K)				Δt _{RWV} (K)							
				6	8	10	12	16	18	20	22	24	26	28	
900	50,2	13,9	50	100	134	167	201	511	575	639	703	767	830	894	1,3
	61,4	17,1	75	123	164	205	246	612	688	765	841	918	994	1071	1,3
	71	19,7	100	142	189	237	284	684	770	856	941	1027	1112	1198	1,3
	79,3	22	125	159	212	264	317	740	832	925	1017	1110	1202	1295	1,3
	86,9	24,1	150	174	232	290	348	784	882	980	1078	1176	1274	1372	1,3
	100,3	27,9	200	201	268	334	401	851	957	1064	1170	1277	1383	1489	1,3
1200	74,3	20,6	50	149	198	248	297	688	774	860	946	1032	1118	1204	1,6
	91	25,3	75	182	243	303	364	817	919	1021	1123	1225	1327	1429	1,6
	105,1	29,2	100	210	280	350	420	908	1022	1136	1249	1363	1476	1590	1,6
	117,5	32,6	125	235	313	392	470	978	1101	1223	1345	1468	1590	1712	1,6
	128,7	35,8	150	257	343	429	515	1034	1163	1292	1421	1551	1680	1809	1,6
	148,7	41,3	200	297	396	496	595	1116	1256	1395	1535	1674	1814	1953	1,6
1500	94,8	26,3	50	190	253	316	379	837	942	1046	1151	1255	1360	1465	2
	116,1	32,2	75	232	310	387	464	986	1110	1233	1356	1480	1603	1726	2
	134	37,2	100	268	357	447	536	1091	1228	1364	1501	1637	1773	1910	2
	149,8	41,6	125	300	400	499	599	1170	1316	1462	1609	1755	1901	2047	2
	164,2	45,6	150	328	438	547	657	1231	1385	1539	1693	1847	2001	2155	2
	189,5	52,7	200	379	505	632	758	1322	1487	1652	1818	1983	2148	2313	2
1800	118,9	33	50	238	317	396	476	981	1103	1226	1348	1471	1593	1716	2,3
	145,7	40,5	75	291	388	486	583	1151	1294	1438	1582	1726	1870	2014	2,3
	168,2	46,7	100	336	449	561	673	1269	1427	1586	1745	1903	2062	2220	2,3
	188	52,2	125	376	501	627	752	1356	1526	1695	1865	2035	2204	2374	2,3
	206	57,2	150	412	549	687	824	1424	1602	1780	1958	2136	2314	2492	2,3
	237,9	66,1	200	476	634	793	951	1523	1714	1904	2094	2285	2475	2266	2,3
2100	139,4	38,7	50	279	372	465	557	1130	1272	1413	1554	1695	1837	1978	2,6
	170,7	47,4	75	341	455	569	683	1315	1479	1643	1808	1972	2136	2301	2,6
	197,1	54,8	100	394	526	657	788	1443	1623	1803	1984	2164	2345	2525	2,6
	220,4	61,2	125	441	588	735	881	1538	1730	1922	2114	2307	2499	2691	2,6
	241,4	67,1	150	483	644	805	966	1611	1813	2014	2216	2417	2618	2820	2,6
	278,7	77,4	200	557	743	929	1115	1718	1933	2148	2363	2577	2792	3007	2,6
2400	159,8	44,4	50	320	426	533	639	1263	1421	1578	1736	1894	2052	2210	3
	195,7	54,4	75	391	522	652	783	1456	1638	1820	2002	2184	2366	2548	3
	226	62,8	100	452	603	753	904	1591	1789	1988	2187	2386	2585	2784	3
	252,7	70,2	125	505	674	842	1011	1691	1902	2114	2325	2536	2748	2959	3
	276,8	76,9	150	554	738	923	1107	1768	1990	2211	2432	2653	2874	3095	3
	319,6	88,8	200	639	852	1065	1278	1881	2117	2352	2587	2822	3057	3293	3
2700	182,1	50,6	50	364	486	607	728	1386	1560	1733	1906	2079	2253	2426	3,3
	223	62	75	446	595	743	892	1590	1789	1987	2186	2385	2583	2782	3,3
	257,5	71,5	100	515	687	858	1030	1731	1948	2164	2381	2597	2814	3030	3,3
	287,9	80	125	576	768	960	1152	1836	2066	2295	2525	2755	2984	3214	3,3
	315,4	87,6	150	631	841	1051	1262	1918	2157	2397	2637	2876	3116	3356	3,3
	364,2	101,2	200	728	971	1214	1457	2035	2290	2544	2798	3053	3307	3561	3,3
3000	204,4	56,8	50	409	545	681	818	1487	1673	1858	2044	2230	2416	2602	3,6
	250,4	69,5	75	501	668	835	1001	1712	1926	2140	2354	2568	2782	2996	3,6
	289,1	80,3	100	578	771	964	1156	1864	2097	2330	2563	2796	3029	3262	3,6
	323,2	89,8	125	646	862	1077	1293	1974	2220	2467	2714	2960	3207	3454	3,6
	354	98,3	150	708	944	1180	1416	2056	2313	2570	2827	3084	3342	3599	3,6
	408,8	113,6	200	818	1090	1363	1635	2173	2445	2716	2988	3259	3531	3803	3,6

V_{Wh} = 0.0416 l/s corresponds to 150 l/h

Ceiling induction diffuser DISA-601

DISA-601-H -...-E -Heating-

NL (mm)	V		P _s (Pa)	Heating capacity primary air (W)				Heating capacity water (W)							Δp _w (kPa)
	(m³/h)	[l/s]		Δt _{pr} (K)				Δt _{RWV} (K)							
				6	8	10	12	16	18	20	22	24	26	28	
900	84,8	23,6	50	170	226	283	339	828	939	1052	1167	1284	1403	1522	5,6
	103,9	28,9	75	208	277	346	416	937	1064	1194	1325	1459	1595	1733	5,6
	119,9	33,3	100	240	320	400	480	1015	1153	1294	1438	1584	1732	1883	5,6
	134,1	37,3	125	268	358	447	536	1074	1220	1371	1523	1679	1837	1998	5,6
	146,9	40,8	150	294	392	490	588	1121	1274	1431	1592	1755	1922	2091	5,6
	169,6	47,1	200	339	452	565	679	1193	1357	1526	1698	1873	2051	2234	5,6
1200	125,7	34,9	50	251	335	419	503	1061	1203	1347	1494	1642	1793	1946	6,9
	153,9	42,7	75	308	410	513	616	1190	1350	1514	1679	1847	2018	2192	6,9
	177,7	49,4	100	355	474	592	711	1278	1451	1628	1807	1989	2175	2363	6,9
	198,7	55,2	125	397	530	662	795	1344	1527	1713	1902	2095	2291	2490	6,9
	217,6	60,5	150	435	580	725	871	1395	1586	1780	1977	2178	2382	2590	6,9
	251,3	69,8	200	503	670	838	1005	1473	1675	1881	2090	2304	2521	2742	6,9
1500	160,2	44,5	50	320	427	534	641	1266	1435	1606	1780	1956	2134	2315	8,2
	196,2	54,5	75	392	523	654	785	1416	1605	1798	1994	2193	2395	2599	8,2
	226,6	62,6	100	453	604	755	906	1517	1722	1930	2141	2355	2573	2795	8,2
	253,3	70,4	125	507	675	844	1013	1592	1808	2027	2250	2476	2706	2940	8,2
	277,5	77,1	150	555	740	925	1110	1652	1875	2103	2335	2570	2810	3054	8,2
	320,4	89	200	641	854	1068	1282	1742	1979	2221	2466	2717	2971	3230	8,2
1800	201	55,8	50	402	536	670	804	1440	1632	1826	2022	2221	2423	2627	9,5
	246,2	68,4	75	492	657	821	985	1597	1810	2027	2247	2470	2696	2925	9,5
	284,3	79	100	569	758	948	1137	1704	1933	2165	2401	2640	2882	3129	9,5
	317,9	88,3	125	636	848	1060	1271	1782	2023	2266	2514	2765	3019	3279	9,5
	348,2	96,7	150	696	929	1161	1393	1843	2091	2344	2601	2861	3127	3395	9,5
	402,1	111,7	200	804	1072	1340	1608	1943	2195	2462	2732	3007	3287	3570	9,5
2100	235,6	65,4	50	471	628	785	942	1670	1891	2116	2344	2574	2807	3044	10,8
	288,5	80,2	75	577	769	962	1154	1835	2081	2330	2581	2836	3095	3358	10,8
	333,2	92,5	100	666	888	1111	1333	1947	2207	2472	2740	3012	3289	3568	10,8
	372,5	103,5	125	745	993	1242	1490	2027	2299	2575	2856	3141	3429	3722	10,8
	408,1	113,4	150	816	1088	1360	1632	2090	2371	2656	2946	3240	3539	3843	10,8
	471,2	130,9	200	942	1257	1571	1885	2188	2483	2783	3089	3398	3712	4031	10,8
2400	270,1	75	50	540	720	900	1081	1814	2054	2297	2545	2794	3046	3300	12,1
	330,9	91,9	75	662	882	1103	1323	1990	2255	2523	2796	3071	3350	3633	12,1
	382	106,1	100	764	1019	1273	1528	2108	2389	2673	2963	3256	3553	3855	12,1
	427,1	118,7	125	854	1139	1424	1709	2192	2485	2783	3084	3391	3701	4016	12,1
	467,9	130	150	936	1248	1560	1872	2258	2560	2867	3178	3495	3815	4141	12,1
	540,3	150,1	200	1081	1441	1801	2161	2360	2676	2998	3325	3657	3993	4335	12,1
2700	307,8	85,5	50	616	821	1026	1231	1964	2224	2487	2752	3021	3293	3568	13,5
	377	104,7	75	754	1005	1257	1508	2145	2430	2719	3010	3306	3605	3909	13,5
	435,4	120,9	100	871	1161	1451	1741	2270	2572	2878	3189	3502	3821	4144	13,5
	486,7	135,2	125	973	1298	1622	1947	2361	2677	2997	3320	3648	3981	4318	13,5
	533,2	148,1	150	1066	1422	1777	2133	2433	2759	3088	3423	3762	4105	4454	13,5
	615,7	171	200	1231	1642	2052	2463	2541	2882	3227	3577	3934	4294	4660	13,5
3000	345,5	96	50	691	921	1152	1382	2081	2355	2633	2914	3197	3485	3774	14,7
	423,2	117,6	75	846	1129	1411	1693	2273	2573	2878	3186	3497	3813	4133	14,7
	488,7	135,7	100	977	1303	1629	1955	2399	2718	3040	3367	3697	4032	4371	14,7
	546,3	151,8	125	1093	1457	1821	2185	2490	2822	3157	3497	3841	4190	4543	14,7
	598,5	166,2	150	1197	1596	1995	2394	2560	2901	3246	3597	3952	4312	4676	14,7
	691,1	192	200	1382	1843	2304	2764	2666	3022	3384	3749	4120	4496	4877	14,7

V_{Wn} = 0.0416 l/s corresponds to 150 l/h

Ceiling induction diffuser DISA-601

DISA-601-HT -...-E -Heating-

NL (mm)	V		P _s (Pa)	Heating capacity primary air (W)				Heating capacity water (W)						ΔP _w (kPa)	
	(m ³ /h)	[l/s]		Δt _{pr} (K)				Δt _{RWV} (K)							
				6	8	10	12	16	18	20	22	24	26	28	
900	84,8	23,6	50	170	226	283	339	568	639	709	780	851	922	993	1,3
	103,9	28,9	75	208	277	346	416	646	727	808	889	970	1050	1131	1,3
	119,9	33,3	100	240	320	400	480	703	791	879	967	1055	1143	1231	1,3
	134,1	37,3	125	268	358	447	536	747	840	934	1027	1120	1214	1307	1,3
	146,9	40,8	150	294	392	490	588	782	880	977	1075	1173	1271	1368	1,3
	169,6	47,1	200	339	452	565	679	836	940	1045	1149	1253	1358	1462	1,3
1200	125,7	34,9	50	251	335	419	503	822	925	1027	1130	1233	1336	1438	1,6
	153,9	42,7	75	308	410	513	616	921	1036	1151	1266	1381	1496	1611	1,6
	177,7	49,4	100	355	474	592	711	989	1112	1236	1359	1483	1606	1730	1,6
	198,7	55,2	125	397	530	662	795	1039	1169	1299	1429	1559	1689	1819	1,6
	217,6	60,5	150	435	580	725	871	1079	1214	1349	1484	1619	1754	1889	1,6
	251,3	69,8	200	503	670	838	1005	1141	1284	1426	1569	1712	1854	1997	1,6
1500	160,2	44,5	50	320	427	534	641	988	1112	1235	1359	1482	1606	1729	2
	196,2	54,5	75	392	523	654	785	1104	1242	1380	1518	1656	1794	1932	2
	226,6	62,6	100	453	604	755	906	1182	1330	1478	1625	1773	1921	2069	2
	253,3	70,4	125	507	675	844	1013	1240	1395	1550	1705	1860	2015	2170	2
	277,5	77,1	150	555	740	925	1110	1285	1446	1607	1767	1928	2089	2249	2
	320,4	89	200	641	854	1068	1282	1355	1525	1694	1864	2033	2203	2372	2
1800	201	55,8	50	402	536	670	804	1142	1285	1428	1570	1713	1856	1999	2,3
	246,2	68,4	75	492	657	821	985	1270	1428	1587	1746	1904	2063	2222	2,3
	284,3	79	100	569	758	948	1137	1357	1526	1696	1865	2035	2205	2374	2,3
	317,9	88,3	125	636	848	1060	1271	1421	1599	1776	1954	2131	2309	2487	2,3
	348,2	96,7	150	696	929	1161	1393	1471	1655	1839	2023	2207	2391	2575	2,3
	402,1	111,7	200	804	1072	1340	1608	1548	1742	1936	2129	2323	2516	2710	2,3
2100	235,6	65,4	50	471	628	785	942	1327	1493	1659	1825	1991	2157	2323	2,6
	288,5	80,2	75	577	769	962	1154	1463	1646	1828	2011	2194	2377	2560	2,6
	333,2	92,5	100	666	888	1111	1333	1554	1748	1942	2136	2330	2524	2719	2,6
	372,5	103,5	125	745	993	1242	1490	1620	1823	2026	2228	2431	2633	2836	2,6
	408,1	113,4	150	816	1088	1360	1632	1674	1883	2092	2301	2511	2720	2929	2,6
	471,2	130,9	200	942	1257	1571	1885	1761	1981	2201	2421	2641	2861	3081	2,6
2400	270,1	75	50	540	720	900	1081	1457	1640	1822	2004	2186	2368	2550	3
	330,9	91,9	75	662	882	1103	1323	1605	1805	2006	2206	2407	2607	2808	3
	382	106,1	100	764	1019	1273	1528	1703	1916	2129	2342	2554	2767	2980	3
	427,1	118,7	125	854	1139	1424	1709	1775	1997	2218	2440	2662	2884	3106	3
	467,9	130	150	936	1248	1560	1872	1831	2060	2288	2517	2746	2975	3204	3
	540,3	150,1	200	1081	1441	1801	2161	1918	2158	2397	2637	2877	3117	3356	3
2700	307,8	85,5	50	616	821	1026	1231	1583	1781	1979	2177	2375	2573	2771	3,3
	377	104,7	75	754	1005	1257	1508	1735	1952	2169	2386	2603	2820	3037	3,3
	435,4	120,9	100	871	1161	1451	1741	1839	2069	2299	2529	2759	2989	3218	3,3
	486,7	135,2	125	973	1298	1622	1947	1915	2155	2394	2634	2873	3113	3352	3,3
	533,2	148,1	150	1066	1422	1777	2133	1975	2222	2469	2715	2962	3209	3456	3,3
	615,7	171	200	1231	1642	2052	2463	2065	2323	2581	2839	3097	3355	3614	3,3
3000	345,5	96	50	691	921	1152	1382	1694	1906	2117	2329	2541	2752	2964	3,6
	423,2	117,6	75	846	1129	1411	1693	1857	2089	2321	2554	2786	3018	3250	3,6
	488,7	135,7	100	977	1303	1629	1955	1965	2211	2456	2702	2948	3193	3439	3,6
	546,3	151,8	125	1093	1457	1821	2185	2043	2298	2554	2809	3065	3320	3575	3,6
	598,5	166,2	150	1197	1596	1995	2394	2103	2366	2629	2892	3155	3418	3681	3,6
	691,1	192	200	1382	1843	2304	2764	2197	2471	2746	3021	3295	3570	3844	3,6

V_{Wh} = 0.0416 l/s corresponds to 150 l/h

Ceiling induction diffuser DISA-601

Flow data
DISA-601-...-B-...
Critical throw

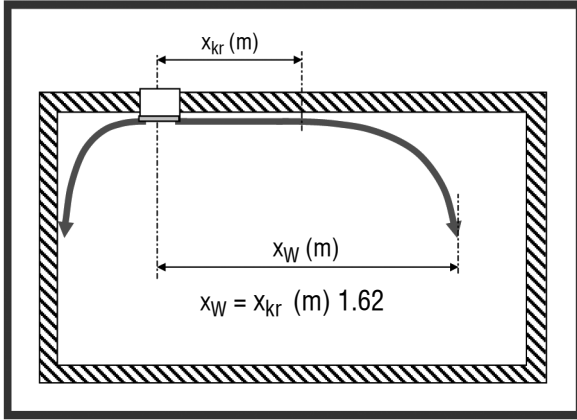

Maximum end velocity of jet (isotherm)
with coanda effect

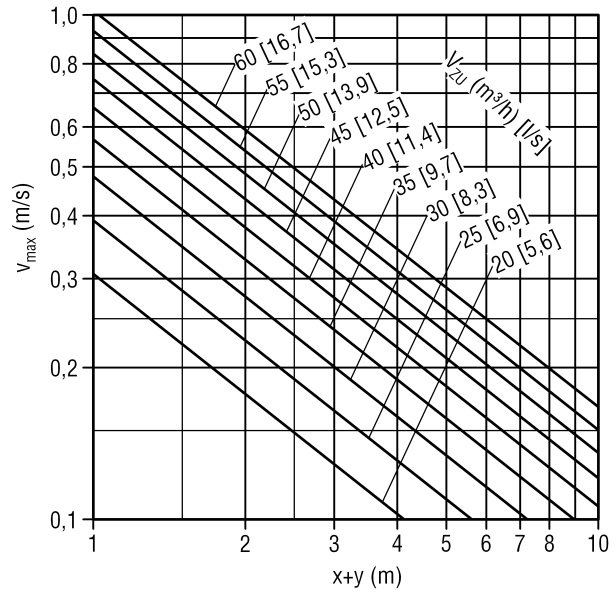
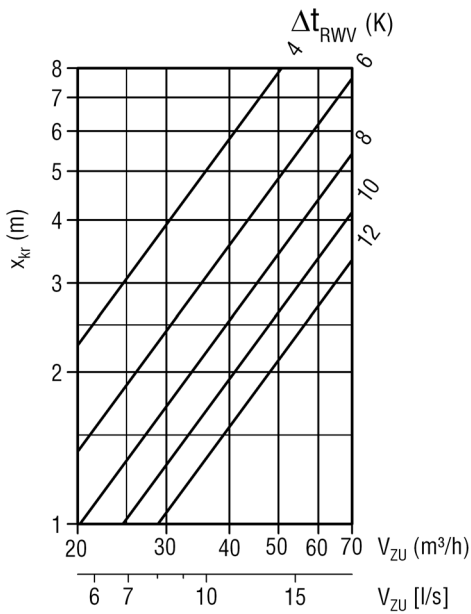
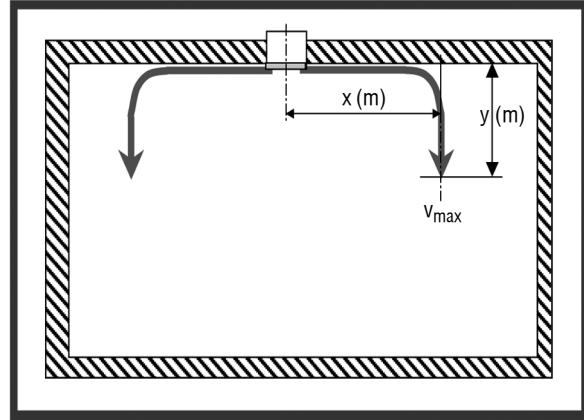

Correction factors for the critical throw

Water Δt_{RWV} (K)	Amount of water [l/h]	Correction factor x critical
6	150	x 0.78
8	150	x 0.72
10	150	x 0.66
6	250	x 0.70
8	250	x 0.65
10	250	x 0.59

$$v_{\text{mittel}} = v_{\text{max}} \times 0.8$$

Length correction factors for air volumes

$V_{ZU} \times KF$

NL	KF
900	x 1.33
1200	x 1.00
1500	x 0.80
1800	x 0.66
2100	x 0.57
2400	x 0.50
2700	x 0.44
3000	x 0.40

Ceiling induction diffuser DISA-601

Maximum end velocity of jet (isotherm) at floor level

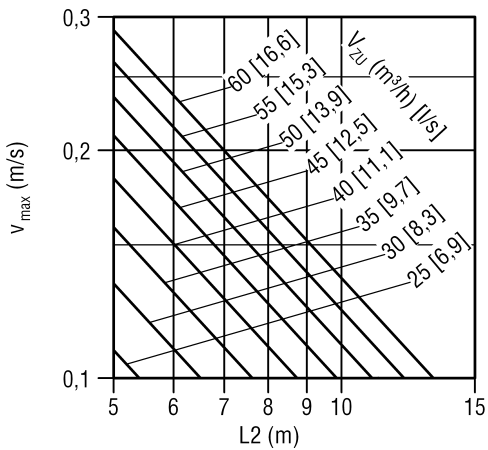
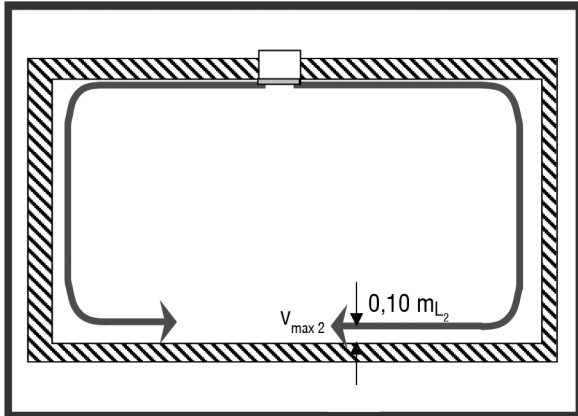

Temperature ratio / induction ratio secondary slot - primary air only

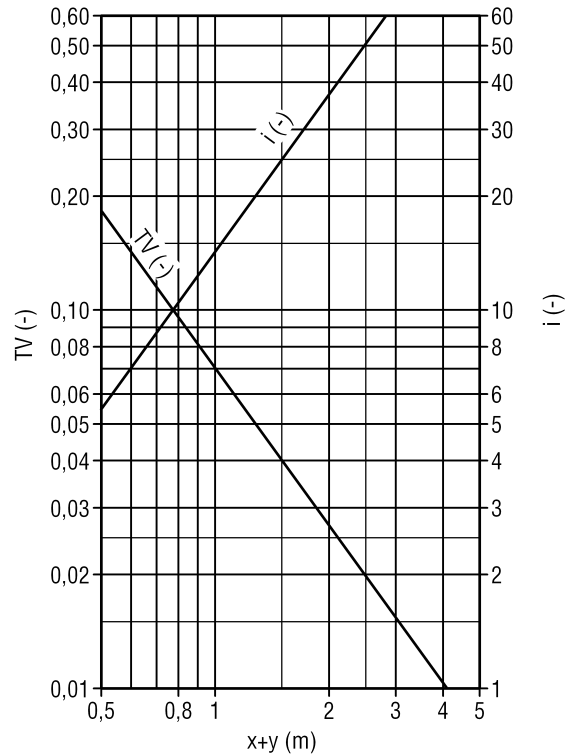

Length correction factors for air volumes

$V_{ZU} \times KF$

NL	KF
900	x 1.33
1200	x 1.00
1500	x 0.80
1800	x 0.66
2100	x 0.57
2400	x 0.50
2700	x 0.44
3000	x 0.40

Ceiling induction diffuser DISA-601

DISA-601-...-C-...

Critical throw

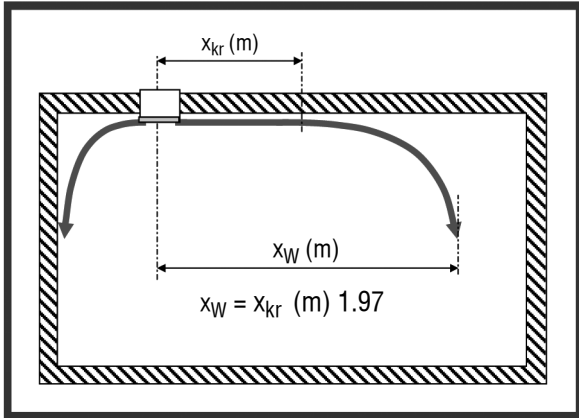

Maximum end velocity of jet (isotherm) with coanda effect

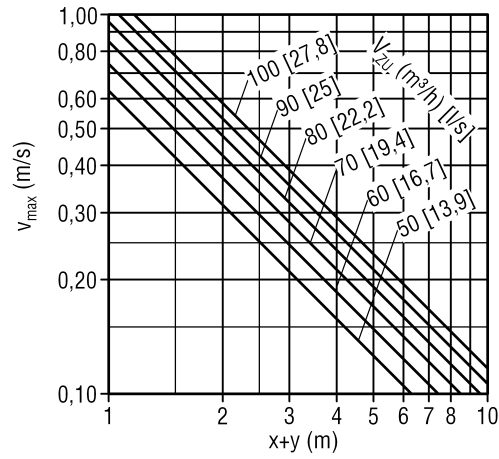
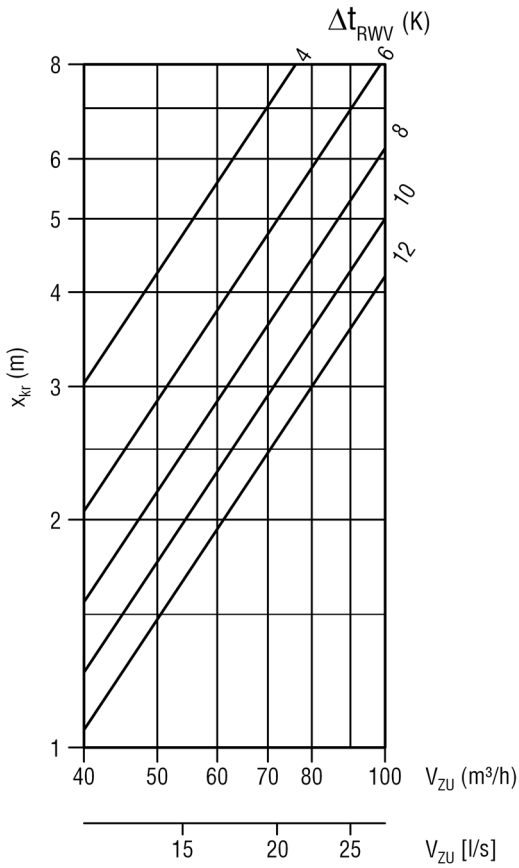
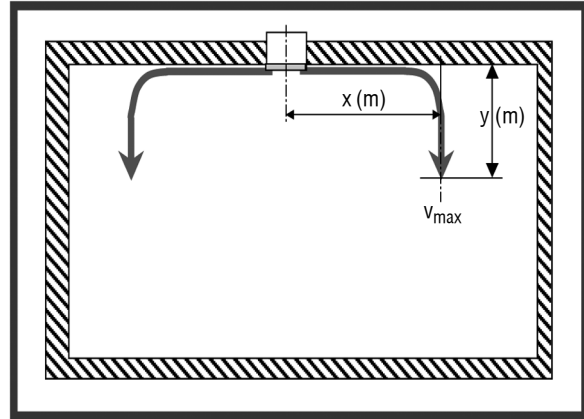

$$v_{\text{mittel}} = v_{\text{max}} \times 0.8$$

Length correction factors for air volumes

$V_{ZU} \times KF$

NL	KF
900	x 1.33
1200	x 1.00
1500	x 0.80
1800	x 0.66
2100	x 0.57
2400	x 0.50
2700	x 0.44
3000	x 0.40

Correction factors for the critical throw

Water Δt_{RWV} (K)	Amount of water [l/h]	Correction factor x critical
6	150	x 0.59
8	150	x 0.57
10	150	x 0.55
6	250	x 0.46
8	250	x 0.44
10	250	x 0.42

Ceiling induction diffuser DISA-601

Maximum end velocity of jet (isotherm) at floor level

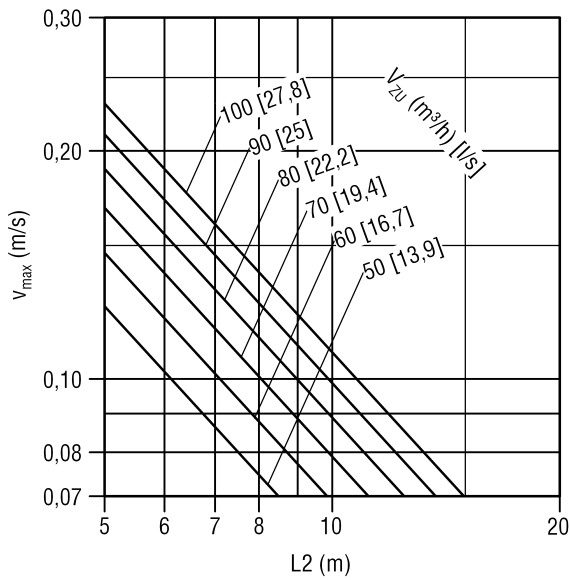
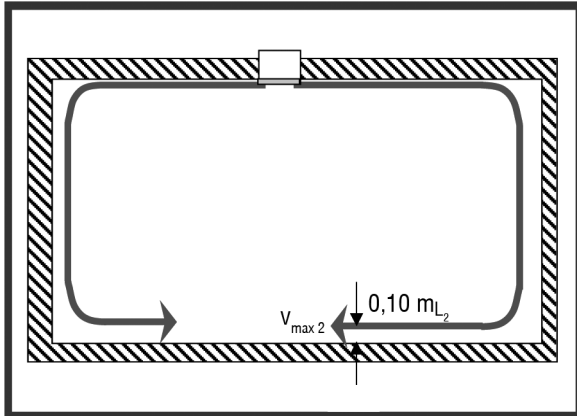

Temperature ratio / induction ratio secondary slot - primary air only

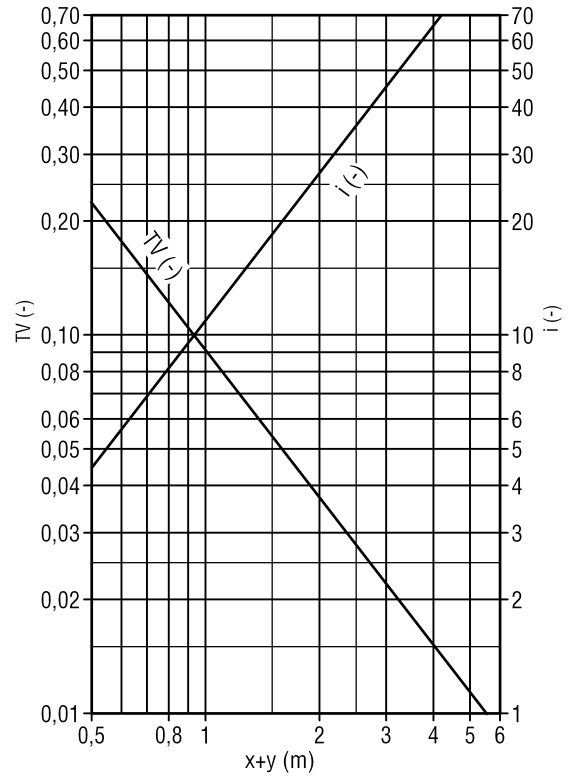

Length correction factors for air volumes

$V_{ZU} \times KF$

NL	KF
900	x 1.33
1200	x 1.00
1500	x 0.80
1800	x 0.66
2100	x 0.57
2400	x 0.50
2700	x 0.44
3000	x 0.40

Ceiling induction diffuser DISA-601

DISA-601-...-D-...

Critical throw

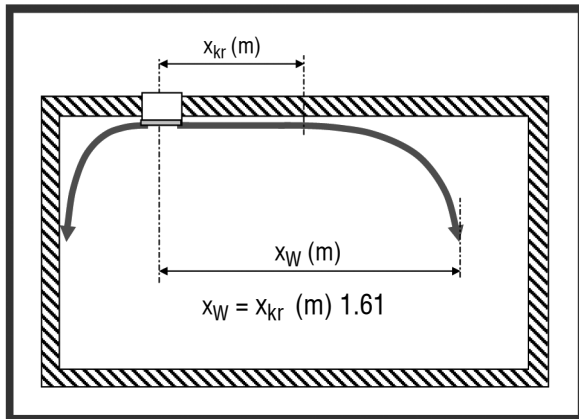

Maximum end velocity of jet (isotherm) with coanda effect

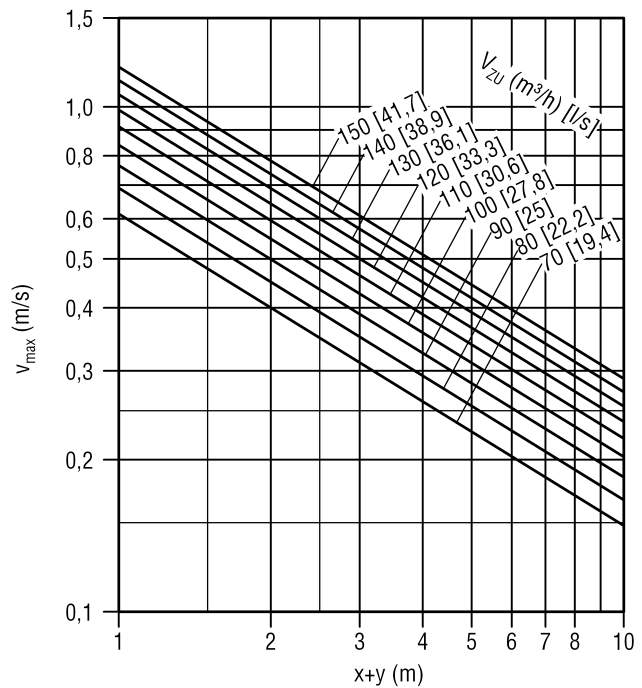
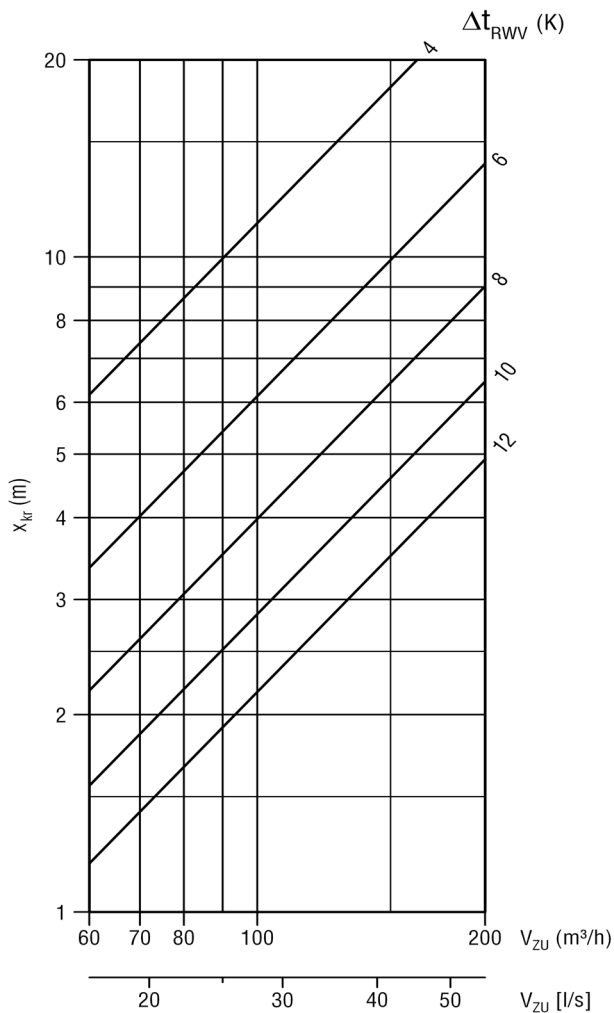
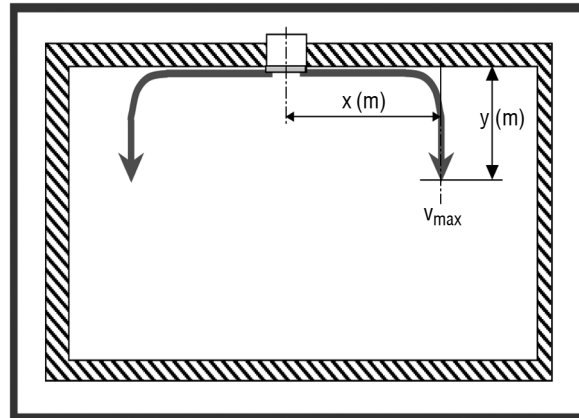

$$v_{\text{mittel}} = v_{\text{max}} \times 0.8$$

Length correction factors for air volumes

$V_{ZU} \times KF$

NL	KF
900	x 1.33
1200	x 1.00
1500	x 0.80
1800	x 0.66
2100	x 0.57
2400	x 0.50
2700	x 0.44
3000	x 0.40

Correction factors for the critical throw

Water Δt_{RvV} (K)	Amount of water [l/h]	Correction factor x critical
6	150	x 0.73
8	150	x 0.61
10	150	x 0.57
6	250	x 0.67
8	250	x 0.57
10	250	x 0.53

Ceiling induction diffuser DISA-601

Maximum end velocity of jet (isothermal) at floor level

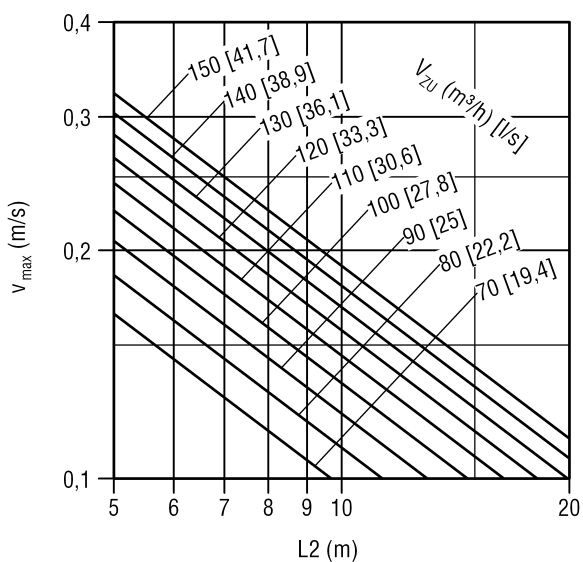
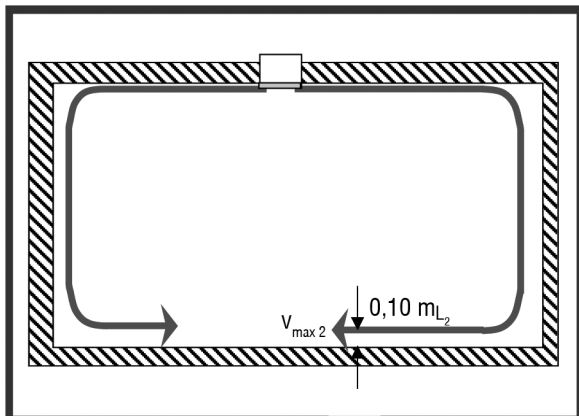

Temperature ratio / induction ratio secondary slot - primary air only

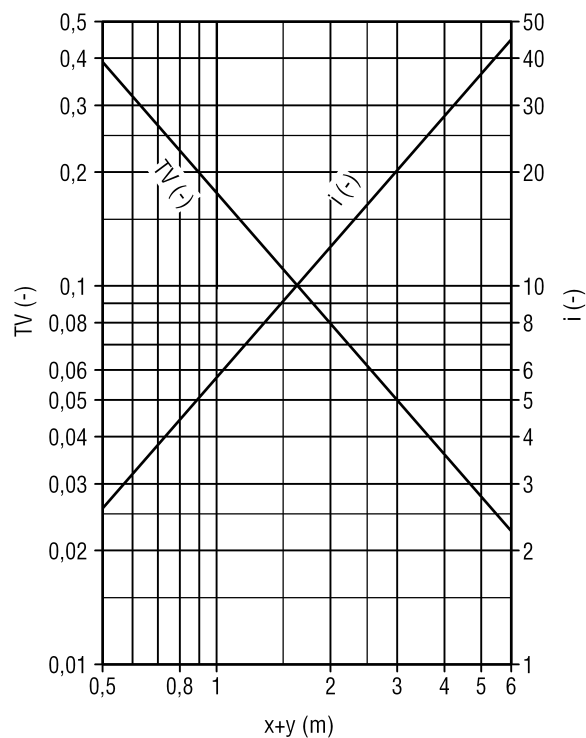

Length correction factors for air volumes

V_{ZU} x KF

NL	KF
900	x 1.33
1200	x 1.00
1500	x 0.80
1800	x 0.66
2100	x 0.57
2400	x 0.50
2700	x 0.44
3000	x 0.40

Ceiling induction diffuser DISA-601

DISA-601-...-E-...

Critical throw

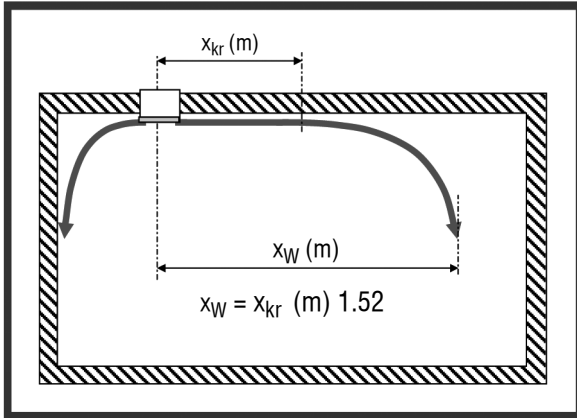

Maximum end velocity of jet (isotherm) with coanda effect

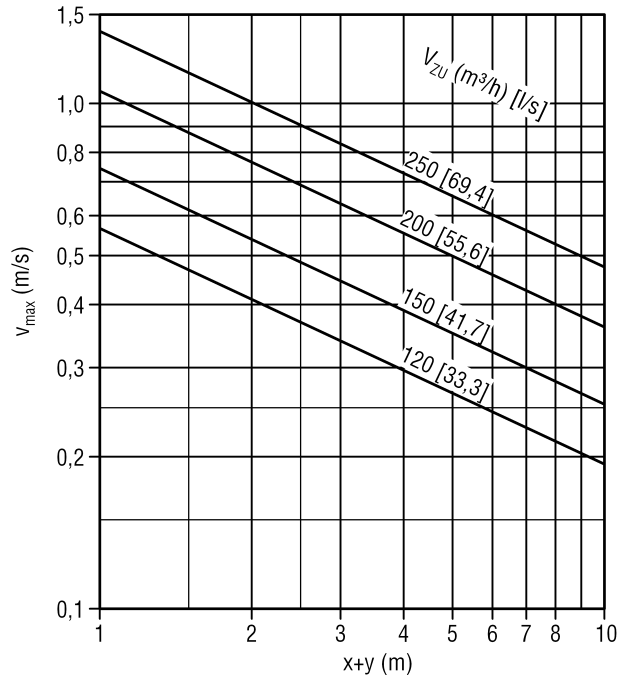
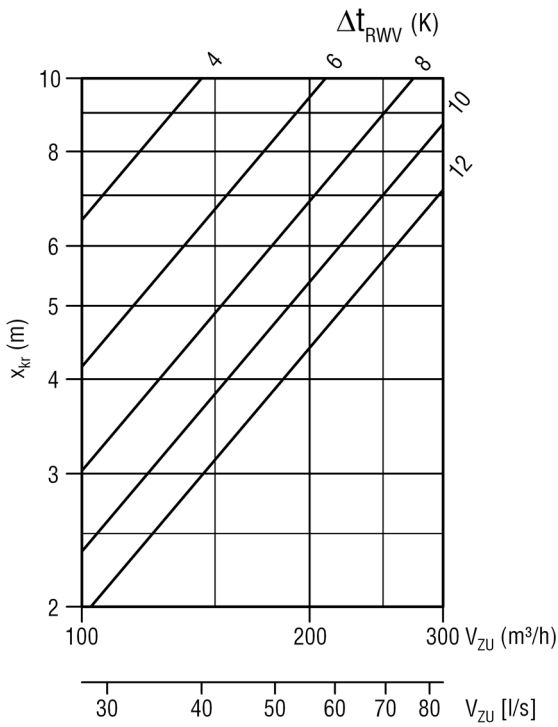
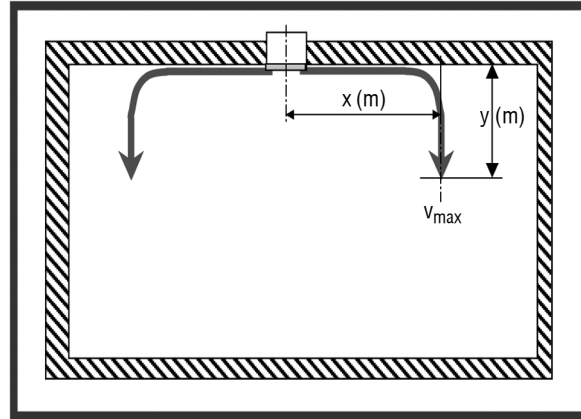

Correction factors for the critical throw

Water Δt_{RWW} (K)	Amount of water [l/h]	Correction factor x critical
6	150	x 0.66
8	150	x 0.63
10	150	x 0.60
6	250	x 0.55
8	250	x 0.53
10	250	x 0.50

$$v_{\text{mittel}} = v_{\text{max}} \times 0.8$$

Length correction factors for air volumes

$V_{ZU} \times KF$

NL	KF
900	x 1.33
1200	x 1.00
1500	x 0.80
1800	x 0.66
2100	x 0.57
2400	x 0.50
2700	x 0.44
3000	x 0.40

Ceiling induction diffuser DISA-601

Maximum end velocity of jet (isotherm) at floor level

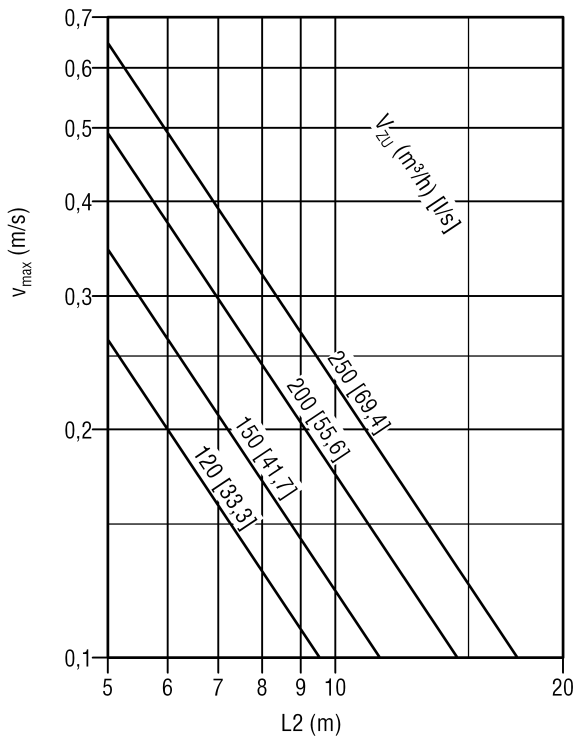
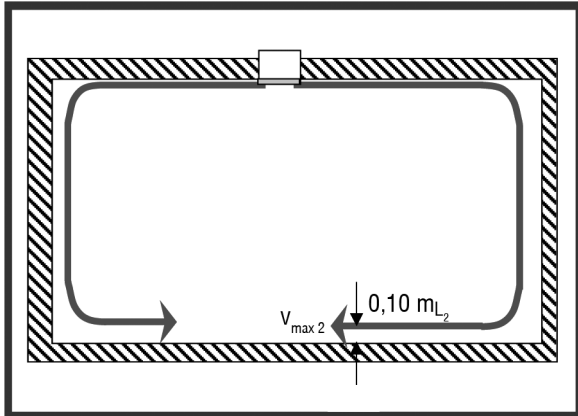

Temperature ratio / induction ratio secondary slot - primary air only

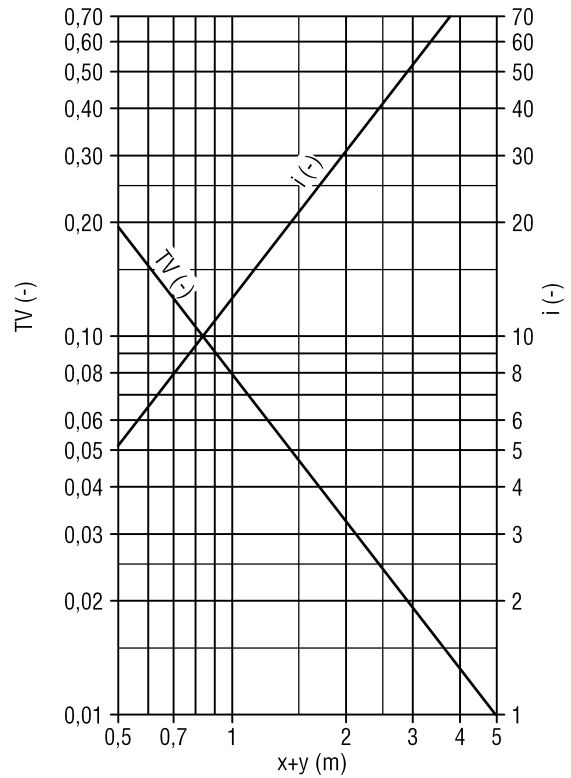

Length correction factor for air volumes

$V_{ZU} \times KF$

NL	KF
900	x 1.33
1200	x 1.00
1500	x 0.80
1800	x 0.66
2100	x 0.57
2400	x 0.50
2700	x 0.44
3000	x 0.40

Ceiling induction diffuser DISA-601

Control units

Valves

3-way valves (series VXP46.10-...)



- Nominal diameter 10 mm
- Connection G1/2 B
- k_{VS} : 0.63 (VXP46.10-0.63) and 1 m³/h (VXP46.10-1)
- Δp_S : 150 kPa
- Δp_{max} : 100 kPa
- Drives SSA (100 N) and STA (100 N)

Compatible drives:

Actuator	Operating voltage	Activation
SSA31	AC 230 V	3-point
SSA61	AC 24 V	DC 0 ...10 V
SSA81	AC 24 V	3-point
STA23	AC 230 V	2-point
STA73	AC 24 V	2-point or PWM ⁽¹⁾
STA63	AC 24 V	DC 0 ...10 V

Selection k_{VS} value

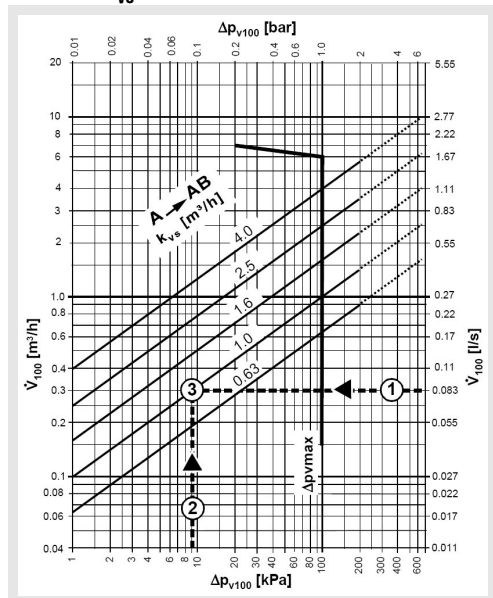

\dot{V}_{100} (m³/h) = (Register) flow rate with fully opened valve
 Δp_{V100} (kPa) = Consumer pressure loss (register)

Operation:

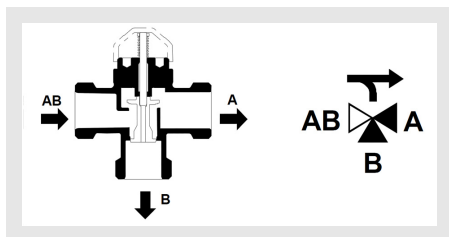

AB → A 0...100%
 AB → B 70...0%

i The 3-way valves VXP46 are designed exclusively as distributor valves. For distributor circuits, the valve must therefore be mounted in the supply line.

2-way valves (series VD115CLC)



- Nominal diameter 15 mm
- Connections inner and outer thread 1/2 inch
- Manual setting button/protective cap included in delivery
- Valve with adjustable k_{VS} by means of a ring 0.25-1.9 m³/h
- Drives SSA (100 N) and STA (100 N)

Compatible drives:

Actuator	Operating voltage	Activation
SSA31	AC 230 V	3-point
SSA61	AC 24 V	DC 0 ...10 V
SSA81	AC 24 V	3-point
STA21	AC 230 V	2-point
STA71	AC 24 V	2-point or PWM ⁽¹⁾
STA63	AC 24 V	DC 0 ...10 V

Valve data:

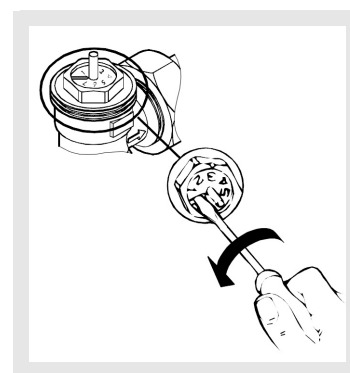

Presetting	Valve stroke (mm)	k_{VS} (m ³ /h)
0 ⁽¹⁾	0	0
1	0,188	0,25
2	0,375	0,65
3	0,563	0,88
4	0,750	1,12
5	0,938	1,30
6	1,125	1,46
7	1,313	1,57
0 ⁽²⁾	1,500	1,90

The presetting < 5 is not recommended because of too little stroke resolution.

- i** Two revolutions are possible on the presetting ring. The values listed in the table (numbers 0¹⁾... 0²⁾) define the first revolution. Another revolution (numbers 0²⁾ ... 6) will increase the stroke to 2.5 mm (completely open), but the k_{VS} values will no longer change after 0²⁾.
- i** If Siemens valves VD...CLC are motorized with actuators SSA61..., the preset flow rate must be fixed at 1.5 mm of valve stroke (factory setting 0²⁾). At a valve stroke < 1.5 mm, self-calibration will not be possible, and the actuator/valve combination will remain blocked.

(1) in connection with room controllers RDG

Ceiling induction diffuser DISA-601

Actuators

Model SSA



- Actuating power 100 N
- Automatic detection of the valve stroke
- Direct mounting
- Manual adjustment and position indicator
- Connecting cable lengths 1.5, 2.5 and 4.5 m

SSA31: actuator 230 V AC, 3-point activation

SSA61: actuator 24 V AC/DC, activation 0...10 V DC

SSA81: actuator 24 V AC, 3-point activation

Connection diagrams:

SSA31:

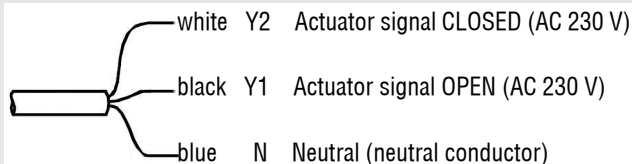

SSA61:

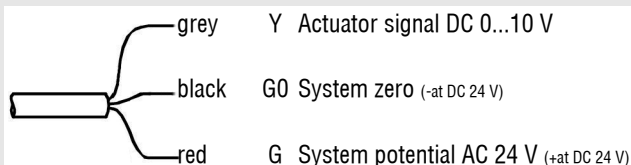

SSA81:

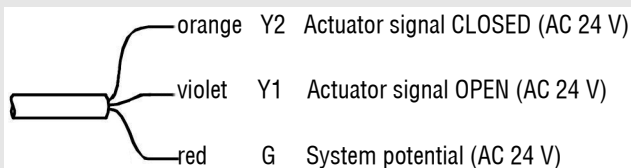

Model STA



- Actuating power 100 N
- Simple installation
- Standard version including 1, 2 or 5 m connecting cables
- Motion and position indicator
- Two-wire connection
- Pulse width modulation (PWM) (room temperature controllers RDG and RCU)

STA23: Operating voltage 230 V AC, actuator signal 2-point

STA73: Operating voltage 24 V AC/DC, actuator signal 2-point or PWM (pulse width modulation)

Connection diagrams:

STA23

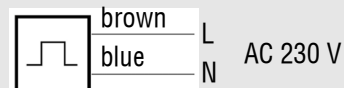

STA73



Model STA63



- Actuating power 100 N
- Simple installation
- Standard version including connecting cables of 1 m. (2, 5 or 7 m optional)
- 270° visible position indication
- 3-wire connection
- Voltage AC 24 V, DC 0...10 V position signal

Connection diagrams:

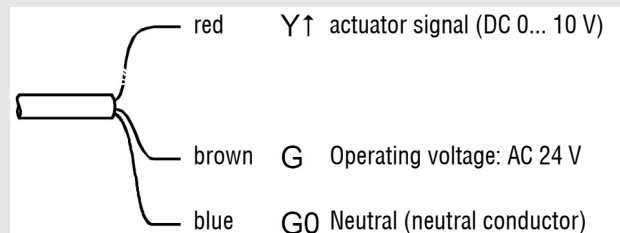

Ceiling induction diffuser DISA-601

Control units

Model RCU 10



- 2-point or steady control with PI behaviour, as desired, combined with model STA
- On/Off or PWM signal
- Operating mode switchover contact input for remote circuit
- Operating voltage AC 230 V

Terminals:

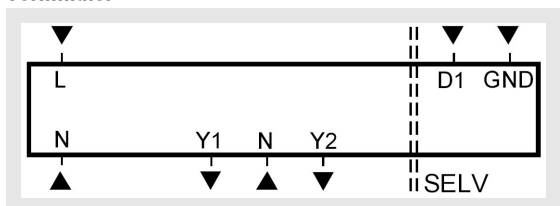

L,N Operating voltage AC 230 V

D1, GND Signal input for potential-free operating mode switch

Y1, Y2 Control signal PWM / 2-point AC 230 V

Connection diagram:

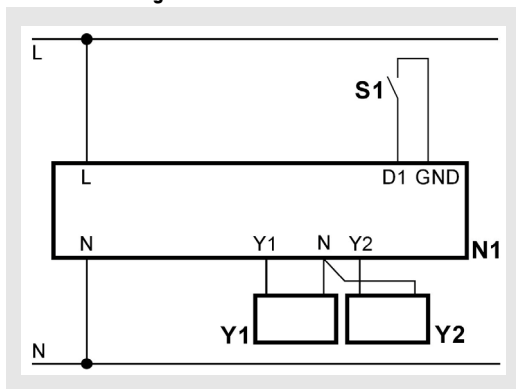

N1 Room temperature control

S1 External operating mode converter

Y1, Y2 Actuator

Model RCU 15



- 2-point or steady control with PI behaviour, as desired
- ON/OFF or PWM actuator signal outputs
- Standard, Economy and Stand-by operating modes
- Operating mode switchover contact input for remote circuit
- Operating voltage AC 24 V

Terminals:

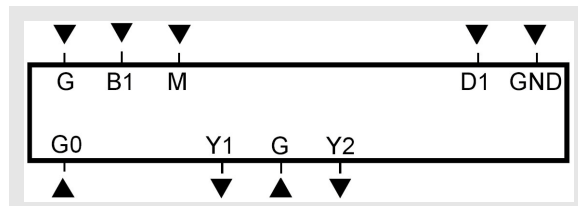

G, G0 Operating voltage AC 24 V

B1 Signal input external room temperature sensor or return air temperature sensor

D1, GND Signal input for potential-free operating mode switch

M Measurement zero "external room temperature sensor or return air temperature sensor"

Y1, Y2 Control signal PWM / 2-point AC 24 V

Connection diagram (4-pipe induction units):

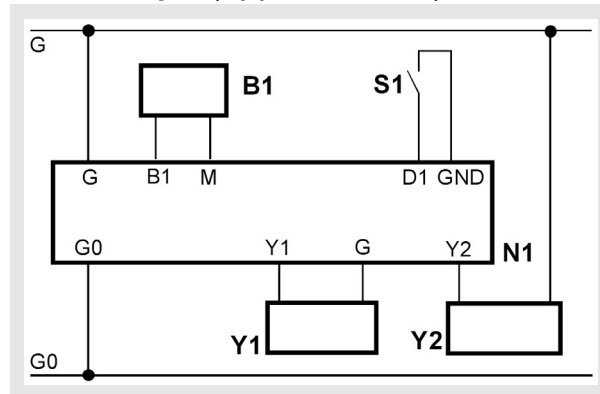

For 2-pipe induction unit, connect only Y1

B1 External room temperature sensor (QAA32) or return air temperature sensor (QAH11.1)

N1 Room temperature control

S1 External operating mode converter

Y1, Y2 Actuator STA71

Ceiling induction diffuser DISA-601

Model RAA41



- Room thermostat with manual switch for heating or cooling
- Two-point control behaviour
- Control voltage AC 24...250 V

Connection diagram:

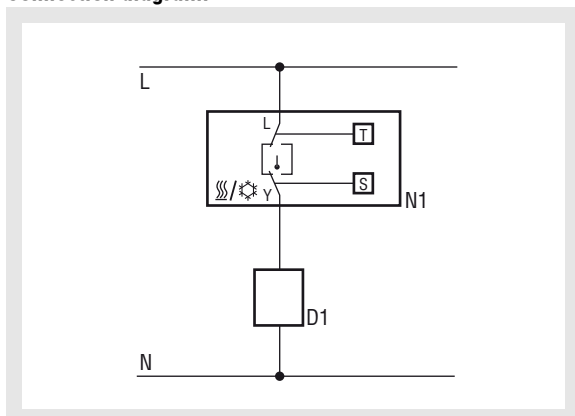

- D1 Zone valves or thermal valves
 L Switching voltage AC 24...250 V
 N1 Room thermostat
 S Selector switch Heating / OFF / Cooling
 Y Control output "Heating" or "Cooling", AC 24...250 V
 N Operating voltage zero
 T Thermocouple (gas membrane)

Model RDG



- Display with backlight
- Automatic switchover between heating and cooling mode via Sensor QAH11.1 (optional)
- Operating modes: Comfort, Economy and Protective modes
- PWM regulation, optional
- Automatic mode with timer program
- Optional RDG KNX communication standard protocol (RDG 100KN)
- Condensation symbol visible on the display (when condensation occurs, the cooling valve will close)

Connection diagram (4-pipe induction units):

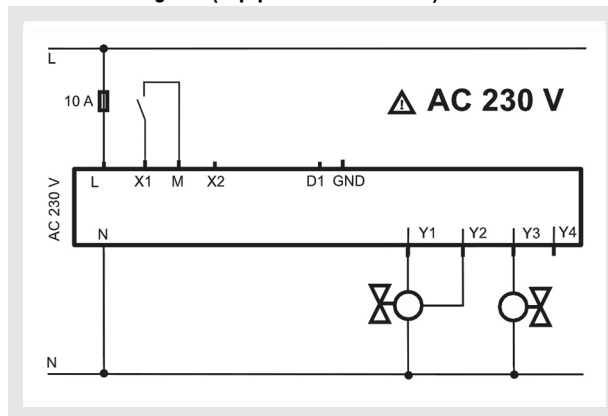

- Y1...Y4 Valve control signal AC 230 V
 L, N Operating voltage AC 230 V
 D1, GND Signal input for potential-free operating mode switch
 X1 Multifunctional input for dew point monitor (e.g. QXA 2000)
 X2 Multifunctional input for temperature sensor (e.g. QAH11.1). Heating / cooling switchover

Ceiling induction diffuser DISA-601

Condensation detector

Models QXA2602 + QXA2604 + QXA2601 and QXA2603



QXA2602
QXA2604



QXA2601
QXA2603

- Operating voltage AC/DC 24 V or AC 230 V
- Potential-free changeover contact AC/DC 1...30V or AC 230V
- Quick and simple installation
- Flat or pre-assembly
- Integrated and remote sensor available
- Status display via two-colour LED

Mode of action:

The condensation detector detects the relative humidity near the dew point (= 100% of r. h.) via its moisture-sensitive element. During this detection, the resistance value of the element increases considerably between 90 ... 100% of r. h. Before reaching the dew point, the electronics of the relay switches. A changeover of the relay contact (two-point output) has the following effect, for example in cooling ceiling applications:

1. The cooling capacity is switched off by the valve position or by a controller until the condensation signal disappears again.
2. The water supply temperature is increased immediately by a selectable value (typically 1 to 2 K) und slowly lowered again once the signal has disappeared. This use results in a specific control function of the controller.

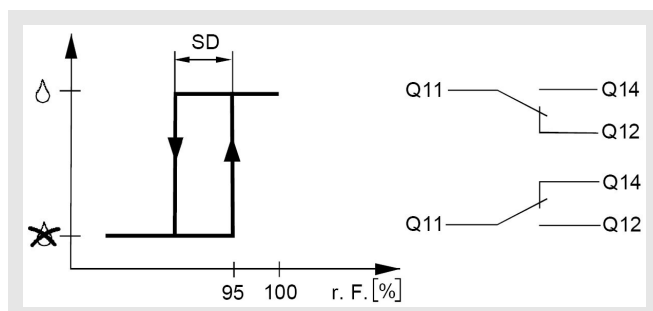

SD Switching difference

Q... Relay contact output

Wiring diagrams: QXA2601 / QXA2602

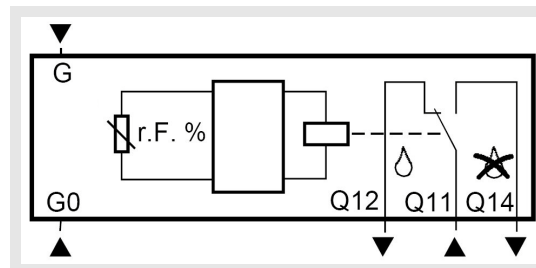

G Measurement voltage AC 24 V (DC 24 V)

G0 System zero

Q... Potential-free changeover contact AC/DC 1...48 V

QXA2603 / QXA2604

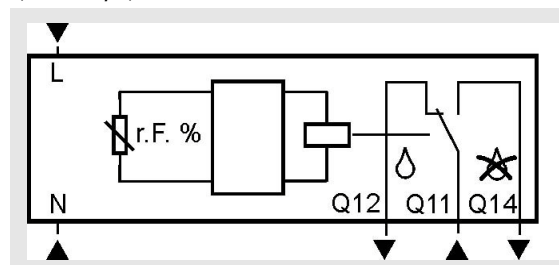

L, N Mains voltage AC 230 V

Q... Potential-free changeover contact AC/DC 12...250 V



A strain relief for the AC 230 V terminals is absolutely necessary. The cables must be attached to the fishplates at the housing base using cable binders (see figure opposite).

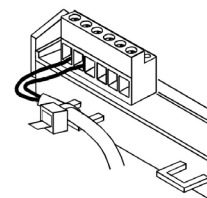

Ceiling induction diffuser DISA-601

Assembly

The induction diffusers are mounted to a load-bearing ceiling construction using threaded bars, nuts and an M8 washer.

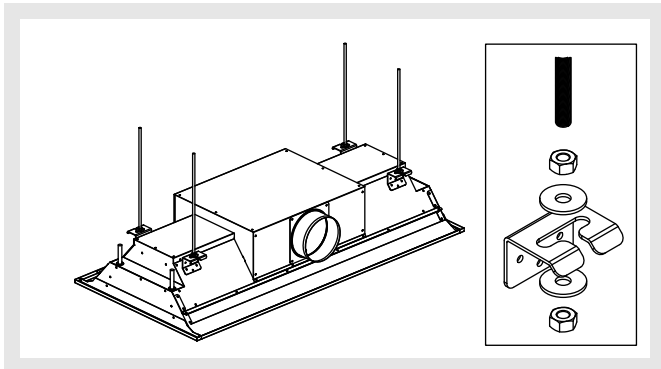

Maintenance

The ceiling induction diffuser DISA-601 is particularly maintenance-friendly. For cleaning the heat exchanger, the secondary air grille can be easily folded down without requiring tools. For cleaning, compressed air or a vacuum cleaner can be used.

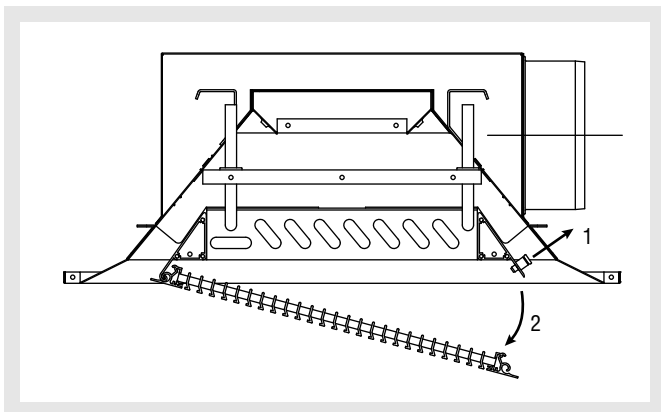
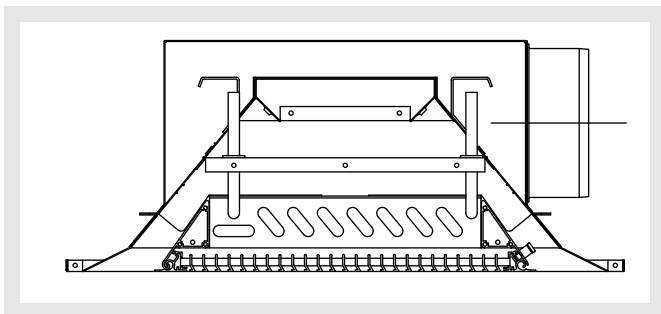

Legend

NL	(mm)	=	Nominal length
LG	(mm)	=	Total length
V	(m ³ /h) [l/s]	=	Primary air flow
V _{Wn}	[l/s]	=	Standard amount of water flow
P _S	(Pa)	=	Static pressure
Δp _W	(kPa)	=	Water-side pressure loss
t _{Pr}	(°C)	=	Primary air temperature
t _R	(°C)	=	Room air temperature
t _{WV}	(°C)	=	Water supply temperature
Δt _{Pr}	(K)	=	Temperature difference between room air and conditioned external air
Δt _{RWV}	(K)	=	Temperature difference between room air and central water supply
L _p	[dB(A)]	=	Sound pressure level (room damping - 8 dB)
v _{max}	(m/s)	=	Maximum end velocity of jet
x+y	(m)	=	Horizontal + vertical throw
x _{kr}	(m)	=	Critical throw
ΔT _x	(K)	=	Temperature difference at point x
V _x	(m ³ /h) [l/s]	=	total air jet volume at point x
i	(-)	=	Induction ratio (i = V _x / V)
TV	(-)	=	Temperature ratio (TV = ΔT _x / Δt _{Pr})
x _w	(m)	=	Throw distance
L ₂	(m)	=	Distance covered by the jet path to the floor level
v _{max2}	(m/s)	=	Maximum end velocity of jet at floor level
k _{vs}	(m ³ /h)	=	Flow characteristic value of the valve in m ³ /h with the valve completely open and a pressure drop of 1 bar
Δp _s	(kPa)	=	Maximum allowed pressure differential at which the valve will still close against the pressure
Δp _{max}	(kPa)	=	Maximum allowed differential pressure above the control path of the valve for the entire actuating range of the valve/actuator unit

Ceiling induction diffuser DISA-601

Ordering details

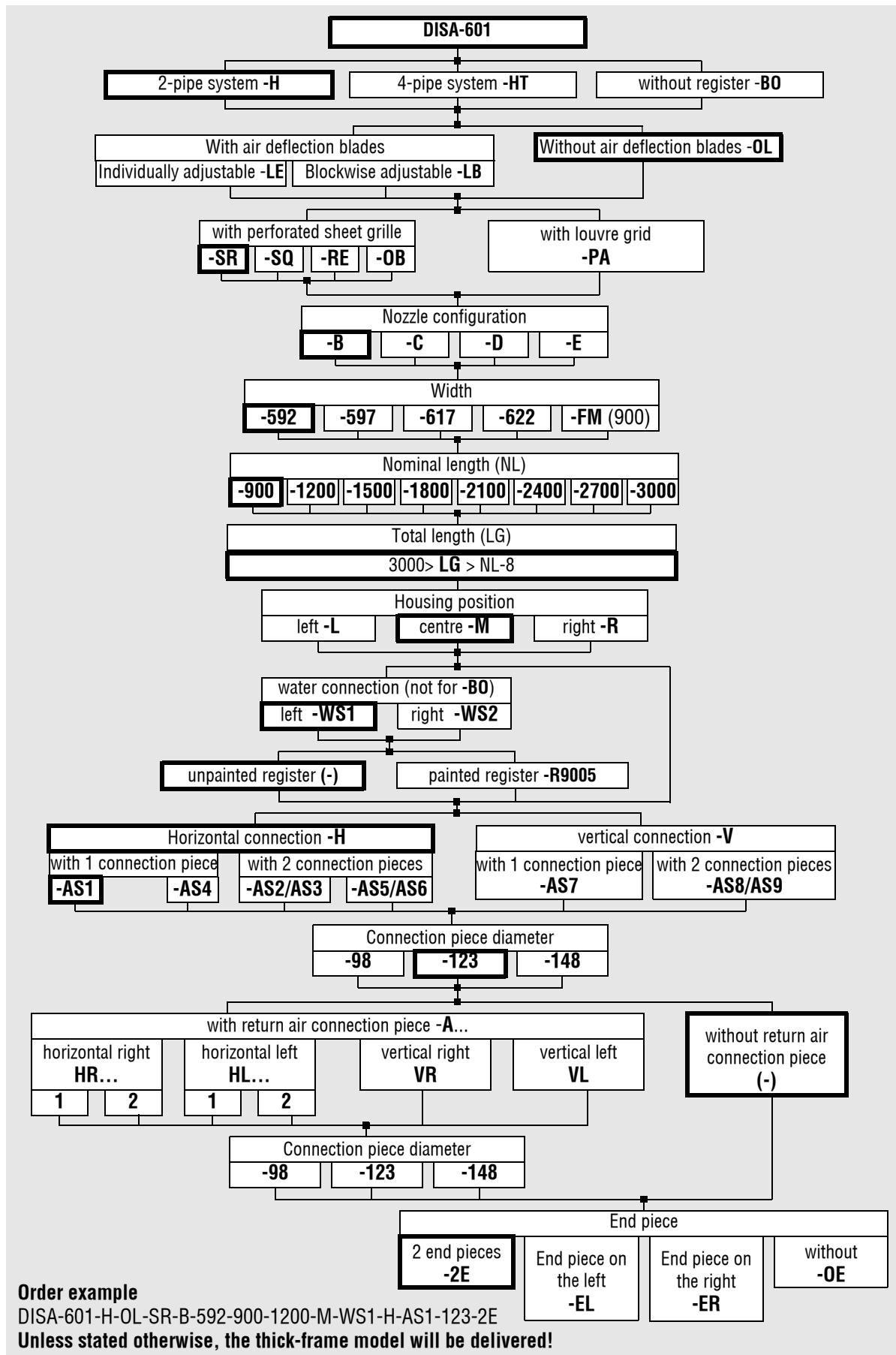

Ceiling induction diffuser DISA-601

Accessories:

Rubber lip seal -GD	Flexible connection hoses -FA (500/800/1200)
Volumetric flow measuring tube -MR	External thread flat-sealing -WA 1/2
Condensation detector	Control units
Valves	Actuators
Band design -BA	

Specification text

Ceiling induction diffuser DISA-601 for installation in false ceilings. 2-slot housing made of galvanised sheet steel. With foldable louvre grid type SCHAKO-PA or perforated sheet made of sheet steel painted to RAL 9010 (white, standard). Horizontal 2-pipe (standard) or 4-pipe register (optional) for cooling and heating, including galvanised sheet steel frame, copper pipes and aluminium blades

Width: 592-900 mm, height: 245 mm, length: 892-3000 mm

Product: SCHAKO type **DISA -601**

- System
 - 2-pipe system (**-H**), standard
 - 4-pipe (**-HT**)
 - without register (**-BO**)
- Air deflection blades
 - Individually adjustable (**-LE**)
 - Blockwise adjustable (**-LB**)
 - Without air deflection blades (**-OL**)
- Perforated sheet grille
 - Foldable perforated sheet, perforation Ø 6 mm (**-SR**, standard)
 - Foldable perforated sheet, perforation 8x8 mm (**-SQ**)
 - Foldable perforated sheet, perforation 12x5 mm (**-RE**)
 - Foldable perforated sheet, oval perforation 20x6 mm (**-OB**)
- Louvre grid (**-PA**)
 - Foldable louvre grid type PA
- Nozzle configuration
 - **B**
 - **C**
 - **D**
 - **E**
- Width
 - **592**
 - **597**
 - **617**
 - **622**
 - **FM (900)**
- Nominal length (NL)
 - **900-3000** (with 300 mm division)

- Total length (LG)
 - 3000 > **LG** > NL-8
- Housing position
 - left (**-L**)
 - centred (**-M**)
 - right (**-R**)
- Water connection
 - sideways top left (**-WS1**)
 - sideways top right (**-WS2**)
- Register paint
 - unpainted register (-)
 - register painted black (**-R9005**)
- Arrangement of connection pieces
 - horizontal with 1 connection piece (**-AS1** or **-AS4**)
 - horizontal with 2 connection pieces (**-AS2/AS3** or **-AS5/**
 - vertical with 1 connection piece (**-AS7**)
 - vertical with 2 connection pieces (**-AS8/AS9**)
- Connection piece diameter
 - Ø **98** mm
 - Ø **123** mm (standard)
 - Ø **148** mm
- Return air connection piece (**-A**)
 - horizontal right (**-HR**)
 - horizontal left (**-HL**)
 - vertical right (**-VR**)
 - vertical left (**-VL**)
- Connection piece diameter of return air connection piece
 - Ø **98** mm
 - Ø **123** mm (Standard)
 - Ø **148** mm
- End piece
 - Model with two end pieces (**-2E**) (standard)
 - Model with left-hand end piece (**-EL**)
 - Model with right-hand end piece (**-ER**)
 - Model without end pieces (**-OE**)

Accessories

- Rubber lip seal (**-GD**)
- Flexible connection hoses
 - 500 mm (**-FA 500**)
 - 800 mm (**-FA 800**)
 - 1200 mm (**-FA 1200**)
- Volumetric flow measuring tube
- External thread flat sealing (**-WA 1/2**)
- Condensation detector
- Control units
- Valves
- Actuators
- Band design (**-BA**)