

Place SP 892T2 profile block upside down on side spindle 2.  
 Place SP 892T1 profile block upside down on side spindle 3.  
 Place 8-15mm adjustable groover on the first top spindle set wider than 7.00mm. Set to produce 7.00mm x 9.00mm deep rebate.

**10mm feed wheel must be fitted at head 3, to run this profile!**

**Wrapping Location**  
**Length of paper wrap 72mm**

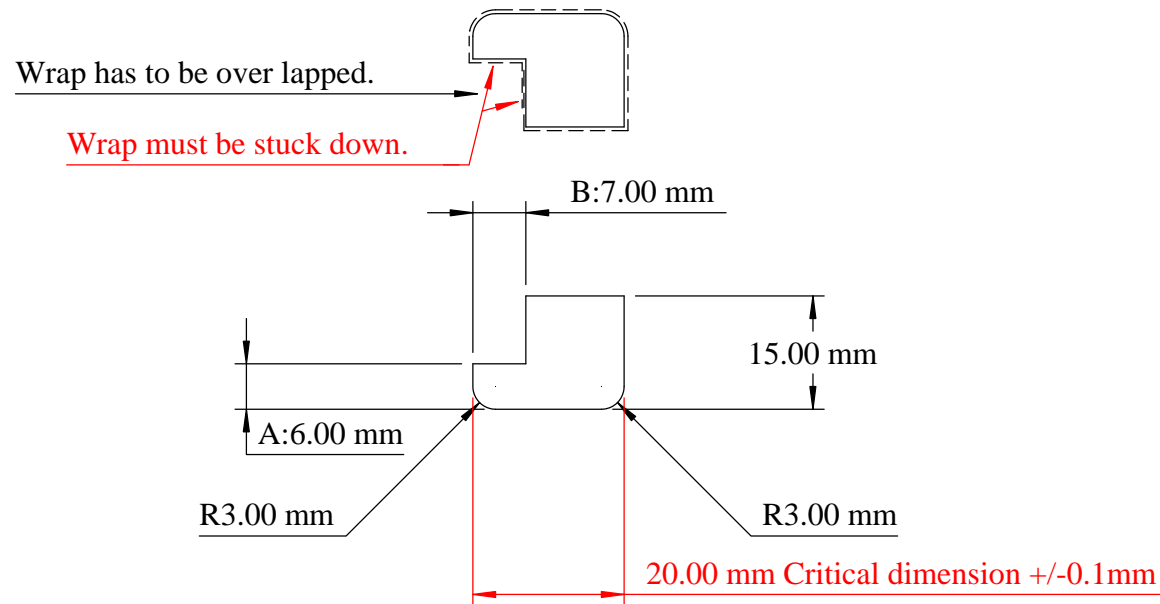

**10mm feed wheel must be fitted at head 3, to run this profile!**

PRINTED COPY UNCONTROLLED

AREA MACHINED AWAY 66.86 SQMM.

MOULDER	ANY
PASSES	1
DRAWN BY	S McMaster
DATE	17/06/12
SCALE	1:1
REV:	2
AUTH:	
TOLERANCE	+/- 0.25MM

**SAM MOULDINGS**

Newpark Industrial Estate Greystone Road Antrim BT41 2RU  
 Tel : (028) 9442 8288 Fax : (028) 9442 8244

Website: [www.sammouldings.co.uk](http://www.sammouldings.co.uk) Email: [info@sammouldings.co.uk](mailto:info@sammouldings.co.uk)

**SAM 3244**