

## Installation Procedure for Fixed Single Pane Flatglass Rooflights

► Flatglass rooflights must be stored and transported flat

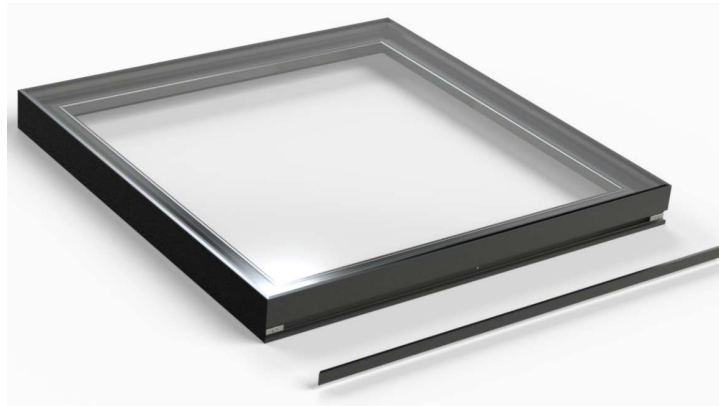

### Tools Required:



Drill



No.25 TX Torx Bit



7mm Drill Bit  
(Supplied)



Rubberised Mallet

### Installation:



Weather Sealant



Kerb Fixing Screws (colour will vary)

## Installation Procedure:

- ▶ 1. Check size of rooflight and the size of the external Kerb to make sure the Rooflight will fit over the kerb. The Rooflight should be bigger than the kerb. The rooflight must not be forced down over the kerb as this will cause the frame to twist which may adversely affect the glass. There should be at least 10mm between inside face of frame and finished kerb. This 10mm is also required for adequate drainage.

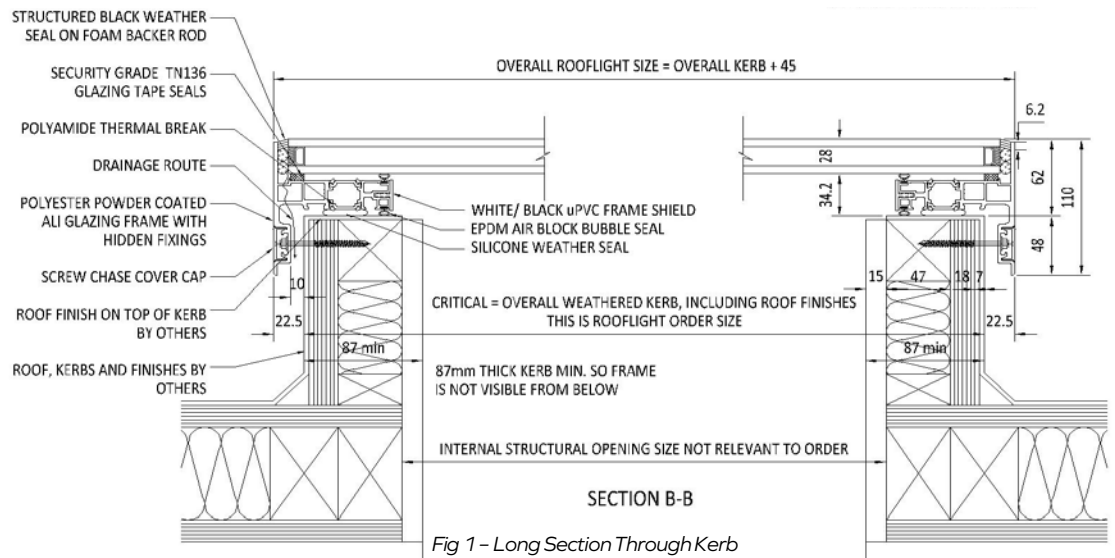

- ▶ 2. Check that the kerb has been constructed with a min 5° fall to help shed water off the glass, and that the kerb top is level and in one continuous plane (this is most important as this could adversely affect drainage).  
5° is a minimum to shed water but this is by no means the correct fall for every rooflight. A decision must be made on site by the installer regarding the correct amount of fall to reduce any water pooling effects.

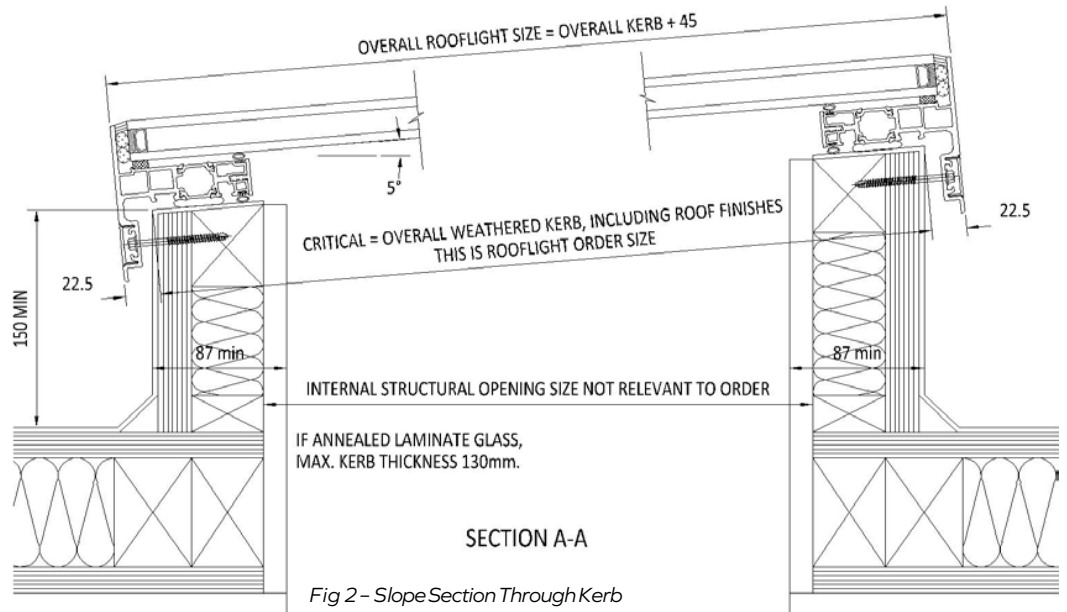

- ▶ **3.** Apply a minimum 30mm wide strip of a one-part, medium-modulus, elastomeric silicone sealant designed for general weather sealing to the top of the kerb to seal and adhere to the underside of the fixing frame. The centre of the 30mm silicone strip should be approx. 30mm from outside kerb face. Alternatively, butyl or foam tape seals can be used.
- ▶ **4.** Position the rooflight onto the top of the kerb ensuring the butyl tape or seal is in full contact with the kerb top around the full perimeter.
- ▶ **5.** Once in place, drill fixing holes in the frame in the lower screw chase with the 7mm drill bit provided. Start 150mm from each corner then at approx. 500mm centres. Use smaller centres for higher wind load areas.
- ▶ **6.** Using the appropriate kerb fixing screws for the kerb material, fix the frame to the kerb horizontally through the fixing holes in the perimeter frame. Make sure to pilot drill the kerb fixing holes with a 3mm drill bit so that the screw heads do not shear off. **DO NOT** overtighten the fixing screws as this will deform the perimeter glazing frame and could cause damage to the glass or result in leaks.

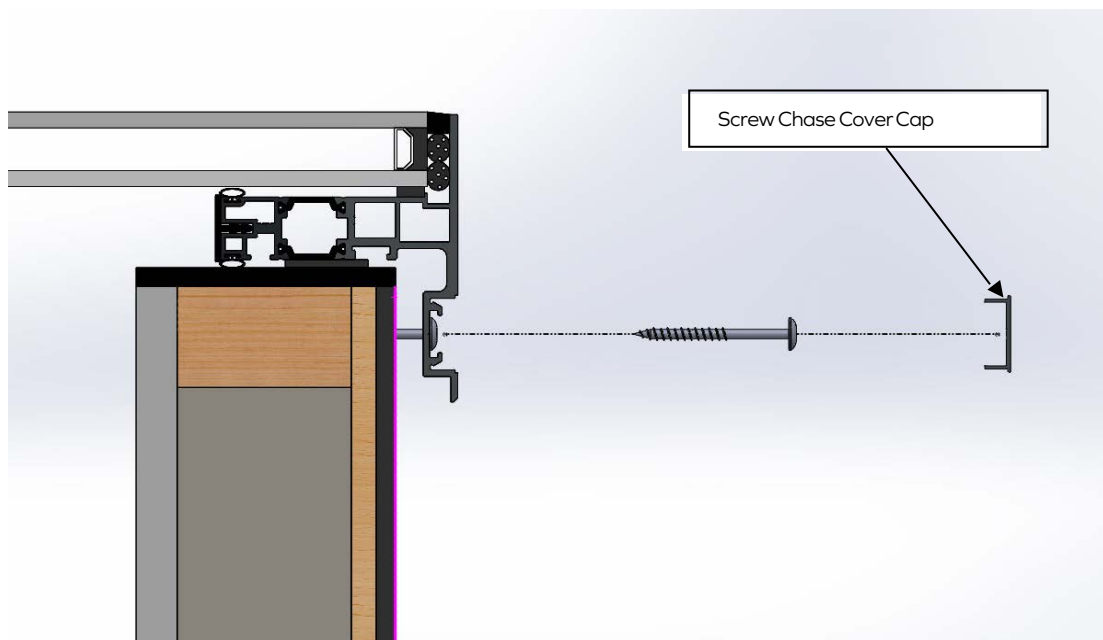

Fig 3 – Kerb Fixing Screw Cover Cap

- ▶ **7.** Once the kerb fixing screws are in place, clip the screw cover cap into place. This may be very tight and hard to clip in. This is to prevent unauthorised access to the screws after installation. Slide three of the cover caps into place and tap the last one in with a large [50mm min.] rubberised mallet. If the cap fitting is loose, use a blob or two of clear silicone or glue under the cap.
- ▶ **8.** PLEASE NOTE: Once the rooflight has been installed all the protective scratch film should be removed on the day of installation. The protective film will become brittle and difficult to remove over time and may damage the frame finish if left for prolonged periods. **DO NOT** leave taped frames in direct sunlight for extended periods.

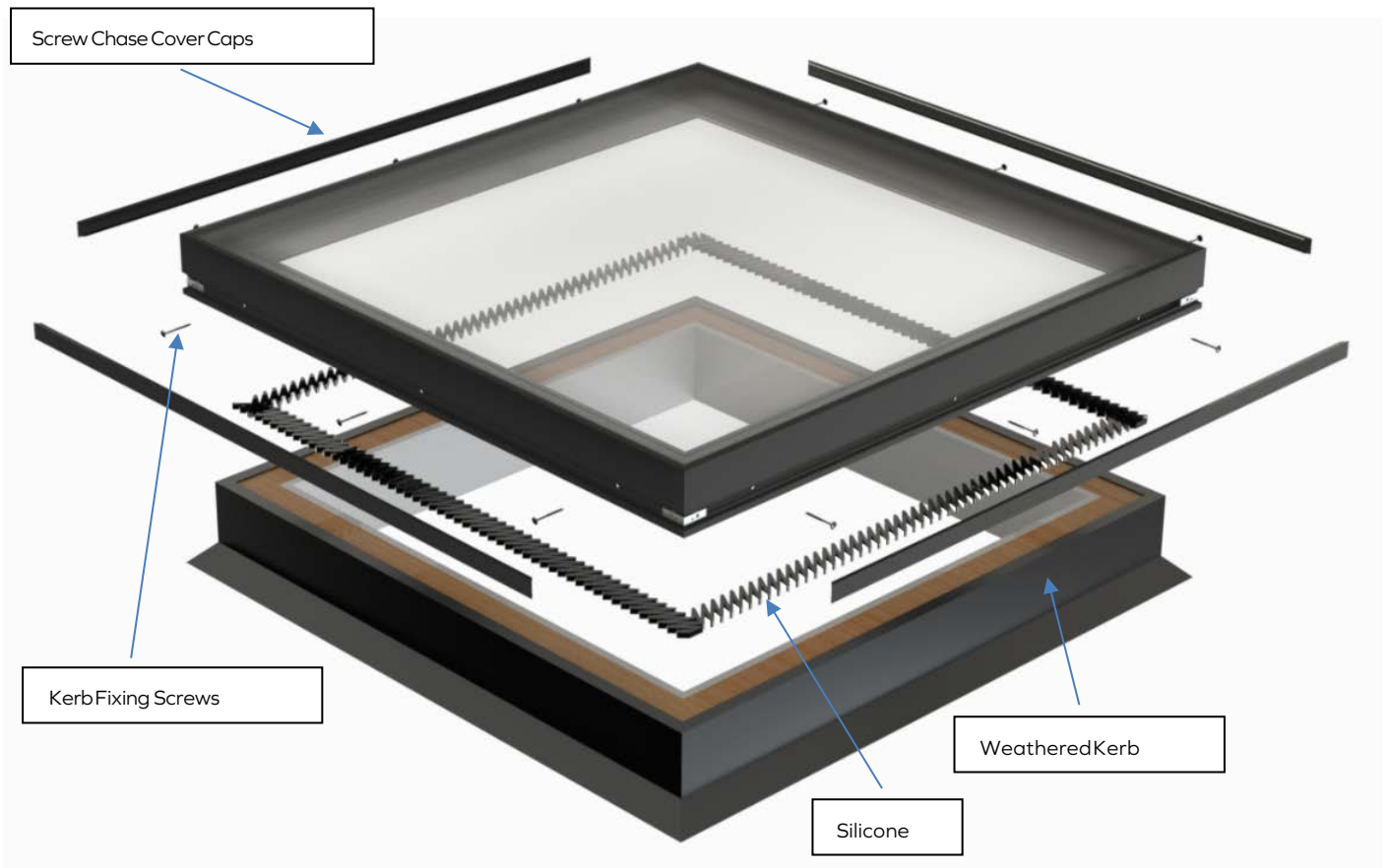

Fig 4 - Exploded Kerb View

## Installation Procedure for Fixed Multi-Pane Flatglass Rooflights



### Installation:



Machine Screws



Kerb Fixing Screws



Weather Sealant



Backer Rod

### Tools Required:



Drill



No. 25 TX Torx Bit

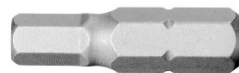

No. 5 Allen Bit



Knife



7mm Drill Bit

## Installation Procedure:

- ▶ 1 Check the size of the rooflight and the size of the external kerb to make sure that the rooflight will fit over the kerb. The rooflight should be bigger than the kerb. The rooflight must not be forced down over the kerb, as this will cause the frame to twist which may adversely affect the glass. There should be at least 10mm between inside face of frame and finished kerb. This 10mm is also required for adequate drainage. See *Figure 1*.
- ▶ 2 Check that the kerb has been constructed with a min 5° fall to help shed water off the glass, and that the kerb top is level and in one continuous plane. (this is most important as this could adversely affect drainage) 5° is a minimum to shed water but this is by no means the correct fall for every rooflight. A decision must be made on site by the installer regarding the correct amount of fall to reduce any water pooling effects. See *Figure 2*.
- ▶ 3 Apply a minimum 30mm wide strip of low modulus weather sealant silicone to the top of the kerb to seal and adhere to the underside of the fixing frame. The centre of the 30mm silicone strip should be approx. 30mm from outside kerb face. Alternatively, butyl or foam tape seals can be used.
- ▶ 4 Depending upon rooflight length, work from one end to the other. Position the Rooflight onto the top of the kerb ensuring the seal is in full contact with both the kerb top and the frame around the full perimeter. If rooflight is too long, start from the middle with a centre section. Measure up and locate it prior to dropping it on the weather seals.
- ▶ 5 Locate the next section of the rooflight and position it next to the first end section, slotting the interlocking glazing bars together if necessary. Line up the central glazing bar holes and screw together using the machine screws supplied. If there are no holes pre-drilled in the glazing bars, no bolts are required.
- ▶ 6 Drill the fixing holes in the frame screw chase with the 7mm drill bit provided.  
Start 150mm from each end and then at approx. 500mm centres. Use closer centres for higher wind load areas.
- ▶ 7 Using the kerb fixing screws supplied, fix the frame to the kerb horizontally through the fixing holes in the perimeter.  
frame. Make sure to pilot drill the kerb fixing holes with a 3mm drill bit so that the stainless-steel screw heads do not shear off. DO NOT overtighten the fixing screws as this will deform the perimeter glazing frame and could cause damage to the glass or cause leaks. See *Figure 3*.
- ▶ 8 Once the kerb fixing screws are in place, clip the screw cover cap into place.  
This may be very tight and hard to clip in. This is to prevent unauthorised access to the screws after installation. Slide three sides of the cover caps into place and tap the last one in with a large [50mm min.] rubberised mallet. If the cap fitting is loose, use a blob or two of clear silicone or glue under the cap.

- ▶ 9 Repeat until all sections are in place.
  
- ▶ 10 Once the glazing bars are bolted together cut the silicone nozzle to approx. 10mm across and run a large bead of silicone along the top of the glazing bars where they meet to create a water-tight seal. You will need a longer than usual nozzle for this.
  
- ▶ 11 Clean the glass. Use masking tape to protect the glass either side of the joint between the glass panes, making sure the tape is fully on the glass edge and not overlapping. See figure 5.
  
- ▶ 12 Cut the foam backer rod to the correct length. Position two lines of the foam backer rod in between the abutting panes of glass. It should be a tight fit so push it down until it is at least 6mm from the top of the glass. .
  
- ▶ 13 Pump silicone into the joint until it just overlaps the height of the glass.
  
- ▶ 13 Pump silicone into the joint until it just overlaps the height of the glass.
  
- ▶ 14 Using a soft, plastic putty scraper or similar, level the silicone into the joint.
  
- ▶ 15 Remove the masking tape and tidy the silicone if required. .
  
- ▶ 16 Snap the uPVC cover shroud into place over the interlocking glazing bars if required. It is designed to hide the internal glazing bars. It will be supplied over length to be measured for fit on site by the installers. It is made from very thin material, so we suggest you use a wedge to support the walls of the shroud when cutting it to the desired length.
  
- ▶ 17 PLEASE NOTE: Once the rooflight has been installed all the protective scratch film should be removed on the day of installation. The protective film will become brittle and difficult to remove over time and may damage the frame finish if left for prolonged periods. DO NOT leave taped frames in direct sunlight for extended periods.

## Glazing Bar Installation Procedure

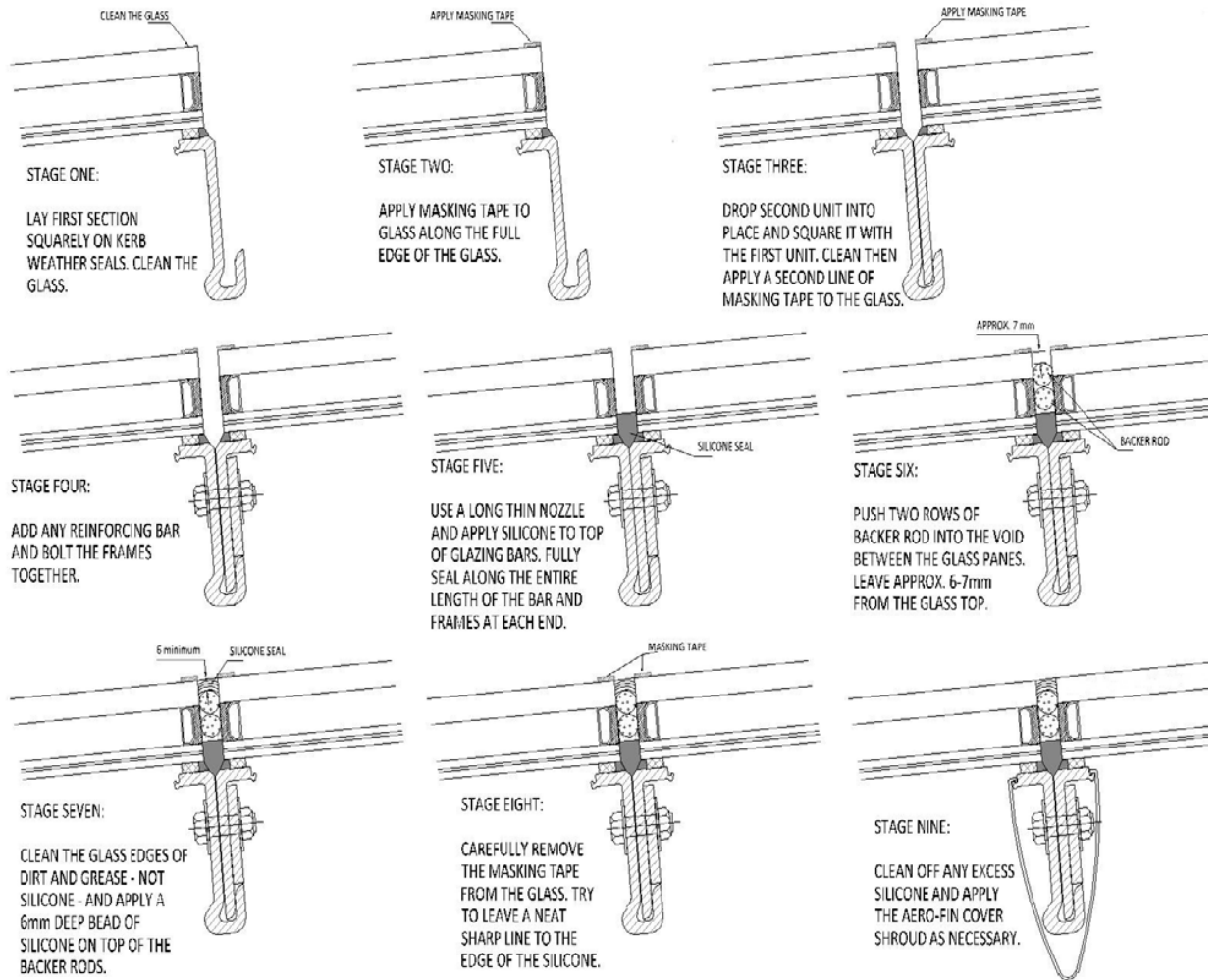

Fig 5- Glazing Bar Installation

## Wall Abutment Detail

If your rooflight has a wall abutment detail you will need to seat the wall abutting plate 5mm away from the wall, on weather sealant which you have already placed on top of the wall plate. The wall plate support is essential. Then provide a silicone seal between the wall and the top of the wall abutment plate. Then screw the rooflight to the wall. Finally, flash over the wall abutment plate with lead or similar, to complete the installation.

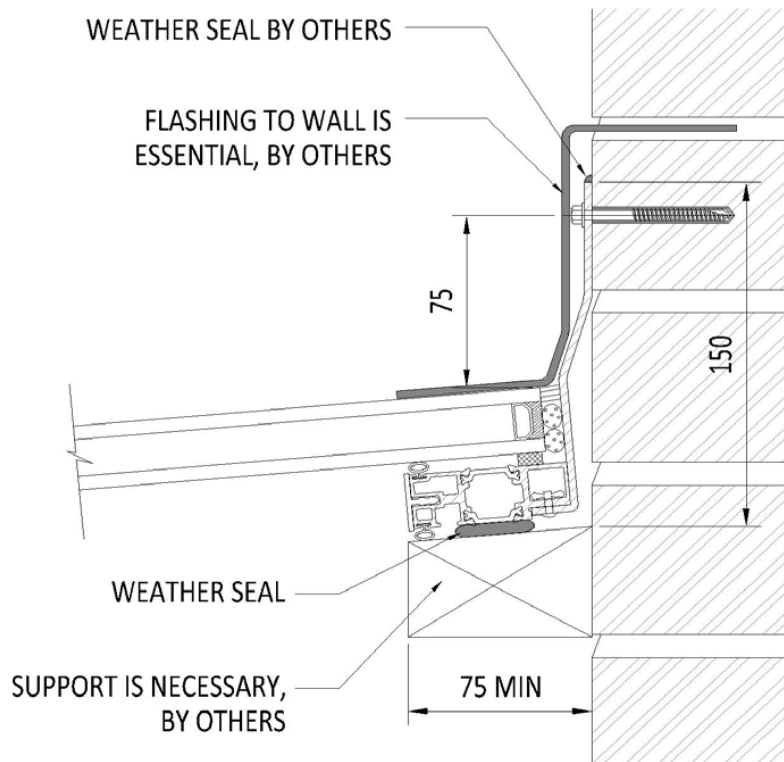

Fig 6 - Wall Abutment Section View

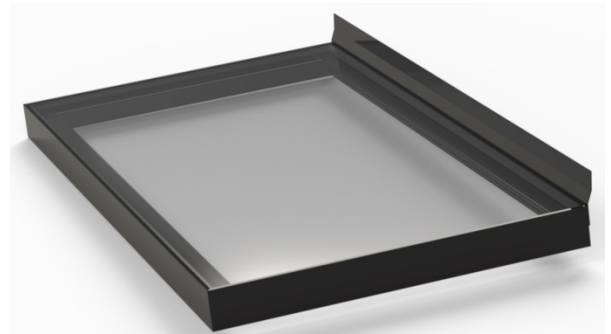

Fig 7 - Wall Abutment Fixed Frame

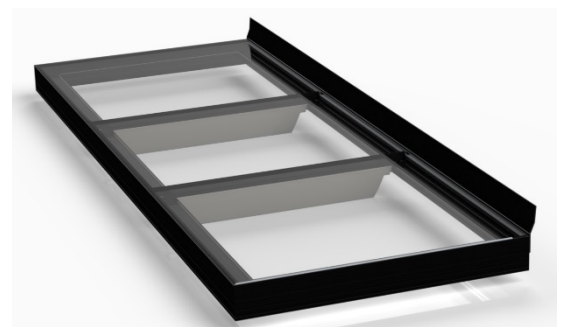

Fig 8 - Wall Multi Section Abutment