

Rockfon® System Eclipse Island™

System Description

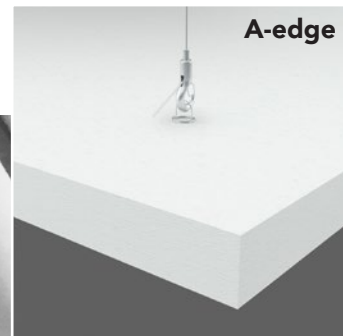

Frameless island system

- Ideal solution for rooms where a suspended ceiling is technically or aesthetically not suitable
- Perfect solution for room acoustic improvement
- Available in different shapes and colours
- Quick and easy installation

Description

Rockfon® System Eclipse Island™ is a frameless acoustic solution available in a variety of geometric shapes. The visible side of Rockfon Eclipse features a minimalistic straight painted A-edge and is covered with a smooth, deep matt, super white painted fleece that has anti-static properties, extending product lifetime. It is also available in bespoke colours. The reverse side of the island is covered with a white acoustic fleece.

Rockfon Eclipse can be suspended under an existing soffit, T24 grid or gypsum ceiling. Using specifically designed accessories, it can be fixed directly to the soffit itself. The Rockfon Eclipse Rectangle, 2360 x 1160 x 40 mm, has two special white aluminum profiles that are integrated to the rear of the island providing extra stability during installation.

This acoustic system is ideal in rooms and buildings where the use of a traditional suspended ceiling is technically not appropriate (e.g. where the principle of thermal mass is incorporated in the building design) or is aesthetically unappealing. It provides a flexible solution for the provision of noise absorption in new constructions and is ideally suited for room acoustic improvements in existing buildings. It is quick and easy to install.

Restrictions

Due to the risk of corrosion, the suspension accessories of Rockfon System Eclipse Island should not be used in swimming pools or outdoor environments. Furthermore, Rockfon System Eclipse Island should not be used in areas subjected to wind load and drafts.



Rockfon spiral anchor is delivered together with a Rockfon Eclipse suspension kit.





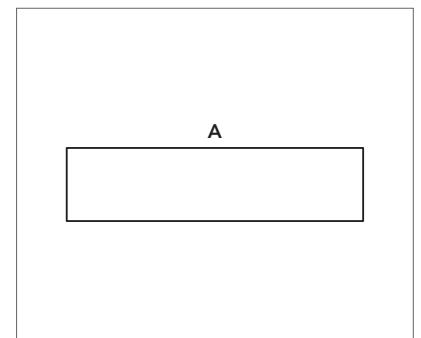



Rockfon can supply two different suspension kits with 1500 mm adjustable metal wire and safe attachment hook.
 1. Classic solution
 2. Design solution

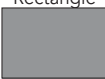

Minimalistic painted straight A edge.

System components

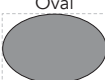
Rockfon Eclipse is available in a variety of geometric shapes:

Rockfon Eclipse			
Shapes	Dimensions (mm)	Weight (kg/unit)	MS* (mm)
 Square	1160 x 1160 x 40	9.0	150 150
 Rectangle	1760 x 1160 x 40 2360 x 1160 x 40**	13.0 17.0	150 150
 Circle	800 x 800 x 40 1160 x 1160 x 40	3.0 7.0	150 150
 Triangle	1160 x 1160 x 40	4.0	150
 Hexagon	1160 x 1160 x 40	6.0	150
 Oval	1760 x 1160 x 40	10.0	150
 Freeform	1760 x 1160 x 40	9.0	150

* MS – Minimum suspension excluding tile.
All rectangle and square Rockfon Eclipse in custom colours are only available in a Be-edge. Size 2360 x 1160 x 40 is only available in custom colours on one side. Contact us for special shapes, colours, sizes, lead times and minimum quantities.

Rockfon Eclipse should be secured with a suspension kit comprising a 1500 mm long adjustable metal wire and a safety attachment hook. Once assembled, the wire is attached to the island by a spiral anchor that is delivered together with the Rockfon Eclipse suspension kit.

We provide two suspension kits; the Classic solution and the Design solution, the latter is relevant for projects where aesthetics are important.

Rockfon Eclipse suspension kits – Classic solution	
Units/box (incl. spiral anchors)	Weight (kg/box)
4 sets of 4	0.91
4 sets of 6	1.40

The Rockfon Eclipse Classic suspension kit can be secured using a standard screw that corresponds to the relevant soffit material (e.g. concrete, wood...).

Rockfon Eclipse suspension kits – Design solution	
Units/box (incl. spiral anchors)	Weight (kg/box)
2 sets of 4	0.44
2 sets of 6	0.80
2 sets of 4 (incl. 2 x 6 spiral anchors)*	0.50

* Suitable packaging concept for Rockfon Eclipse Rectangle 2360 x 1160 mm, when mounted without additional load.

The Rockfon Eclipse Design suspension kit features a refined cylindrical capping that hides the screw thread and provides a visually appealing finish. It can be fastened using a standard screw that corresponds to the relevant soffit material. Alternatively, an M6 threaded fixing can be used.

We only guarantee the integrity of the Rockfon System Eclipse Island if it is installed with Rockfon spiral anchors.

Island - A Edge



Accessories

1. Direct fixing bracket



2. Spiral anchor



3. Suspension kits – Classic solution



4. Suspension kits – Design solution



Performance



System load bearing capacity

The maximum load per spiral anchor is 5 kg. Refer to the Service Integration section for recommendations regarding cutouts, for the integration of lights and similar services.



Corrosion resistance

Due to the risk of corrosion, the suspension accessories of Rockfon System Eclipse Island should not be used in swimming pools or outdoor environments.

Compatible islands

Only Rockfon Eclipse can be used in a Rockfon System Eclipse Island.

Installation

When installing any of the Rockfon System Eclipse shapes, please use the marking tool shown below:

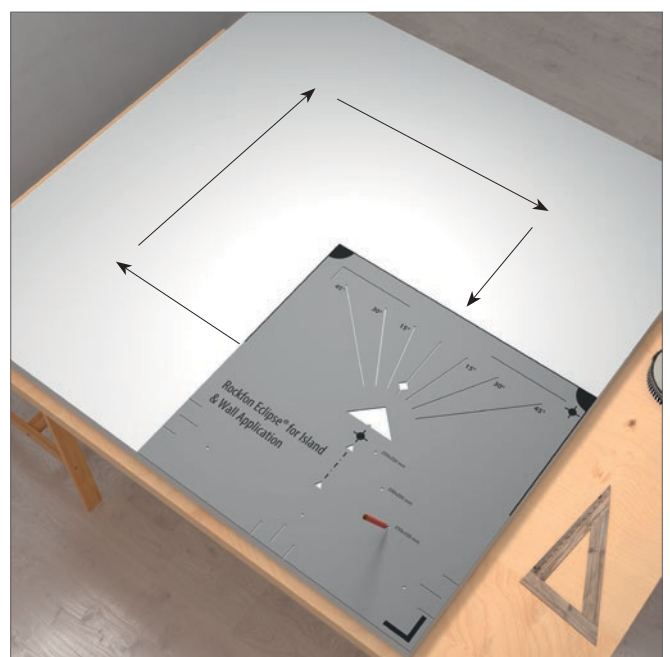
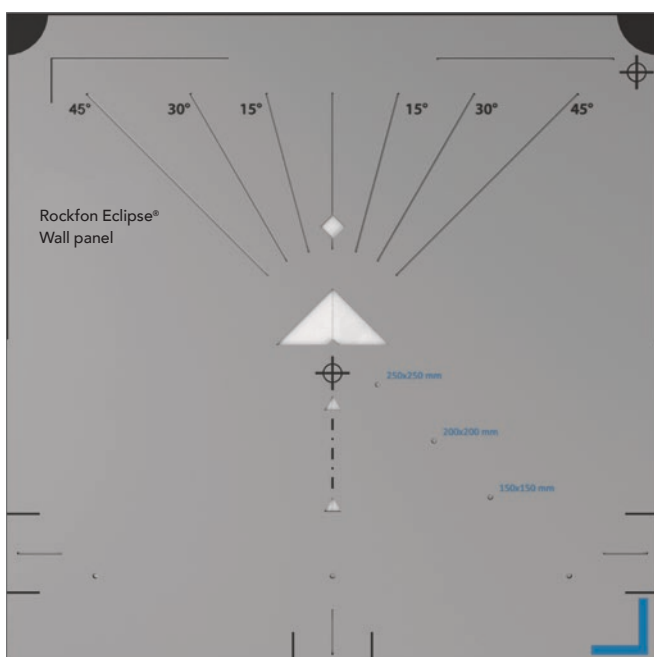

Marking tool.

Black prints are for the Rockfon Eclipse Wall panel.
Blue prints are for the Rockfon Eclipse Island.

Installation

Boxes should be handled with care and by two people. They should be stored in a flat, horizontal position. Each box contains a pair of gloves that should be worn when handling Rockfon Eclipse.

To minimise the risk of damage and for quicker and easier installation, a Rockfon Eclipse island should be handled by two people.

For an optimum work environment, we recommend installers always observe common work practices and follow the installation advice, as shown on our packaging.

Fixing spiral anchors to the island

**Rockfon Eclipse Square 1160 x 1160 mm and
Rockfon Eclipse Rectangle 1760 x 1160 mm**

Spiral anchors need to be screwed vertically into the back of the island at a minimum distance of 150 mm from the edge.

The minimum distance between spiral anchors should be 600 mm. The maximum load per spiral anchor is 5 kg. Four spiral anchors are required for a 1160 x 1160 mm island. In the case of 1760 x 1160 mm islands, six suspension points are required and should be distributed evenly.

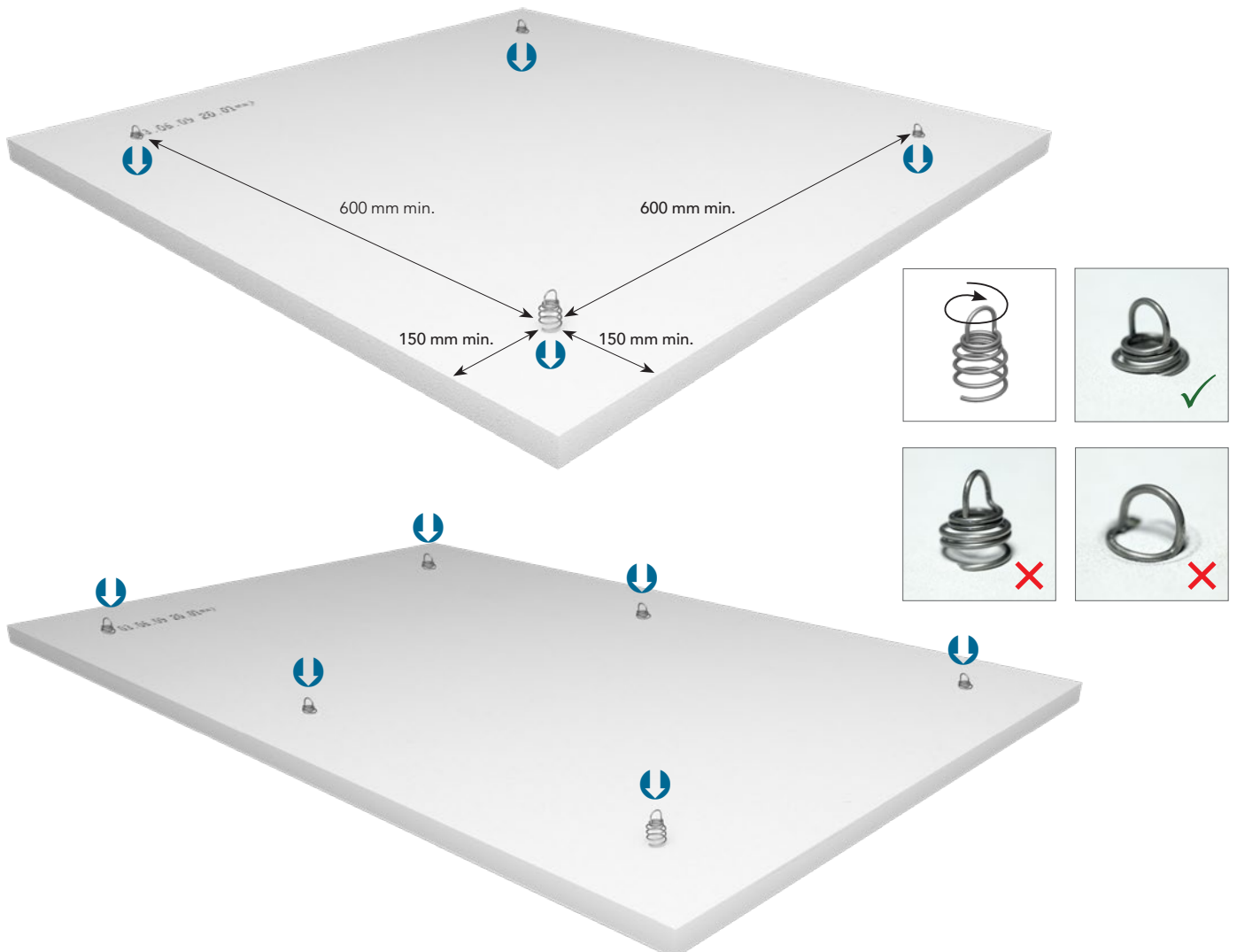

Rockfon Eclipse Rectangle 2360 x 1160 mm

Rockfon Eclipse Rectangular 2360 x 1160 mm is manufactured with two aluminum profiles integrated into the back of the island. Both profiles have five holes where a spiral anchor can be placed. The position of the spiral anchors is dependent on the installation method (described below), but for safety reasons at least six spiral anchors are needed in all situations.

Note: It is highly recommended to install Rockfon Eclipse Rectangle 2360 x 1160 mm level so that the weight is distributed evenly over all suspension points. The use of an installation table can be very helpful!

Installation method 1

When no additional weight is being supported by the island, it can be installed by using only four hanging points (although six spiral anchors must be screwed into the island). **Do not use the outer holes.**

Rockfon Eclipse Rectangle 2360 x 1160 without additional weight: 6 No. spiral anchors, 4 No. suspension hangers.

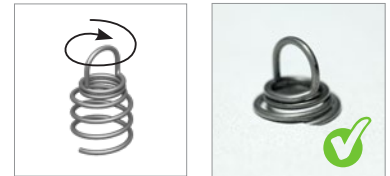
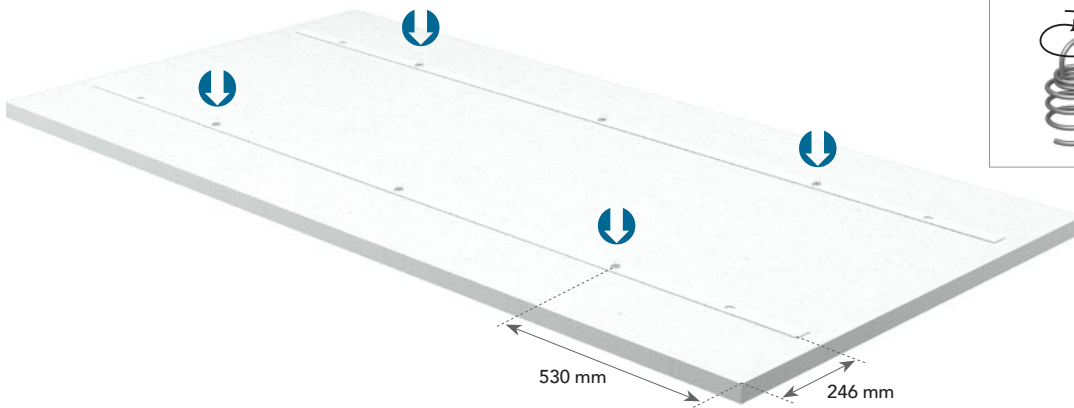

Installation method 2

When additional weight is being supported by the island (max. 5 kg), the island needs to be installed by using six suspension points. **Use the outer holes.**

Rockfon Eclipse Rectangle 2360 x 1160 with additional weight (max. 5 kg): 6 No. spiral anchors, 6 No. suspension hangers.

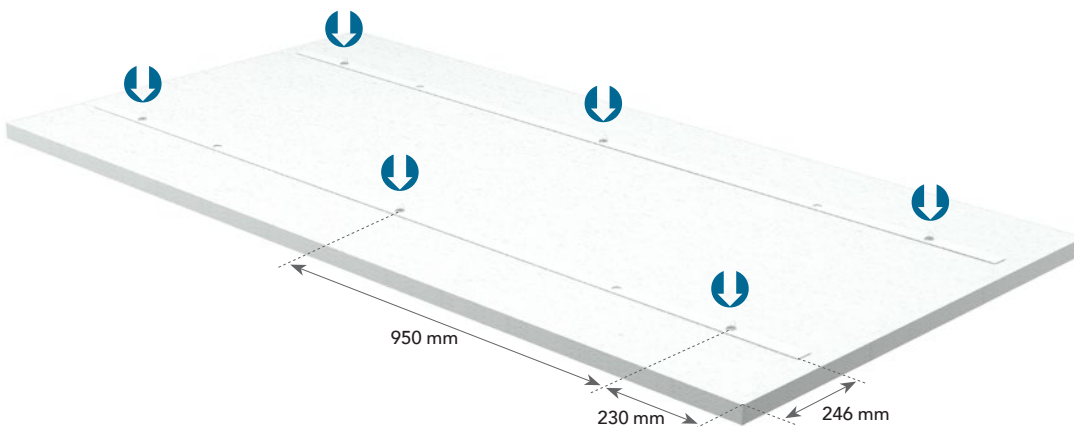

Rockfon Eclipse Shapes

The spiral anchors should be distributed symmetrically as indicated below and at a minimum distance of 100-150 mm from the edge.

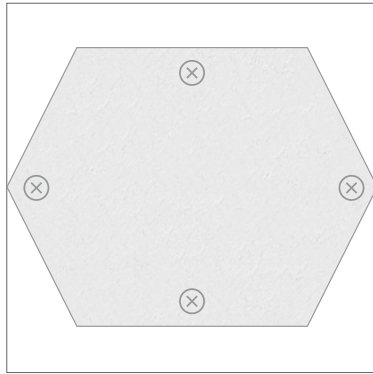
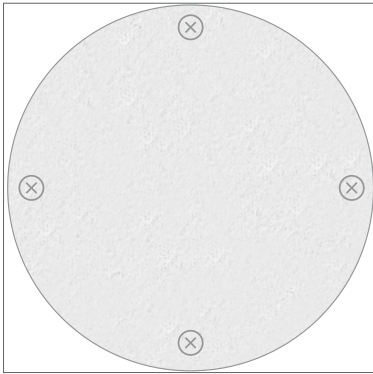

Eclipse circle of 800mm diameter can also be suspended with 3 hangers.

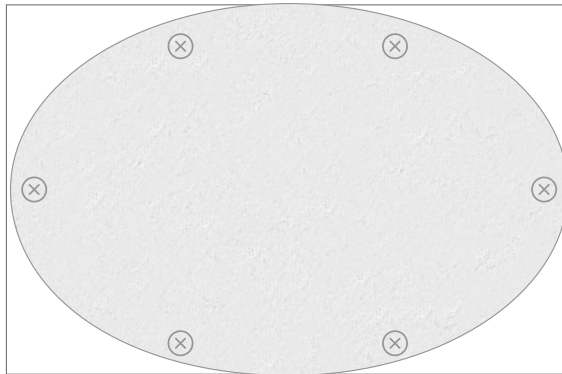
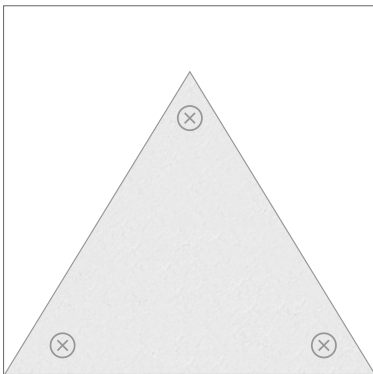

Connecting Rockfon System Eclipse Island to the structure

Please ensure that the supporting structure is solid and that it has a load bearing capacity of at least 25 kg. Attach the wire to the soffit fixing points. Slide the wire into the hook. The system locks automatically providing maximum safety. Attach the hooks to all of the spiral anchors. Ensure that all hooks are correctly attached before

raising the island to the required height. Use two people in order to prevent that the island is only attached by one or two hooks.

The maximum load per wire is 5 kg, and the minimum installation depth should be 150 mm.

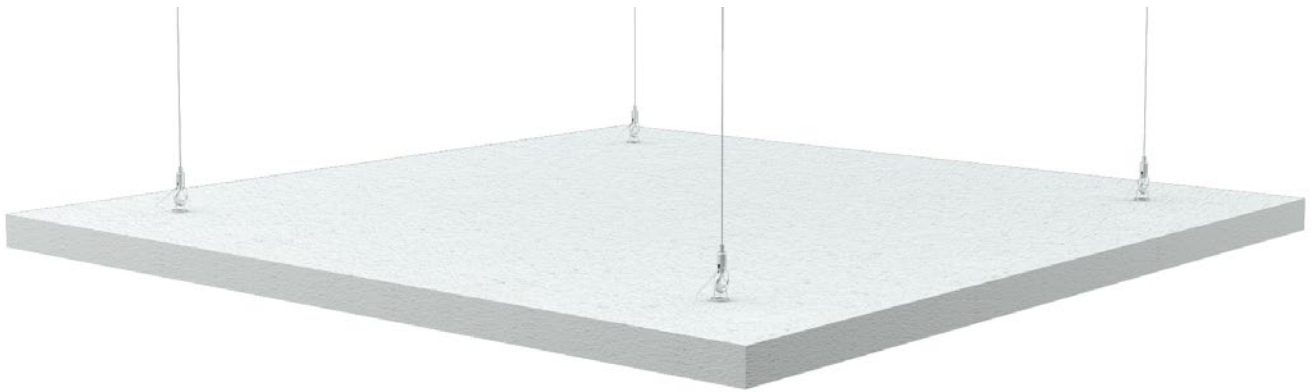

Levelling

Adjust the level by using a spirit level. Always make sure that the island is attached at all points so that the weight of the island is evenly distributed. Rockfon Eclipse can also be installed at a maximum angle of 45°.

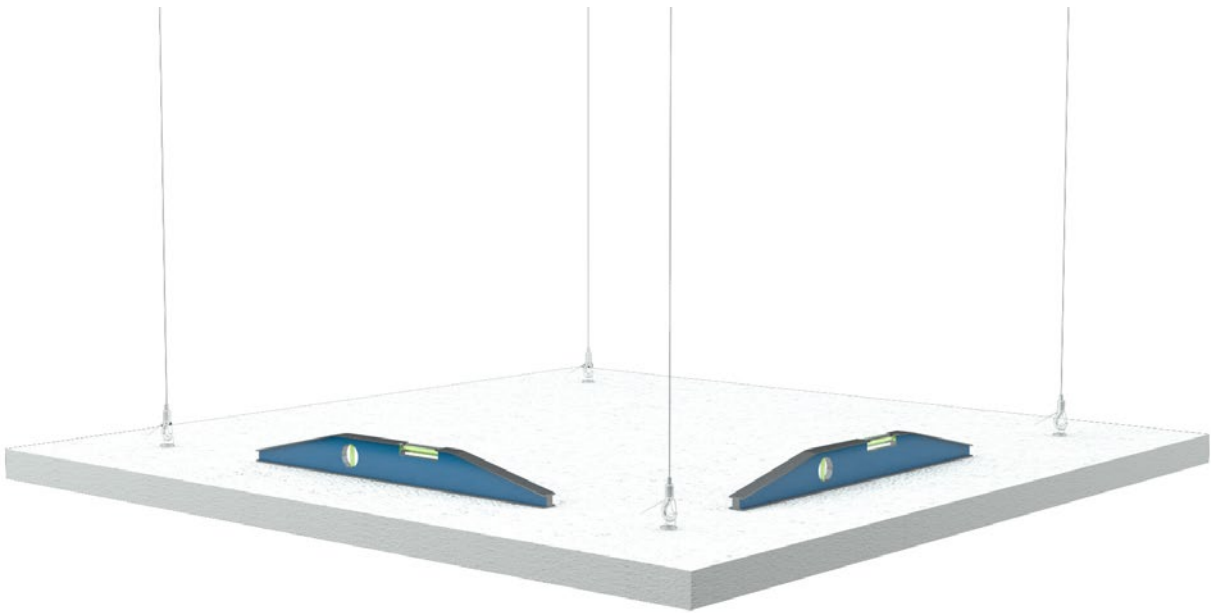

Installing Rockfon System Eclipse Island below an existing suspended ceiling

It is possible to suspend Rockfon Eclipse islands from an existing ceiling grid. Check to ensure that the grid can support the load of the islands. Various connection accessories are available and it should be confirmed that the accessory is compatible, can support a weight of 5kg, and can support the load of the island. Refer to illustrations 1 and 2.

It is also possible to install the Rockfon System Eclipse Island below a suspended ceiling by having the wires pass through the ceiling tiles and fixing the suspension kit to the structure (eg. concrete soffit) as in illustration N°3.

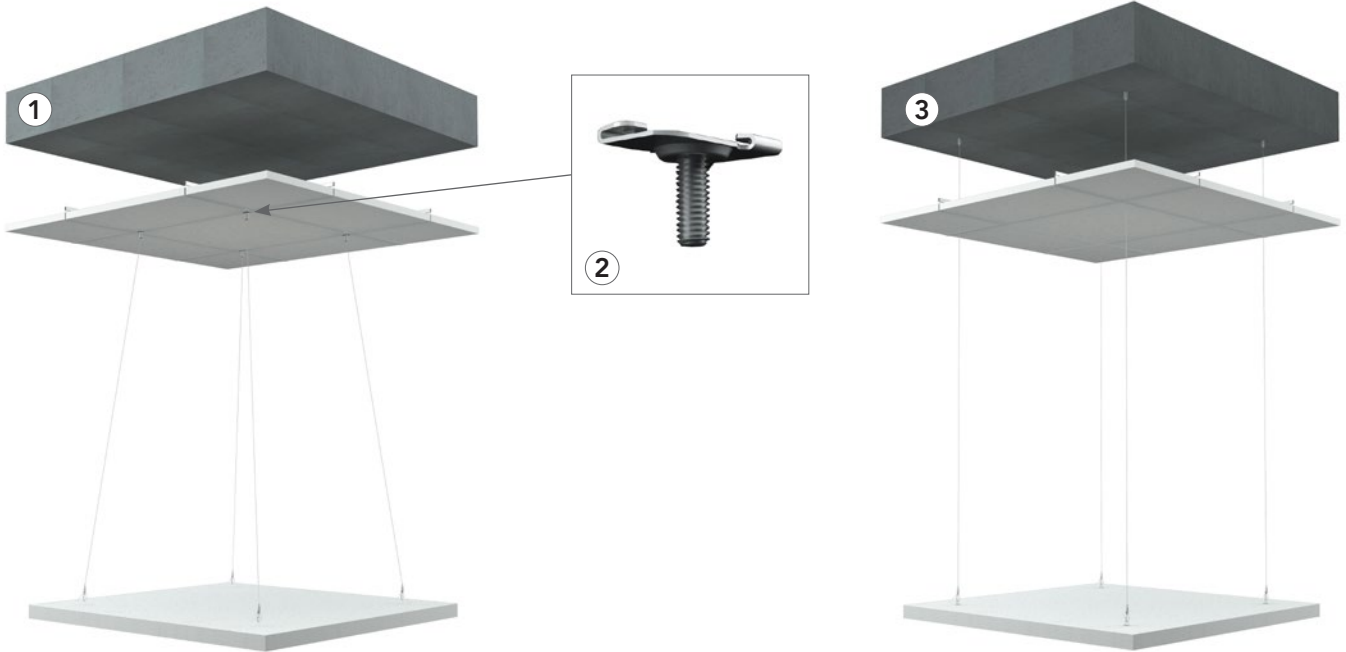

Installing Rockfon System Eclipse Island below an existing gypsum ceiling

Using a plate: Check with the plate supplier to ensure it can support a load of 5 kg per suspension point.

Drill a hole into the gypsum board. Slide the cable stopper plate through the hole and let it rest flat above the gypsum board.



Using a gypsum plug

Check with the gypsum plug supplier to ensure it can support a load of 5 kg. Screw the gypsum plug with an M6 fixing into the gypsum board.

Fix the Rockfon Eclipse Design suspension kit to the M6 fixing.

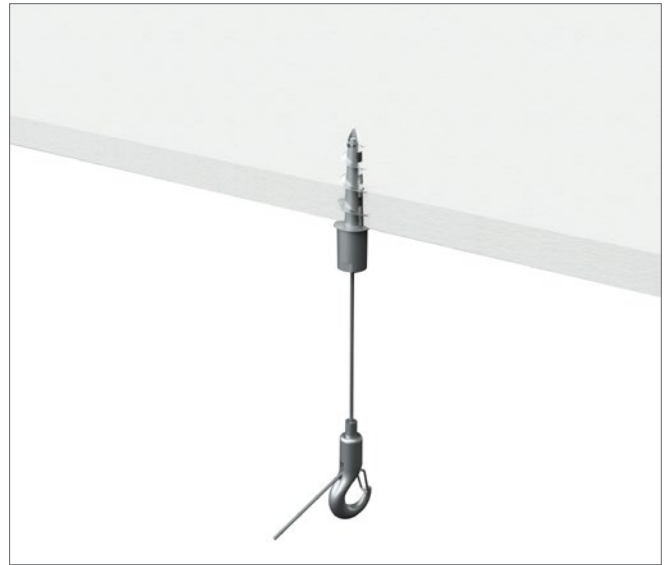
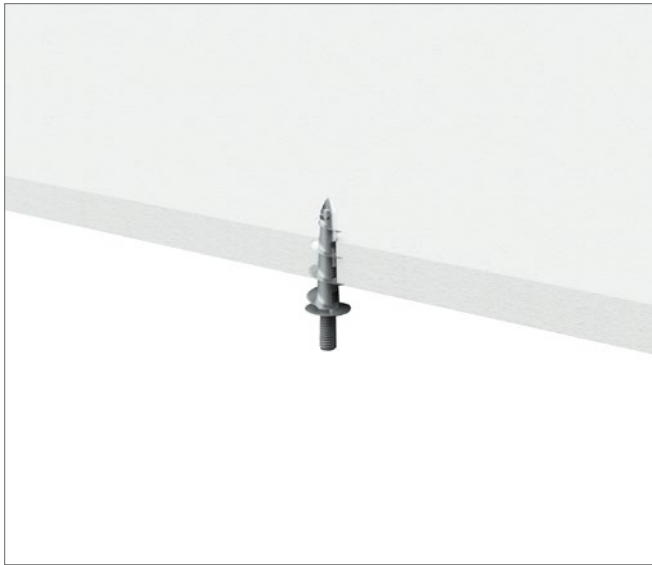

Using a spring toggle

- 1) Check with the spring toggle supplier to ensure it can support a load of 5 kg. Drill into the gypsum board. Screw the M6 threaded rod into the spring toggle. Insert it into the gypsum board.
- 2) Once the spring toggle passes through the other side of the gypsum board, it opens out and holds the threaded rod in place.
- 3) Screw the Rockfon Eclipse Design suspension kits into the M6 threaded rod.



Installing Rockfon System Eclipse Island direct on to the concrete soffit

Direct installation of Rockfon Eclipse to the concrete soffit is possible with the "shallow" direct fix bracket and the dedicated direct fix spiral anchor.

The space between the island and the concrete soffit will be approximately 15 mm.

Direct installation is not recommended for islands larger than 1200 x 1200 mm.

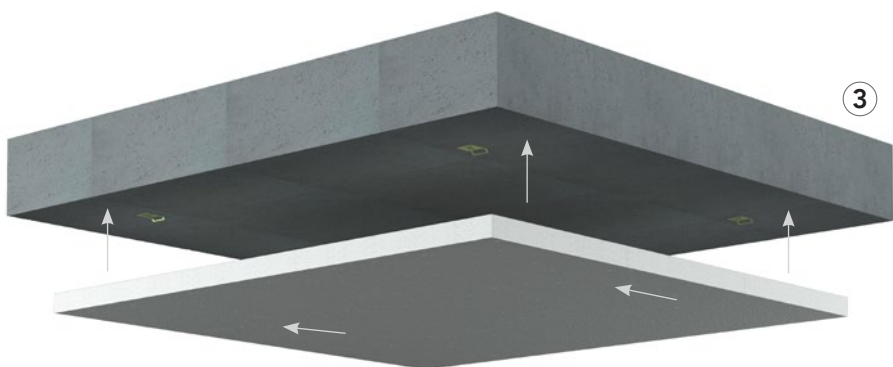
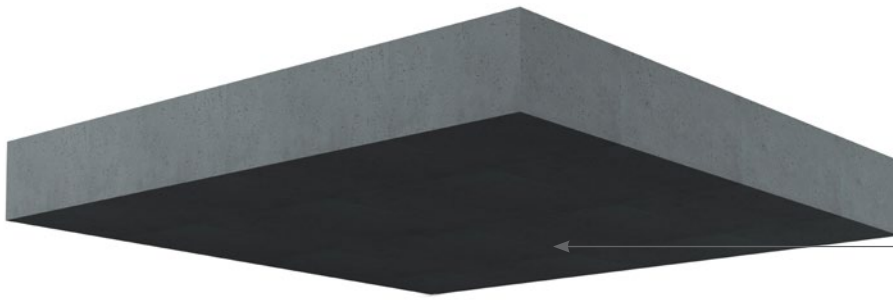

Lift island to the concrete soffit, then slide into the brackets.

Service integration

Rockfon Eclipse is easy to cut, making integration of service installations very easy. The cutouts can be made with a simple utility knife.

Light installation:

Adding lighting fixtures must be done independently. Rockfon System Eclipse Island should not support any additional material or fittings.

There is one exception though. A light fixture or beam light can be installed (max. 5 kg) in a Rockfon Eclipse Rectangle 2360 x 1160 mm, as long as all six suspension points are used.



Rockfon Eclipse Rectangle 2360 x 1160 mm

When a light fixture or beam light is installed (max. 5kg), all six suspension points should be used (see page 6).

A: Downlight (or similar service) integrated with yoke

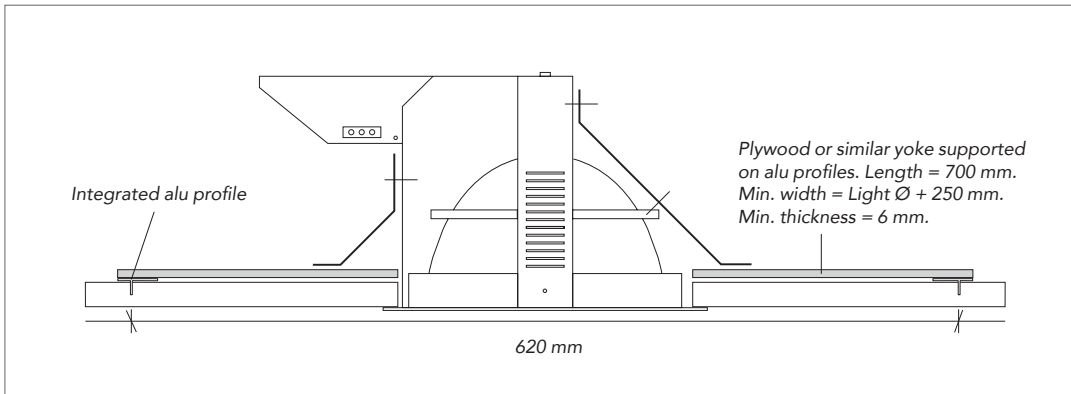

This solution is applicable for lights (or other services) and yokes weighing 5 kg. Cut a hole in the island and centre the yoke to match the size and shape of the light. If using "out of balance" light (as shown), ensure overhang is in line with the length of the yoke. Fit light into the island and yoke.

B: Downlight (or similar service) integrated with support arms

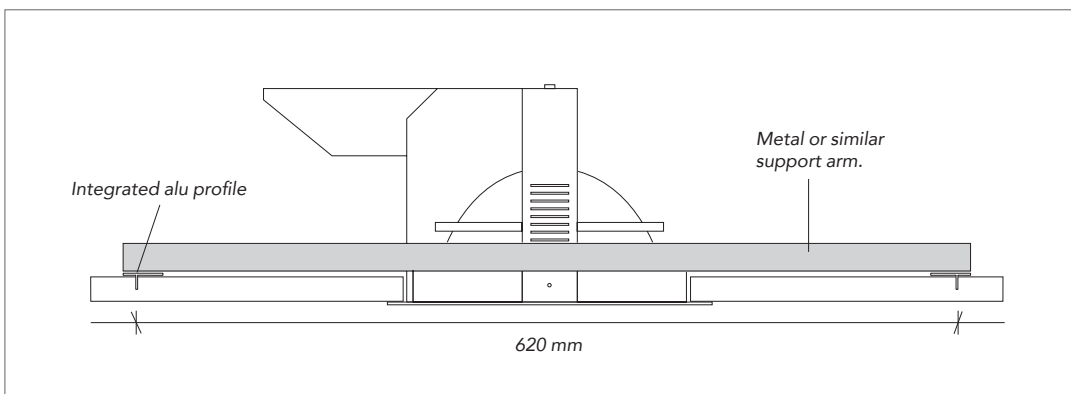

This solution is applicable for lights (or other services) weighing 5 kg. Support the light fixture using two support arms, that are resting on the integrated alu profiles. Cut a hole in the island to match the size and shape of the light fixture. If using "out of balance" light (as shown), ensure overhang is in line with the support arms.

Cutouts Rockfon Eclipse Square 1160 x 1160 mm / Rectangle 1760 x 1160 mm

- Distance from the long side: min. 0.2 x Length
- Distance from the short side: min. 0.25 x Width
- Max. cutout: 0.6 x Length x 0.5 x Width
- Min. distance between spiral anchor and cutout: 100 mm

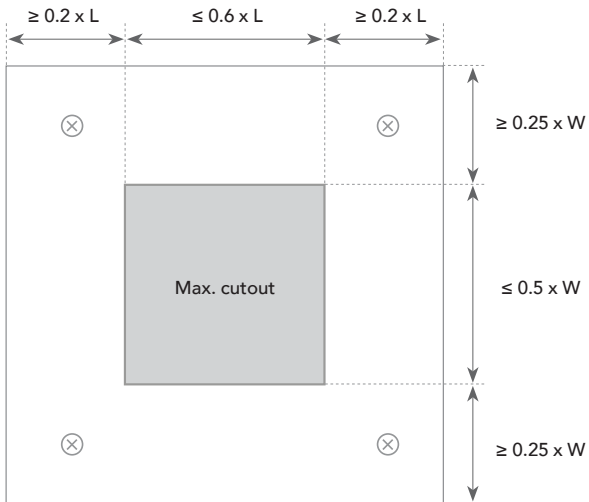

Example of Rockfon Eclipse Rectangle 1760 x 1160 mm

- Distance from the long side: min. 352 mm
- Distance from the short side: min. 290 mm
- Max. cutout: 1056 x 580 mm

Adding lighting fixtures must be done independently. Rockfon Eclipse should not support any additional material or fittings.

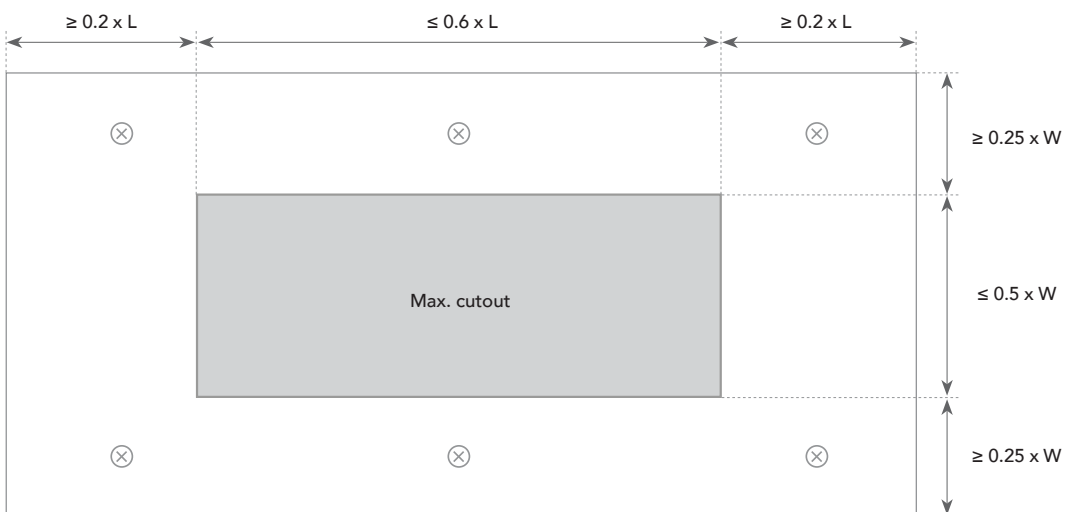

Cutouts Rockfon Eclipse Circle 800 / 1160

- Distance from the edge: min. 200 mm
- Min. distance between spiral anchor and cutout: 100 mm

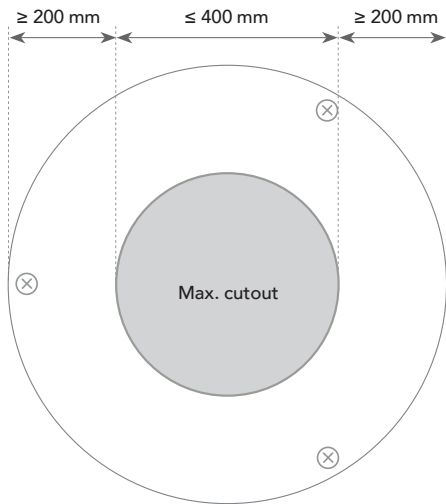

Example of Rockfon Eclipse Circle 1160

- Distance from the edge: min. 200 mm
- Max. cutout: \varnothing 760 mm

Adding lighting fixtures must be done independently. Rockfon Eclipse should not support any additional material or fittings.

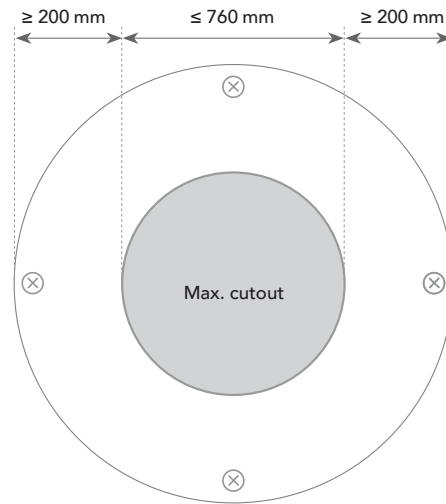

Cutouts Rockfon Eclipse Hexagon 1160

- Distance from the edge: min. 200 mm
- Min. distance between the spiral anchor and cutout: 100 mm

Example of Rockfon Eclipse Hexagon 1160

- Distance from the edge: min. 200 mm
- Max. cutout: length of one side 350 mm

Adding lighting fixtures must be done independently. Rockfon Eclipse should not support any additional material or fittings.

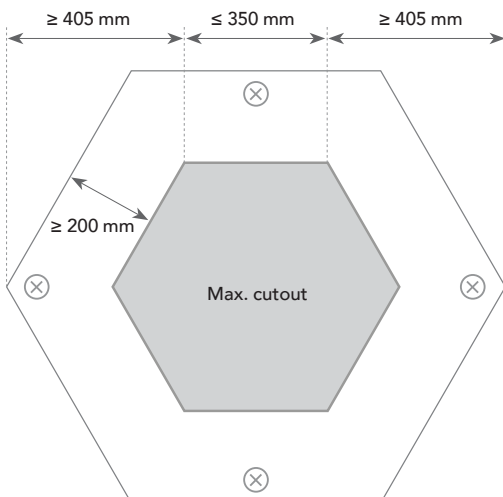

Cutouts Rockfon Eclipse Triangle 1160

- Distance from the edge: min. 200 mm
- Min. distance between the spiral anchor and cutout: 100 mm

Example of Rockfon Eclipse Triangle 1160

- Distance from the edge: min. 200 mm
- Max. cutout: Δ length of one side 468 mm

Adding lighting fixtures must be done independently. Rockfon Eclipse should not support any additional material or fittings.

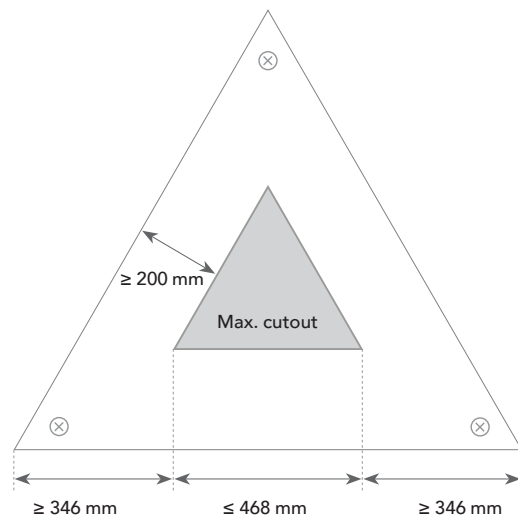

Cutouts Rockfon Eclipse Oval 1760

- Distance from the edge: min. 200 mm
- Min. distance between spiral anchor and cutout: 100 mm

Example of Rockfon Eclipse Oval 1760

- Distance from the edge: min. 300 mm
- Max. cutout: 560 x 1160 mm (in oval shape)

Adding lighting fixtures must be done independently. Rockfon Eclipse should not support any additional material or fittings.

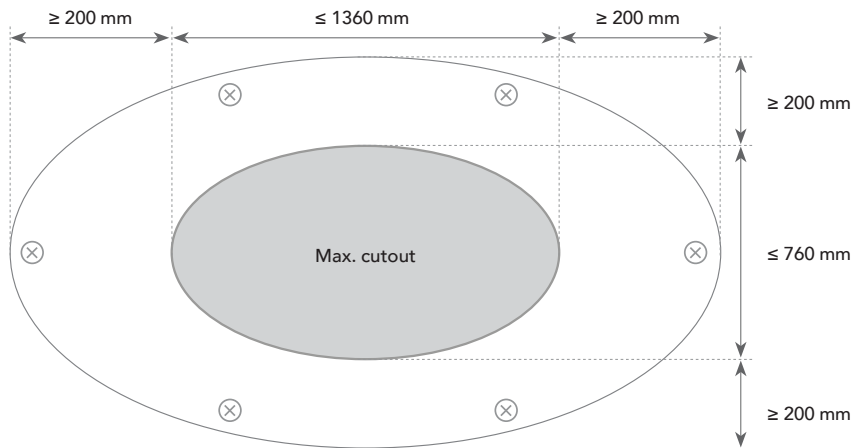

Cutouts Rockfon Eclipse Rectangle 2360

- Distance from the long side: min. $0.2 \times \text{Length}$
- Distance from the short side: min. $0.3 \times \text{Width}$
- Max. cutout: $0.6 \times \text{Length} \times 0.4 \times \text{Width}$

Example of Rockfon Eclipse Rectangle 2360 x 1160 mm

- Distance from the long side: min. 472 mm
- Distance from the short side: min. 348 mm
- Max. cutout: 1416 x 464 mm

A light fixture or beam light can be installed (max. 5kg) in Rockfon Eclipse Rectangle 2360 as long as the weight is being transferred to the integrated profiles and all six suspension points are used.

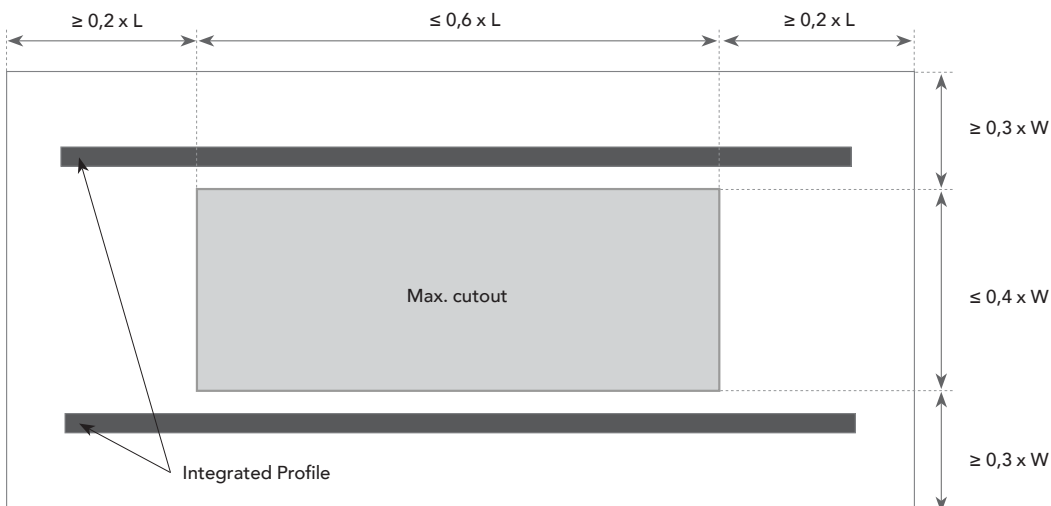

Common information on cutouts

- The dimensions in the drawings are maximum allowable cutouts.
- We advise to install lights or similar services symmetrically in the islands. Installation of lighting fixtures or other services should be completed according to the advice given above by Rockfon.
- We advise to use either a knife or a jigsaw to create the cutouts. However, the islands needs to be protected against scratches and dust. This can be done by putting a cardboard or paper between the jigsaw and the panel as protection.
- Other cutout forms are possible, as long as they don't exceed the max. cutout area.
- Instead of one large cutout it is also permitted to have several smaller cutouts, so long as they don't exceed the max. cutout area.
- For an optimum working environment, we recommend that installers always observe common workplace practices and follow the installation advice as shown on our packaging.

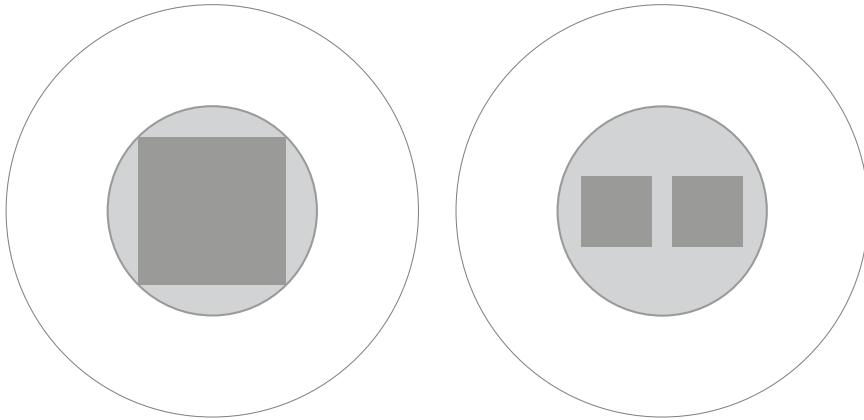

Rockfon Eclipse® and Rockfon Contour® edge repair filler

Edge repair filler for making good accidental edge damage caused during on-site handling or installation.

This filler was developed to repair dents or small holes, up to 15mm diameter, or scratches that may be caused during product mishandling.

The structure and colour of the filler is identical to factory applied Rockfon Eclipse and Rockfon Contour edge paint, making site repairs virtually undetectable.

It is easy to apply and quick drying.



Tools

We have developed specific tools that are available on www.rockfon.co.uk.

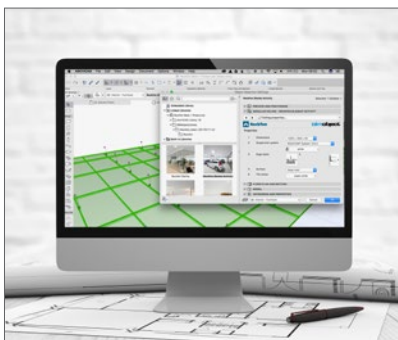

Visit our online CAD Library or BIM portal to assist you in your project design.

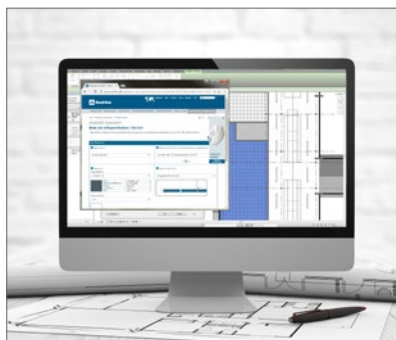

Generate specification texts for our products.

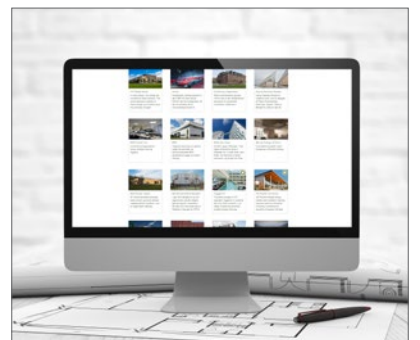

Explore our vast library of reference projects.

Rockfon® is a registered trademark
of the ROCKWOOL Group.

 twitter.com/RockfonUK

 linkedin.com/company/Rockfon-uk/

 instagram.com/Rockfon_official/

 youtube.com/RockfonUK

06:2019 | 06:2019 | | All colour codes mentioned are based on the NCS - Natural Colour System® property of and used on license from NCS Colour AB, Stockholm 2012 or the RAL colour standard. Subject to alterations in range and product technology without prior notice. Rockfon accepts no responsibility for printing errors.



Rockfon

ROCKWOOL Limited T/A Rockfon
14th Floor, Chiswick Tower, 389 Chiswick High Road,
London W4 4AL
Tel: +44 (0) 208 222 7457
Fax: +44 (0)20 8222 7458
www.rockfon.co.uk