

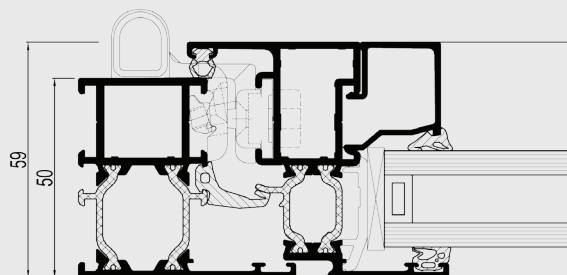

ES 50

Simply smart

R
REYNAERS
aluminium

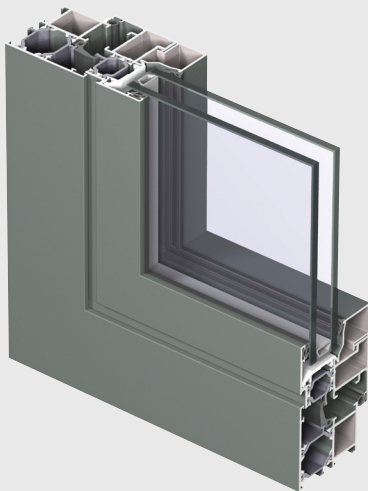

Eco System® 50 is a well-insulated system for windows and doors, that combines aesthetic design and energy efficiency with a moderate price. The system's HI+ variant achieves U_f values down to $1.6 \text{ W/m}^2\text{K}$. The U_f of a frame/vent section with 86 mm visible width is $2.3 \text{ W/m}^2\text{K}$.

The system's limited built-in depth allows its application in many constructions, even with reduced wall thicknesses. Design wise, ES 50 offers, next to the functional design frames, special block profiles resembling wooden frames. The use of invisible fittings results in an even more elegant look, since hinges are no longer in sight.

In addition, ES 50 can comply with burglar resistance class 2, offering a safe and secure solution both for residential constructions and utility buildings.



ES 50

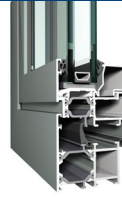

TECHNICAL CHARACTERISTICS

Min. visible width inward opening window	Frame	48 mm
	Vent	30 mm
Min. visible width outward opening window	Frame	21 mm
	Vent	87 mm
Min. visible width inward opening flush door	Frame	67 mm
	Vent	74 mm
Min. visible width outward opening flush door	Frame	42 mm
	Vent	99 mm
Min. visible width T-profile		70 mm
Overall system depth window	Frame	50 mm
	Vent	59 mm
Overall system depth flush door	Frame	50 mm
	Vent	50 mm
Rebate height		22 mm
Glass thickness		up to 32 mm
Glazing method		dry glazing with EPDM or neutral silicones
Thermal insulation		omega-shaped fibreglass reinforced polyamide strips (frame 26.3 mm - vent 22 mm)
High Insulation Plus variant (HI+)		Available

PERFORMANCES

ENERGY												
	Thermal Insulation ⁽¹⁾ EN 10077-2	Uf-value down to 1.6 W/m ² K depending on the frame/vent combination and the glass thickness										
COMFORT												
	Acoustic performance ⁽²⁾ EN ISO 140-3; EN ISO 717-1	Rw (C; Ctr) = 35 (-1; -4) dB / 39 (-1; -3) dB, depending on glazing type										
	Air tightness, max. test pressure ⁽³⁾ EN 1026; EN 12207	1 (150 Pa)		2 (300 Pa)		3 (600 Pa)		4 (600 Pa)				
	Water tightness ⁽⁴⁾ EN 1027; EN 12208	1A (0 Pa)	2A (50 Pa)	3A (100 Pa)	4A (150 Pa)	5A (200 Pa)	6A (250 Pa)	7A (300 Pa)	8A (450 Pa)	9A (600 Pa)	E (750 Pa)	
	Wind load resistance, max. test pressure ⁽⁵⁾ EN 12211; EN 12210	1 (400 Pa)		2 (800 Pa)		3 (1200 Pa)		4 (1600 Pa)		5 (2000 Pa)		Exxx (>2000 Pa)
	Wind load resistance to frame deflection ⁽⁵⁾ EN 12211; EN 12210	A (≤1/150)			B (≤1/200)			C (≤1/300)				
SAFETY												
	Burglar resistance ⁽⁶⁾ ENV 1627 - ENV 1630	WK 1			WK 2 (windows & doors)			WK 3				

This table shows possible classes and values of performances. The values indicated in red are the ones relevant to this system.

- (1) The Uf-value measures the heat flow. The lower the Uf-value, the better the thermal insulation of the frame.
- (2) The sound reduction index (Rw) measures the capacity of the sound reduction performance of the frame.
- (3) The air tightness test measures the volume of air that would pass through a closed window at a certain air pressure.
- (4) The water tightness testing involves applying a uniform water spray at increasing air pressure until water penetrates the window.
- (5) The wind load resistance is a measure of the profile's structural strength and is tested by applying increasing levels of air pressure to simulate the wind force. There are up to five levels of wind resistance (1 to 5) and three deflection classes (A,B,C). The higher the number, the better the performance.
- (6) The burglar resistance is tested by static and dynamic loads, as well as by simulated attempts to break in using specified tools.

