

# dowel systems

Specification Sheet  
Issue 2.1  
11/10/2013

dowel systems

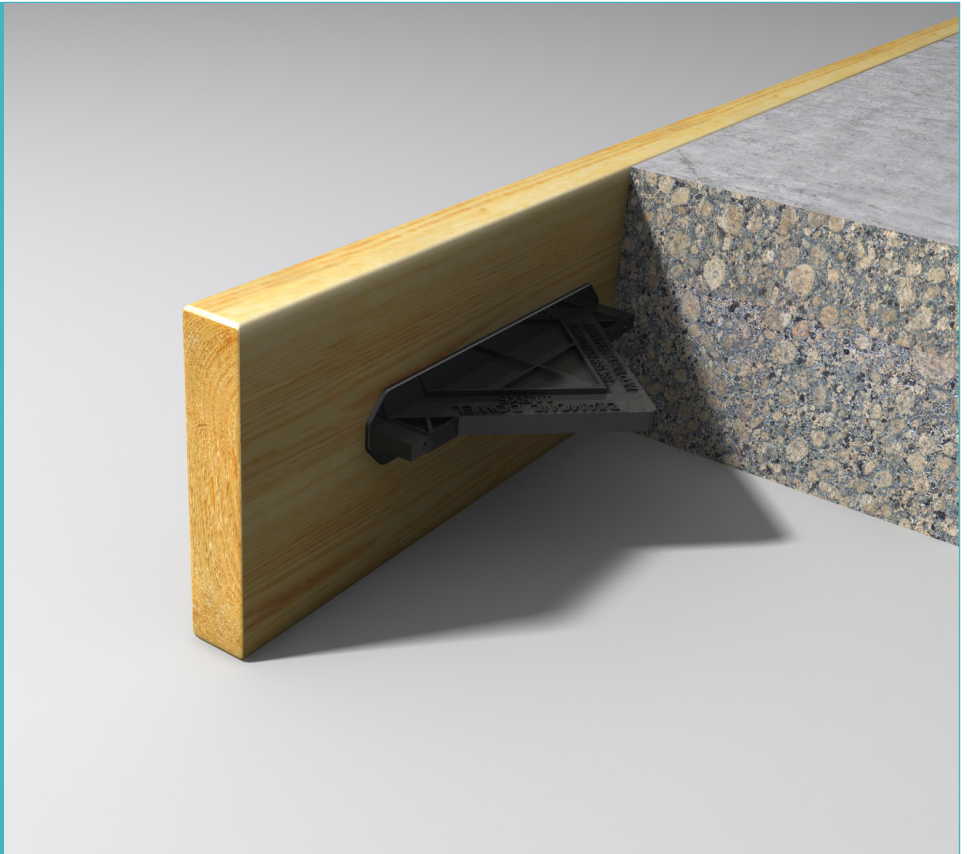

dowel systems

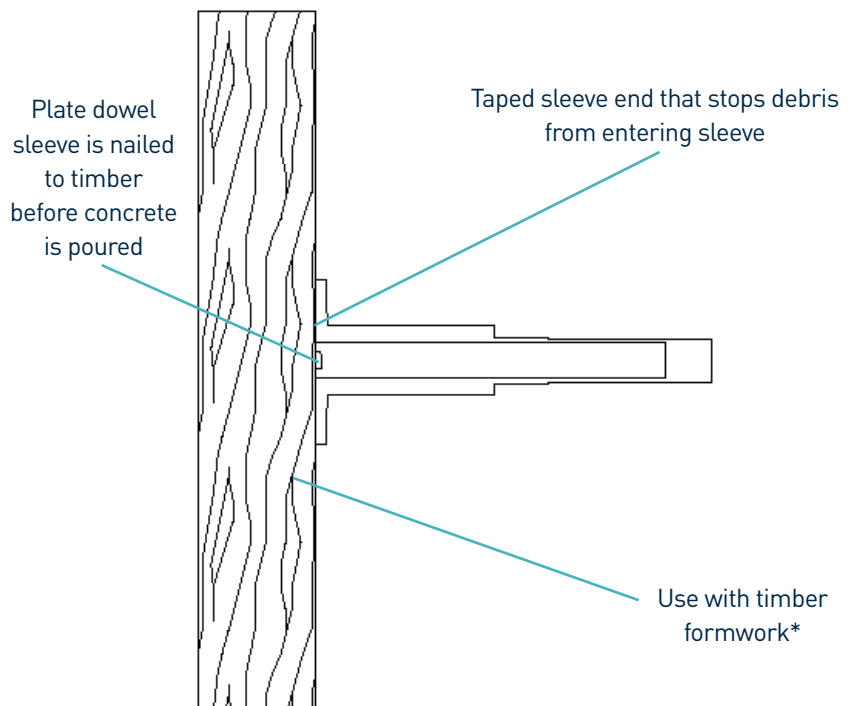

Plate dowel system shown. \*Not supplied

# dowel systems

Specification Sheet Issue 2.1

11/10/2013

## manufacturing tolerances

**Length** ±2.0mm

**Thickness** ±0.4mm

## dimensions of dowel systems

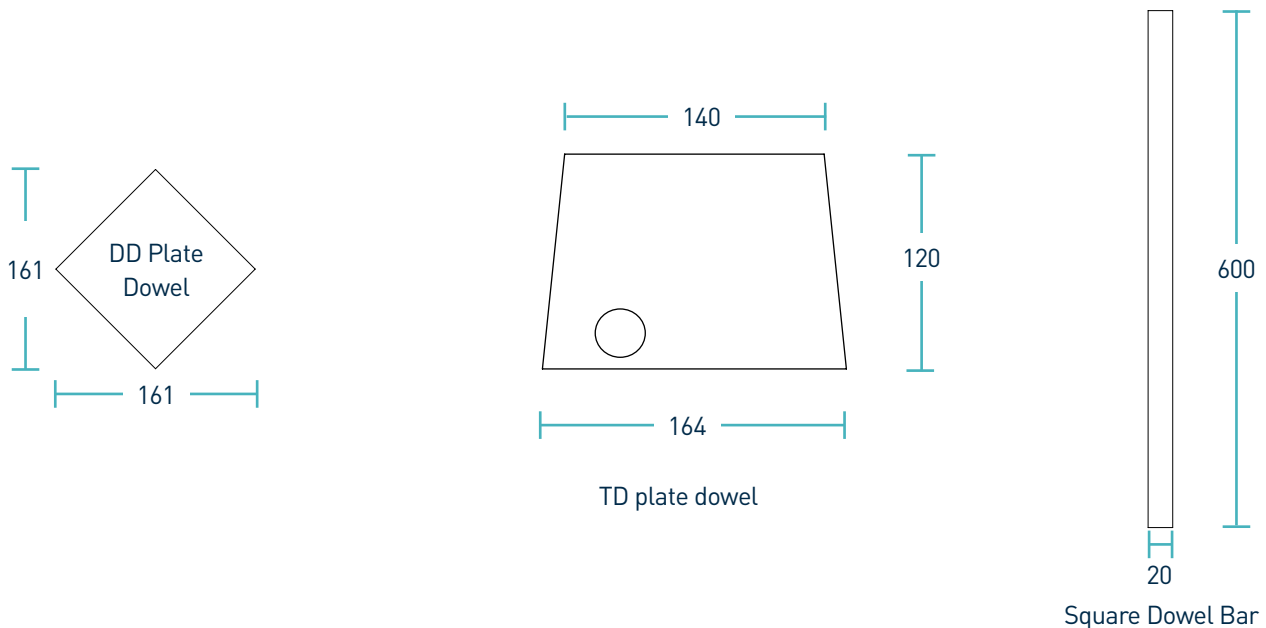

## weight of packaging information

Dowel Type	Single Dowel Weight (kg)	Single Sleeve Weight (kg)
DD6 Plate Dowel	0.6	0.1
DD10 Plate Dowel	1.0	0.2
TD10 Plate Dowel	1.0	0.2
Square Dowel Bar	1.9	0.2

Weight values shown are approximate.

## materials

Component	Material
Plate dowel	BS EN 10025-2:2004 S275JRG2 min 410 N/mm <sup>2</sup>
Plate dowel sleeve	ABS
Square dowel bar	BS EN 10025-2:2004 S275JR
Square dowel bar sleeve	PP

# dowel systems

Specification Sheet Issue 2.1

11/10/2013

## theoretical calculated ultimate loads at failure of dowel or concrete

(For ground supported slabs,  
40N/mm<sup>2</sup> concrete and 20mm  
joint opening)

Slab Depth (mm)	Dowel Type	Unreinforced Slab			Steel Fibre Reinforced Slab (Re3 = 0.8)		
		Bursting (kN/m)	Bending (kN/m)	Combined Bending and Shear (kN/m)	Bursting (kN/m)	Bending (kN/m)	Combined Bending and Shear (kN/m)
150	DD6	60.17	58.65	64.22	103.84	58.65	64.22
	DD10	45.13	122.19	116.93	77.88	122.19	116.93
	TD10	50.50	224.34	214.67	87.17	224.34	214.67
	Square Bar	42.00	145.00	105.30	72.50	145.00	105.30
200	DD6	69.30	58.65	64.22	118.60	58.65	64.22
	DD10	74.83	122.19	116.93	129.14	122.19	116.93
	TD10	82.00	224.34	214.67	141.67	224.34	214.67
	Square Bar	56.00	145.00	105.30	96.60	145.00	105.30
250	DD6	82.63	58.65	64.22	138.89	58.65	64.22
	DD10	94.24	122.19	116.93	159.04	122.19	116.93
	TD10	81.00	224.34	214.67	136.50	224.34	214.67
	Square Bar	70.00	145.00	105.30	118.00	145.00	105.30
300	DD6	90.72	58.65	64.22	153.19	58.65	64.22
	DD10	97.24	122.19	116.93	164.19	122.19	116.93
	TD10	87.33	224.34	214.67	147.50	224.34	214.67
	Square Bar	80.40	145.00	105.30	135.70	145.00	105.30
350	DD6	95.95	58.65	64.22	163.41	58.65	64.22
	DD10	103.36	122.19	116.93	176.04	122.19	116.93
	TD10	94.00	224.34	214.67	160.00	224.34	214.67
	Square Bar	88.80	145.00	105.30	151.33	145.00	105.30

This table shows the load at failure of our dowel systems at a joint opening of 20mm - larger joint openings can be accommodated. The ultimate load has been calculated in accordance with TR34 3rd Edition and assumes dowel spacings of: **DD6 = 450mm, DD10 = 600mm, TD10 = 600mm, Square Bar = 300mm**. For more detailed analysis please contact Permaban.

