

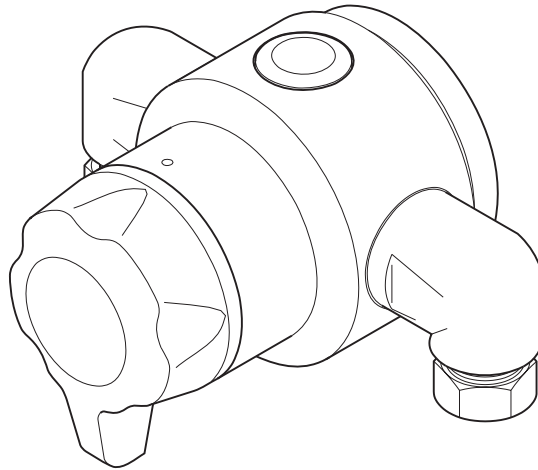

Meynell

V8/3

THERMOSTATIC MIXING VALVE



PRODUCT MANUAL

IMPORTANT

Installer: This Manual is the property of the customer and must be retained with the product for maintenance and operational purposes.

CONTENTS

Safety : Warnings	3
Advice.....	3
Description.....	4
Pack Contents	5
Dimensions	7
Specifications	8
Installation Requirements	10
Installation	12
General.....	12
Reverse Outlet Connector	13
1. Exposed Models	14
2. Built-in Models.....	15
Commissioning	17
Exercising the Thermostat.....	17
Commissioning Checks.....	17
Maximum Temperature.....	18
Maximum Temperature Setting	18
Operation	19
Fault Diagnosis.....	20
Maintenance.....	21
General.....	21
Planned Maintenance.....	22
Healthcare.....	22
Frequency of In-service Tests	22
Checkvalves and Filters	23
Type 2 and Type 3 Valves.....	25
Application.....	25
Installation Conditions	26
Commissioning.....	26
Maintenance.....	27
Spare Parts	28
Notes	30
Customer Care.....	Back Page

SAFETY : WARNINGS

The function of a thermostatic mixing valve is to deliver water consistently at a safe temperature. This requires that:

1. It is installed, commissioned, operated and maintained in accordance with the recommendations given in this manual.
2. Type 2 and 3 valves are only used for applications covered by their approved designations.
3. Periodic attention is given, as necessary, to maintain the product in good functional order. Recommended guidelines are given in section: **'Maintenance'**.
4. Continued use of this product in conditions outside the specification limits given in this Manual can present potential risk to users.

ADVICE

The use of the word 'failsafe' to describe the function of a thermostatic mixing valve is both incorrect and misleading. In keeping with every other mechanism it cannot be considered as being functionally infallible.

Provided that the thermostatic mixing valve is installed, commissioned, operated within the specification limits and maintained according to this Manual, the risk of malfunction, if not eliminated, is considerably reduced.

Malfunction of thermostatic mixing valves is almost always progressive in nature and will be detected by the use of proper temperature checking and maintenance routines.

Certain types of system can result in the thermostatic mixing valve having excessive 'dead-legs' of pipework. Others allow an auxiliary cold water supply to be added to the mixed water from the mixing valve. Such systems can disguise the onset of thermostatic mixing valve malfunction.

Ultimately, the user or attendant must exercise due diligence to ensure that the delivery of warm water is at a stable, safe temperature. This is particularly important in such healthcare procedures as supervised bathing of patients unable to respond immediately to unsafe temperatures.

If you experience any difficulty with the installation or operation of your new Mixing Valve, then please refer to "**Fault Diagnosis**", before contacting Kohler Mira Ltd. Our telephone and fax numbers can be found on the back cover of this guide.

INTRODUCTION

The Meynell V8/3 is a Thermostatic Mixing Valve specified to meet the highest standards of safety, and reliability as demanded by today's users. All Meynell products are designed, manufactured and supported in accordance with accredited BS EN ISO 9001: 2000 Quality Systems.

This Manual covers all Meynell V8/3 Thermostatic Mixing Valves manufactured from June 1997.

The suffix '3' indicates that this mixer has been certified for use in UK Healthcare premises as a Type 3 valve under the BUILDCERT TMV3 scheme. For Healthcare installation refer to section: '**Type 2 and Type 3 Valves**'. In this case this product has also been certified as a Type 2 valve under the BUILDCERT TMV2 scheme. This product also complies with the Water Supply (water fittings) Regulations 1999.

DESCRIPTION

A point of use Thermostatic Mixing Valve designed to supply temperature controlled hot water to both single and multi-point installations.

Meynell V8/3:

Exposed or built-in model with stub lever, all chrome finish, swivel elbows except rising, falling or rear entry supplies. 15 mm compression inlet, 1/2" BSP or 15 mm outlet connections.

Meynell V8/3 L:

Exposed or built-in model with long lever for disabled use, all chrome finish, 15 mm compression inlet, 1/2" BSP or 15 mm outlet connections.

Meynell V8/3 K:





Exposed model with locked (non-adjustable) control knob, all chrome finish, 15 mm compression inlet, 1/2" BSP or 15 mm compression outlet connections.

PACK CONTENTS

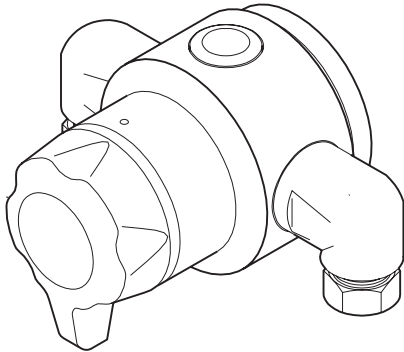

Tick the appropriate boxes to familiarize yourself with the part names and to confirm that the parts are included.

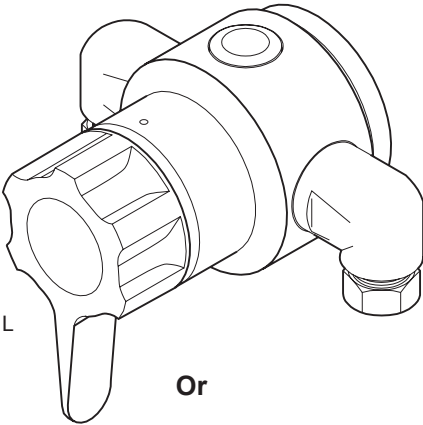
Exposed Models

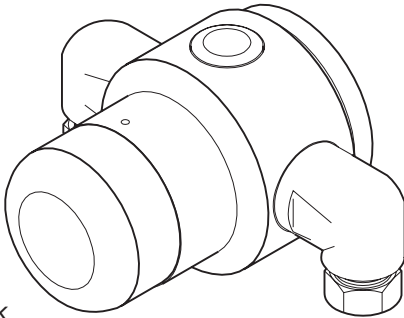
<input type="checkbox"/> 1 x V8/3		}		<input type="checkbox"/> 1 x Hexagonal Key
	<p style="text-align: center;">Or</p>			<input type="checkbox"/> 3 x Fixing Screws
<input type="checkbox"/> 1 x V8/3 L				<input type="checkbox"/> 1 x Olive
	<p style="text-align: center;">Or</p>		<input type="checkbox"/> 1 x Compression Nut	
<input type="checkbox"/> 1 x V8/3 K				

Documentation

1 x NHS Requirements Booklet

Built-in Models

1 x V8/3 B

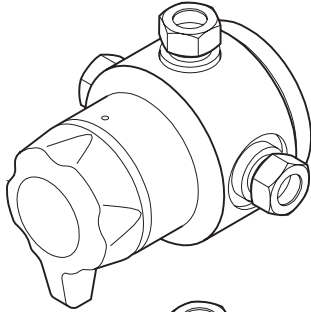

1 x V8/3 BL

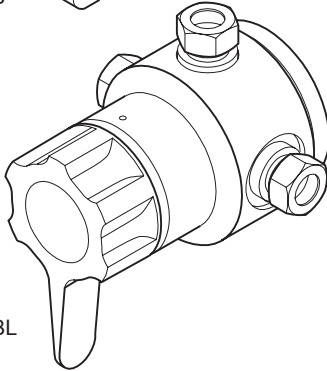

1 x Hexagonal Key



3 x Fixing Screws

1 x Foam Seal

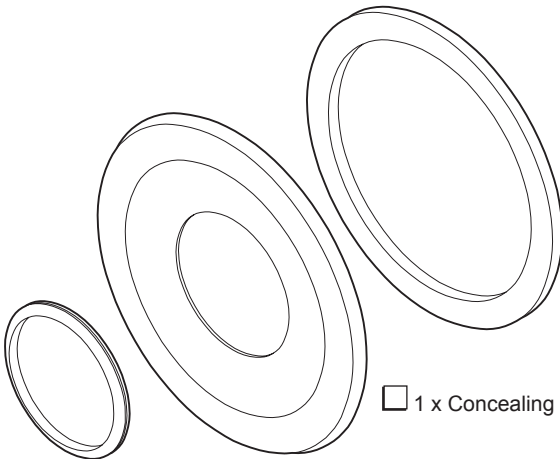

1 x Concealing Plate

1 x Rubber Grommet

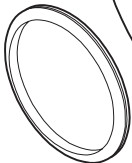

Documentation

1 x NHS Requirements Booklet

DIMENSIONS

Exposed Model

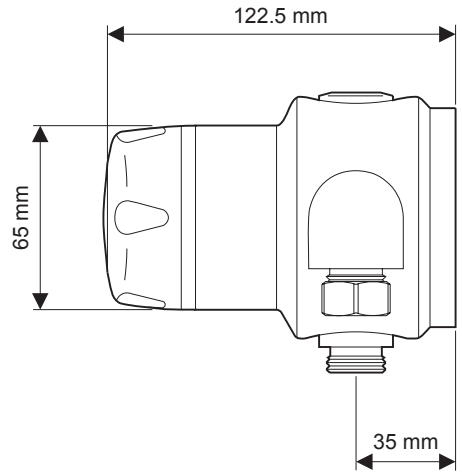
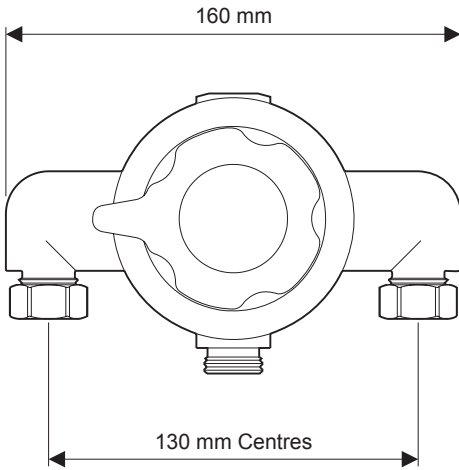

Built-in Model

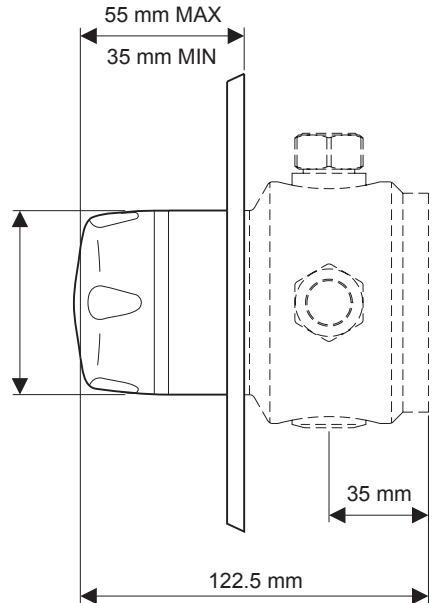
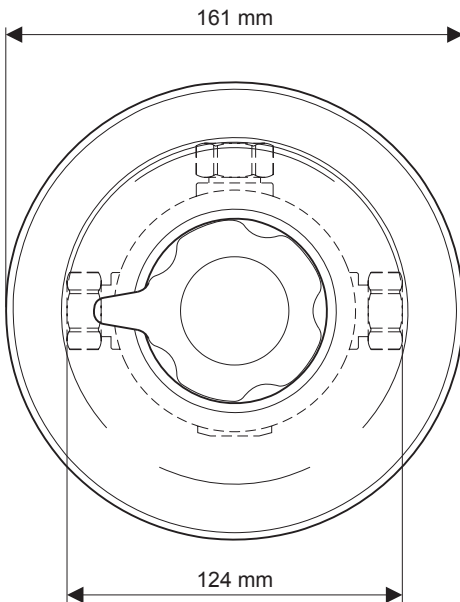

SPECIFICATIONS

Normal Operating Conditions are considered as:

- inlet maintained pressures are nominally balanced
- daily usage 1-6 hours
- installation and usage environment not subject to extremes of temperature, unauthorised tampering or wilful abuse.

Operating Parameters

For Type 2 and 3 valves the supply conditions specified in section: '**Type 2 and Type 3 Valves, Application**' take precedence over the operating parameters which follow.

Pressures And Flow Rates

For optimum performance, maintained supply pressures should be nominally equal.

Maximum Pressure Loss Ratio: **10:1**

Minimum Maintained Pressure: **0.1 bar** (= 1 metre head from underside of cold tank to outlet of shower fitting)

Maximum Static Pressure: **10 bar**

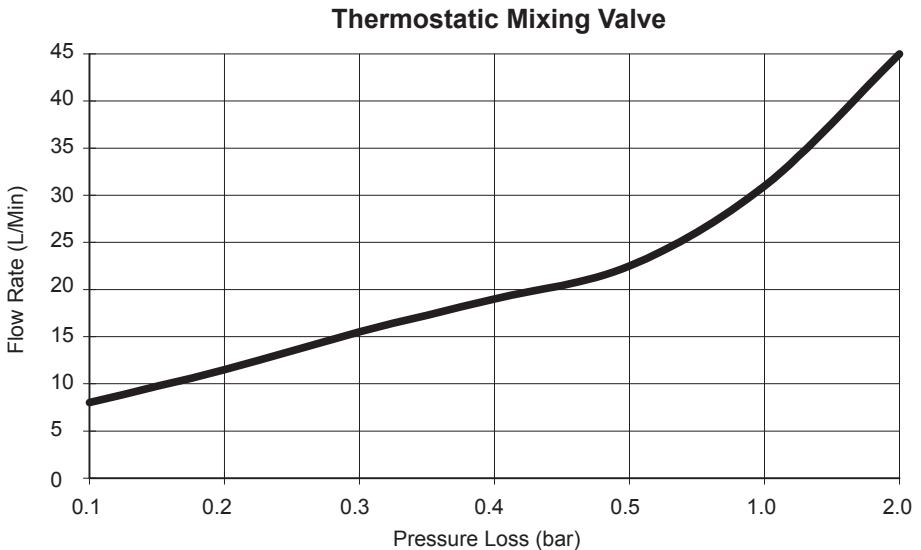

Temperature Control

Minimum temperature differential between hot and outlet temperature: **10°C**

Optimum temperature control range: **35 - 45°C**

Maximum hot water temperature: **85°C** (for safety, a recommended hot water storage temperature maintained below 85°C and for ablutionary installations at between **60 to 65°C**).

The performance specification outlined below is achieved with outlet blend temperature set between 35 - 45°C and supplies of 15°C cold and 65°C hot with nominally equal pressures.

- Outlet blend temperature is maintained within 2°C with a 10°C change in hot or cold supply.
- Thermostatic shut down to seepage within 2 seconds if cold supply fails. This is achieved only if the hot supply temperature is 10°C above the set outlet blend temperature.

Connections

Inlet connectors are 15 mm compression

Outlet connector is 1/2" BSP Male or 15 mm compression

Hot (H) and Cold (C) inlets are clearly marked and must be connected this way.

INSTALLATION REQUIREMENTS

Key to Symbols

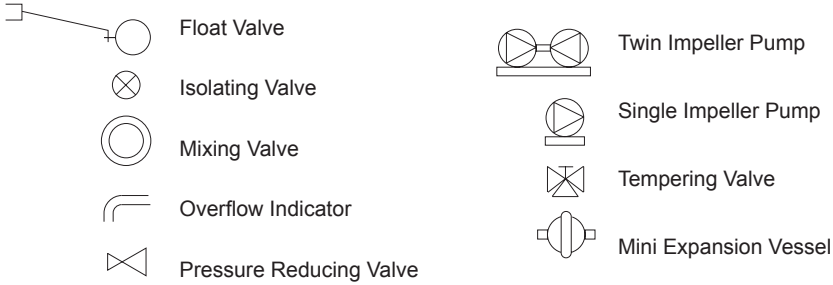

The Meynell V8/3 Thermostatic Mixing Valve is compatible with the following systems:

Gravity fed system

The Mixing Valve **MUST** be fed from a cold water cistern and hot water cylinder providing nominally equal pressure.

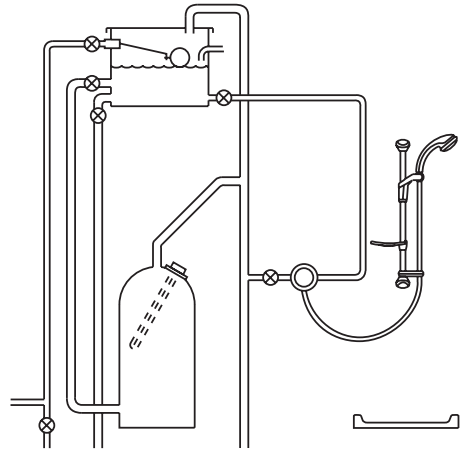

Gas heated system

The Mixing Valve **MUST** be installed with a gas water heater or combination boiler of a fully modulating design.

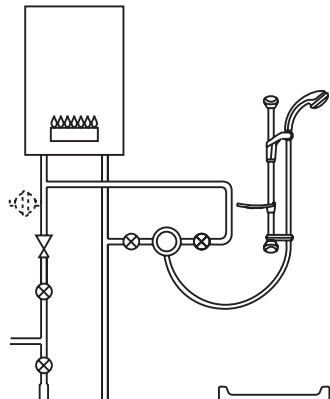

Unvented mains pressure system

The Mixing Valve can be installed with a unvented, stored hot water cylinder.

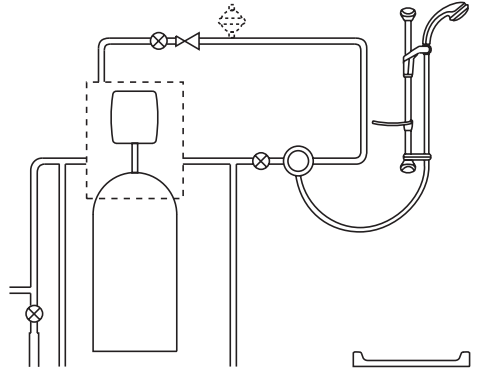

Mains pressurised instantaneous hot water system (thermal store)

The Mixing Valve can be installed with systems of this type with balanced pressures.

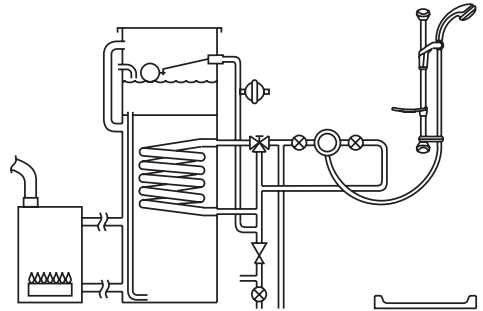

Pumped system

The Mixing Valve can be installed with an inlet pump (twin impeller). The pump must be installed on the floor next to the hot water cylinder.

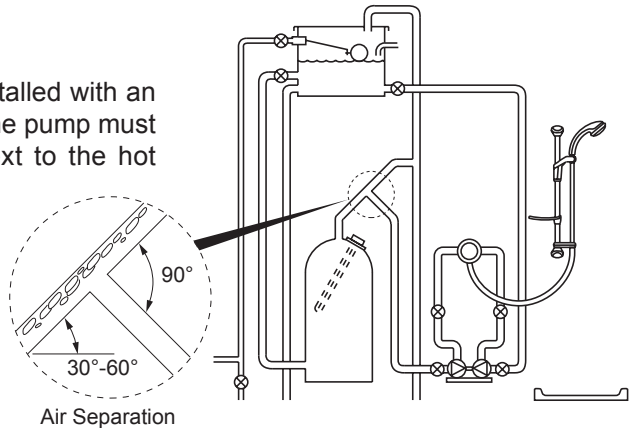

INSTALLATION

General

Installation must be carried out in accordance with these instructions, and must be conducted by designated, qualified and competent personnel.

1. Before commencing, make sure that the installation conditions comply with the information given in section: '**Specifications**'. For Type 2 and 3 valves see also Installation conditions in section: '**Type 2 and Type 3 Valves**'.
2. Care must be taken during installation to prevent any risk of injury or damage.
3. The mixing valve should be positioned for easy access during use and maintenance. All routine maintenance procedures can be conducted with the mixing valve body in place (except for strainer and checkvalve access). For all models, allow a minimum 80 mm clearance in front of the temperature control to enable removal of the serviceable parts during maintenance. Conveniently situated isolating valves must be provided for maintenance.
4. The use of supply-line or zone strainers will reduce the need to remove debris at each mixing valve point. The recommended maximum mesh aperture dimension for such strainers is 0.5 mm. Inlet pressure tapings which allow measurement of inlet pressure to the mixing valve under operating conditions are particularly recommended for healthcare with Type 2 and 3 valves.
5. Pipework must be rigidly supported.
6. Pipework dead-legs should be kept to a minimum. The mixed water outlet piping should not exceed 2 m and the overall length from the hot water circuit to the discharge point should not exceed 5 m.
7. Supply pipework layout should be arranged to minimise the effect of other outlet usage upon the dynamic pressures at the mixing valve inlets.
8. Inlet and outlet threaded joint connections should be made with PTFE tape or liquid sealant. Do not use oil-based, non-setting jointing compounds.
9. To eliminate pipe debris it is essential that supply pipes are thoroughly flushed through before connection to the mixing valve.

10. Decide on a suitable position for the Mixing Valve. The position of the Mixing Valve and the Shower Fittings must provide a minimum gap of 25 mm between the spill-over level of the shower tray/bath and the handset. This is to prevent back-siphonage. For further information on the installation of your shower fittings, refer to the Fittings Installation and User Guide.

Note! Only use shower fittings recommended by the manufacturer or supplier.

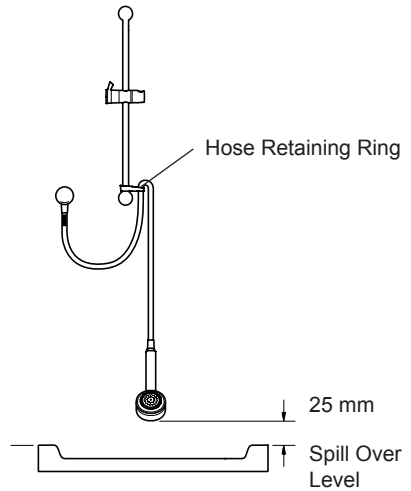

Reverse Outlet Connector

If the Shower Outlet needs to be reversed (e.g. bottom outlet to top outlet):

1. Remove the Blanking Cap (if fitted).
2. Using a 1/2" hexagonal key remove the Sealing Plug from the top and the Outlet Connector from the bottom of the Thermostatic Mixing Valve.
3. Swap around and refit, if changing from flat connector to compression make sure that the 'O' Seal is changed around.
4. Refit in reverse order.

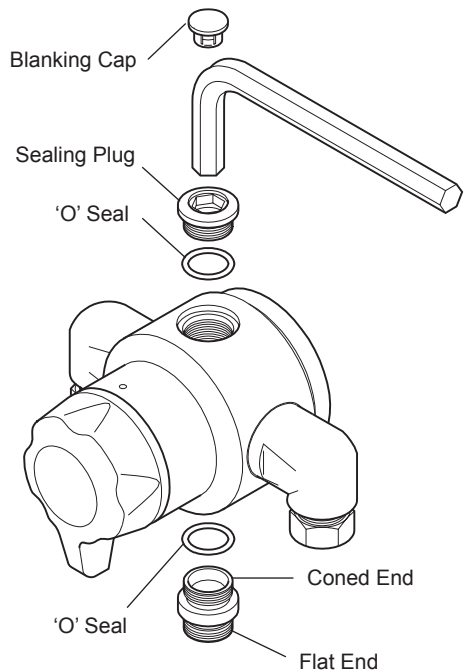
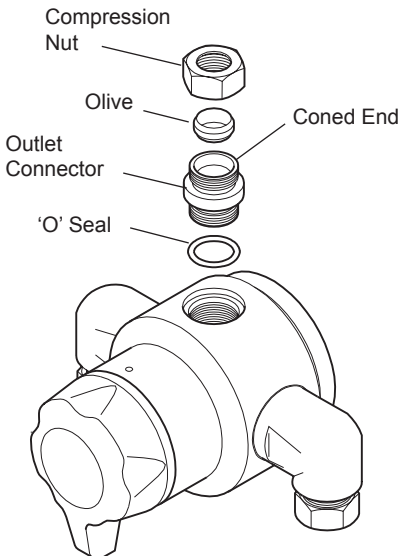

1. Exposed Models

- 1.1 Decide on a suitable position for the Thermostatic Mixing Valve where all users can operate it.
- 1.2 Remove the Wall Bracket from the rear of the Mixer Valve Body by loosening the Wall Bracket Grubscrew with a 2.5 mm hexagonal key (supplied).
- 1.3 Use the Wall Bracket to mark 3 hole positions. Drill wall and insert suitable Wall Plugs (not supplied) for No.10 Fixing Screws (supplied).
- 1.4 The Thermostatic Mixing Valve is supplied for rising supplies. For Falling or Rear Entry supplies loosen the Elbow Grubscrew and rotate the Elbow to the required position. Then secure with the Grubscrew.
- 1.5 Fit the supply pipework (Hot - Left, Cold - Right).

Caution! It is essential at this point that the supply pipework is thoroughly flushed through before connection to the Thermostatic Mixing Valve. Failure to do so may result in product malfunction.

- 1.6 Locate the Thermostatic Mixing Valve onto the pipework and secure to the Wall Bracket with the Grubscrew.
- 1.7 Tighten the Compression Nuts and Olives using a suitable spanner.
- 1.8 Install the Shower Fittings, refer to your Shower Fittings Installation and User Guide.
- 1.9 Turn on the hot and cold water supplies and check for leaks.

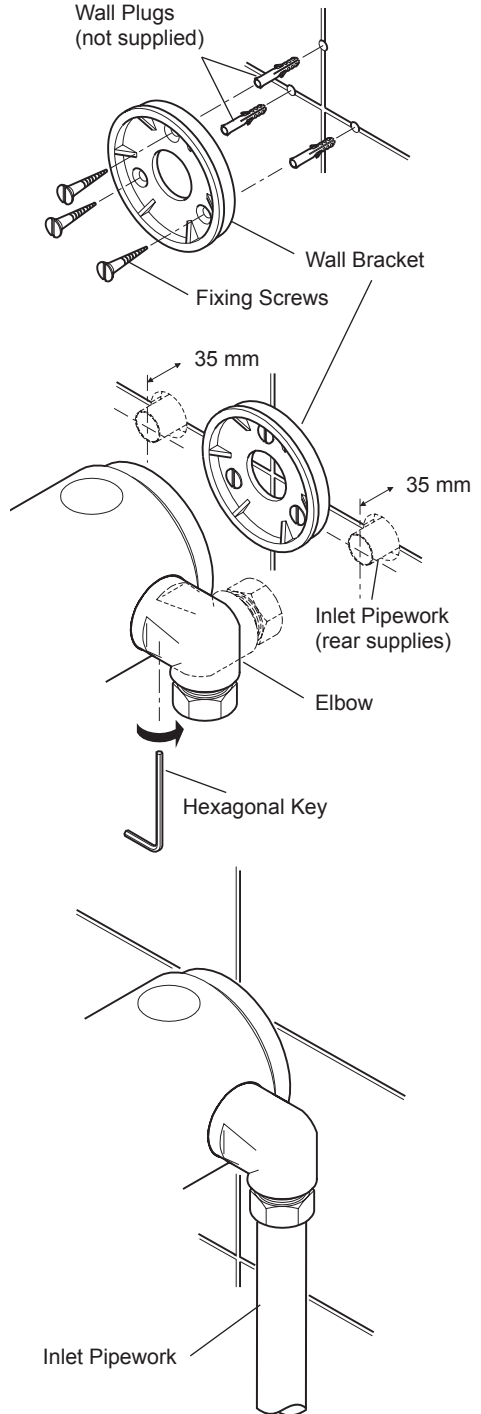

2. Built-in Models

- 2.1 Decide on a suitable position for the Thermostatic Mixing Valve where all users can operate it.
- 2.2 Determine the routes of the incoming hot and cold supply pipework. They can be rising or falling supplies.
- 2.3 Determine the route for the outlet pipework. When connecting the Shower Fittings to the outlet they should be to the side and above the Thermostatic Mixing Valve to make sure that the Flexible Hose hangs correctly and does not obstruct the Shower Control. The outlet can be sited on the right or on the left, as site dictates.
- 2.4 Mark suitable routes for inlet and outlet pipework.
- 2.5 Cut away plasterboard and brick work to a depth of between 60 mm to 80 mm. Depth should be 67 mm min / 87 mm max including finish wall thickness (tiles or facia board).
- 2.6 Fit the supply pipework (Hot - Left, Cold - Right).
Caution! It is essential at this point that the supply pipework is thoroughly flushed through before connection to the Thermostatic Mixing Valve. Failure to do so may result in product malfunction.
- 2.7 Fix the Thermostatic Mixing Valve to the wall or timber noggin (refer to section: '1. Exposed Models' and follow instructions 1.2 and 1.3).
- 2.8 Make the connections to the inlets and outlet of the Thermostatic Mixing Valve as shown
- 2.9 Tighten the Compression Nuts and Olives using a suitable spanner.
- 2.10 Turn on the hot and cold water supplies and check for leaks.

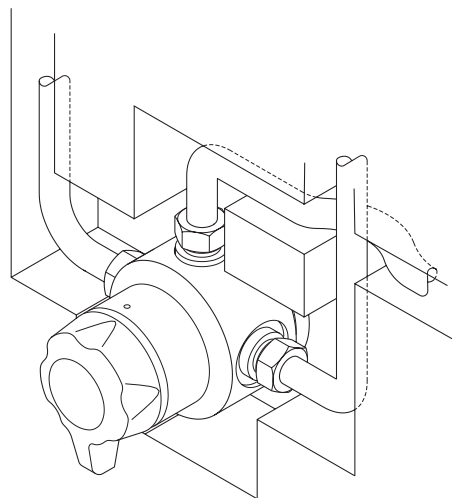
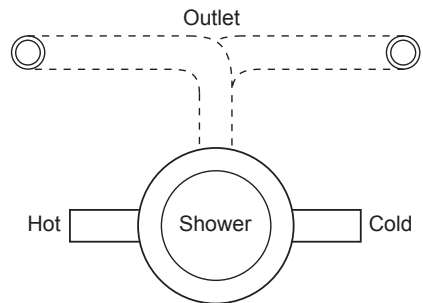
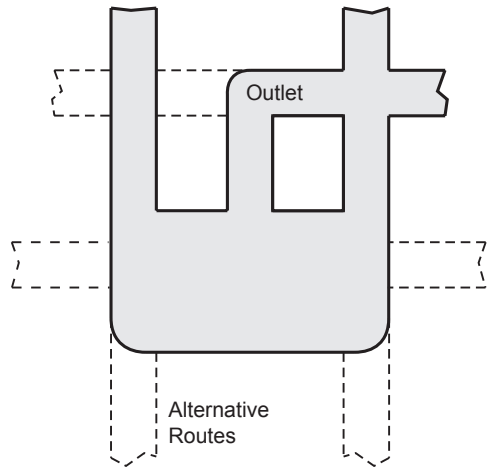

2.11 Plaster and tile up to the Thermostatic Mixing Valve, leaving a maximum diameter hole around the Mixing Valve of 125 mm.

2.12 Fit the Sealing Grommet to the inner diameter of the Concealing Plate. Remove the protective backing from one side of the Foam Washer and fix to rear of the Concealing Plate.

2.13 Unscrew the Control Knob Grubscrew and remove the Control Knob.

2.14 Check that the Concealing Plate will cover the installation hole.

2.15 Peel the second protective backing from the Foam Washer and fit over the Thermostatic Mixing Valve. Push evenly on the Concealing Plate to make sure that the adhesive backing provides a sufficient seal.

2.16 Refit and secure the Control Knob.

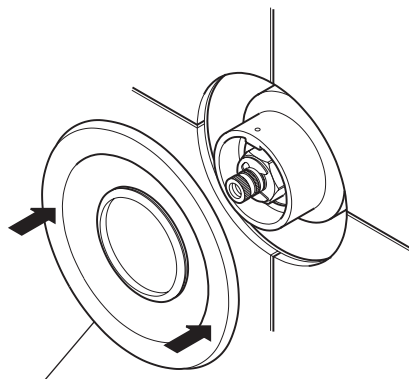
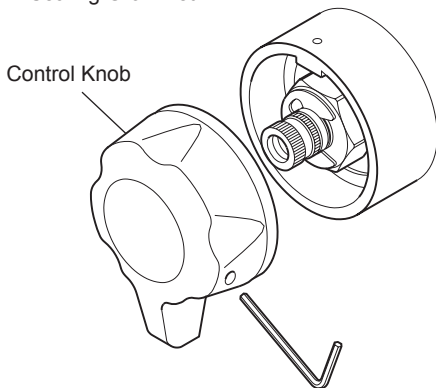
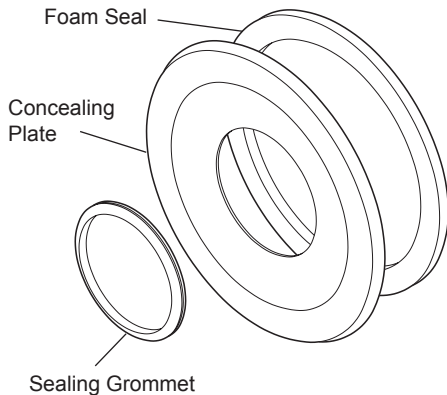

Concealing Plate
(apply pressure evenly)

COMMISSIONING

Commissioning must be carried out in accordance with these instructions, and must be conducted by designated, qualified and competent personnel.

Exercising the Thermostat

Thermostatic Mixing Valves are inclined to lose their responsiveness if not used. Valves which have been in storage, installed but not commissioned, or simply not used for some time should be exercised before setting the maximum temperature or carrying out any tests.

A simple way to provide this exercise is:

- (a) make sure that the hot and cold water are available at the valve inlets, and the outlet is open.
- (b) move the temperature control rapidly from cold to hot and hot back to cold several times, pausing at each extreme.

Commissioning Checks

(Temperatures should always be recorded using a thermometer with proven accuracy)

1. Check the inlet pipework temperature for correct function of the checkvalves.
2. Operate the Meynell V8/3 and check:
 - Flow rate is sufficient for purpose
 - Temperature obtainable is acceptable
 - All connections are watertight.
3. It is advisable to establish a performance check at this time, which should be noted for future reference as part of a Planned Maintenance Program (a Maintenance Record Card has been provided with this Manual).

The procedure should be chosen to imitate both typical and difficult operating conditions, such as any supply pressure fluctuations that may be likely. An ideal method is to locate another outlet on the common cold water supply close to the Thermostatic Mixing Valve (operating this outlet should cause a drop in supply pressure), and note the subsequent effect on blend temperature. This should be no more than 2°C change).

Note! Causing thermal shutdown of the Meynell V8/3 by full closure of the cold supply may not adequately indicate the practical capability of the Meynell V8/3, nor its service condition. Consequently this is not a recommended performance check, and repeated such testing may ultimately affect service life.

Maximum Temperature

The maximum blend temperature obtainable by the user should be limited, to prevent accidental selection of a temperature that is too hot.

The Meynell V8/3 is fully performance tested, and the maximum temperature is preset to approximately 42°C under ideal installation conditions at the factory.

Site conditions and personal preference may dictate that the maximum temperature has to be reset following installation.

Maximum Temperature Setting

Make sure that an adequate supply of hot water is available at the hot inlet of the Meynell V8/3 and that both inlet isolating valves are fully open.

The minimum temperature of the hot water must be at least 10°C above the desired blend, however during resetting this should be close to the typical storage maximum to offset the possibility of any blend shift due to fluctuating supply temperatures.

1. Turn on the Thermostatic Mixing Valve to its maximum setting, (for Lockshield models turn on the separate outlet device fitted eg. stopvalve). Let the temperature stabilise.
2. Unscrew the Control Knob Grubscrew and remove the Control Knob or Lockshield.
3. Insert the 2.5 mm hexagon key into the centre of Mixing Valve Head.
4. Turn the hexagon key anticlockwise to increase the temperature, or clockwise to decrease temperature.
5. Refit and secure the Control Knob or Lockshield and turn off the Thermostatic Mixing Valve (on lockshield models turn off the outlet device).

Note! The Control Knob should be fitted with the 'brand' horizontal.

Note! For Lockshield models make sure that the anti-rotation slots are engaged on the Lug on the Mixing Valve Body (refer to arrow on illustration).

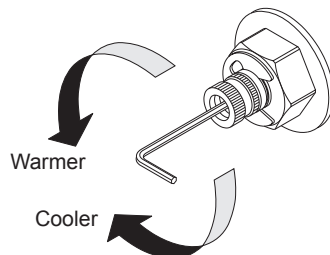
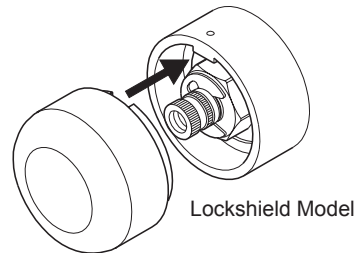
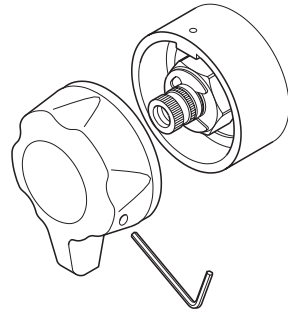

OPERATION

Temperature selection (not lockshield model).

The mixer has one control to set temperature and works in a sequence:

Off → Cold → Tepid → Pre-set Maximum

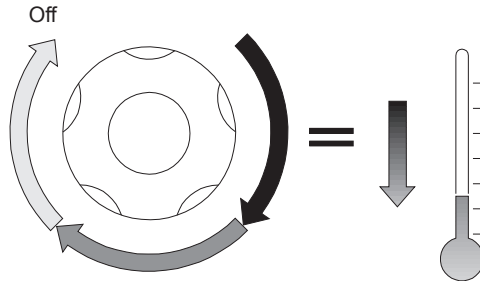
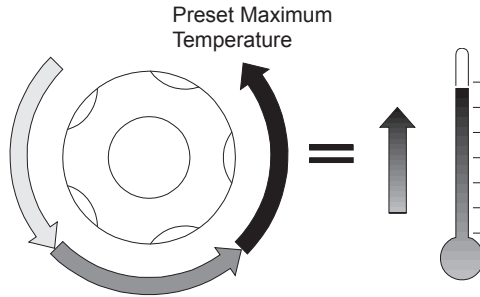

FAULT DIAGNOSIS

Symptom	Cause/Rectification
1. Only hot or cold water from mixer outlet.	<ul style="list-style-type: none"> a. Inlet supplies reversed (hot supply to cold supply). b. No hot water reaching mixer. c. Check strainers and inlet/outlet fittings for blockage. d. Installation conditions continuously outside operating parameters, refer to section: 'Specifications' and 2.e below.
2. Fluctuating or reduced flow rate.	<p>Normal function of the thermostatic control when operating conditions are unsatisfactory.</p> <ul style="list-style-type: none"> a. Check strainers and inlet/outlet fittings for blockage. b. Make sure minimum flow rate is sufficient for supply conditions. c. Make sure the maintained inlet pressures are nominally balanced and sufficient. d. Make sure the inlet temperatures differentials are sufficient. e. (Subsequent to rectification of supply conditions) Check thermostatic performance; renew Piston Assembly if necessary.
3. No flow rate from mixer outlet.	<ul style="list-style-type: none"> a. Check strainers and inlet/outlet fittings for blockage. b. Hot or cold supply failure.
4. Blend temperature drift.	<p>Indicates operating conditions changed.</p> <ul style="list-style-type: none"> a. Refer to symptom 2. above. b. Hot supply temperature fluctuation. c. Supply pressures fluctuating. d. Seal damage or wear. Renew seals.
5. Maximum blend temperature setting too hot or too cold.	<ul style="list-style-type: none"> a. Indicates incorrect maximum temperature setting; refer to section: 'Commissioning'. b. As symptom 4. above.
6. Water leaking from mixer body.	<p>Seal wear or damage.</p> <ul style="list-style-type: none"> a. Obtain Seal Kit, renew all seals.
7. Flow rate too high or too low.	<ul style="list-style-type: none"> a. (Too low) Refer to symptom 2.a-e. above. b. (Too low) Insufficient supply pressures. c. (Too high) Supply pressure too high. d. (Too high) Refer to symptom 2.a-e. above.

MAINTENANCE

General

1. The maintenance of this product must be carried out in accordance with the instructions given in this manual, and must be conducted by designated, qualified and competent personnel.
2. Meynell products are precision-engineered and should give continued superior and safe performance, provided:
 - They are installed, commissioned, operated and maintained in accordance with the recommendations stated in this product manual.
 - Periodic attention is given as necessary to maintain the product in good functional order.
3. The use of main supply-line or zone strainers (recommended maximum mesh aperture dimension is 0.5 mm) will reduce the need to remove debris at each Mixing Valve point.

Lubricant

Important! All seals are pre-lubricated. If you need to lubricate the seals, use only a small amount of silicon-only based lubricants on this product. Do not use oil-based or other lubricant types as these may cause rapid deterioration of seals.

Cleaning

Warning! Many household and industrial cleaning products contain mild abrasives and chemical concentrates, and should not be used on polished, chromed or plastic surfaces.

PLANNED MAINTENANCE

Malfunction of the valve is almost always progressive in nature and will be detected by the use of proper temperature checking and maintenance routines.

Certain types of system can result in the valve having excessive 'dead-legs' of pipework, or auxiliary cold water supply added to the mixed water from the mixing valve. Such systems can disguise the onset of thermostatic mixing valve malfunction and should not be used.

We recommend a preventative maintenance procedure based on site conditions and the risk to the user. All results must be recorded in a log book.

Healthcare

Healthcare applications are hospitals, aged person facilities, residential care homes, etc. and any other applications where the user is similarly at risk.

Ultimately, the user or attendant must exercise diligence to make sure that the delivery of warm water is at a stable, safe temperature. This is particularly important in such procedures as supervised bathing where patients are unable to respond immediately to unsafe temperatures.

Irrespective of supply and usage conditions or the evidence of in-service tests, critical components should be replaced at intervals of no more than 5 years.

Note! During the replacement of critical components, it may be necessary to replace other non-critical components.

Frequency of In-service Tests

Healthcare

Follow the procedure detailed in the flow diagram "In-service Test Procedure". This procedure must be followed 6 to 8 weeks after commissioning and 12 to 15 weeks after commissioning. The recorded blend temperature (T_b) from these two tests will determine the maximum frequency for future service intervals.

Result of 6-8 week tests	Result of 12-15 week tests	Next service interval
< 1 °C	< 1 °C	9 - 12 weeks
> 1 °C	< 1 °C	9 - 12 weeks
< 1 °C	> 1 °C	9 - 12 weeks
> 1 °C	> 1 °C	6 - 9 weeks

The subsequent in-service test results should be used as a guide, in conjunction with a suitable risk assessment, to determine the schedule of future in-service tests.

More regular temperature checks should be made where increased risks are perceived, i.e. patients are unable to immediately respond to an increase in water temperature, by either shutting the water off or removing themselves from contact with the water.

Maintenance personnel should also make sure that the staff are aware of the importance of reporting temperature variations and when detected, these should be recorded in the Log Book.

Commercial

Check for correct blend setting every 6 months.

Follow the procedure detailed in the flow diagram “In-service Test Procedure”, every 12 months.

Checkvalves and Filters

Isolate the supplies to the valve and operate the valve to release pressure and to assist the draining of residual water.

The checkvalve cartridge assembly may be removed for cleaning. Inlet strainers can be flushed through under a jet of water to remove any lodged particles.

Note! The checkvalve cartridge is not a serviceable item, so any apparent wear or damage will require its renewal. Lightly wipe external seals of the new checkvalve with a silicone-only based lubricant to assist in refitting.

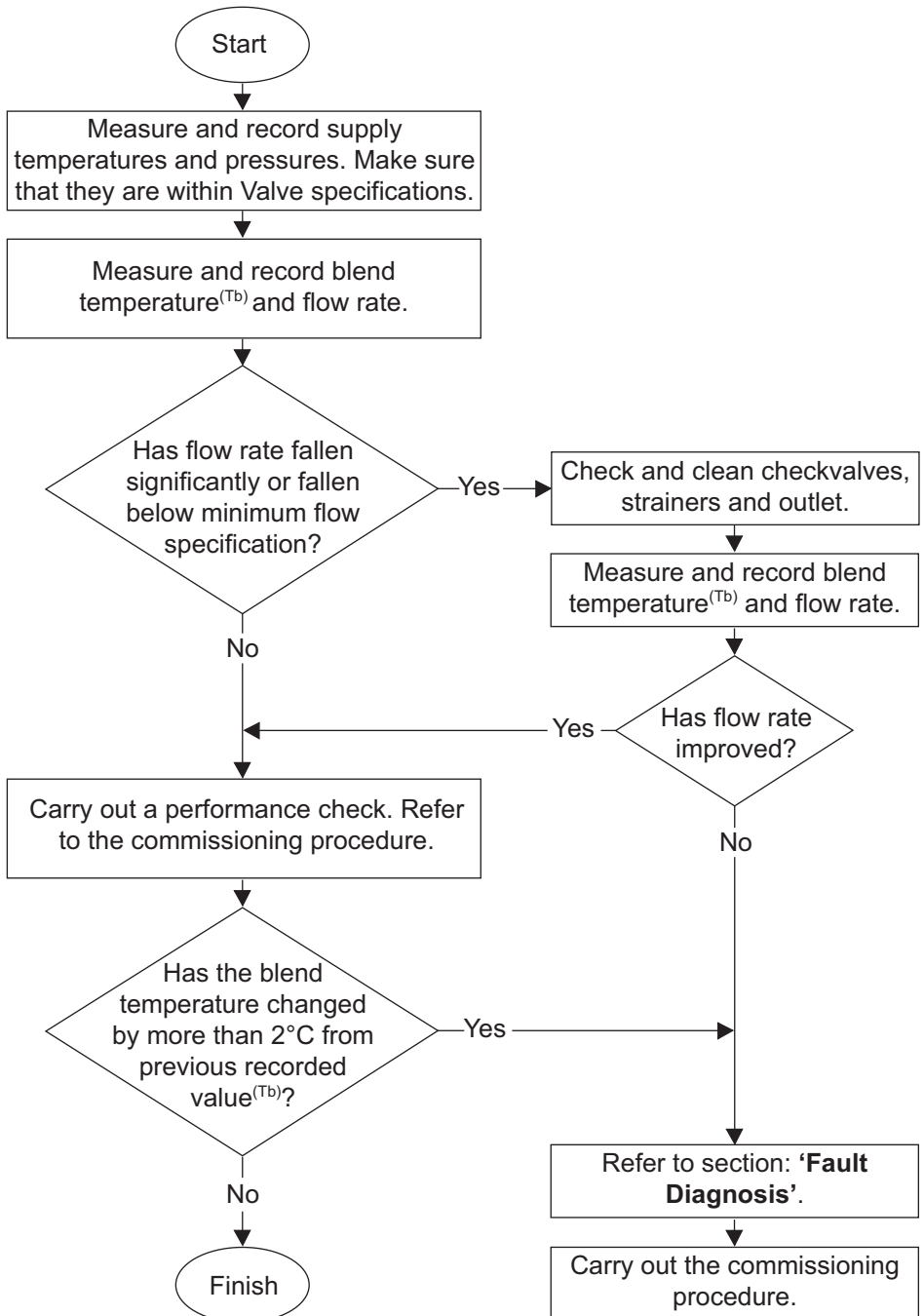

Note! All measurements and results should be recorded in the Log Book.

Flow Diagram, In-service Test Procedure

TYPE 2 AND TYPE 3 VALVES

Application

The approved designations for Type 2 Valves are as follows:

Model	Designation
Meynell V8/3	HP-S, HP-W, LP-S, LP-W

The permitted application details are:

Designation	Operating Pressure Range	Application	Mixed Water Temperature†°C
-HP-S	High Pressure	Shower	41°C maximum
-HP-W	High Pressure	Washbasin	41°C maximum
-LP-S	Low Pressure	Shower	41°C maximum
-LP-W	Low Pressure	Washbasin	41°C maximum

The approved designations for Type 3 Valves are as follows:

Model	Designation
Meynell V8/3	HP-S, HP-W, LP-S, LP-W

The permitted application details are:

Designation	Operating Pressure Range	Application	Mixed Water Temperature†°C
-HP-S	High Pressure	Shower	41°C maximum
-HP-W	High Pressure	Washbasin	41°C maximum
-LP-S	Low Pressure	Shower	41°C maximum
-LP-W	Low Pressure	Washbasin	41°C maximum

† Mixed water temperature at discharge point.

Note! For washbasins, it is assumed that you are washing under running water.

In order to achieve the safe water temperatures expected of a Type 3 valve it is essential that the valve is used only for the applications covered by its approved designations, with the appropriate water supply pressures and temperatures, and it is commissioned, maintained and serviced in accordance with the recommendations contained in this guide.

Installation Conditions

For healthcare applications where a Type 2 or Type 3 valve is required, the supply conditions must comply with the values in the following table. Note that both supply pressures must lie within the same pressure range.

Operating Pressure Range	High Pressure	Low Pressure
Maximum Static Pressure - bar	10	10
Maintained Pressure, Hot and Cold - bar	1 to 5	0.2 to 1
Hot Supply Temperature - °C	52 to 65	52 to 65
Cold Supply Temperature - °C	5 to 20	5 to 20

Valves operating outside these conditions cannot be guaranteed to operate as Type 2 or Type 3 Valves.

Commissioning

(Temperatures should always be recorded with a thermometer with proven accuracy)

1. Check that the designation of the Thermostatic Mixing Valve matches the intended application.
2. Check that the supply pressures are within the range of operating pressures for the designation of the Valve.
3. Check that the supply temperatures are within the range permitted for the Valve and by guidance information on the prevention of legionella etc.
4. Check inlet pipework temperatures for correct function of the Checkvalve.
5. All connections and Mixer Body are water tight.
6. Operate the outlet flow control and check:
 - (a) Flow rate is sufficient for purpose.
 - (b) Temperature(s) obtained are acceptable.
7. Exercise the Thermostat (refer to section: '**Commissioning**', **Exercising the Thermostat**').

8. Adjust the temperature of the mixed water in accordance with the instructions in this manual and the requirement of the application and then carry out the following sequence:
- (a) record the temperature, and pressures if possible, of the hot and cold water supplies.
 - (b) record the temperature and flow rate of the mixed water at the largest draw-off flow rate.
 - (c) record the temperature and flow rate of the mixed water at a smaller draw-off flow rate.
 - (d) isolate the cold water supply to the mixing valve and monitor the mixed water temperature.
 - (e) record the maximum temperature achieved as a result of (d) and the final temperature.
- Note!** The final mixed water temperature should not exceed the values shown in the following table. Any higher temperatures should only occur briefly.
- (f) record the date, equipment, thermometer etc. used for the measurements.

Application	Mixed Water Temperature°C
Bidet	40
Shower	43
Washbasin	43
Bath (44°C Fill)	46
Bath (46°C Fill)	48

Maintenance

Planned maintenance for Type 3 valves must use the In-service test, at the frequency given in the Guide to In-service test frequency and should employ Temperature Testing, Performance Log books and Training, refer to section: '**Planned Maintenance**'.

Type 2 valves must use the 'In-Service Test' at a frequency of not more than one year.

SPARE PARTS

SPKB0016P	Control Knob (Stub Lever)
SPLR0012P	Control Knob (Long Lever)
SPSL0006J	Cartridge Sleeve Assembly - Components identified 1
SPPE0007P	Concealing Plate (Chrome)
SPSK0319.1J	V8 Seal Kit - Components identified 'A'
147.48	Non Return Valve (Lockshield Only) - Not Illustrated
457.04	Bezel
1551.184	Lockshield Knob
1551.185	Backplate
1551.186	Inlet Elbow Pack
1551.187	Inlet Connector Pack (B model)
1551.188	Outlet Connector Pack - Components identified 'B'

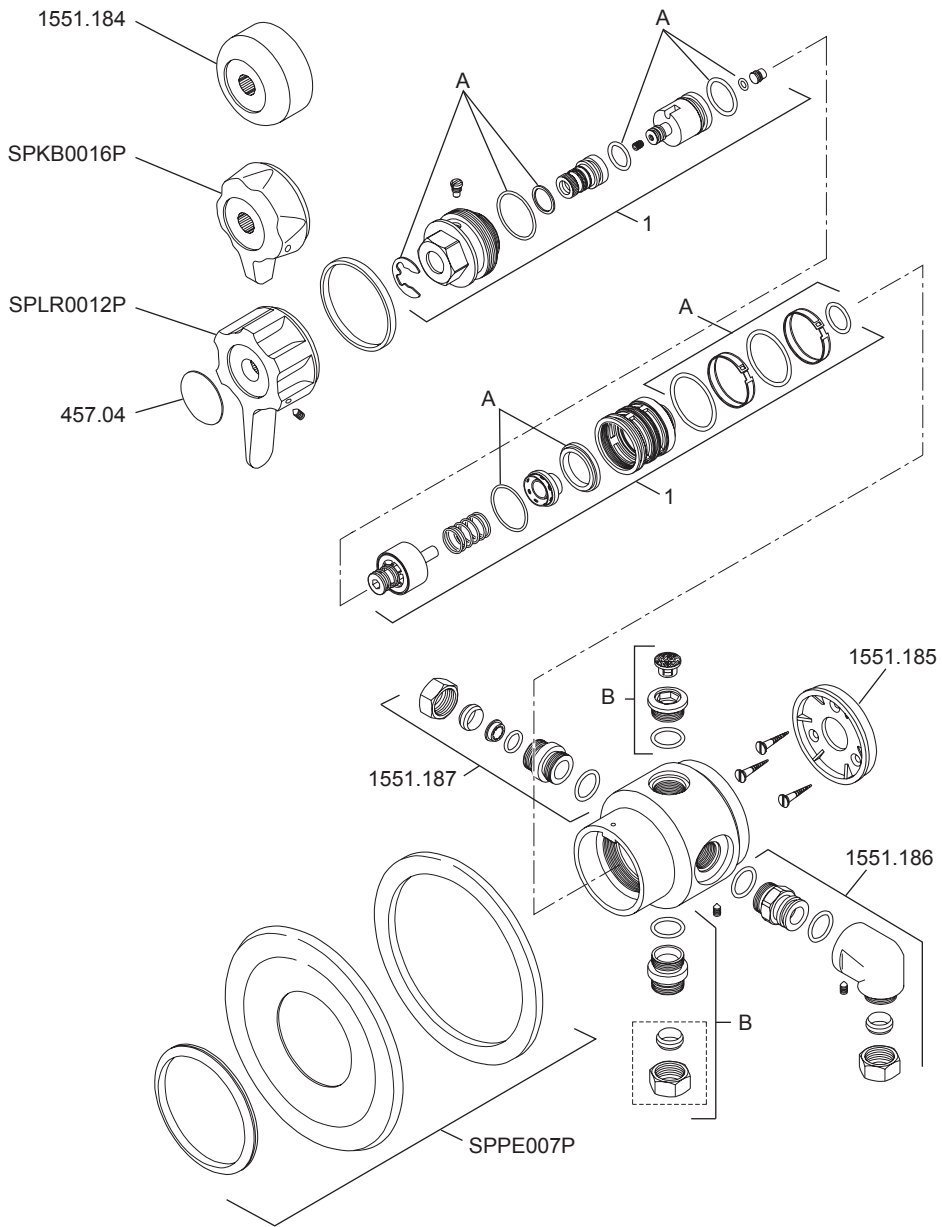

NOTES

NOTES

CUSTOMER CARE

Guarantee

Kohler Mira Ltd. guarantee this product against any defects in materials or workmanship for a period of one year from the date of purchase.

To be covered by this guarantee, service work must only be undertaken by Kohler Mira Ltd. or approved agents.

Not covered by this guarantee

Defects or damage arising from incorrect installation, improper use or failure to maintain in accordance with the instructions in the product manual, including the build-up of limescale.

Defects or damage if the product is taken apart, repaired or modified by a person not authorised by Kohler Mira Ltd. or approved agents.

After Sales Service - how we can help you

We have a network of fully trained staff ready to provide assistance, should you experience any difficulty operating your Meynell equipment.

Spare Parts

All functional parts of Meynell products are kept for up to ten years from the date of final manufacture.

If during that period, our stock of a particular part is exhausted we will, as an alternative, provide an equivalent new product or part at a price equating to the cost of repair to the old, bearing in mind the age of the product.

Customer Care Policy

If within a short time of installation the product does not function correctly, first check with the operation and maintenance advice provided in this Manual to see if the difficulty can be overcome.

Failing this, contact your installer to make sure that the product has been installed and commissioned in full accord with our detailed installation instructions.

If this does not resolve the difficulty, please ring your nearest Meynell contact who will give every assistance and, if appropriate, arrange for the local service engineer or Agent to call on a mutually agreeable date.

Contact:

Meynell Valves

Cromwell Road,
Cheltenham,

England, GL52 5EP, UK.

Telephone: +44 (0)870 600 0221

Fax: +44 (0)1242 221925

SPECIFICATION ENQUIRIES

Telephone: +44 (0)1242 282527

Fax: +44 (0)1242 282404

E-Mail: rada_technical@mirashowers.com



Meynell is a registered trade mark of
Kohler Mira Limited.

The company reserves the right to alter
product specifications without notice.

www.radacontrols.com



FM 14648