

RADA 222-T3 DK THERMOSTATIC MIXING VALVE



- Features the unique Patented “Radatherm” service-free cartridge
- Unbeatable temperature control
- Complete with check valves and strainers



Specify as: Rada 222-t3 dk (1.0.407.07.3)

$\frac{3}{4}$ " thermostatic mixing valve incorporating Radatherm service-free cartridge, check valves and strainers. Supplied with $\frac{3}{4}$ " flat faced union connectors terminating in 22 mm compression connections.

Dimensions (mm)

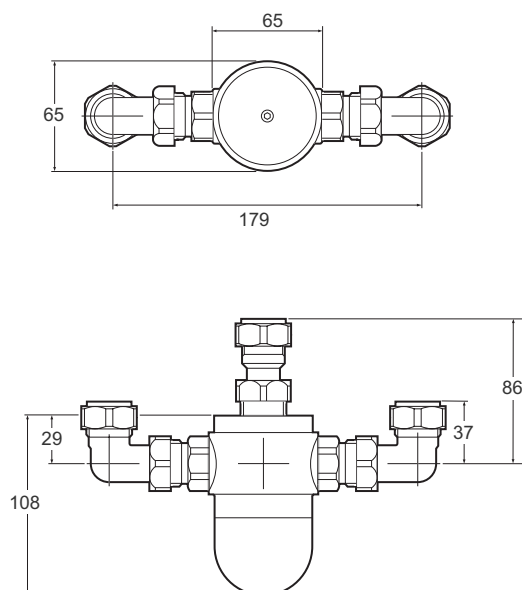

Flow Diagram

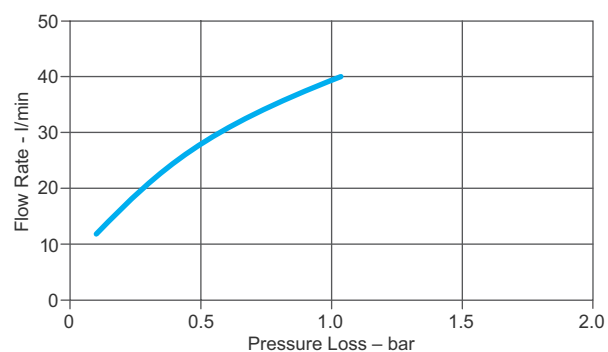

Kohler Mira Limited
Cromwell Road
Cheltenham
Gloucestershire
GL52 5EP

Specification Enquiries
Tel: 0844 571 1777
Fax: 0844 472 3076
Email: rada_technical@mirashowers.com
www.radacontrols.com

TECHNICAL SPECIFICATION

Installation and Maintenance

Please refer to the appropriate Product Manual.

Connections

Inlet and Outlets: ¾" flat-faced male union.

Note! 2 elbows and 1 straight union connectors are supplied, terminating in 22 mm compression connections.

Standard connections are **hot** (left), **cold** (right).

Approvals

Buildcert TMV3 Thermostatic Mixing Valve Scheme approved:

LP-T44 - Low Pressure Bathfill up to 44°C

LP-T46 - Low Pressure Bathfill up to 46°C (assisted)

HP-T44 - High Pressure Bathfill up to 44°C

HP-T46 - High Pressure Bathfill up to 46°C (assisted)

Certificate No: ETC/15/0597.

Complies with the technical requirements of BS7942 for the same designations.

Designed to comply with European Standards EN1111 and EN1287.

WRAS approved (Water Regulations Advisory Scheme).

Designed, manufactured and supported in accordance with accredited

BS EN ISO 9001:2008 Quality Management Systems and

BS EN ISO 14001:2004 Environmental Management Systems

Operation

The Rada 222-t3 dk is designed to be concealed in a duct/cupboard and must be used with a separate outlet flow control such as a tap.

Materials

Body: DZR brass nickel plated.

Locking Shroud: White engineering plastic.

Temperature Range

Factory pre-set maximum outlet temperature: 43°C.

Minimum temperature differential, blend to either supply: 12°C.

Optimum thermostatic control range: 30 °C - 50 °C.

Minimum cold water temperature: 1°C.

Maximum hot water temperature: 85 °C.

Note! The mixing valve can accept temporary temperature excursions above 85°C without damage, however, operation of the mixing valve at such elevated temperatures is not recommended. For reasons of general safety, hot water storage supply temperatures should ideally be maintained at between 60°C - 65°C where serving ablutionary applications.

Pressures/Flow Rates

Minimum dynamic supply pressure: 0.15 bar.

Minimum flow rate: 3 l/min at mid blend.

Maximum flow rate: 40 l/min at mid blend (which equates to a maximum pressure loss of 1.2 bar).

Maximum pressure loss ratio*: 10:1 (in favour of either supply).

Maximum dynamic supply pressure: 5 bar.

Maximum static pressure: 10 bar.

Note! Both hot and cold pressure should be nominally equal.

* Pressure loss ratio is determined by subtracting the resistance to flow of the outlet pipework and outlet fittings (generally known as 'back pressure', and measured at the outlet of the mixing valve) from the dynamic pressures of the hot and cold water at the inlets of the mixing valve. This is at its extreme when the mixing valve is being used at its lowest flow rate and when the maximum inequality occurs in the pressure of the hot and cold water supplies.

Weight

Product	Gross Weight (Kgs)	Total Packaged Weight (Kgs)
Rada 222-t3 dk	1.900	2.044

Kohler Mira Limited
Cromwell Road, Cheltenham
Gloucestershire, GL52 5EP

Specification Enquiries

Tel: 0844 571 1777, Fax: 0844 472 3076
Email: rada_technical@mirashowers.com
www.radacontrols.com

Rada is a registered trademark of Kohler Mira Limited.

The company reserves the right to alter product specification without notice.

© January 2012 Kohler Mira Limited. All rights reserved.

No part of this document, or any accompanying document, may be reproduced or transmitted in any form or by any means, including photocopying or electronically, without the permission of Kohler Mira Limited.

A **KOHLER** COMPANY



FM 14648

