



4+



12



2,8m



1 = 10,12m 2 = 7,14m 3 = 3,2m

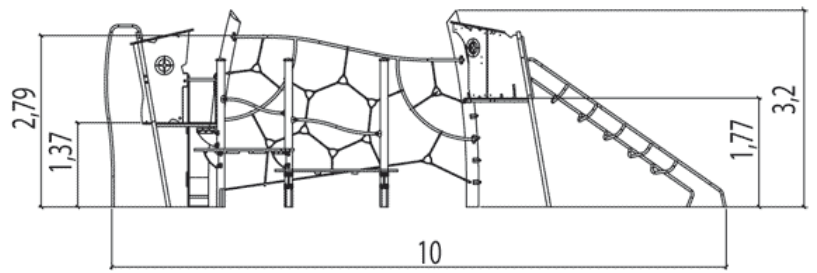
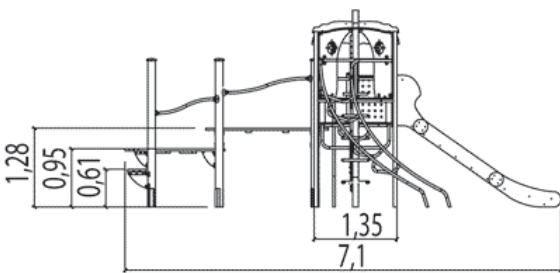
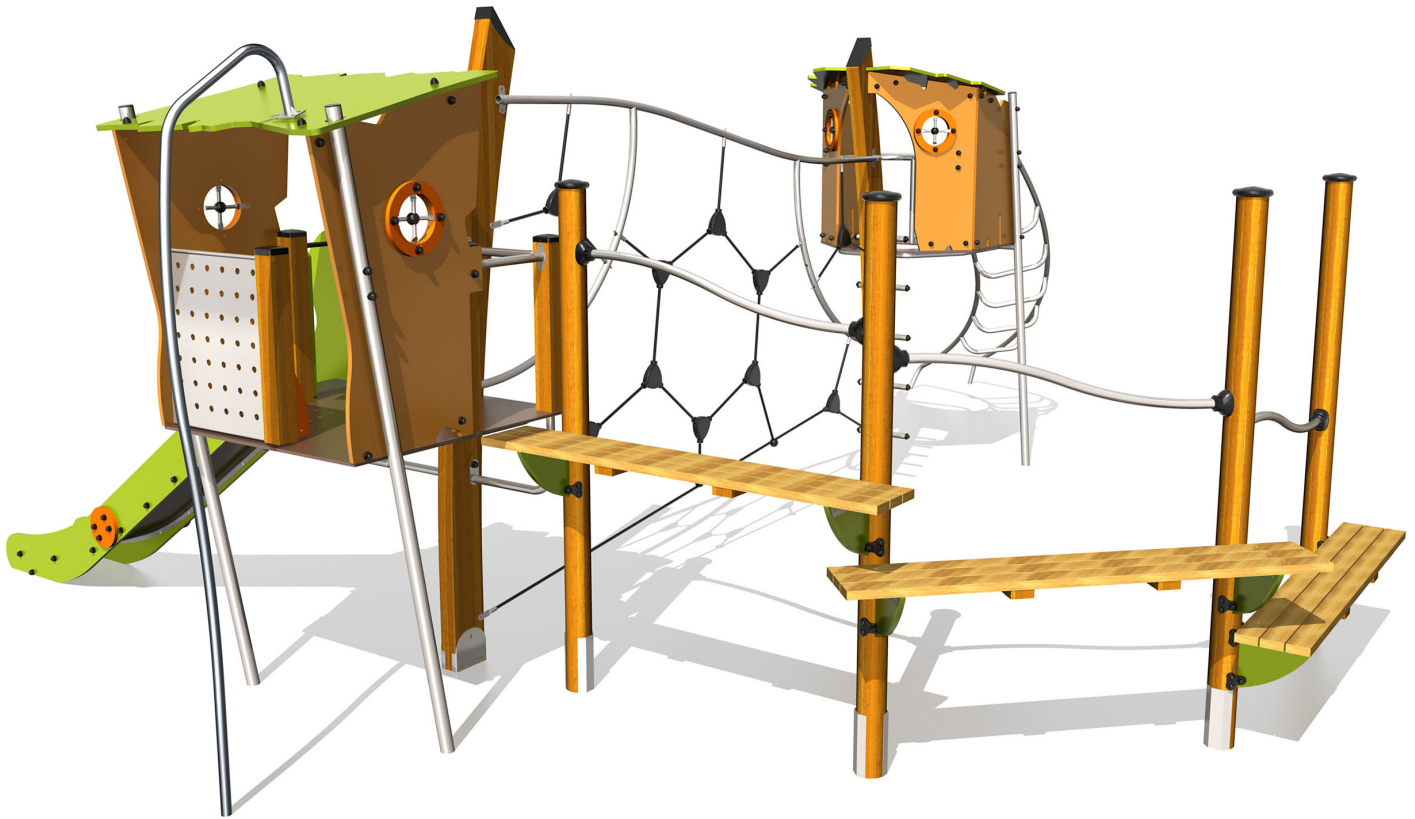

## Play value

sliding



x3

climbing



x1

getting across



x1

meeting / role play



x2

Number of play elements: 7

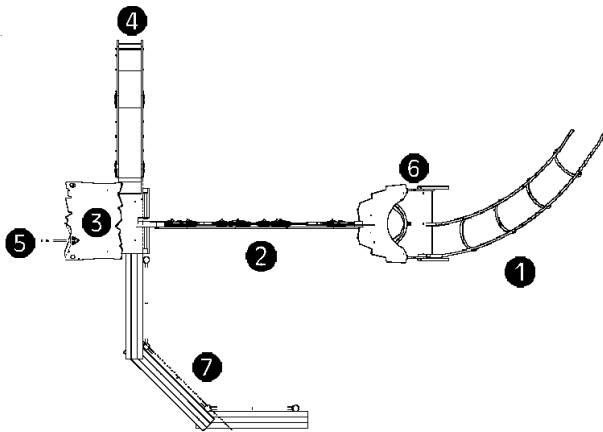

- ① Torrent
- ② Spider's web
- ③ The fisherman's hut HT: 1.37m
- ④ Slide HT: 1.37m
- ⑤ Fireman's pole HT: 1.37m
- ⑥ The owl's hut HT: 1.77m
- ⑦ The footpath

## Installation of equipment

Impact area =

- Impact area
- Free space

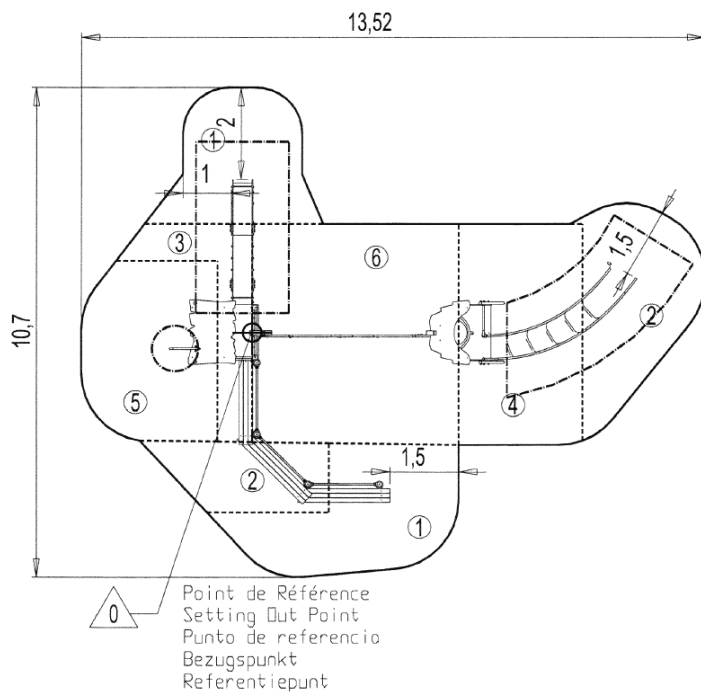

1	1,00m	18m <sup>2</sup>
2	1,30m	15m <sup>2</sup>
3	1,37m	5m <sup>2</sup>
4	1,77m	13m <sup>2</sup>
5	2m	11m <sup>2</sup>
6	2,8m	22m <sup>2</sup>



2



22h45



0.6m<sup>3</sup>



84m<sup>2</sup>



690kg



33kg

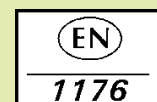

*Proludic*

2014-06-30