



1000FR series

Fire Rated Metal Access Panels for Ceilings and Walls

2 HOUR FIRE RATED (2FR)



KEY FEATURES



INTRODUCTION

The PROFAB 1000 series range of steel lockable access panels provides access into jointless plaster / plasterboard wall / partitions and suspended ceilings, where access to mechanical and electrical services is required.

DESCRIPTION

COMPOSITION & MANUFACTURE

The 1.2mm thick, electro-galvanised mild steel frame holds a flush 1.2mm thick, electro-galvanised mild steel flush faced door (MD) through a simple concealed pivot hinge device. The door is held closed with a concealed lock and opens towards the user. Doors are removable if damage occurs or during installation. Panels are powder coat finished all over, a constant 2mm gap is maintained between the door and frame.

1000/BF/BL

Frame: 1.2mm thick, electro-galvanised mild steel, incorporating a simulated dry wall edge bead profile (BF). Factory welded to specified size and finished white powder coated primer.

Door: 1.2mm thick, electro-galvanised mild steel flush faced tray finished white powder coated primer.

Locks: Concealed budget lock on the rear of the door, operated from the front face with an 8mm square drive key (included). A white, round removable cap on the door face conceals the keyhole.

1000/PF/BL

All as above option but finished all-over in white powder coated matt RAL 9010.

TYPICAL SIZES

Dim X	Dim Y
200mm	200mm
300mm	300mm
300mm	600mm
450mm	450mm
550mm	550mm
600mm	600mm
600mm	900mm
600mm	1200mm

All dimensions in millimetres.

All doors hinge along dimension Y.

All panels are single door.

1000FR series panels are available in sizes from 200mm x 200mm to a maximum of 600mm x 1200mm. Contact Profab for details.

KEY POINTS TO NOTE

1. X and Y dimensions are outside rear frame.
2. Overall frame depth is 45mm (Add a further 7mm at localised Budget lock position).
3. Structural opening required for installation is (X+5) x (Y+5).
4. Clear available access when installed, with door in the open position is (X-70) x (Y-50).

CEILING



WALL



FRAME OPTIONS



Beaded Frame (BF)

Picture Frame (PF)



Deep Plaster Frame (DPF)

LOCK OPTIONS

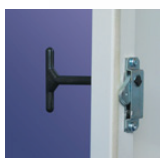

Budget Lock (BL)

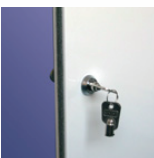

Security Lock (SL)

TYPICAL CEILING DETAILS (MF ceiling)

All support angles, channels and fixings by contractor unless stated otherwise.

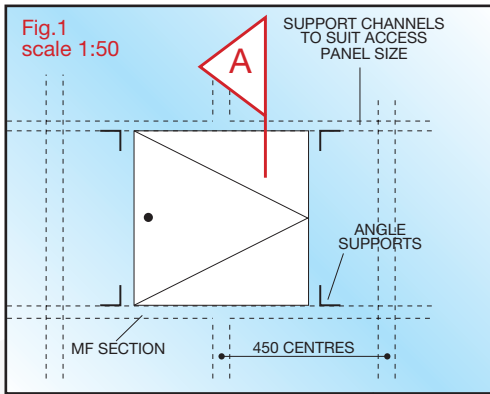
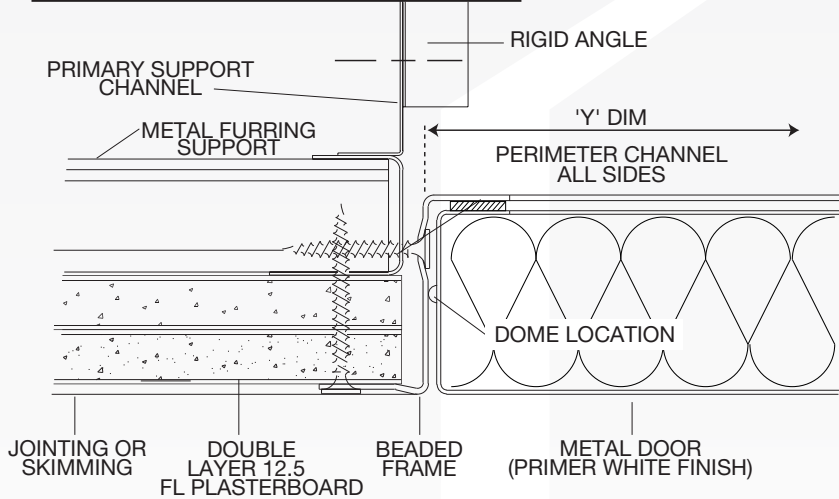

Fig.2 scale 1:2 section on **A**



TYPICAL WALL DETAILS (masonry and dry-wall)

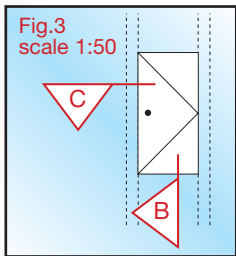

Fig.4 scale 1:2 section on **B**

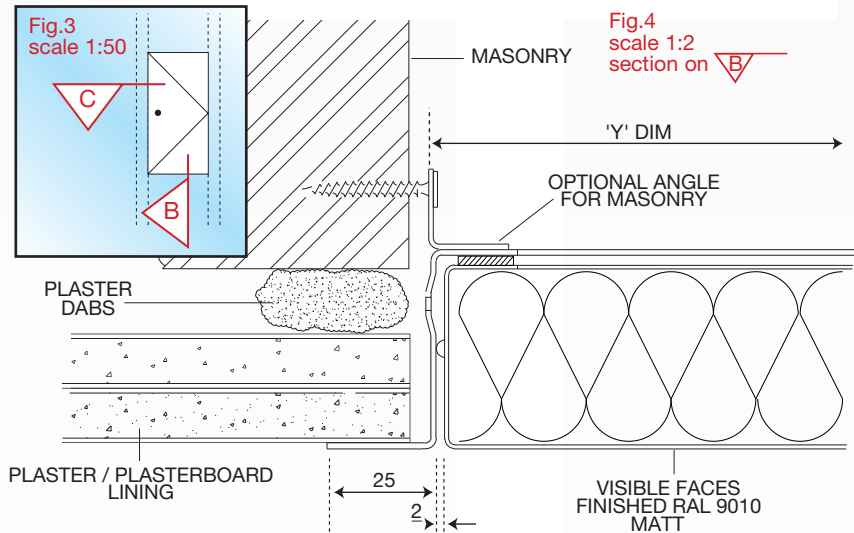
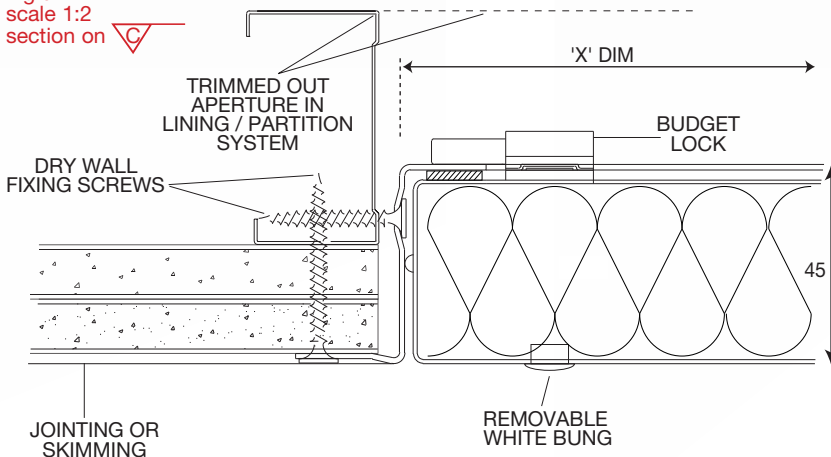

Fig.5 scale 1:2 section on **C**



APPLICATIONS & USES

All standard panels are for internal use and only in areas of normal humidity. Factory supplied standard finish white matt powder coated, other colours & finishes are available upon request.

1000/BF/BL is suitable for vertical or horizontal use where the panel is being installed prior to any tape and jointing or skim-coat plastering.

1000/PF/BL is suitable for vertical or horizontal use where the panel is being installed after all finishing work has been completed.

SPECIFICATIONS

EXAMPLE:

Access panel type 1000/BF/BL. Size 600 x 600mm single door unit supplied by Profab Access Ltd.

OTHER OPTIONS

The 1000 series is an entry-level access panel designed to provide a simple, economic means of accessing building services, so only limited modifications are available with this product. However, PROFAB'S manufacturing flexibility provides for alternative sizes, locks and paint colours. Discussions with PROFAB should take place at the earliest opportunity if specification changes are being considered.

INSTALLATION

Apertures formed in dry lined walls and ceilings should be suitably formed and adequately supported to take the additional weight and operating forces exerted during operation. Typical fixing details are shown on this data sheet.

OPERATION

The panel is fitted with a concealed budget lock, operated with a supplied square drive key through a round keyhole in the door face following removal of the white plastic cap (Additional keys and caps are available from PROFAB).

SUPPLY

Available through a network of distributors. Refer to PROFAB for guidance.

TECHNICAL SERVICES

ADVISORY

If there is any doubt about the information given in this data sheet or the intended product usage, then PROFAB should be consulted. We are only too pleased to advise on the use of our products. Technical representation is available at all stages of a project. In-house manufacturing enables us to offer full flexibility in product design for projects that need to meet specific design criteria.

QUALITY & DEVELOPMENT

PROFAB access panels are manufactured under strictly controlled quality systems and so we reserve the right to amend any of our published information and specifications deemed necessary as a part of our continuous product development and improvement policy, without prior notice.

PERFORMANCE (2FR)

120 minutes fire rated. BS EN 1634-1: 2000
30dB acoustic shielded. BS EN ISO 140-3: 1995, BS 2750: Part 3: 1995
Airtight to Part L. BS EN 12207: 2000 & BS EN 1026: 2000
CNC manufactured to ISO 9001:2009.



1000

1000FR series continued . . .

PLEASE CONTACT PROFAB ACCESS OR YOUR NEAREST DISTRIBUTOR FOR FURTHER INFORMATION & SALES

AIS fpdc

UK Design
Manufacture



**Our products are now
available to download
as objects...**

NBS National BIM Library



Distributor:

Profab Access Ltd.
Unit C-D
Riversdale House
Riversdale Road
Atherstone
Warwickshire
UK
CV9 1FA

TEL: +44 (0) 1827 718 222
FAX: +44 (0) 1827 818 680
sales@profabaccess.com
www.profabaccess.com

