

## PFD60 Fire Door Kit

# FITTING INSTRUCTIONS

IF INSTALLING ANY OF THE PORTMAN SELF CLOSING SYSTEMS, PLEASE READ THE CORRESPONDING FITTING INSTRUCTIONS SUPPLIED WITH THE CLOSING SYSTEM FIRST



(Image for reference only)

### SUGGESTED TOOLS



DRILL



G-CLAMP



TAPE MEASURE



HACKSAW



PLUMB LINE



HANDSAW



SPIRIT LEVEL



PROTECTIVE EQUIPMENT

### COMPONENTS

#### POCKER DOOR KIT

- SHORT / LONG 'Z' SECTION \*
- LONG 'Z' SECTION \*
- L-SHAPED TRACK PACKER \*
- PLYWOOD TRACK MOUNT \*
- ALUMINIUM TRACK \*
- DOOR BOTTOM CHANNEL \*
- SOLE PLATE \*
- DOOR SEAL \*

#### DOOR JAMB SET

- HEAD SECTION 2
- FRONT EDGE JAMB 2
- CASSETTE EDGE JAMB 2
- "T" SHAPED JAMB 1
- FIRE RATED BOARD PROFILES 6
- INTUMESCENTS 7

#### SLIDING MECHANISM

- TROLLEY CATCH 2
- TROLLEY ASSEMBLY 2
- FLOOR GUIDE 1

#### FIXING ITEMS

- END BLOCK 1
- PROTECTIVE EDGE CLIP \*
- CHOCK LARGE \*
- CHOCK SMALL \*
- SET A \*
- SET B \*
- SET C \*
- SET D \*
- SET E \*
- SET F \*

\* Quantities are dependant on type of kit ordered

## POCKET DOOR KIT

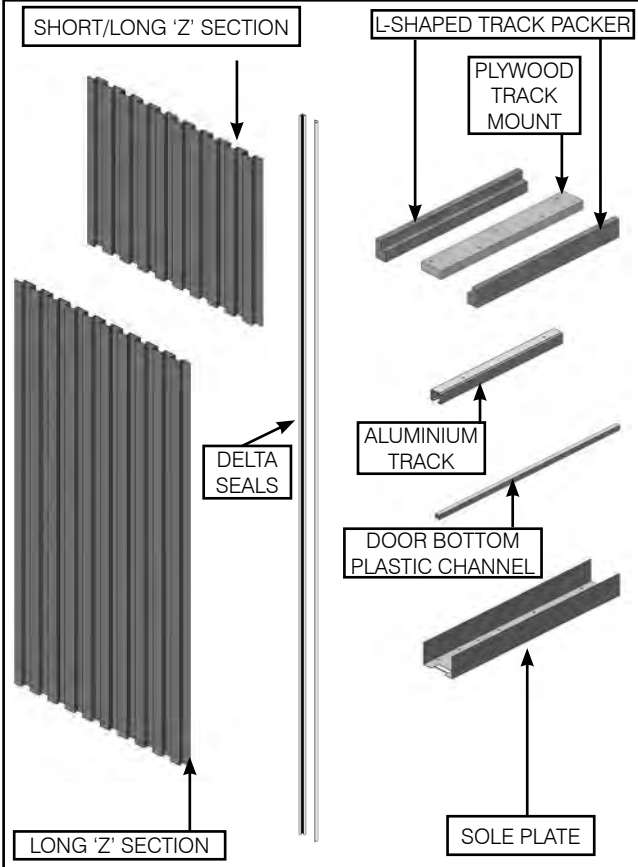

## SLIDING MECHANISM

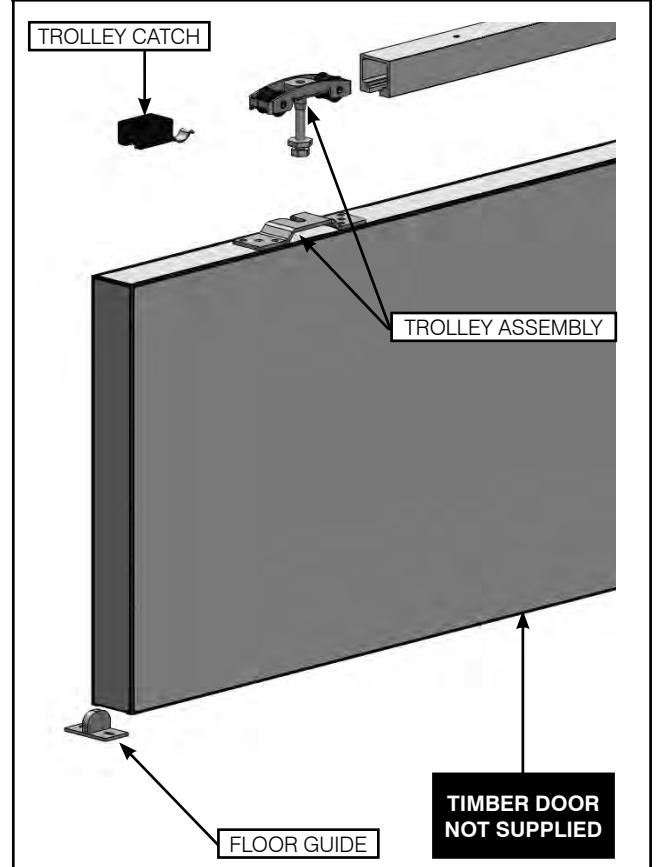

## DOOR JAMB SET

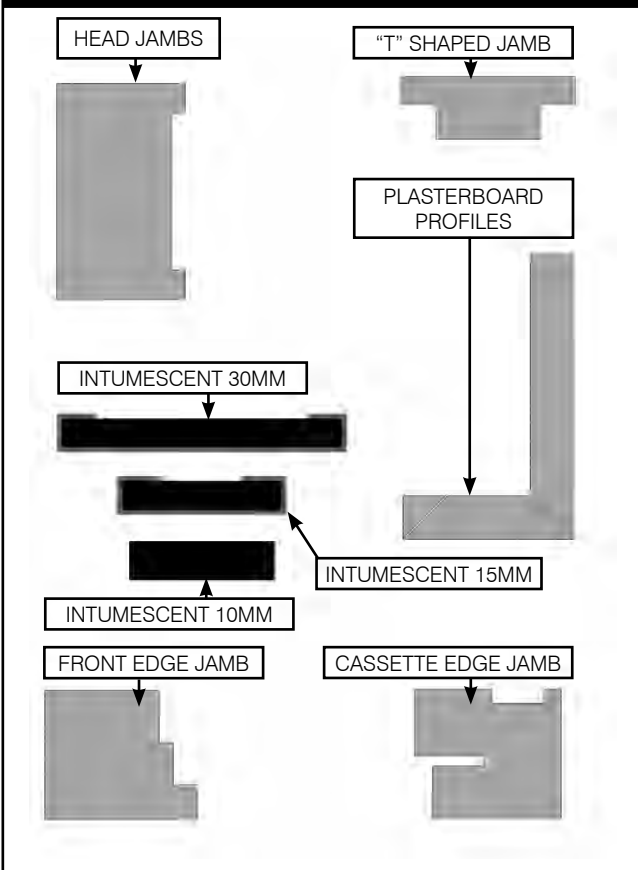

## FIXING ITEMS SET

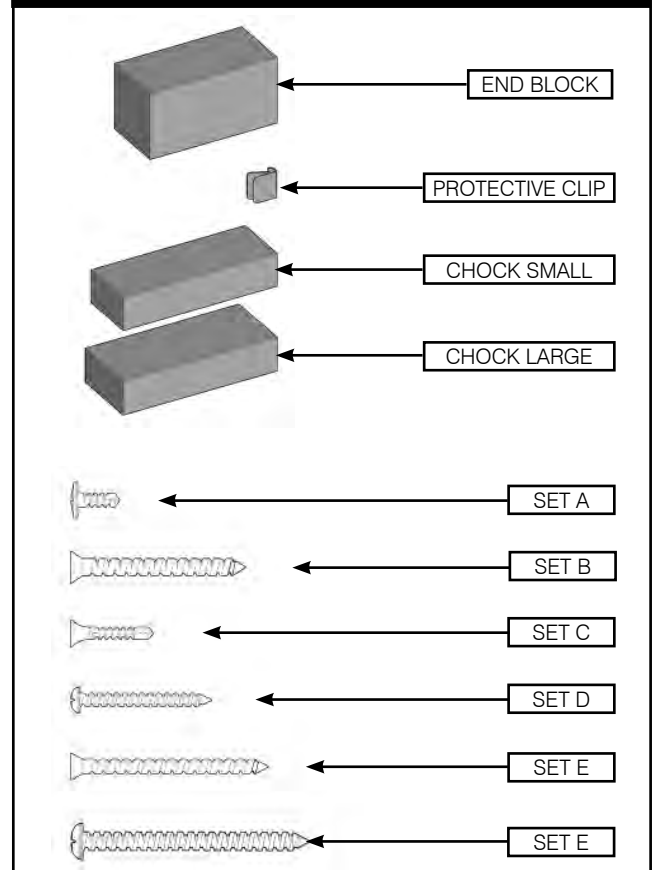

## PRE-DOOR FITTING INFORMATION

Firstly construct a studwork frame on which to affix the pocket door system. Portman doors are designed with 100mm studwork

For correct operation, it is crucial that the frame is constructed square and plumb.

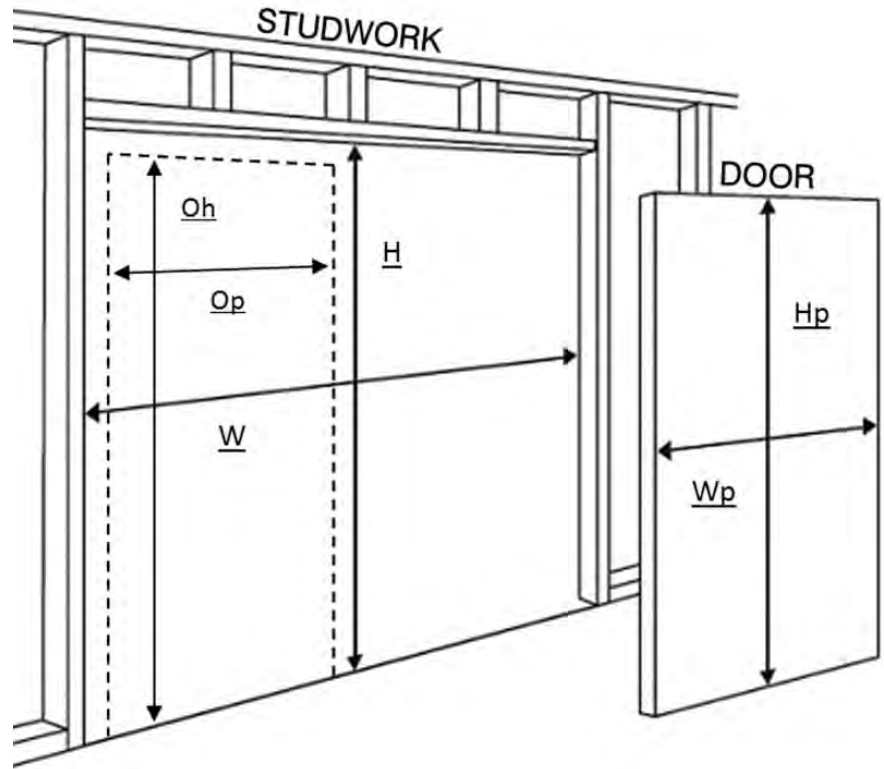

### Abbreviations

W = STUDWORK WIDTH

H = STUDWORK HEIGHT

Op = DOOR OPENING WIDTH

Oh = DOOR OPENING HEIGHT

Wp = DOOR WIDTH

Hp = DOOR HEIGHT

### SIZES CAN BE CALCULATED AS FOLLOWS

**(FOR SINGLE STANDARD DOOR WITH A DOOR THICKNESS OF 44mm)**

1. To calculate **studwork** width and height from known **door dimensions**:

$$\text{Studwork width (W)} = 2 \times \text{Door width (Wp)} - 20\text{mm}$$

$$\text{Studwork height (H)} = \text{Door height (Hp)} + 95\text{mm}$$

2. To calculate **door size** from known **studwork dimensions**:

$$\text{Door width (Wp)} = (\text{Studwork width (W)} + 20\text{mm}) / 2$$

$$\text{Door height (Hp)} = \text{Studwork height (H)} - 95\text{mm}$$

3. To calculate **door size** from known door **opening dimensions**:

$$\text{Door width (Wp)} = \text{Door opening width (Op)} + 95\text{mm}$$

$$\text{Door height (Hp)} = \text{Door opening height (Oh)} + 35\text{mm}$$

4. To calculate **door opening** width and height from known **door dimensions**:

$$\text{Door opening width (Op)} = \text{Door width (Wp)} - 95\text{mm}$$

$$\text{Door opening height (Oh)} = \text{Door height (Hp)} - 35\text{mm}$$

**PLEASE NOTE:**

**IF FITTING A SELF CLOSER OR DAMPER SYSTEM, THE MINIMUM DOOR WIDTH ACHIEVABLE IS 625MM**

**1. TRACK MOUNT**

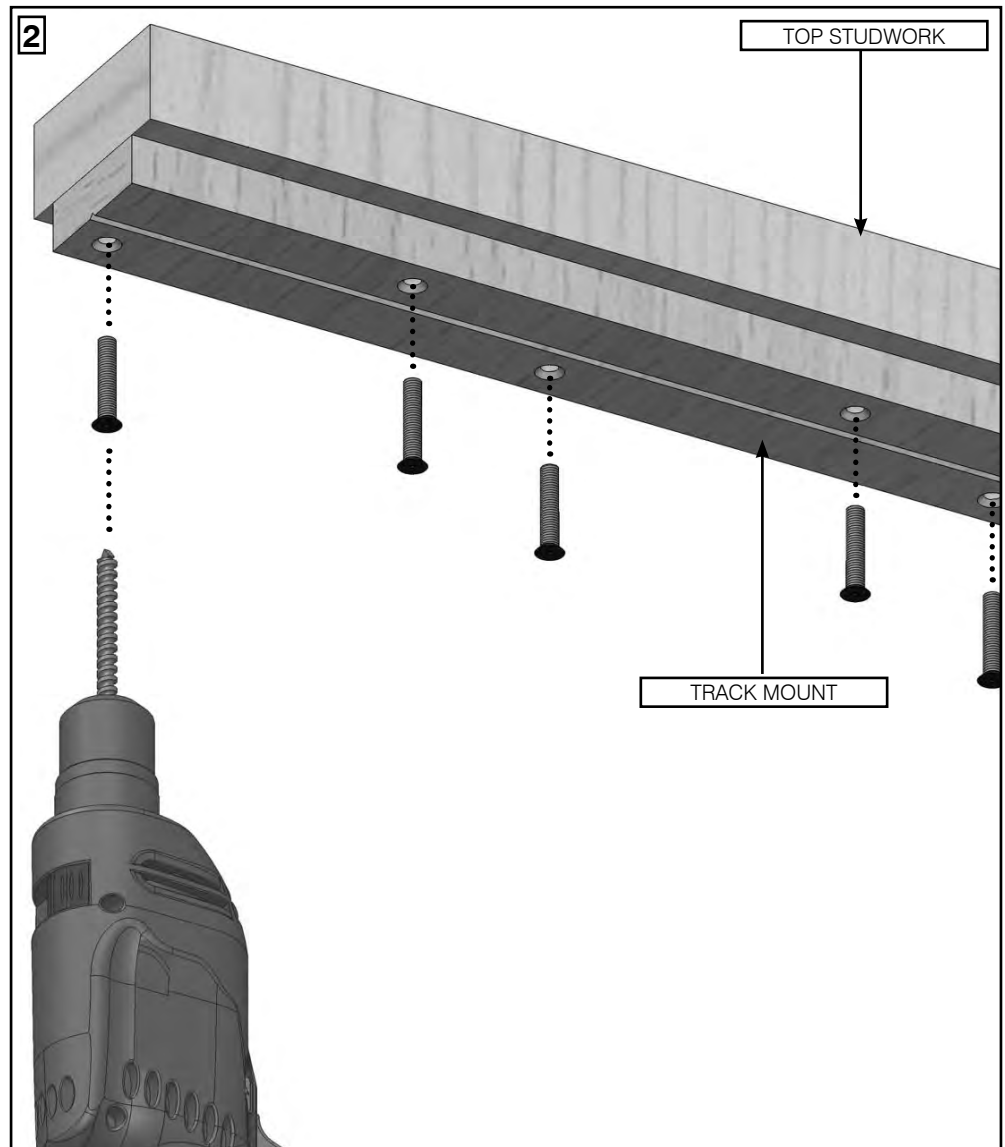
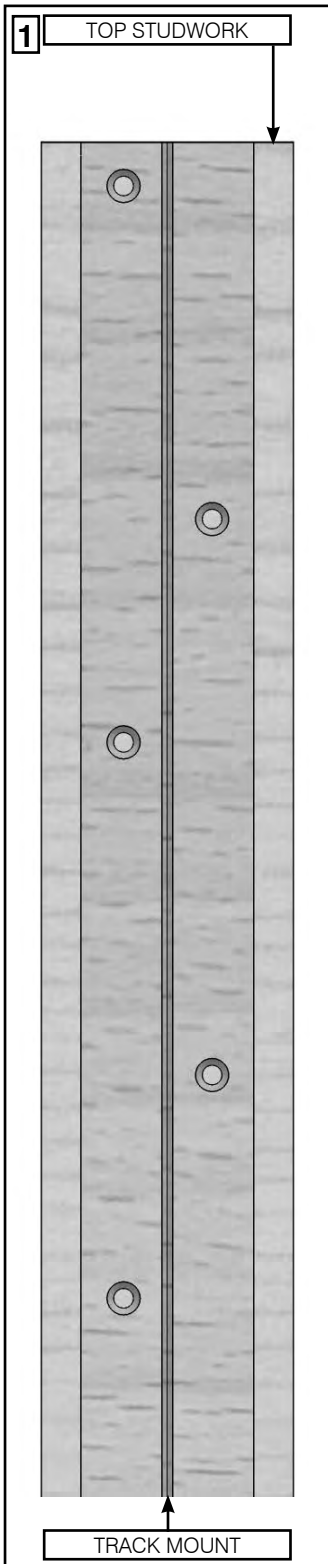

1. Cut the plywood track mount to the width of your horizontal studwork / support frame.
2. Position the track mount in the centre of the top horizontal studwork timber / support frame.
3. Pilot drill and screw through both sides of 'V' Shaped Groove and ensure screw heads are fully sunk into the wood **(Screws not supplied)**.

## 2. ALUMINIUM TRACK

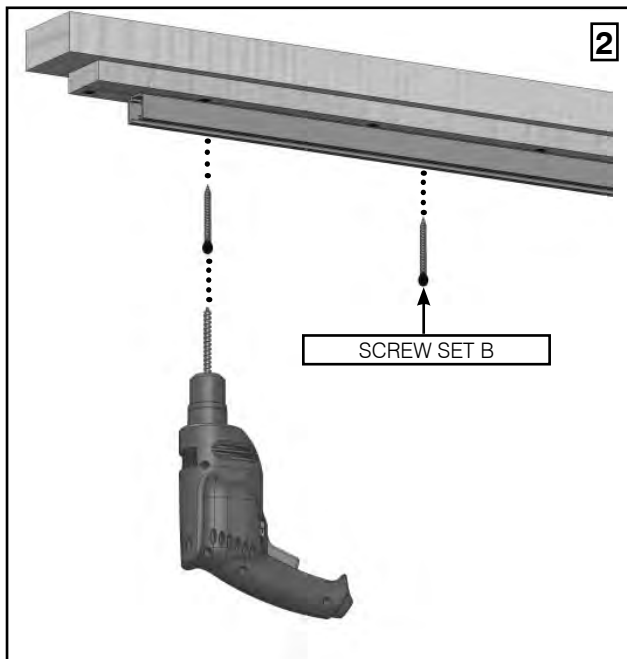
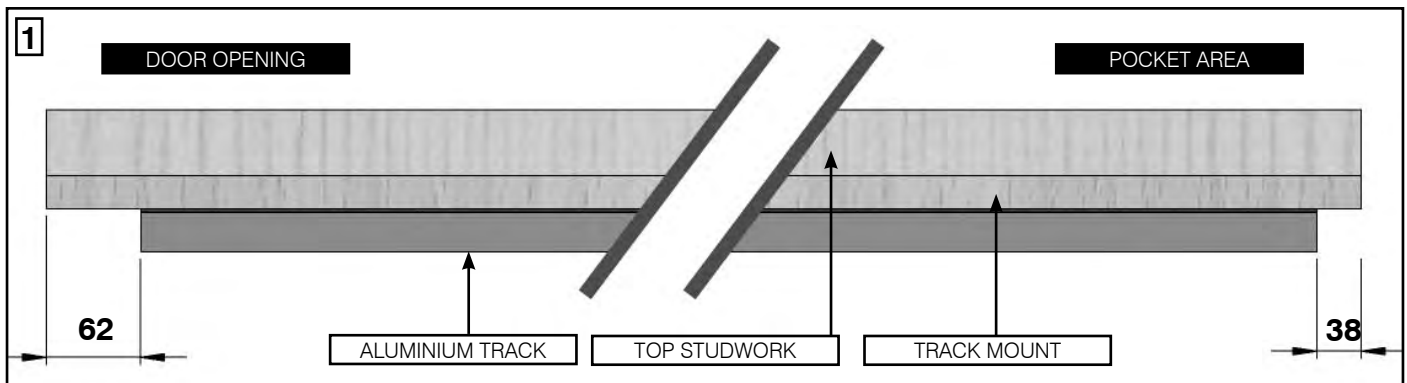

1. Cut the aluminium track to the width of your horizontal studwork, minus 120mm. Position 62mm in from doorway vertical stud to allow for the end block.
2. Pilot drill through the holes in the track into the 'V' Shaped groove in the plywood track mount. Screwfix using **'Screw Set B'**.

**TRACK SHOULD BE WIPED CLEAN TO REMOVE ANY CONTAMINANT**

### 3. SOLE PLATE

1. Position the leading edge of the sole plate (Door panel width minus 9mm) away from the inside face of the rear studwork

**Sole Plate may need cutting down depending on door size.**

2. Butt the sole plate centrally to the studwork at the back edge of the pocket.
3. Plumb true to the aluminium track above and secure the plate to the floor with appropriate fixings (**not supplied**).

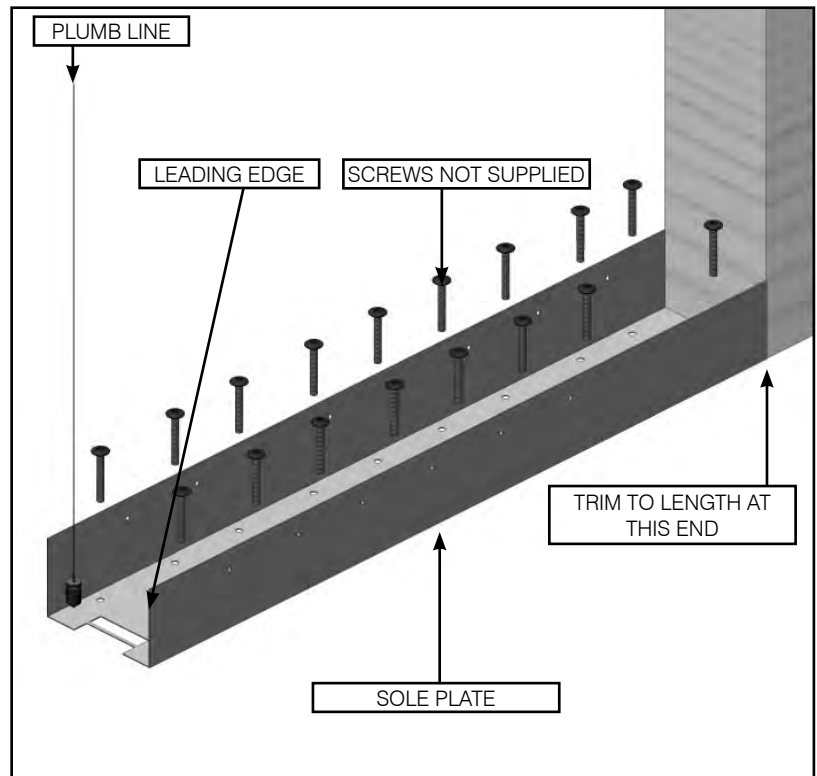

### 4. 'Z' PANELS

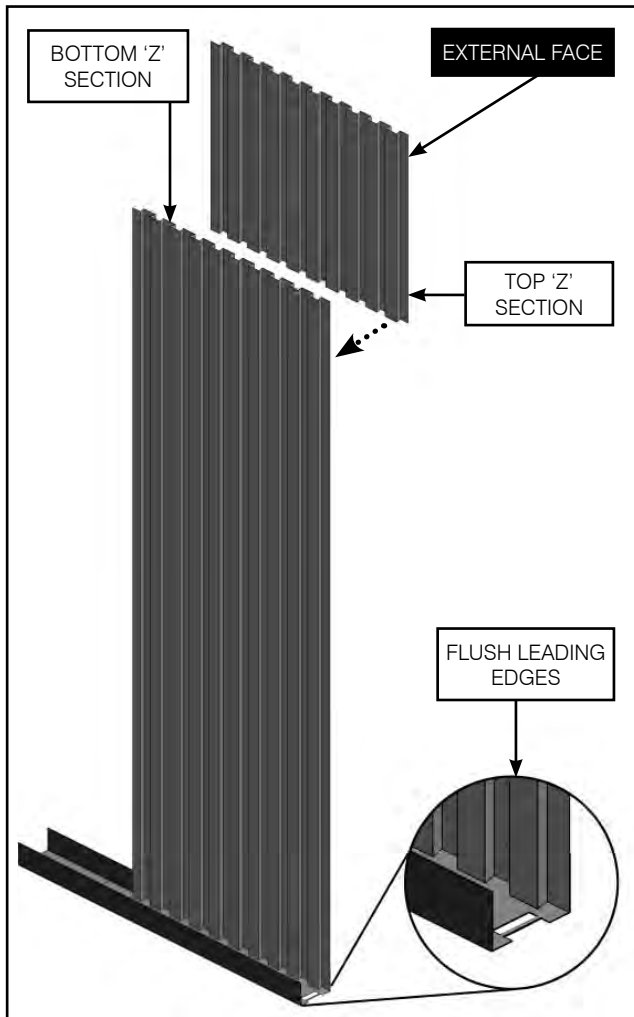

1. Adjust the 'Z' Panels to desired height (inside surface of sole plate to underside of top studwork).
2. Position the bottom 'Z' Panel inside the sole plate so that both leading edges are flush.

**Make sure the top 'Z' section is on the outside of the pocket.**

Please Note: With wide and intermediary kits a second set of metal 'Z' panels are supplied. The second set should be installed level with the rear of the sole plate. On the intermediary kits the narrow sheets should be to the rear of the pocket

**IF YOU ARE USING A REINFORCING KIT - PLEASE REFER TO INSTRUCTIONS 003-285 AND INSTALL IT AT THIS POINT BEFORE SCREW FIXING THE 'Z' PANELS**

**PLEASE NOTE: TOP 'Z' SECTION IS ON THE OUTSIDE OF THE POCKET**

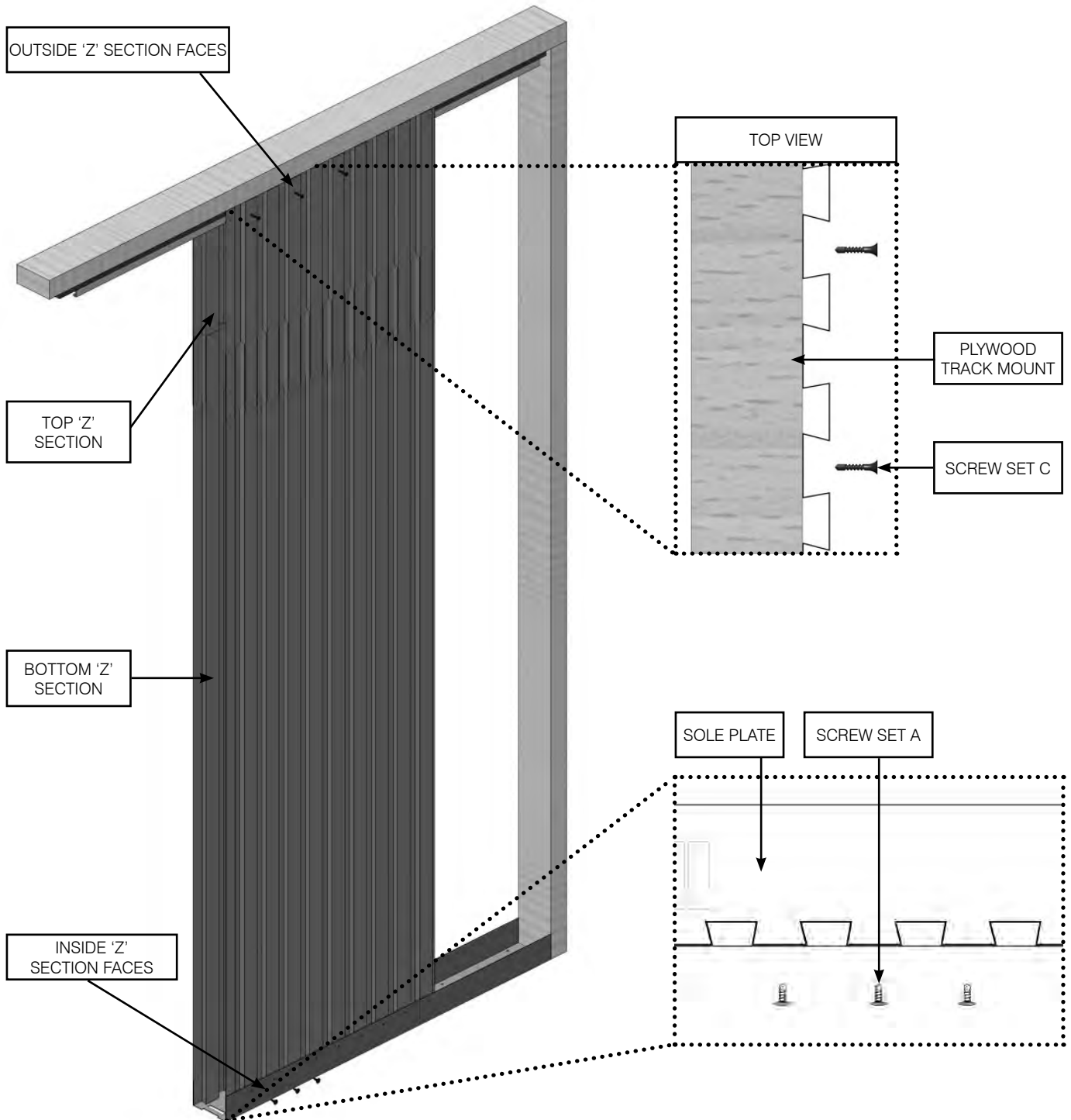

Ensure panels are level and then fix with screws.

1. Fix top 'Z' Section to plywood track mount with **'Screw Set C'**.
2. Fix bottom 'Z' section to sole plate with **'Screw Set A'**.

## 5. PANEL JOINING

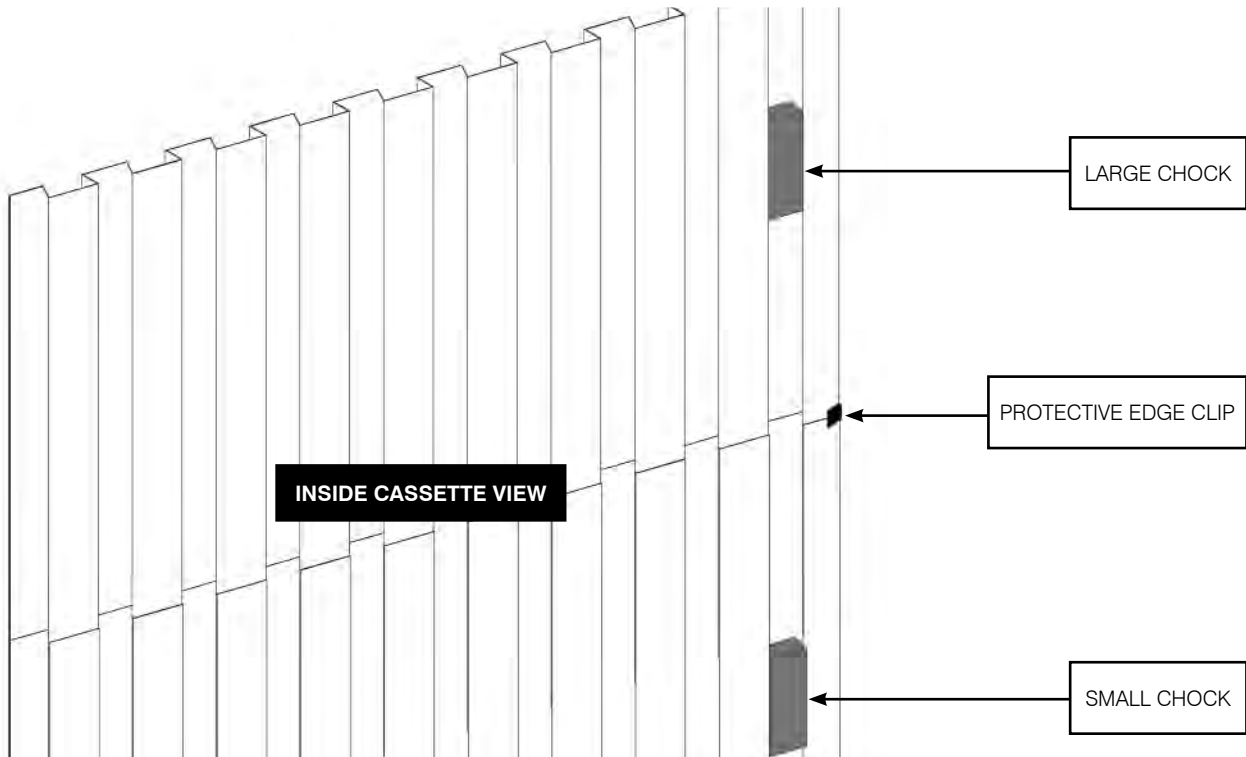

At the back of the pocket, place the protective edge clip onto the 'Z' section, covering where the panels join.

In the last 'Z' section slot towards the back of the inside pocket, push the large chock into the top 'Z' section and the two small chocks into the bottom 'Z' section.

This pushes the edge outwards so the door does not snag on it when closing.

For intermediary and wide kits, fit the chocks in the first and last slot in the rear 'Z' sections as detailed above. Fit protective edge clips to all joints on rear panels.

Repeat stages 4 - 5 on the other side of the pocket.

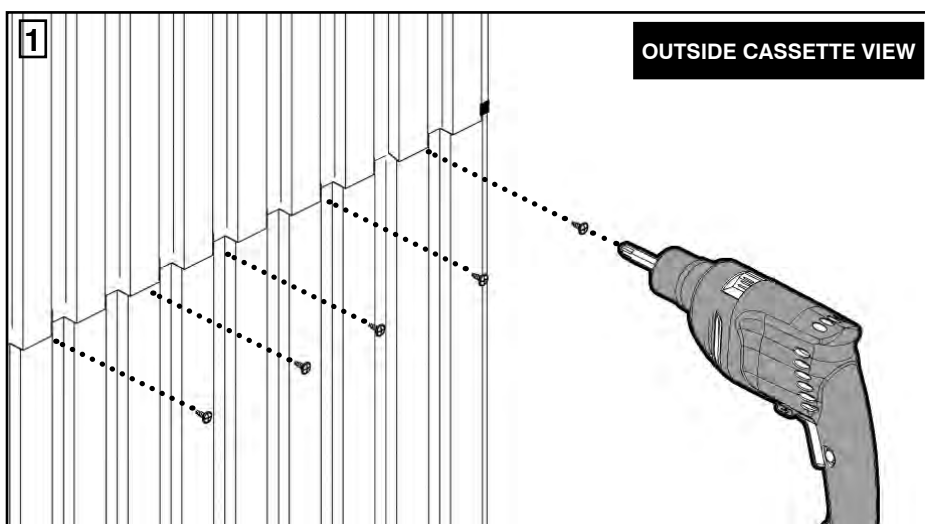

1. Screw through from outside to join panels together in five locations using '**Screw Set A**' (pilot holes not required).

ENSURE WHEN SCREWING THE TWO SHEETS THEY ARE STRAIGHT AND DO NOT BECOME BOWED AS THE SCREW PUSHES THROUGH

## 6. TROLLEY MOUNTING

### PLEASE NOTE:

**IF FITTING A SELF CLOSER OR DAMPER SYSTEM ON A DOOR BELOW 700MM WIDTH, ADJUST BRACKET CENTRES TO 120MM AWAY FROM THE DOOR EDGE**

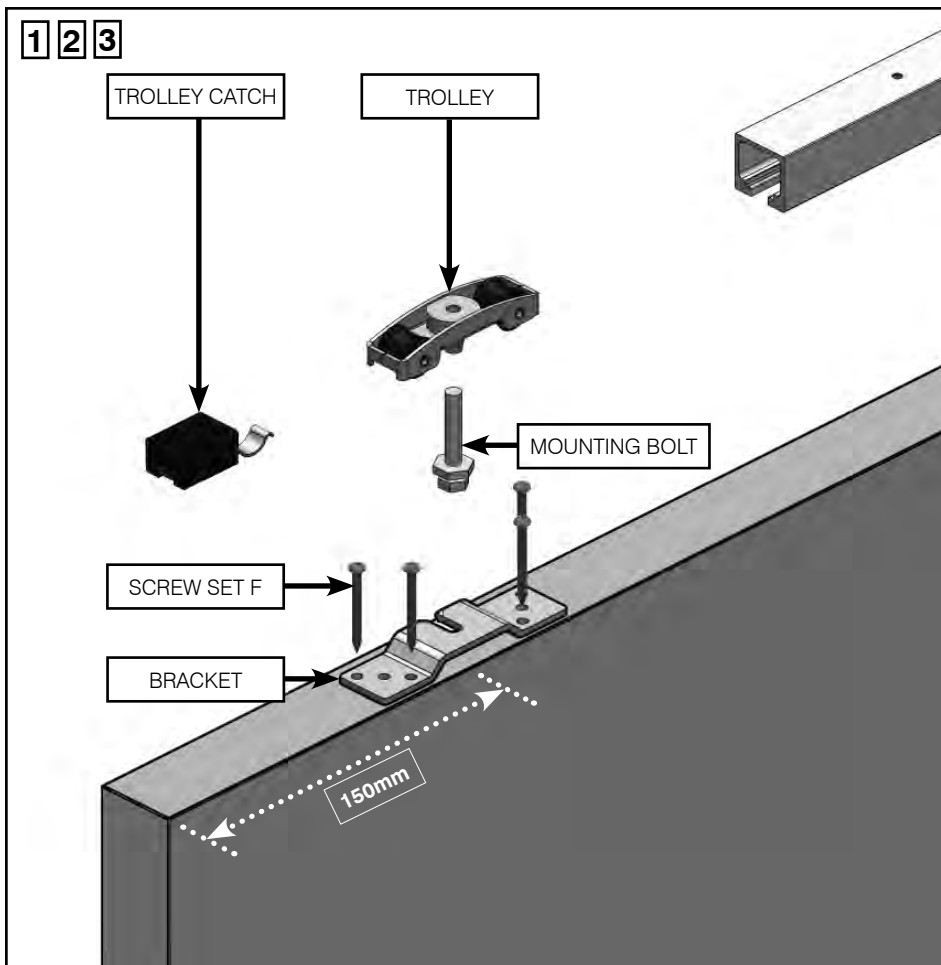

1. Fit the bracket centrally to the top edge of the door using '**Screw Set F**'. Ensure the bracket centre is 150mm away from the door edge. Repeat the procedure for the other bracket.
2. Screw the mounting bolts into the trollies. Ensure both bolts are screwed in the same amount on both trollies to ensure the door is level and make adjustment easier.
3. Slide both assembled trollies into the top rail.
4. Slide both trolley catches into the track, one at the front and one at the back. Do not fix them in place until the door has been hung (This is explained in Stage 10 of the instructions)

## 7. DOOR GUIDE

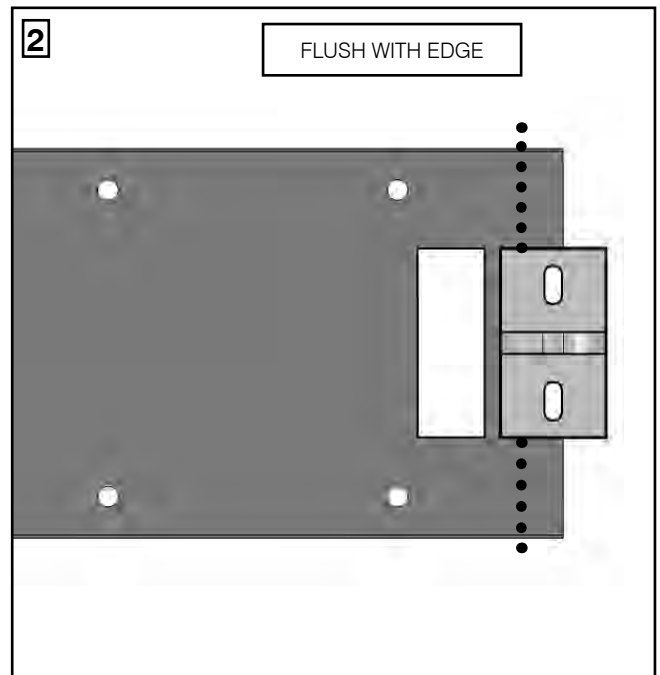
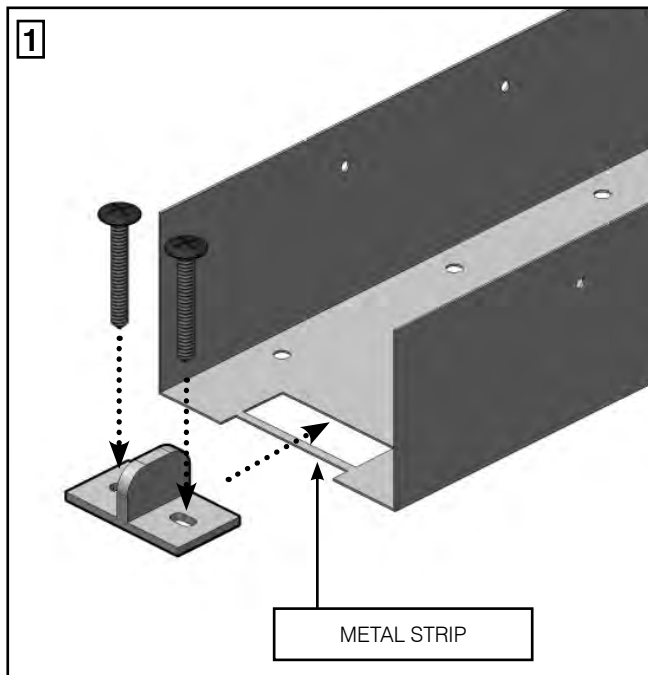

1. Fix the metal floor guide into the sole plate by inserting it into the pre-cut area.
2. Ensure it is flush against the metal strip and then scew fix firmly into the floor (**screws not included**).

## 8. BOTTOM DOOR GROOVE

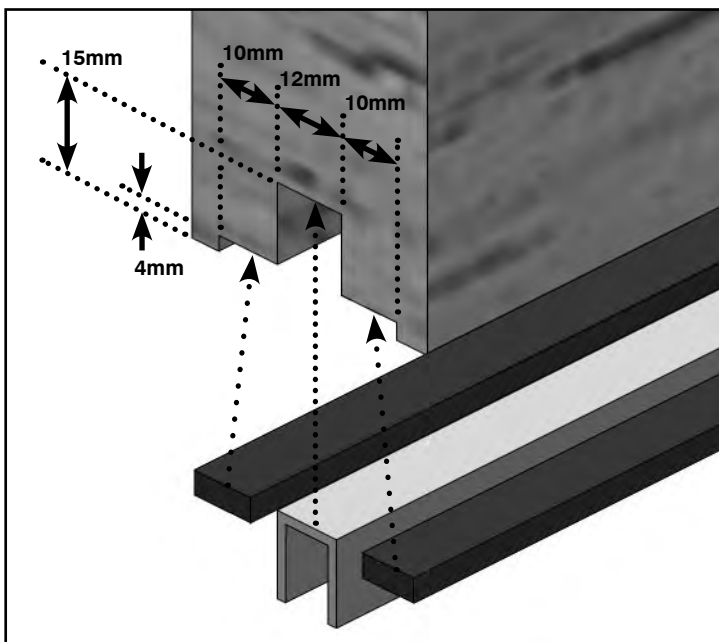

1. Cut a groove in the bottom face of the door to suit the plastic channel which the floor guide runs in and the two 10x4mm intumescent strips.

Ensure when cutting the groove it is centralised along the width of the door with equal measurements either side.

2. Bond the channel into the cut groove using a polyurethane glue or pin, ensuring the metal floor guide can move freely within it.

Stick the intumescents using their self adhesive backing tape.

## 9. DOOR HANGING

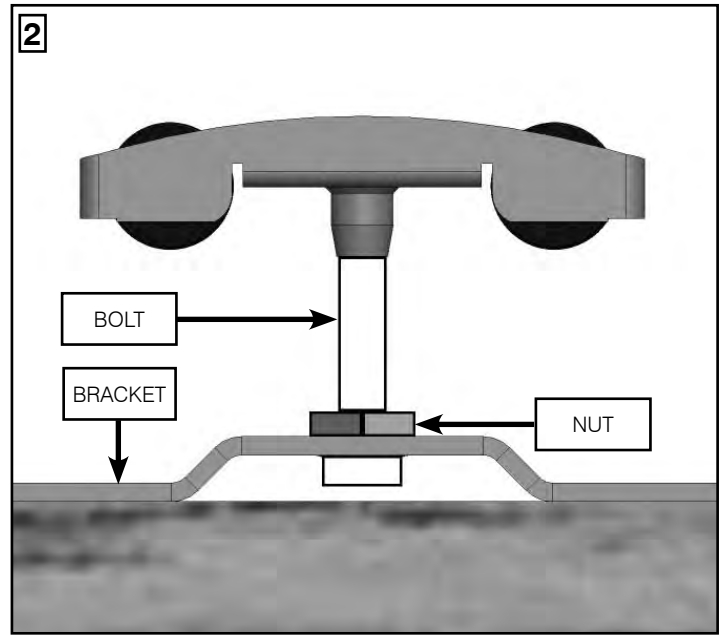
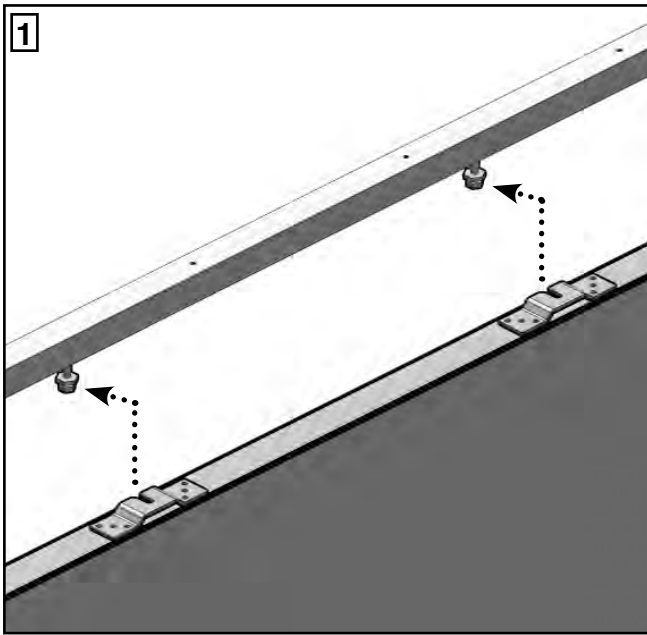

1. Hang the door by sliding the brackets onto the bolts, taking care not to damage the door on the floor guide.
2. Tighten the top nuts onto the brackets to fix the trolleys into place.

**TEST TO SEE IF THE DOOR RUNS SMOOTHLY AND IS PLUMB**

**IF NOT, CORRECT BY ADJUSTING THE NUTS AND BOLTS**

## 10. TROLLEY CATCHES

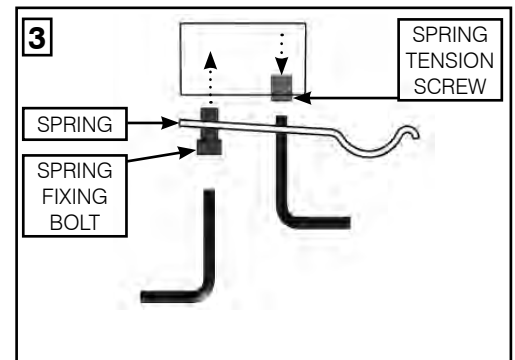
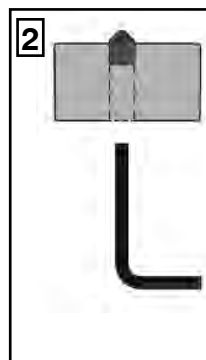
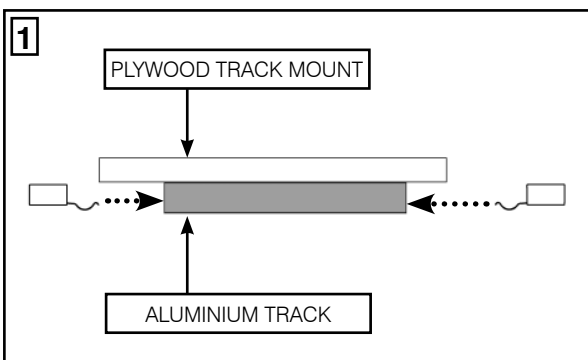

1. Place trolley catches in front and back of aluminium track.
2. Fix trolley catches in required positions within the aluminium track by removing the spring giving access to the centre hole locking grub screw. A 3mm allen key is required.
3. Replace the spring and adjust the clamping bolt to the desired tension to hold the trolleys in place using an M5 allen key.

## 11. JAMB FITTING - CASSETTE JAMBS

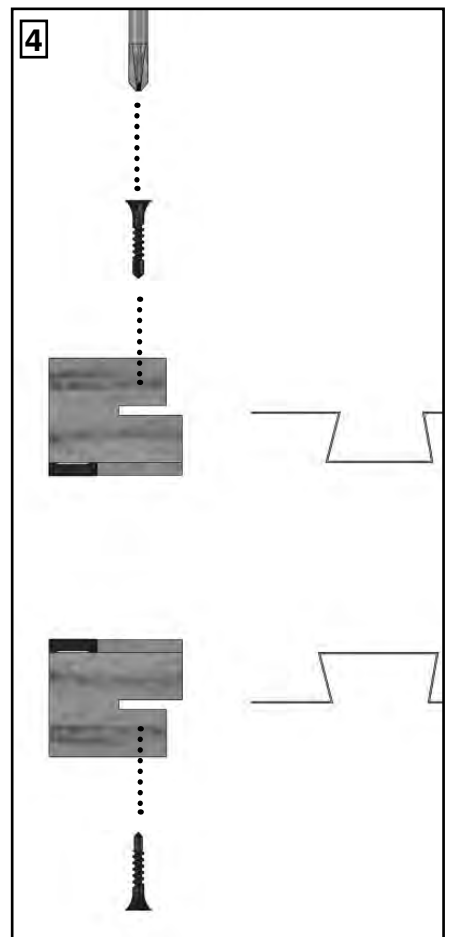
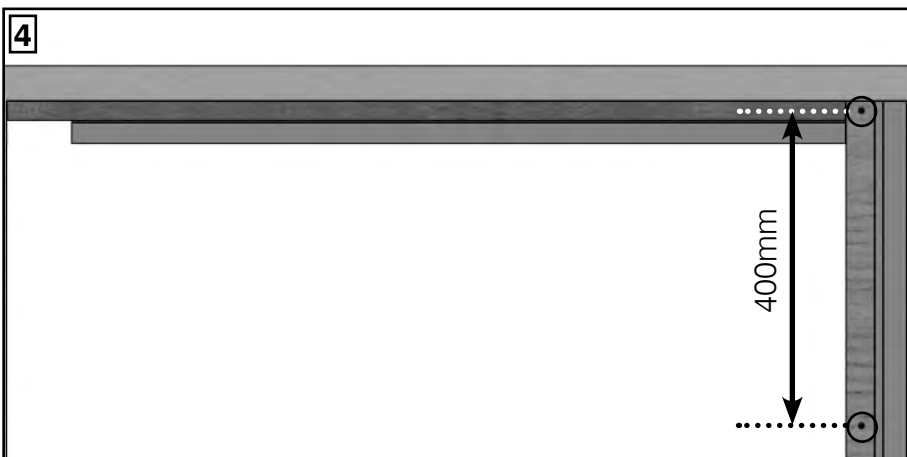
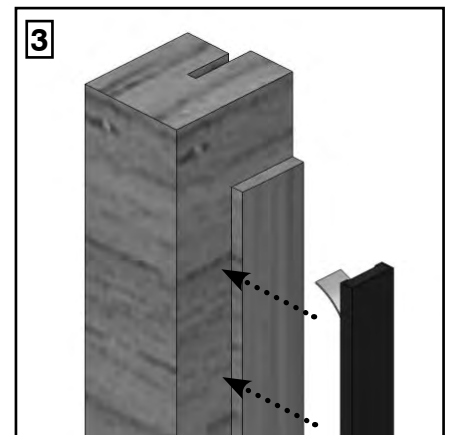
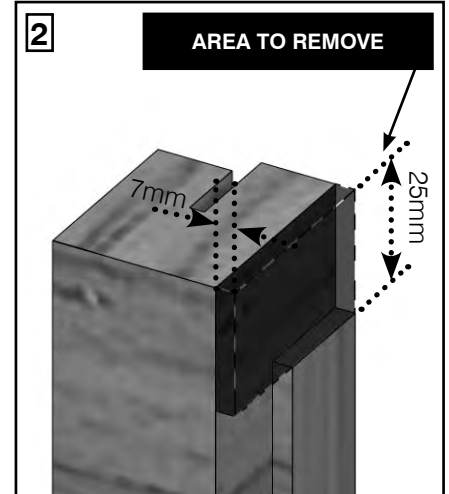
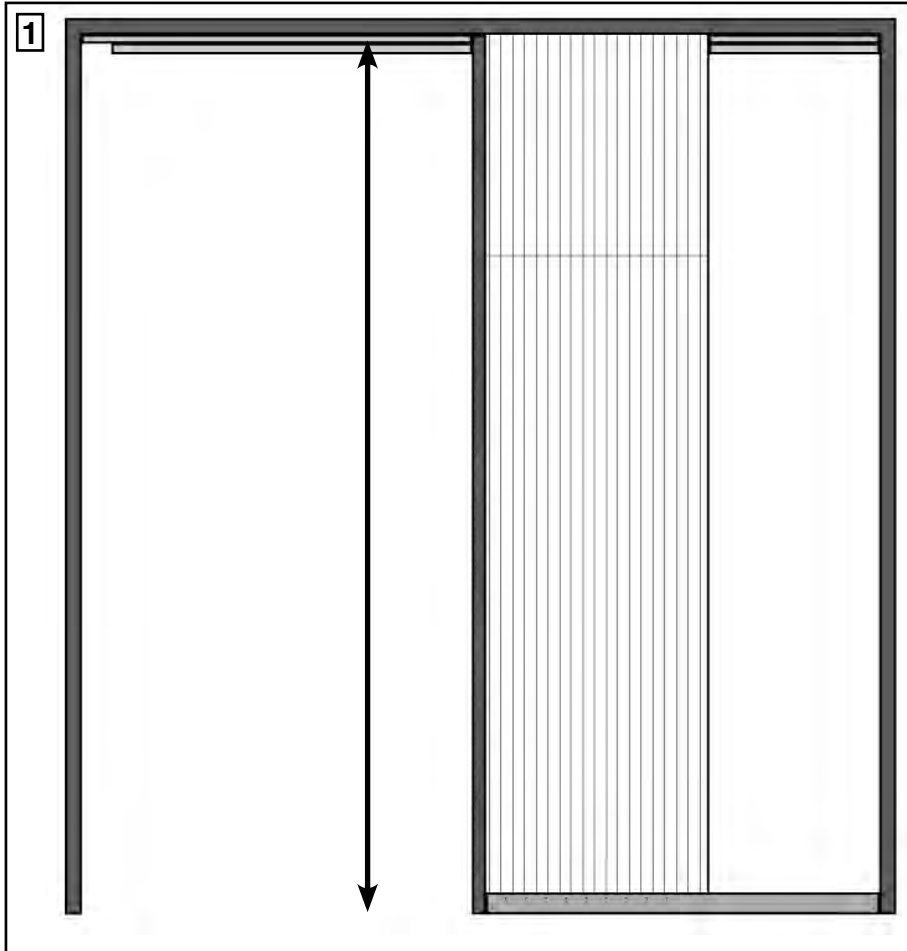

1. Cut the cassette jambs to the aperture height from floor to underside of stud.
2. Using a cutting or sawing tool cut a notch at the top of both jambs that is 25mm down and 7mm deep.
3. Install 15mm x 4mm intumescent strips using their self adhesive backing into the preformed slots in the jambs.
4. Press the jambs onto the edge of the 'Z' Sections and secure with 'Screw Set C'. Screw at the top and bottom and then approximately every 400mm.

## 12. 'L' SHAPED TRACK PACKERS

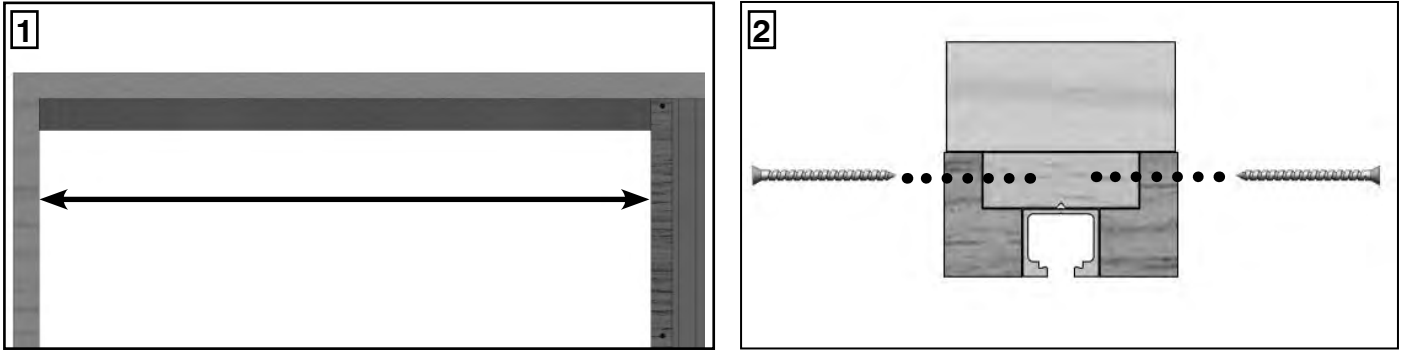

1. To cut the 'L' Shaped track packers, measure remaining door opening width.
2. To secure the 'L' shaped packers, first pilot and countersink a series of holes in their length every 300mm. Screw surely through into the plywood track mount using '**Screw Set E**'.

## 13. JAMB FITTING - FRONT EDGE JAMBS

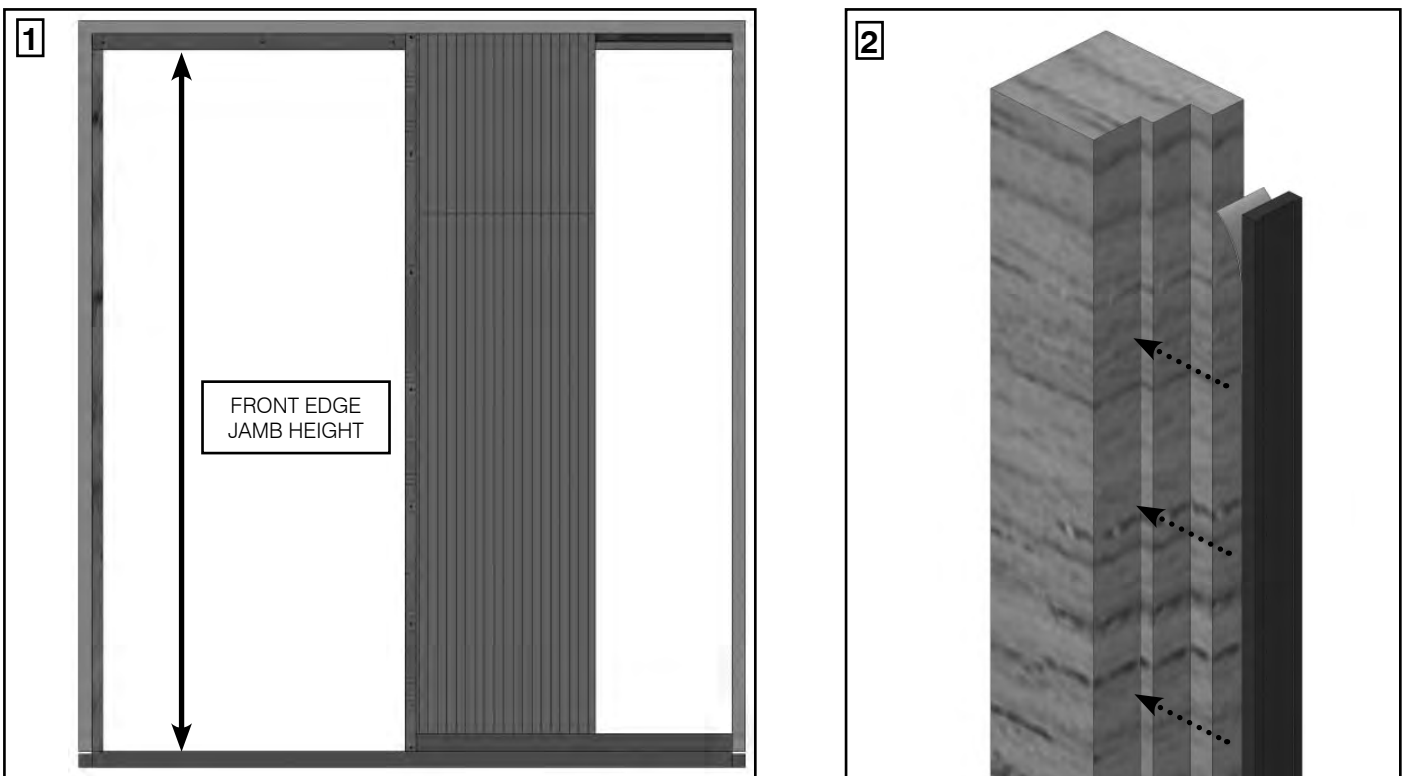

1. Using a sawing or cutting tool, cut the front edge jamb lengths and the 'T' shaped jamb to fit from the the floor to the underside of the 'L' Shaped Track Packers.
2. Install the 15mm x 4mm Intumescent strips using their self adhesive backing on the front edge jambs.

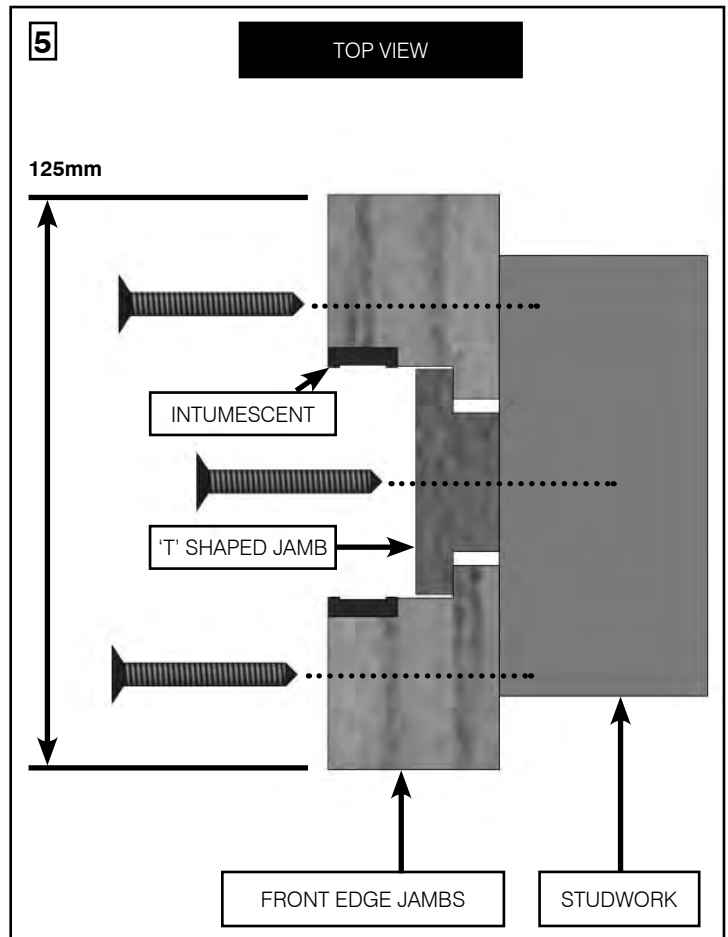
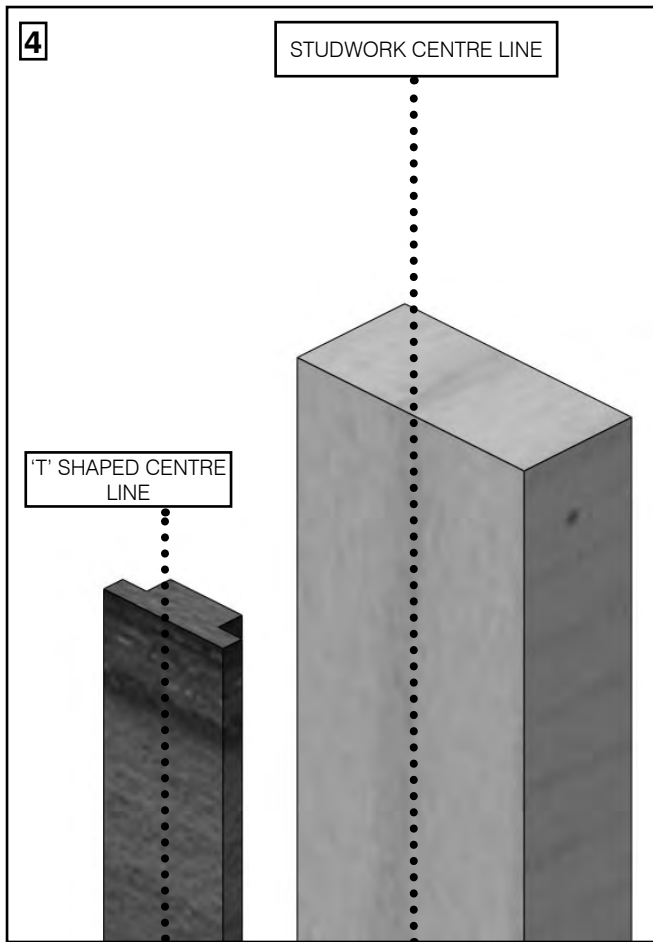

4. The 'T' shaped jamb must be fitted at the centre of your studwork. Carefully measure the stud and 'T' jamb, marking their vertical centre lines with a pencil. Line up the two centre lines prior to screw fixing.
5. Screw fix the 'T' Shaped Jamb first into its central position. Screws not supplied but we strongly suggest using 62mm long 4mm diameter steel screws spaced every 300mm along the Jamb length.

Place the front edge jambs against the studwork, slotting either side of the 'T' Shaped Jamb and screw fix using the same screws and spacing.

## 14. JAMB FITTING - HEAD JAMB

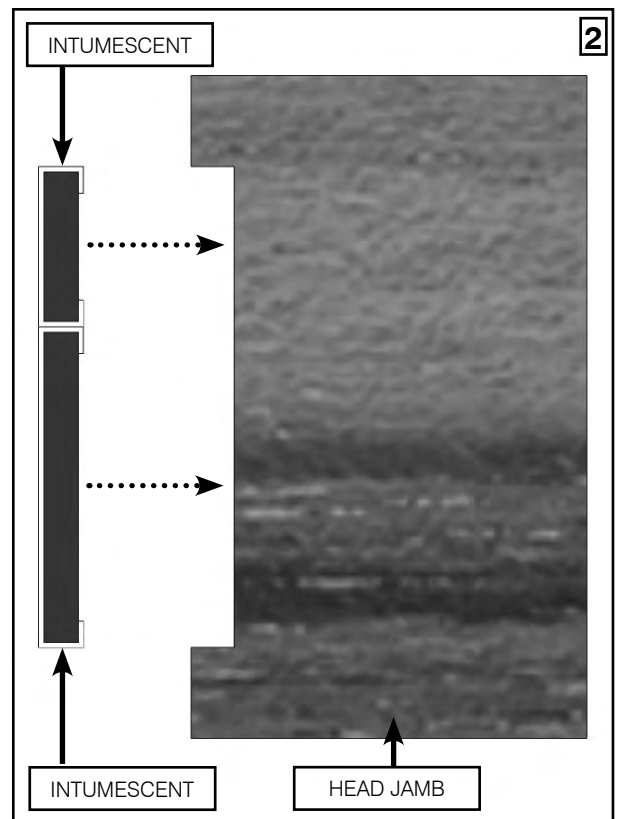
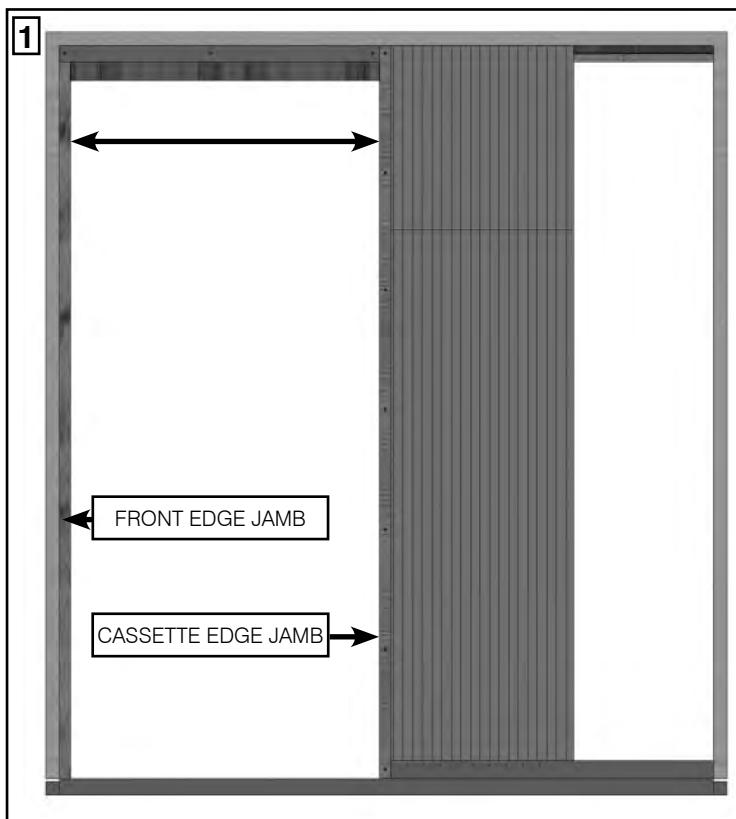

1. Cut the head jambs to fit between the front edge jamb and the cassette edge jamb.
2. Install 30mm x 4mm and 15mm x 4mm intumescent strips using their self adhesive backing into the preformed slots in the head jambs.
3. The head jambs can be secured to the L-Shaped Track packers using 80mm woodscrews to screw through the head section fixing into the L-Shaped Track Packer. Position screws at 300mm intervals

**Screws are not supplied**

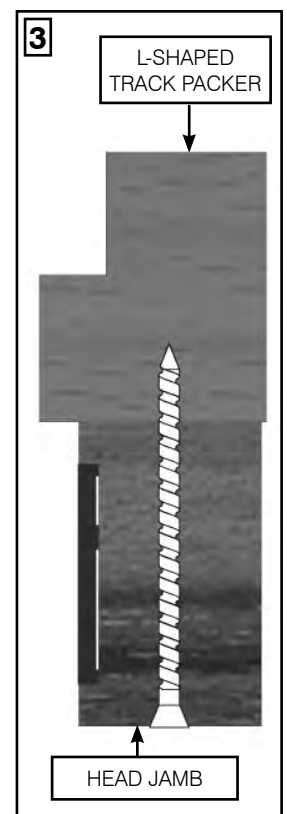

## 15. DELTA SMOKE SEALS

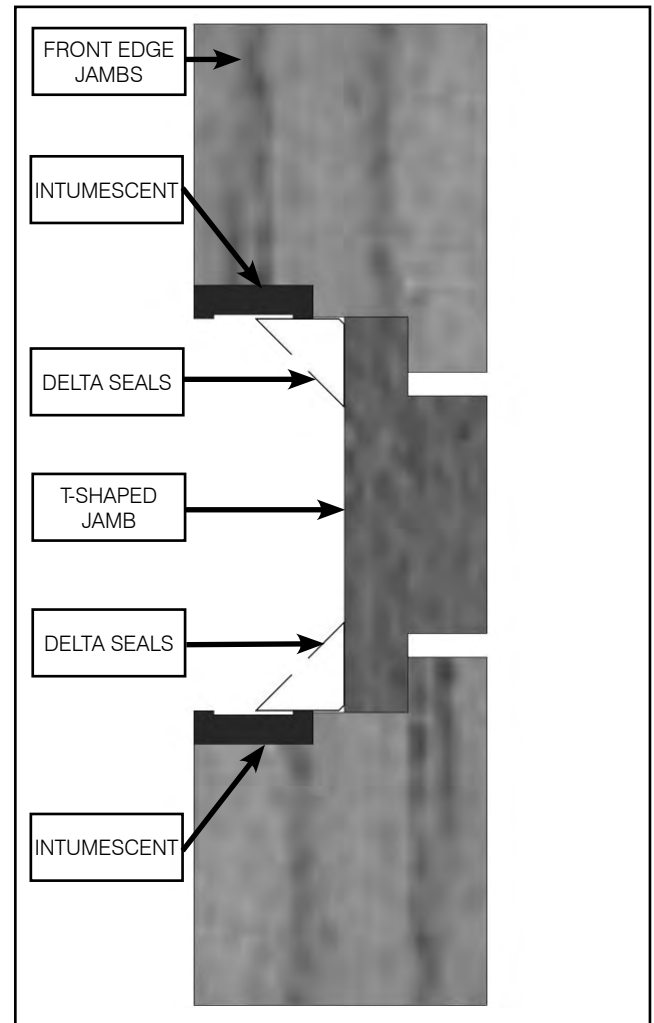
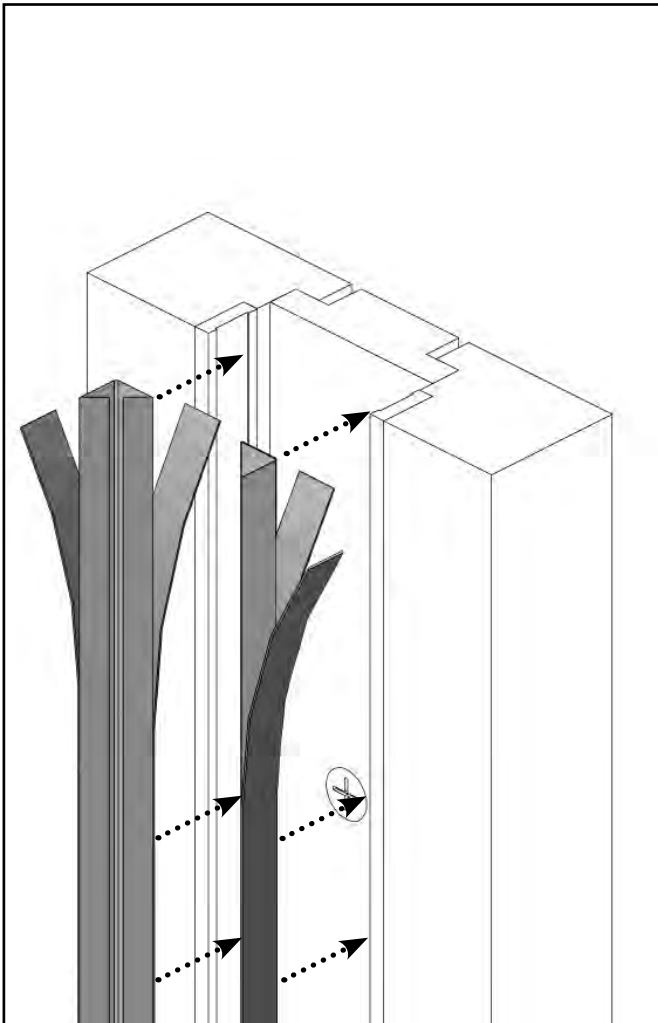

1. Cut the delta seals to fit the length between the 'L' Shaped track packers and the floor.  
Remove adhesive covers and secure to where the 'T' shaped jamb meets the front edge jamb

## 16. END BLOCK

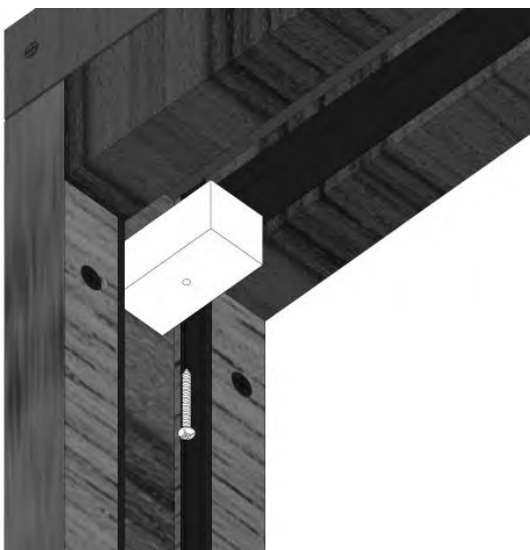

1. Pilot drill a hole in the wooden end block using a 2.1mm drill bit. Drill the hole in the centre of the block.
2. Using the newly made hole, with '**Screw Set D**', screw into the 82mm spacing left between the aluminium track and the studwork. Make sure the end block is butted against the track.

## 17. PLASTERBOARD

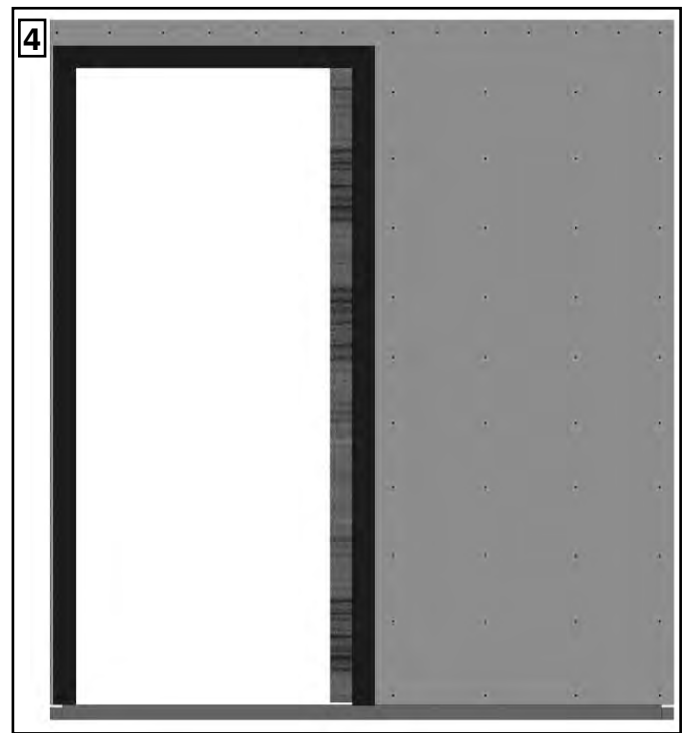
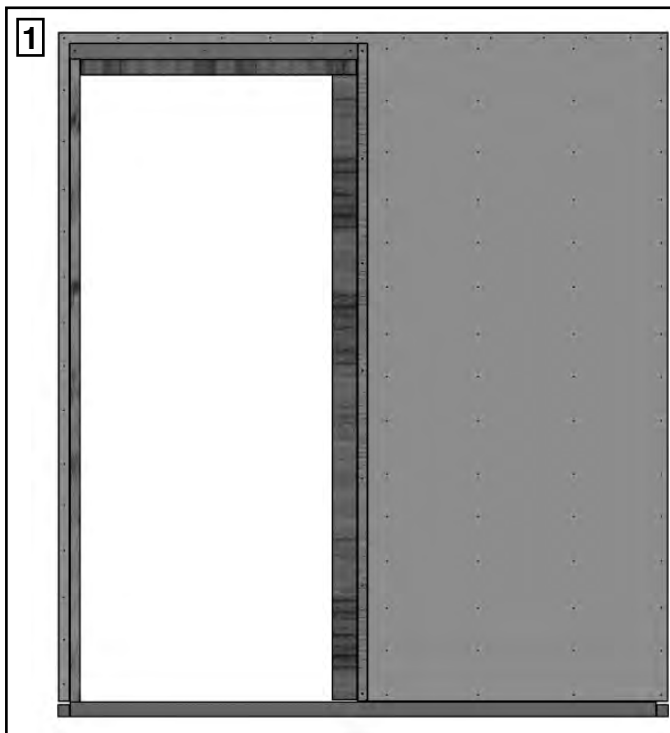

1. Clad the kit in the first layer of 12.5mm thick fire rated plasterboard. Ensure it butts up tight against the outside of all jambs.
2. Cut the top piece profile to the width from inside edge of front edge jamb to inside edge of cassette jamb. Add on to this 140mm for overlaps.
3. Cut 70mm off each end as shown.
4. Cut to size and install vertical sections which fit from the floor to the underside of the top piece you have just installed.
5. Clad the kit in a final layer of fire rated plasterboard, butting the sheets up to the pre-formed sections.

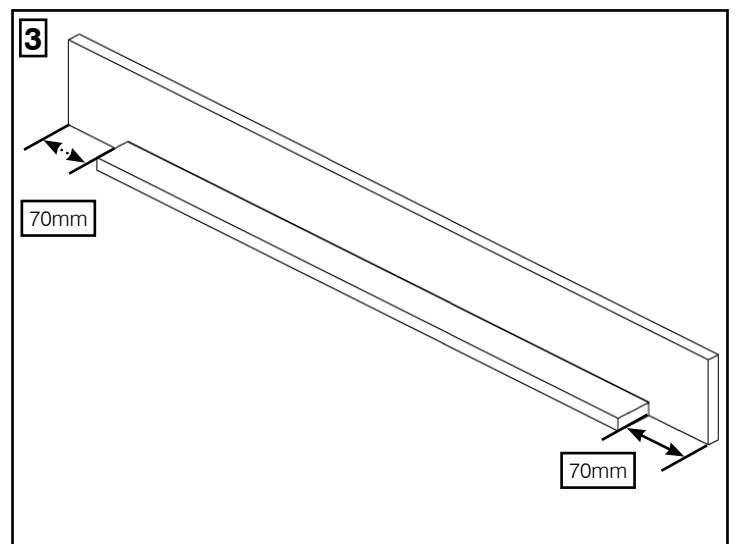

**Take care that any screws do not protrude into the pocket cavity  
FIXINGS FOR THIS STAGE ARE NOT SUPPLIED**