

PORTMAN

P7300 Timber Door

Architrave Free Kit

FITTING INSTRUCTIONS



(Image for reference only)

SUGGESTED TOOLS



DRILL



G-CLAMP



TAPE MEASURE



HACKSAW



PLUMB LINE



HANDSAW



SPIRIT LEVEL



PROTECTIVE EQUIPMENT

COMPONENTS

POCKER DOOR KIT

- SHORT / LONG 'Z' SECTION
- LONG 'Z' SECTION
- L-SHAPED TRACK PACKER
- PLYWOOD TRACK MOUNT
- ALUMINIUM TRACK
- DOOR BOTTOM CHANNEL
- SOLE PLATE
- DOOR SEAL

*
*
*
*
*
*
*
*

DOOR JAMB SET

- HEAD SECTION
- FRONT EDGE JAMB
- CASSETTE EDGE JAMB

2
1
2

SLIDING MECHANISM

- TROLLEY CATCH
- TROLLEY ASSEMBLY
- BRACKET
- FLOOR GUIDE

2
2
2
1

FIXING ITEMS

- END BLOCK
- PROTECTIVE EDGE CLIP
- CHOCK LARGE
- CHOCK SMALL
- SET A
- SET B
- SET C
- SET D
- SET E

1
*
*
*
*
*
*

* Quantities are dependant on type of kit ordered

POCKET DOOR KIT

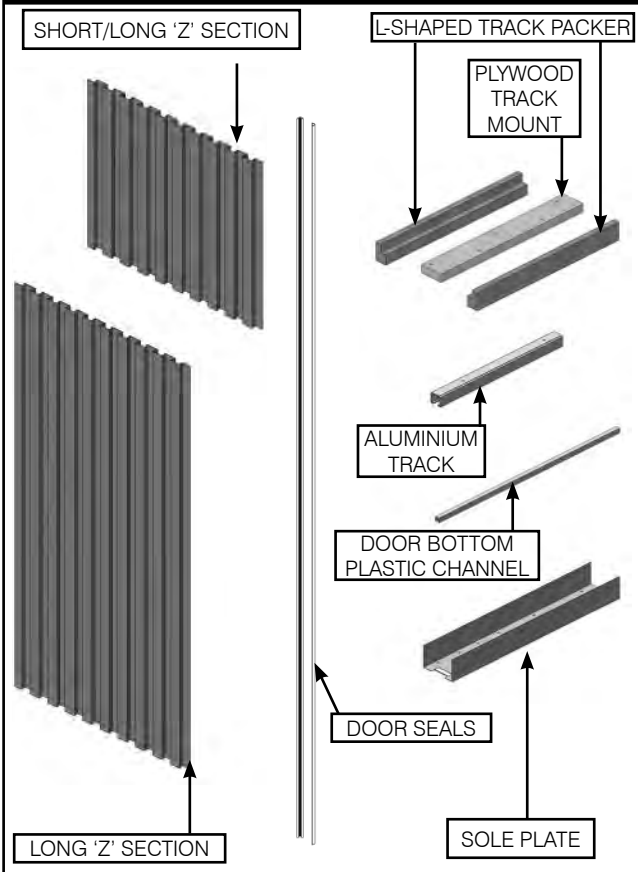

SLIDING MECHANISM

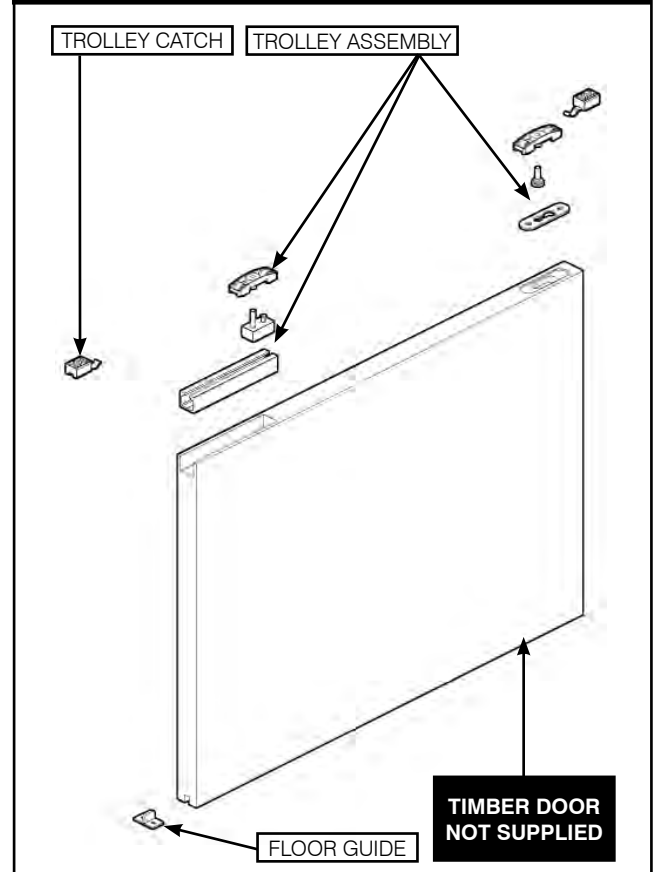

DOOR JAMB SET

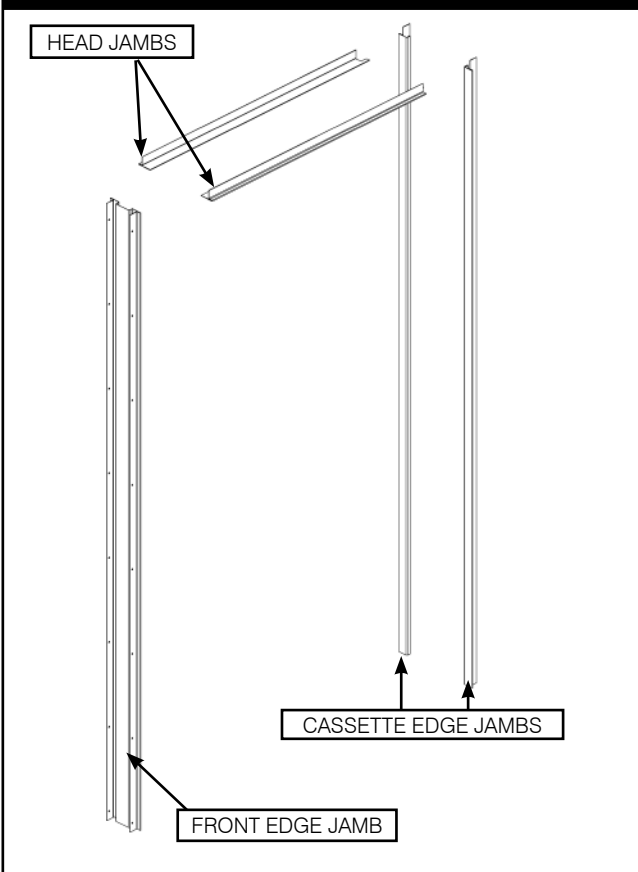

FIXING ITEMS SET

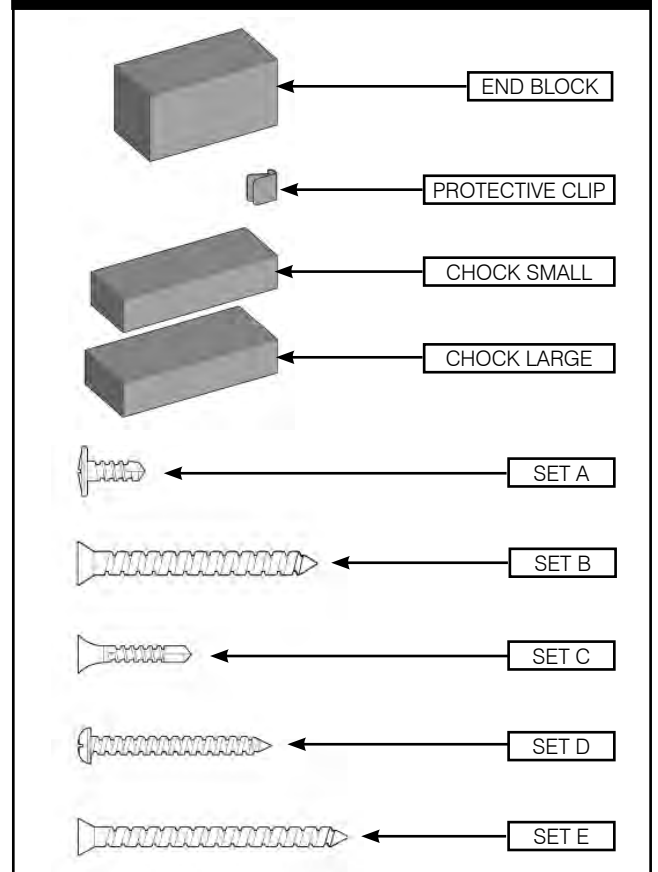

PRE-DOOR FITTING INFORMATION

Firstly construct a studwork frame on which to affix the pocket door system. Portman doors are designed with 100mm studwork

For correct operation, it is crucial that the frame is constructed square and plumb.

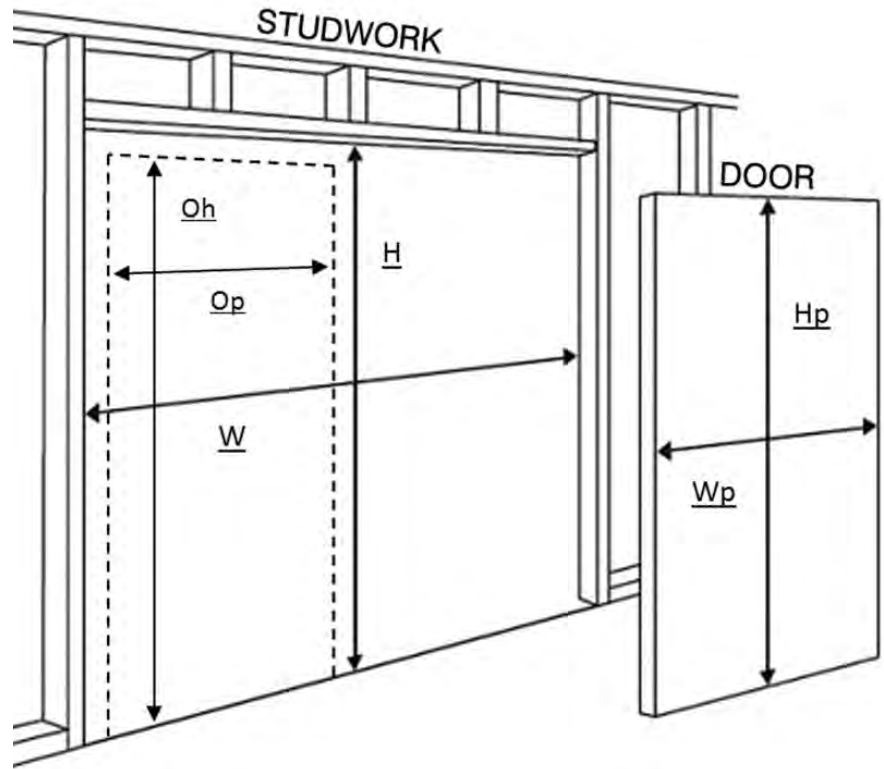

Abbreviations

W = STUDWORK WIDTH

H = STUDWORK HEIGHT

Op = DOOR OPENING WIDTH

Oh = DOOR OPENING HEIGHT

Wp = DOOR WIDTH

Hp = DOOR HEIGHT

SIZES CAN BE CALCULATED AS FOLLOWS

(FOR SINGLE FLUSH DOOR WITH A MAX DOOR THICKNESS OF 44mm)

- To calculate **studwork** width and height from known **door dimensions**:

$$\text{Studwork width (W)} = 2 \times \text{Door width (Wp)} + 12\text{mm}$$

$$\text{Studwork height (H)} = \text{Door height (Hp)} + 70\text{mm}$$

$$\text{For double doors: (W)} = 4 \times \text{(Wp)} + 18\text{mm}$$

$$\text{For double doors: (H)} = \text{(Hp)} + 70\text{mm}$$

- To calculate **door size** from known **studwork dimensions**:

$$\text{Door width (Wp)} = (\text{Studwork width (W)} - 12\text{mm}) / 2$$

$$\text{Door height (Hp)} = \text{Studwork height (H)} - 70\text{mm}$$

$$\text{For double doors: (Wp)} = ((\text{W}) - 18\text{mm}) / 4$$

$$\text{For double doors: (Hp)} = \text{(H)} - 70\text{mm}$$

- To calculate **door size** from known door **opening dimensions**:

$$\text{Door width (Wp)} = \text{Door opening width (Op)} + 28\text{mm}$$

$$\text{Door height (Hp)} = \text{Door opening height (Oh)} - 14\text{mm}$$

$$\text{For double doors: (Wp)} = ((\text{Op}) + 32\text{mm}) / 2$$

$$\text{For double doors: (Hp)} = \text{(Oh)} - 14\text{mm}$$

- To calculate **door opening** width and height from known **door dimensions**:

$$\text{Door opening width (Op)} = \text{Door width (Wp)} - 28\text{mm}$$

$$\text{Door opening height (Oh)} = \text{Door height (Hp)} + 14\text{mm}$$

$$\text{For double doors: (Op)} = (2 \times \text{(Wp)} - 32\text{mm})$$

$$\text{For double doors: (Oh)} = \text{(Hp)} + 14\text{mm}$$

PLEASE NOTE:

**FOR DOUBLE DOOR INSTALLATION, MIRROR STEPS 3-7, 9, 11
THIS ALLOWS FOR THE OTHER POCKET.**

1. TRACK MOUNT

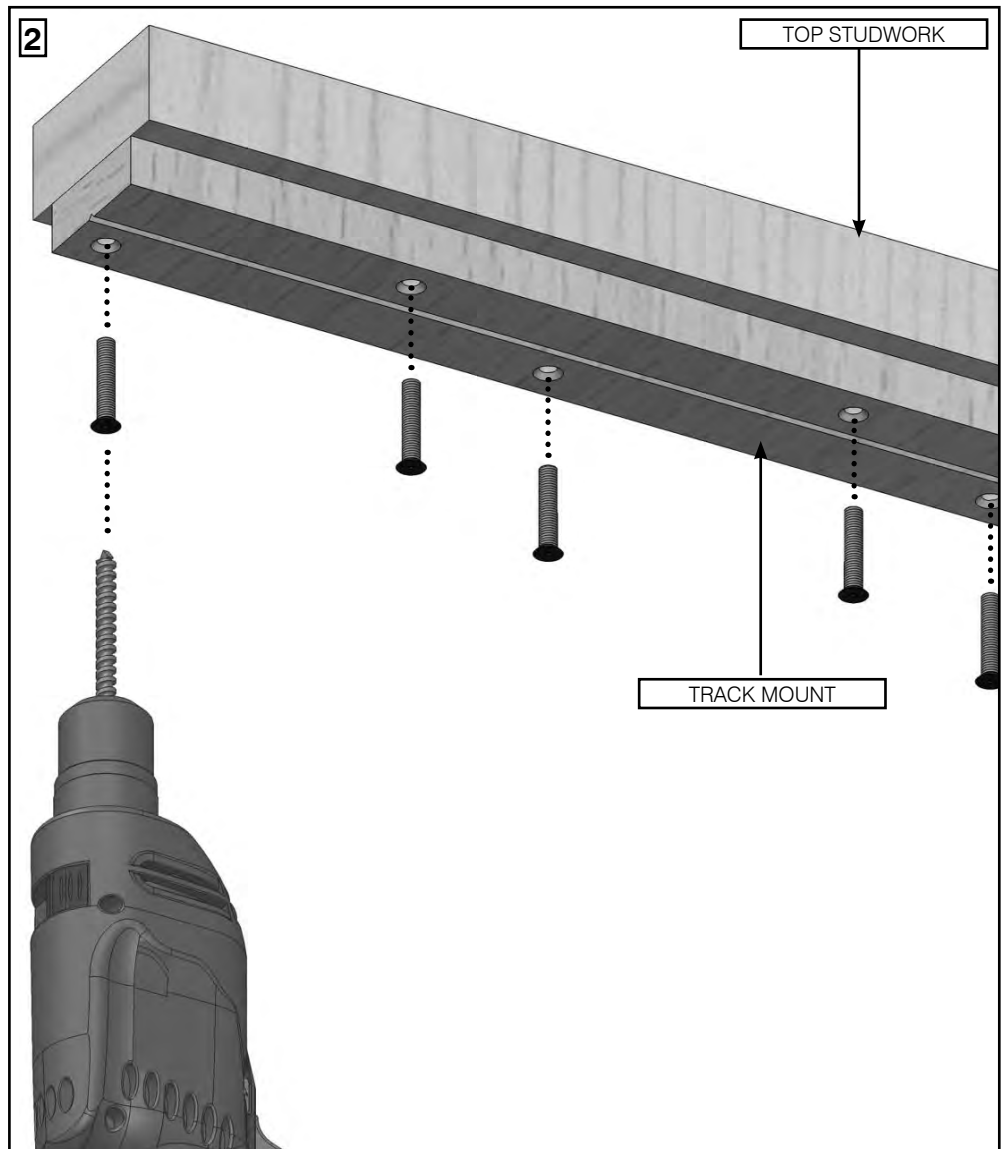
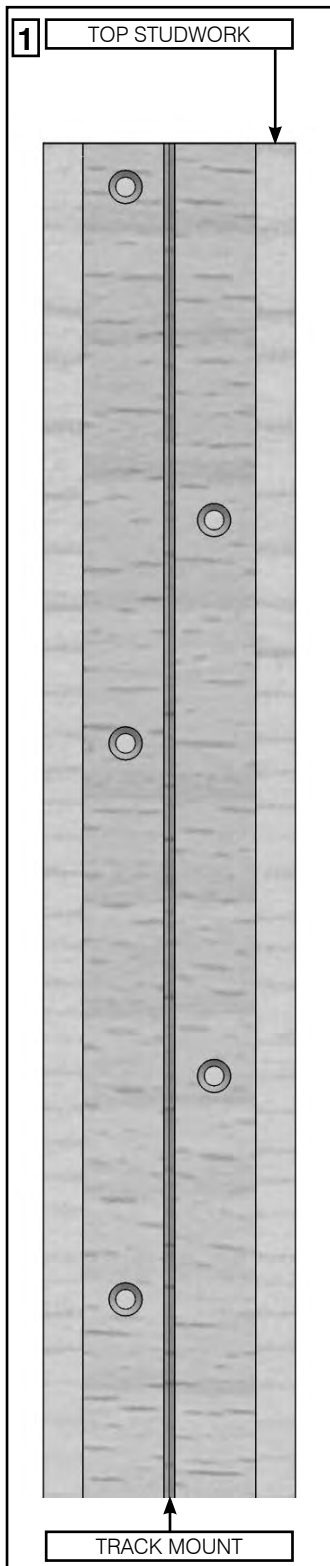

1. Cut the plywood track mount to the width of your horizontal studwork / support frame.
2. Position the track mount in the centre of the top horizontal studwork timber / support frame.
3. Pilot drill and screw through both sides of 'V' Shaped Groove and ensure screw heads are fully sunk into the wood **(Screws not supplied)**.

2. ALUMINIUM TRACK

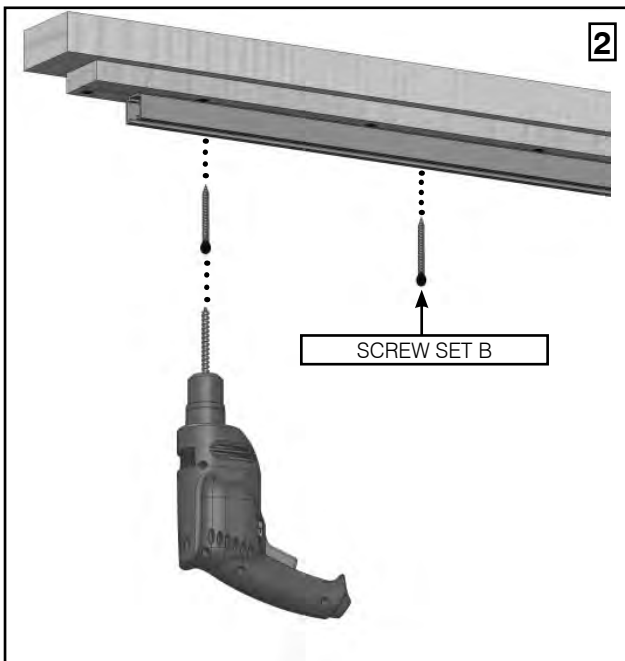
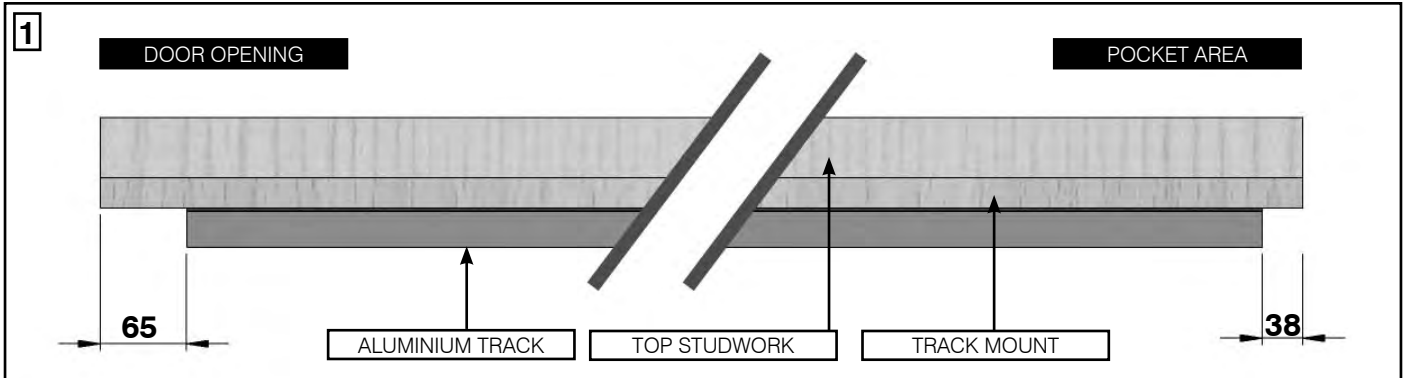

1. Cut the aluminium track to the width of your horizontal studwork, minus 103mm. Position 65mm in from doorway vertical stud to allow for the end block.
2. Using '**Screw Set B**', fix through the holes in the aluminium track into the 'V' shaped groove in the track mount beneath it.

TRACK SHOULD BE WIPED CLEAN TO REMOVE ANY CONTAMINANT

If using the DOUBLE DOOR KIT, position the end block centrally into the plywood track mount and screw into the 'V' shaped groove with '**Screw Set D**'.

Measure the aluminium tracks from the inside edge of the end block to the stud, minus 38mm.

This gap will be for the rear trolley catch. Fix into the 'V' shaped groove in the plywood track mount with '**Screw Set B**'.

At this point remove the end block as entry to the tracks is required for installation.

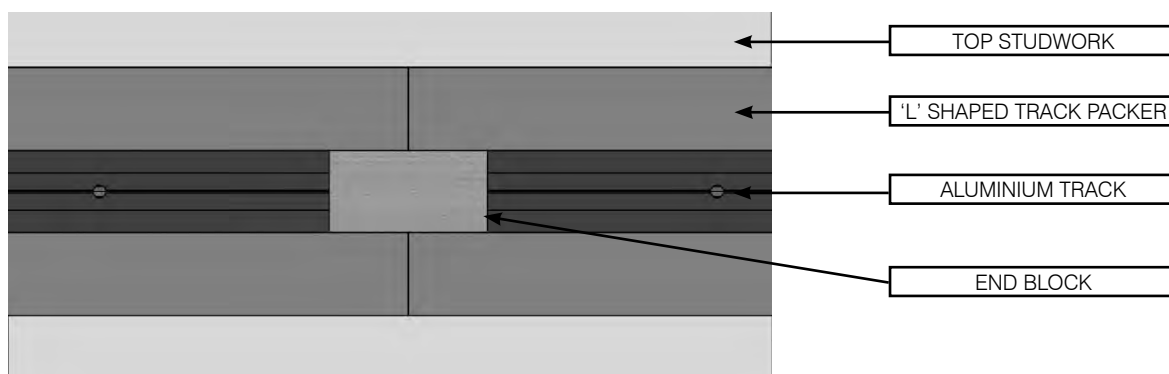

3. SOLE PLATE

1. Position the leading edge of the sole plate (Door panel width plus 24mm) away from the inside face of the rear studwork.

Sole Plate may need cutting down depending on door size.

2. Cut away the thin strip of metal at the leading edge of sole plate to allow later installation of the door guide.
3. Butt the sole plate centrally to the studwork at the back edge of the pocket.
4. Plumb true to the aluminium track above and secure the plate to the floor with appropriate fixings (**not supplied**).

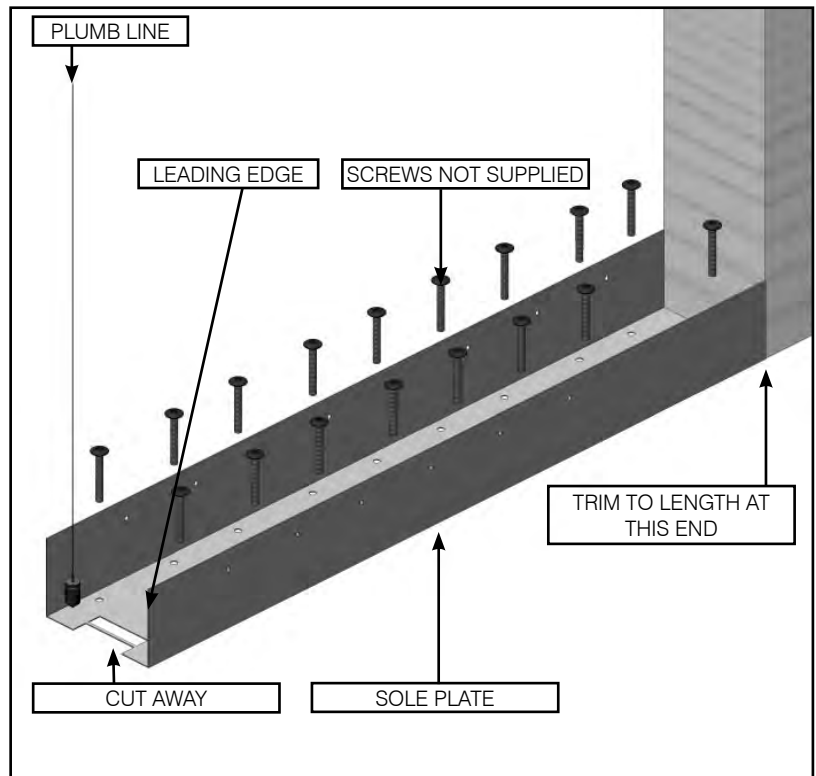

4. 'Z' PANELS

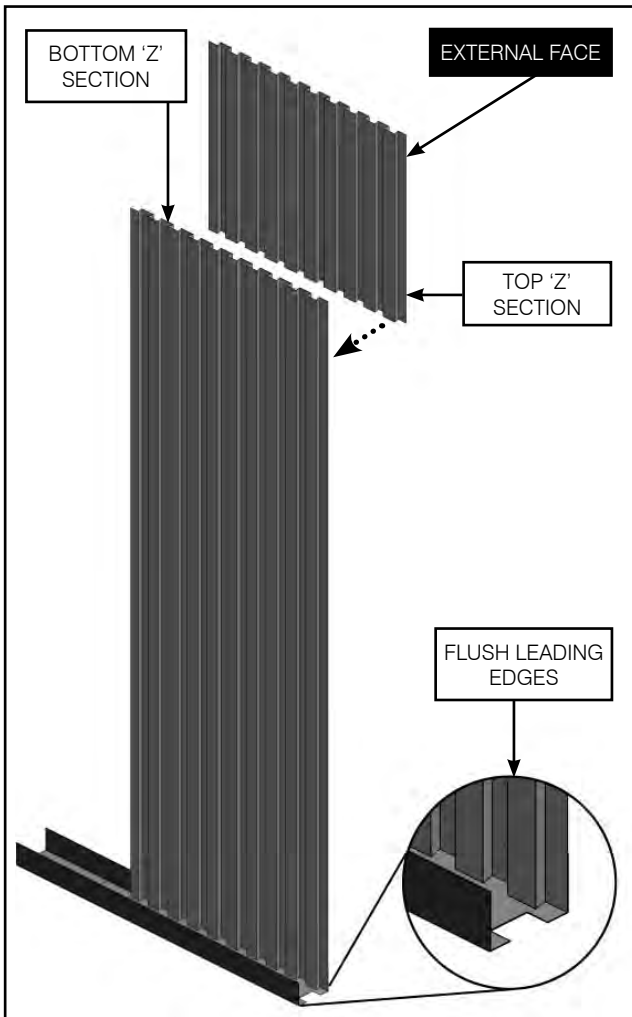

1. Adjust the 'Z' Panels to desired height (inside surface of sole plate to underside of top studwork).
2. Position the bottom 'Z' Panel inside the sole plate so that both leading edges are flush.

Make sure the top 'Z' section is on the outside of the pocket.

Please Note: With wide and intermediary kits a second set of metal 'Z' panels are supplied. The second set should be installed level with the rear of the sole plate. On the intermediary kits the narrow sheets should be to the rear of the pocket

IF YOU ARE USING A REINFORCING KIT - PLEASE REFER TO INSTRUCTIONS 003-285 AND INSTALL IT AT THIS POINT BEFORE SCREW FIXING THE 'Z' PANELS

PLEASE NOTE: TOP 'Z' SECTION IS ON THE OUTSIDE OF THE POCKET

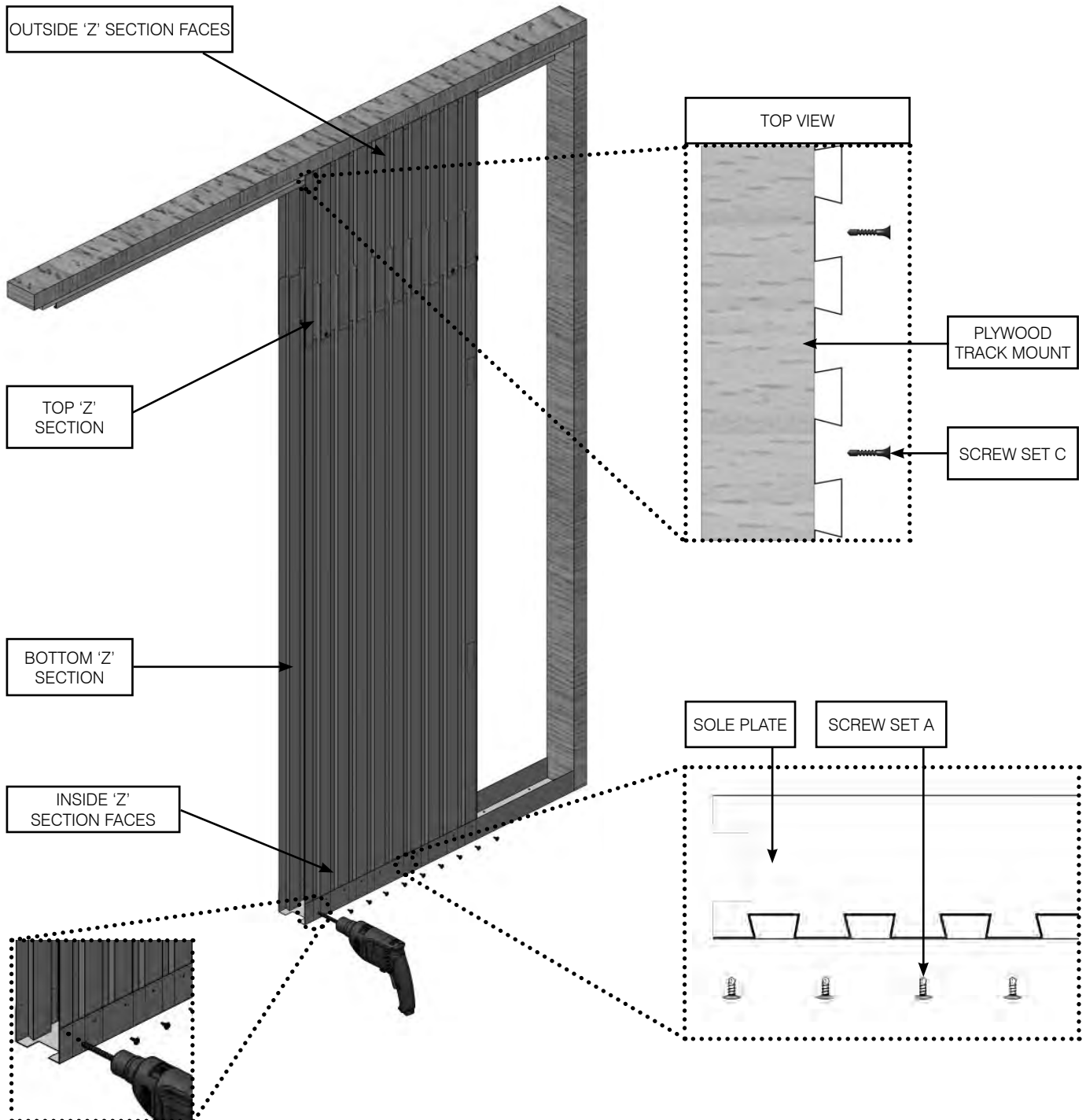

Ensure panels are level and then fix with screws.

1. Fix top 'Z' Section to plywood track mount with '**Screw Set C**'.
2. Fix bottom 'Z' section to sole plate with '**Screw Set A**'.
3. Drill a hole at the front edge of the sole plate through the 'Z' Panel on either side and fix with '**Screw Set A**'.

5. PANEL JOINING

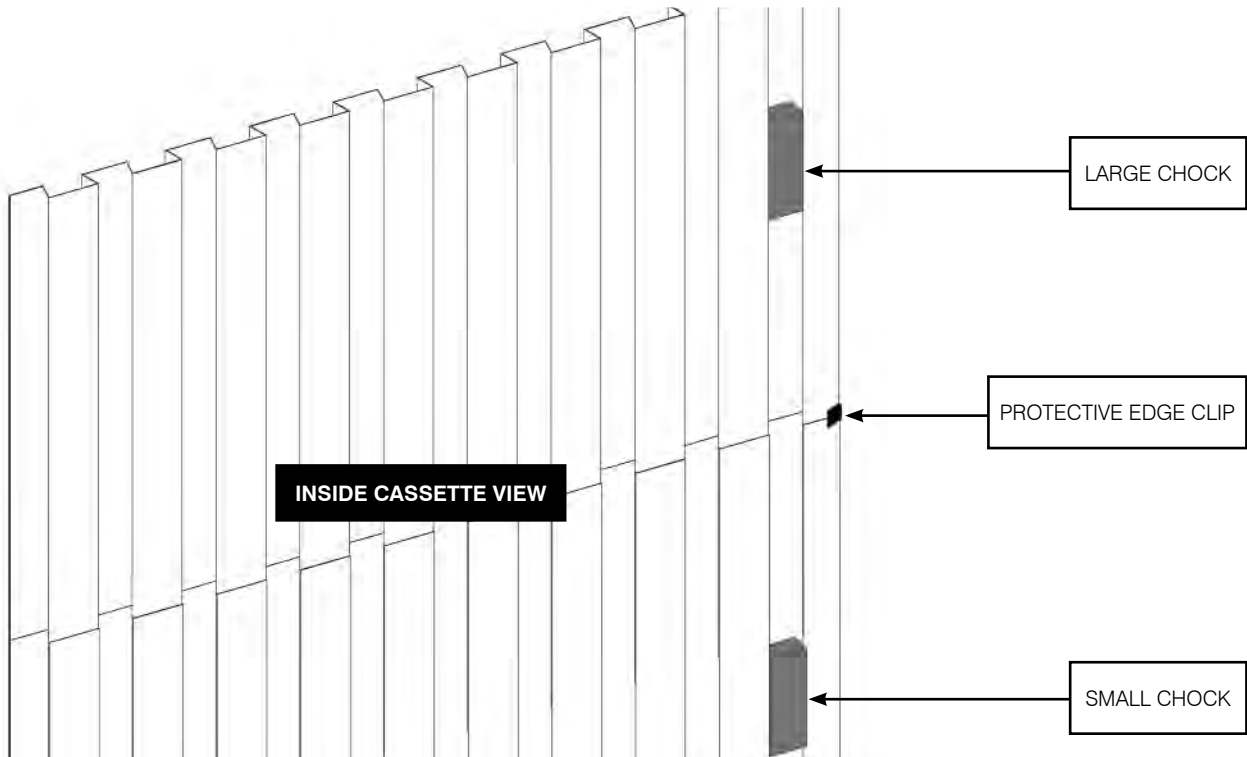

At the back of the pocket, place the protective edge clip onto the 'Z' section, covering where the panels join.

In the last 'Z' section slot towards the back of the inside pocket, push the large chock into the top 'Z' section and the two small chocks into the bottom 'Z' section. This pushes the edge outwards so the door does not snag on it when closing.

For intermediary and wide kits, fit the chocks in the first and last slot in the rear 'Z' sections as detailed above. Fit protective edge clips to all joints on rear panels.

Repeat stages 4 - 6 on the other side of the pocket.

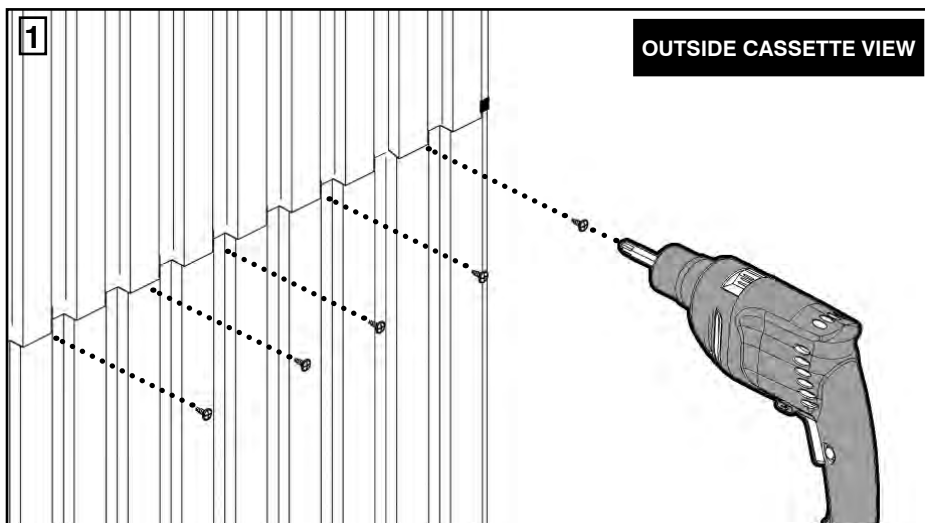

1. Screw through from outside to join panels together in five locations using '**Screw Set A**' (pilot holes not required).

ENSURE WHEN SCREWING THE TWO SHEETS THEY ARE STRAIGHT AND DO NOT BECOME BOWED AS THE SCREW PUSHES THROUGH

6. DOOR GUIDE

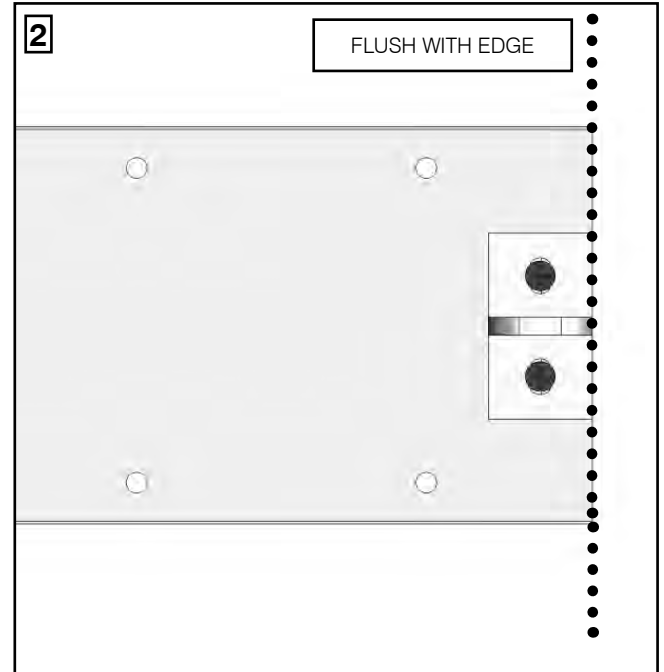
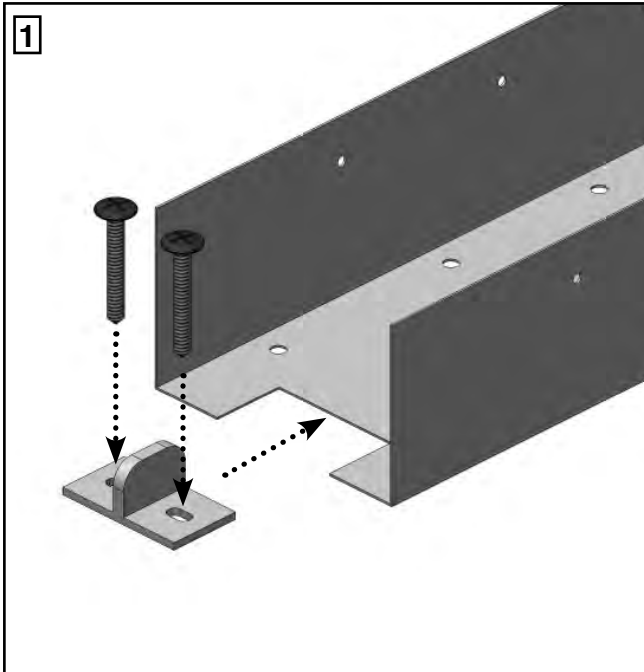

1. Fix the metal floor guide into the sole plate by inserting it into the pre-cut area.
2. Ensure it is flush against the sole plate edge and then scew fix firmly into the floor **(screws not included)**.

7. BOTTOM DOOR GROOVE

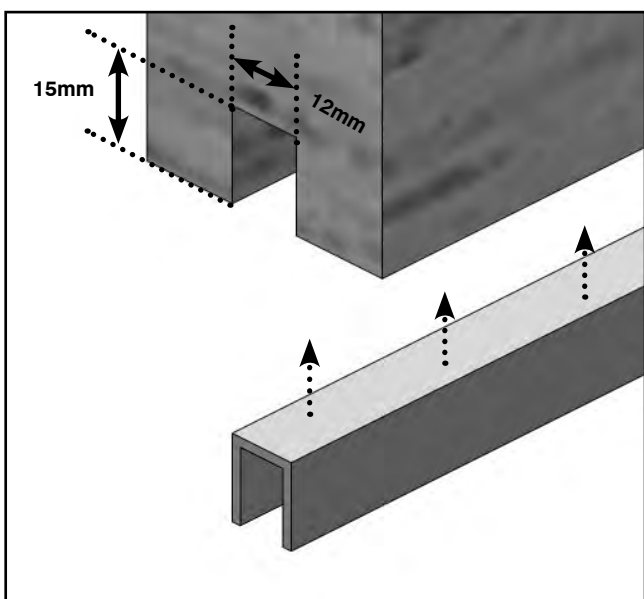

1. Cut a groove in the bottom face of the door to suit the plastic channel which the floor guide runs in.

Ensure when cutting the groove it is centralised along the width of the door.
2. Bond or Pin the channel into the cut groove ensuring the metal floor guide can move freely within it.

8. 'L' SHAPED TRACK PACKERS

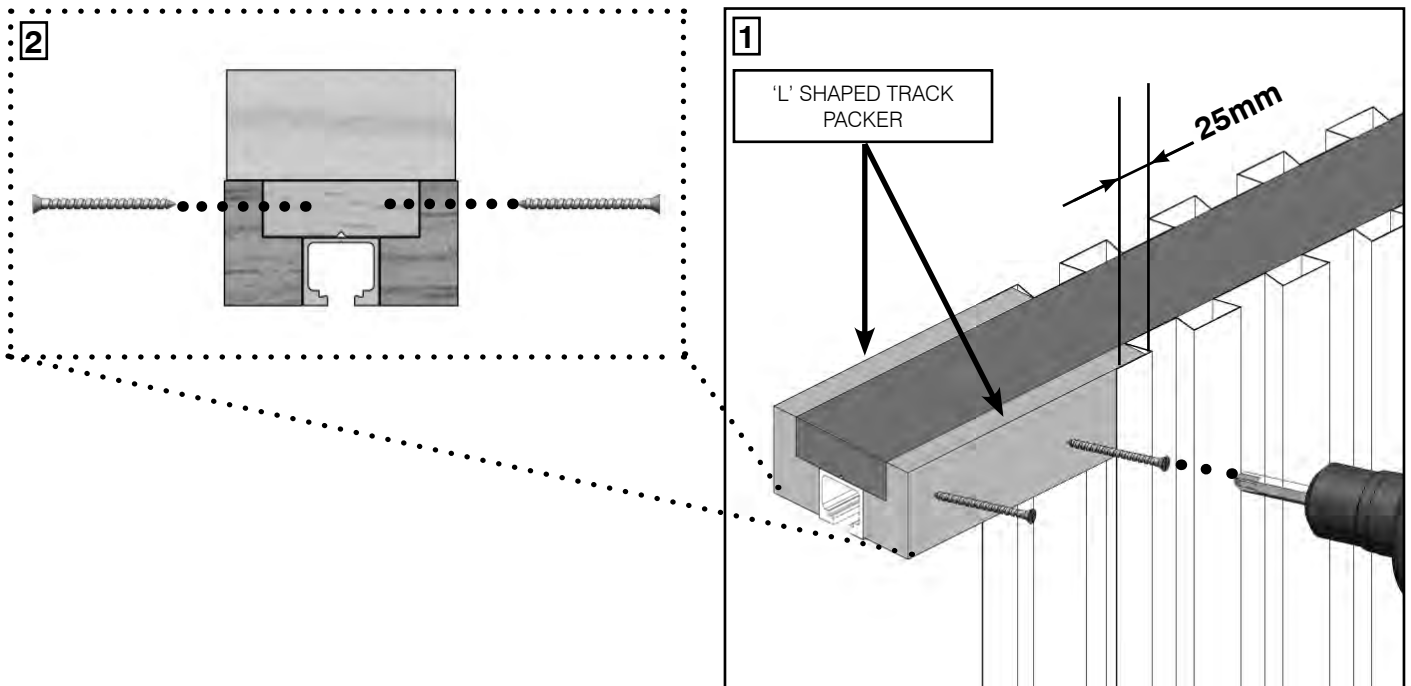

1. To cut the 'L' Shaped track packers, measure remaining door opening width and add 25mm so the wood will go behind the 'Z' section edge.
2. To secure the 'L' shaped packers, first pilot and countersink a series of holes in their length, approximately 300mm apart. Screw surely through into the plywood track mount using **'Screw Set E'**.

9. JAMB FITTING - CASSETTE JAMBS

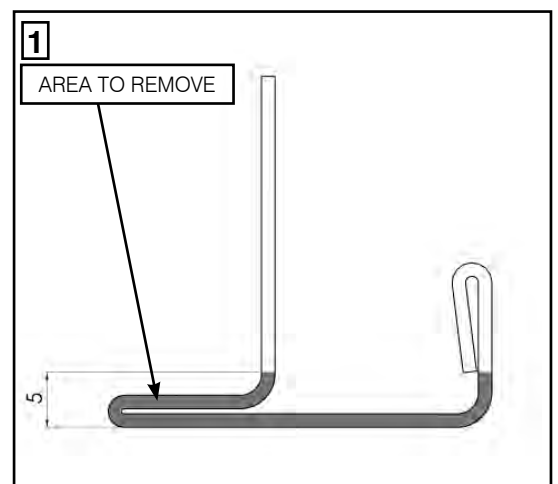
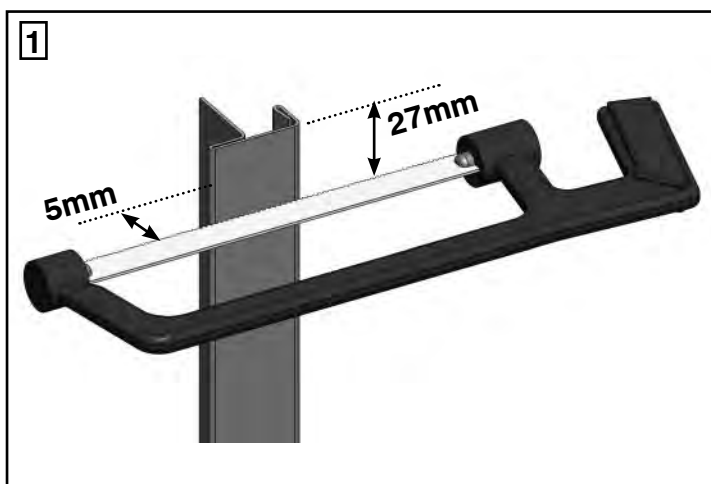

1. To begin, using a sawing or cutting tool, cut the cassette jamb 27mm from the top, cutting 5mm deep.

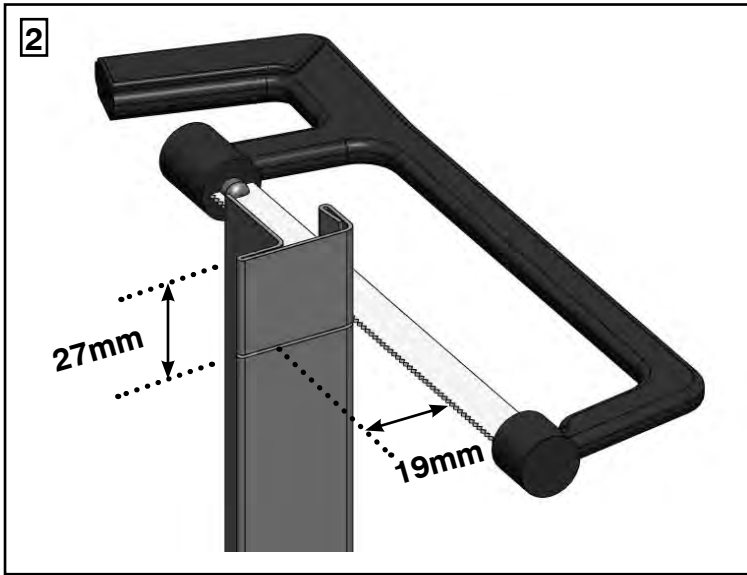

2. Make the second cut, 27mm deep, 19mm inwards

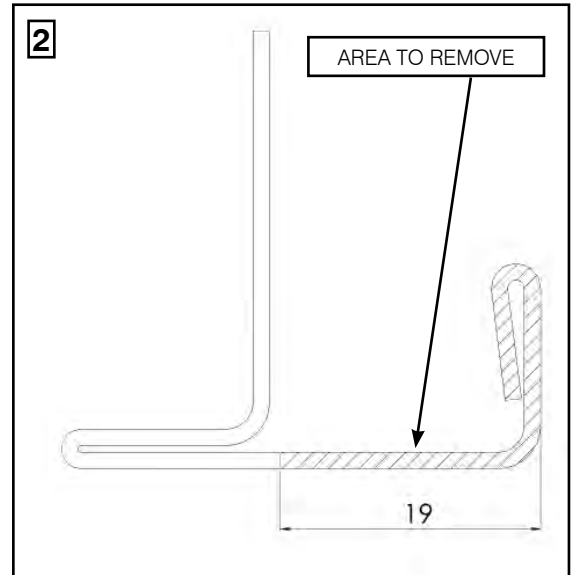

3. Make the final cut, 27mm deep, completing the cutting and removing the cut out piece.

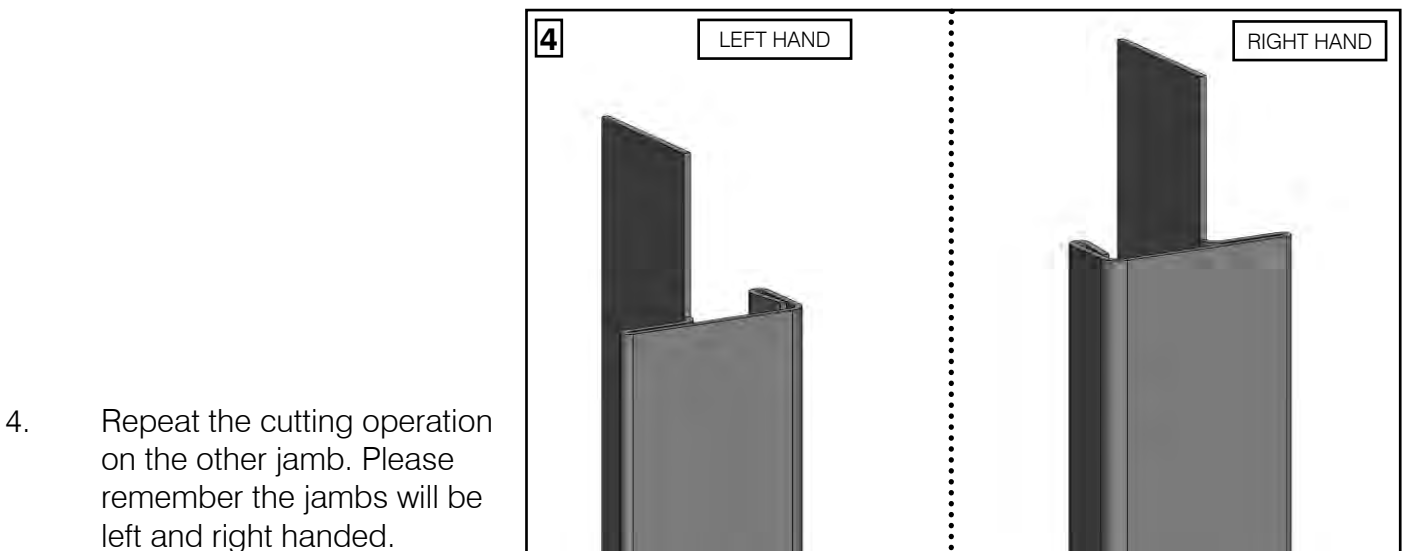
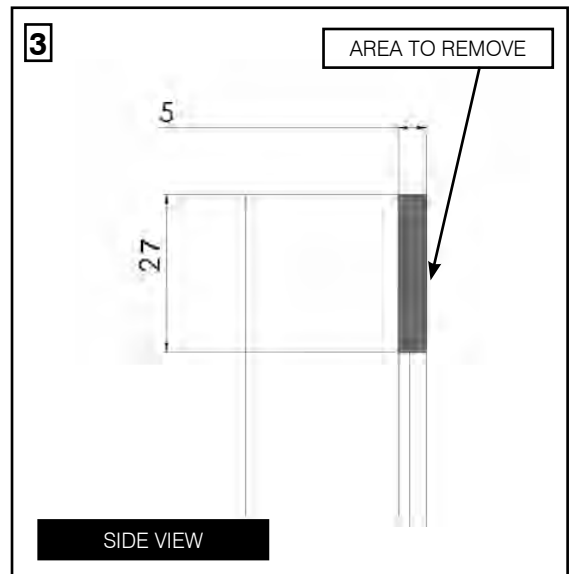

4. Repeat the cutting operation on the other jamb. Please remember the jambs will be left and right handed.

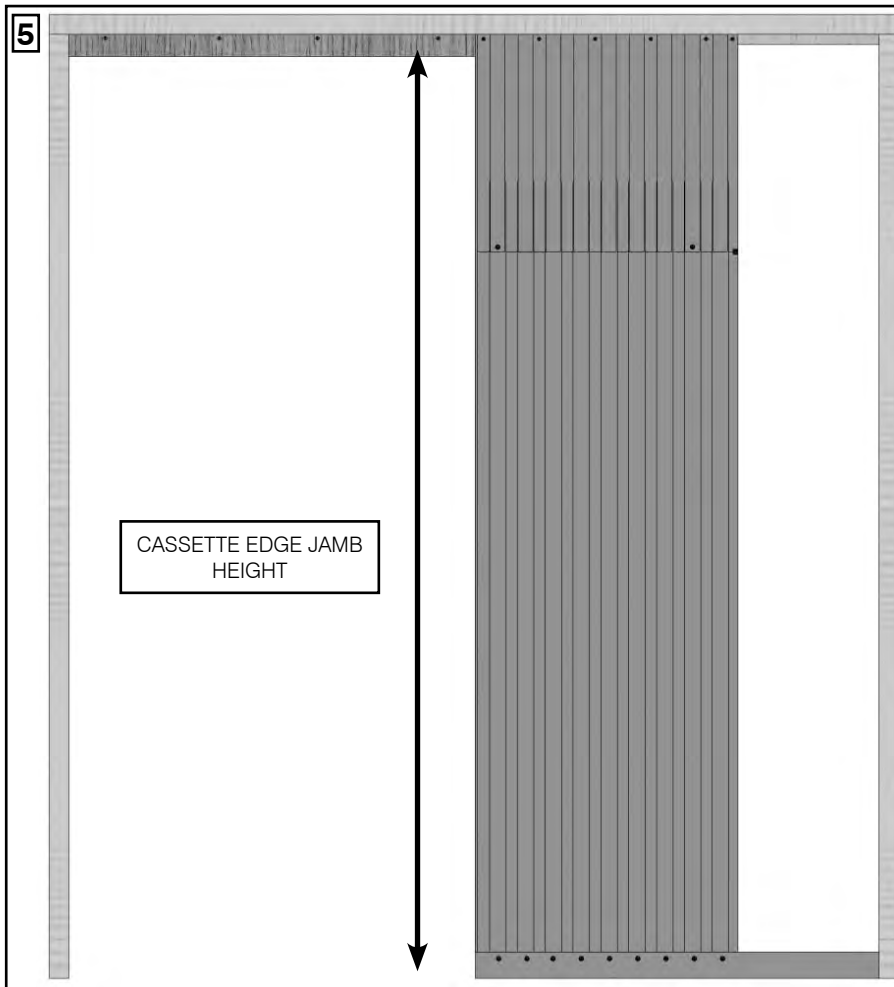

5. Cut the jamb to the correct height from the floor to the underside of the 'L' shaped packers.

Cut from the opposite side to the previous cutting operation.

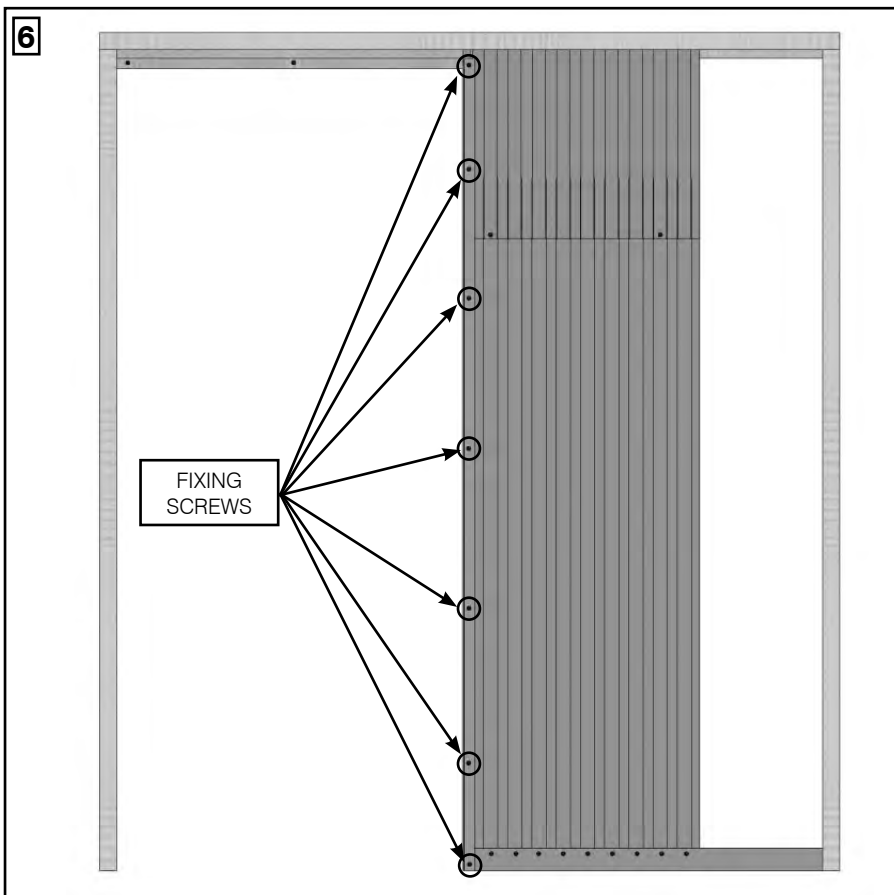

6. Fix the jambs onto the leading edge of the pocket. Secure with adhesive and **'Screw Set A'** in top and bottom positions, and then every 400mm (pilot hole drilling not required).

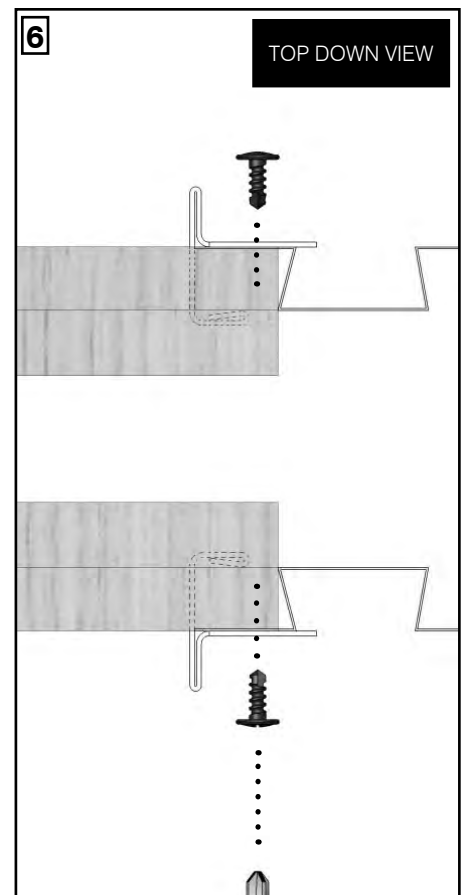

10. JAMB FITTING - FRONT EDGE JAMB

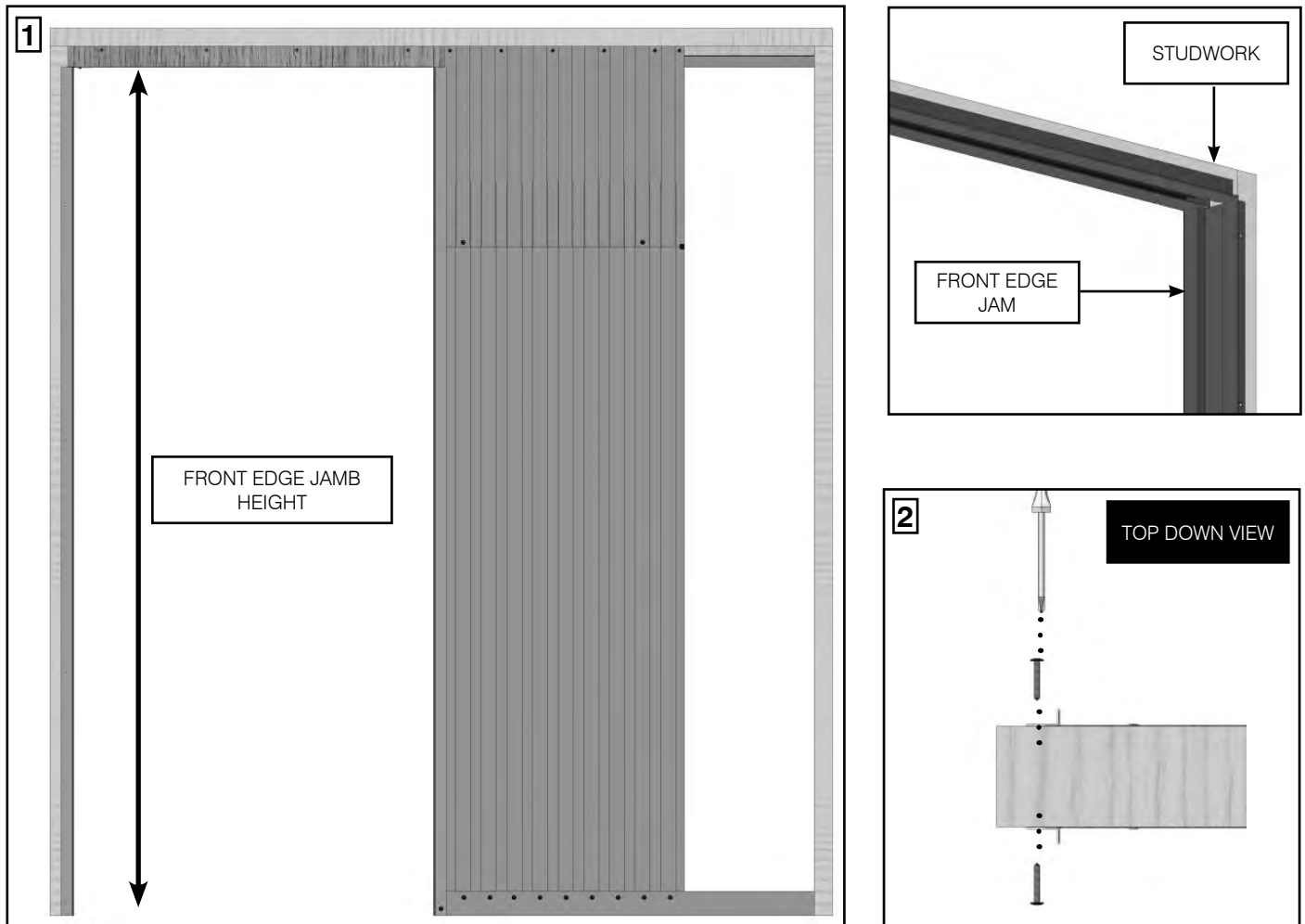

1. Cut the jamb to the correct height from the floor to the underside of the 'L' shaped packers.
2. Pilot holes into the vertical stud on both sides and then fix the jamb with screws and adhesive.
(Screws not supplied).

11. JAMB FITTING - HEAD JAMB

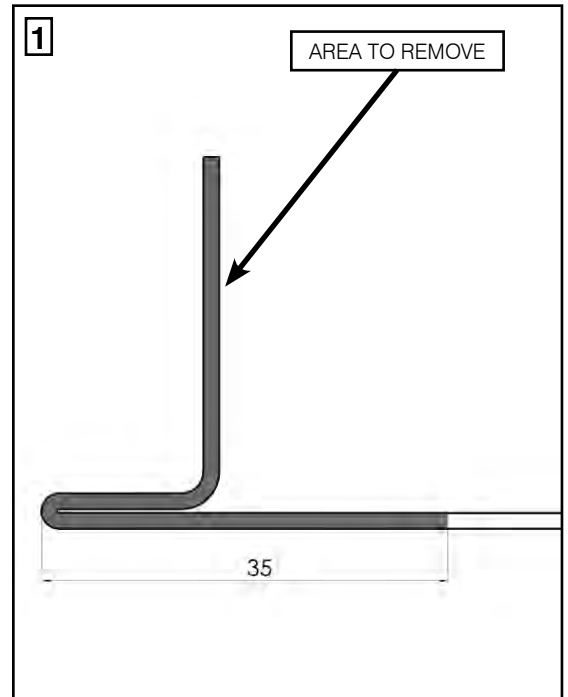
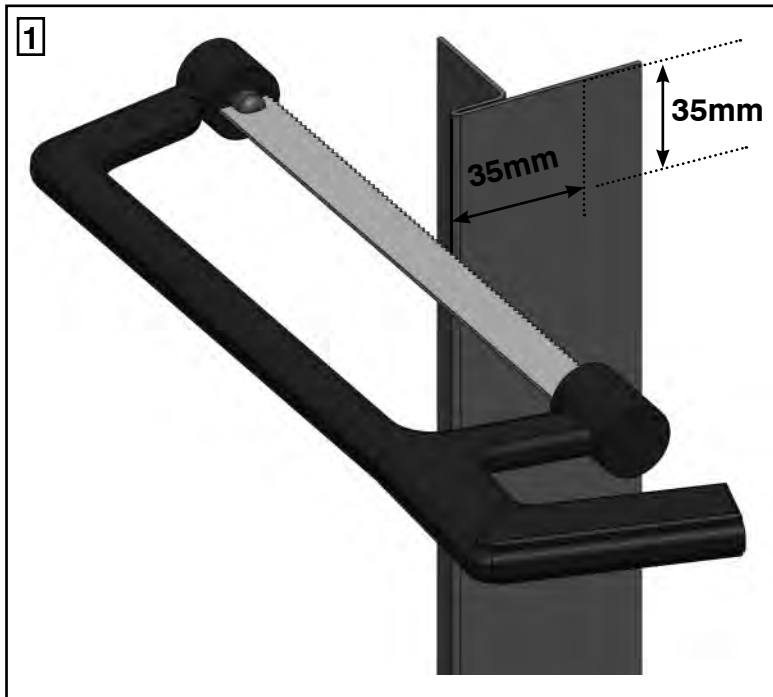

1. To begin, using a sawing or cutting tool, cut the head jamb 35mm from the top, cutting 35mm deep.

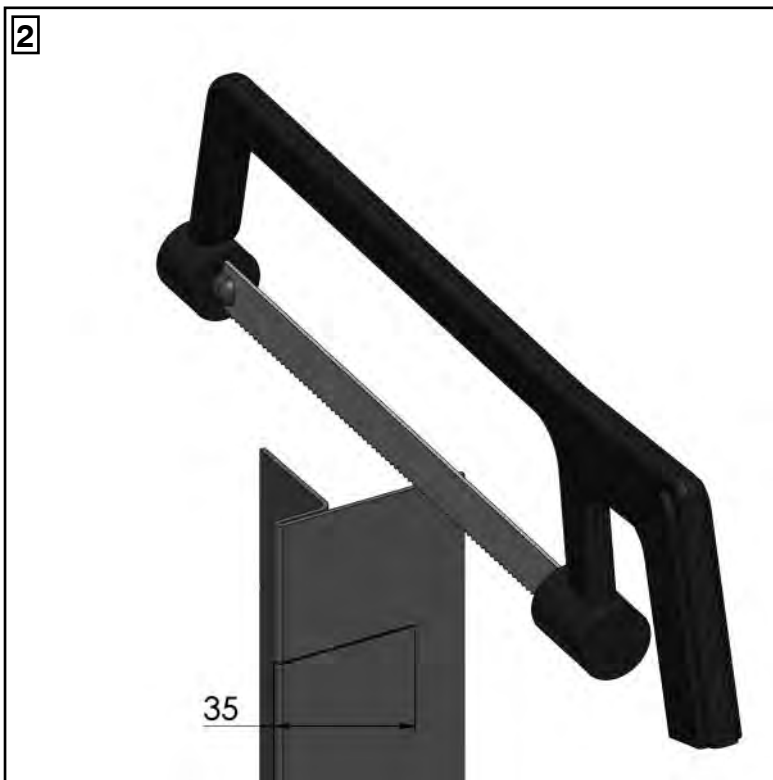

2. Make the second and final cut, 35mm down, 35mm inwards.

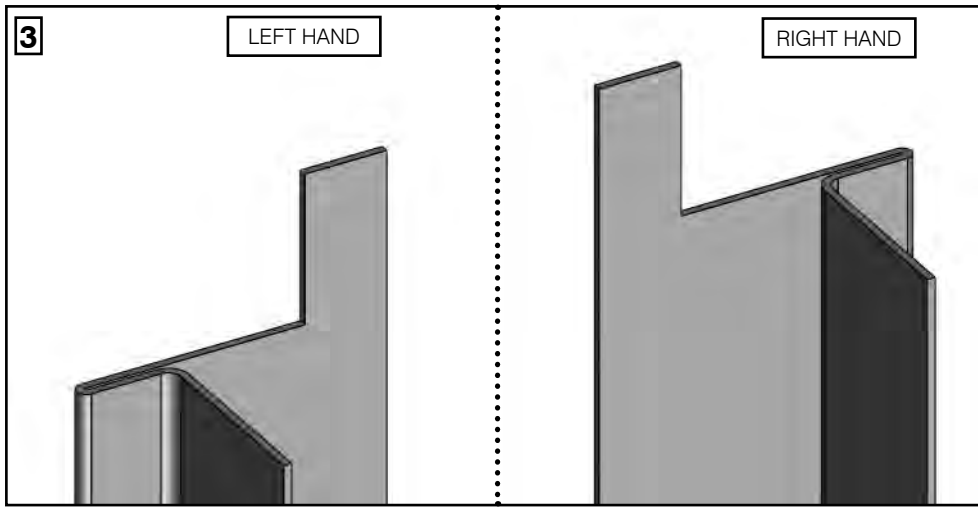

3. Repeat the cutting operation on the other jamb. Please remember the jambs will be left and right handed.

4. Cut the head jambs to fit the remaining door opening width. Screw into 'L' Shaped track packer with **'Screw Set A'**.

Cut from the opposite side to the previous cutting operation.

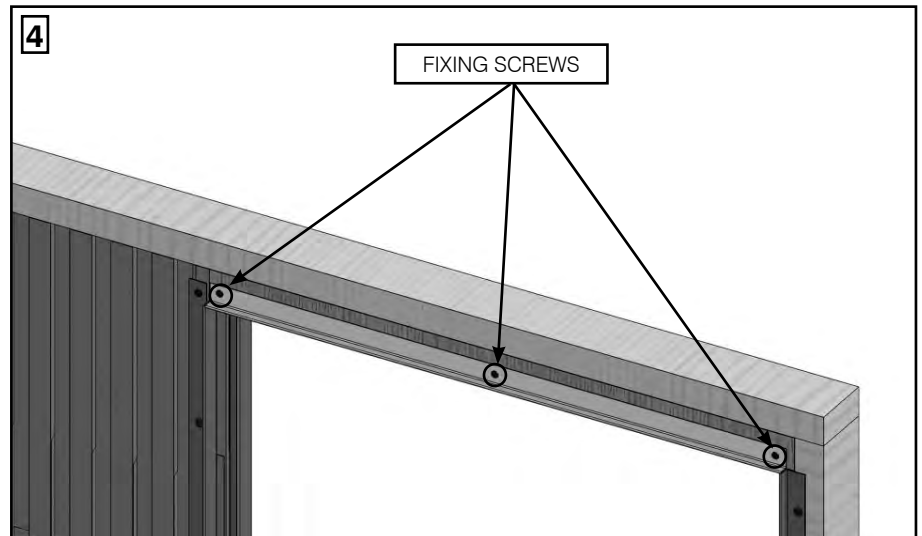

12. DOOR ASSEMBLY

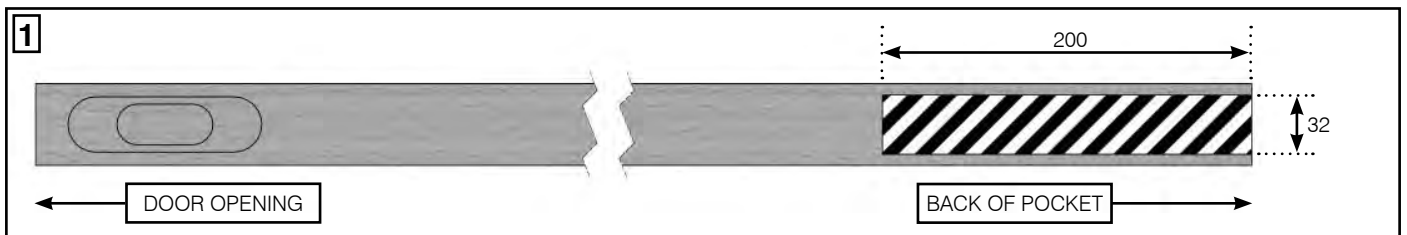

1. Cut the back of door mortise in the top of the door (200 x 32 x 29.5mm) and fix the bracket into this mortise (screws not supplied).

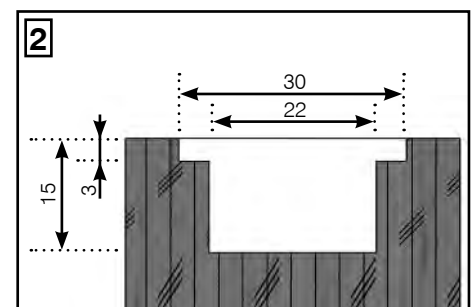
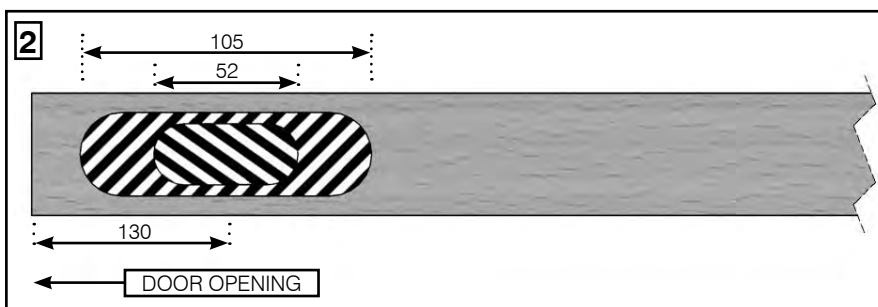

2. Cut the front of door mortise in the top of the door in two depth stages as pictured. Fix the cover over the mortise (screws not supplied)

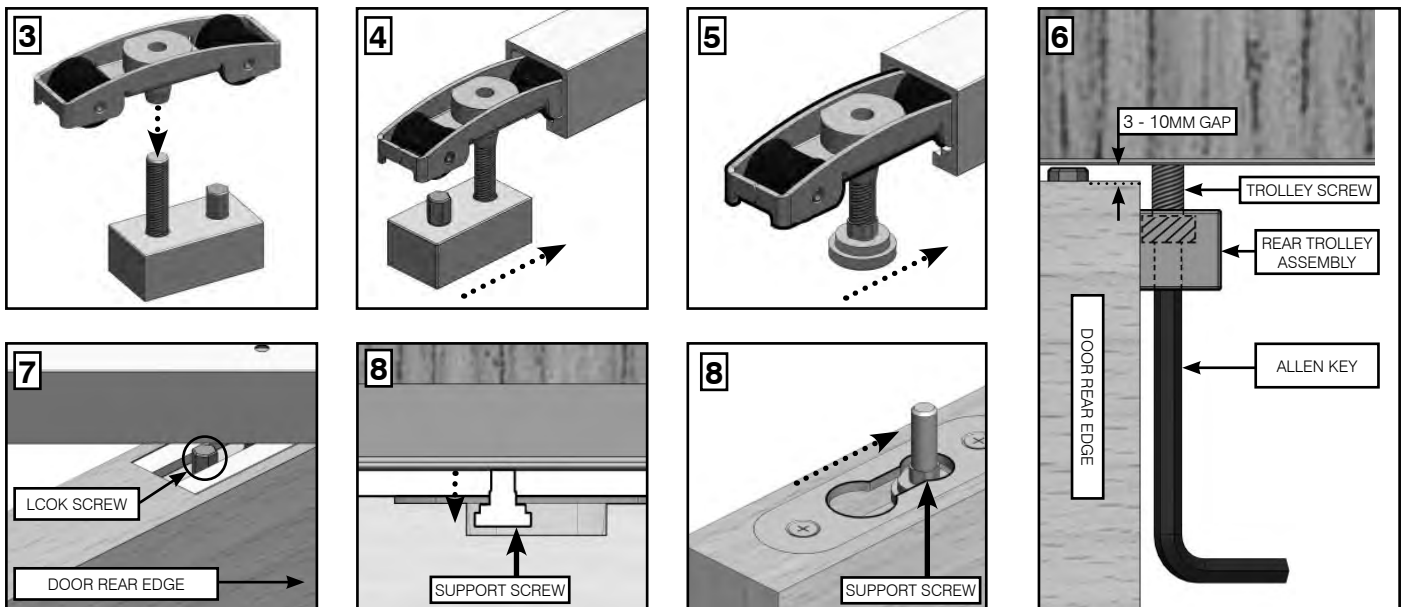

3. Firstly, assemble the rear trolley assembly by screwing the trolley wheels onto the trolley body.
4. Slide the rear trolley into the aluminium track.
5. Screw support screw into second trolley and slide assembled trolley into the aluminium track.
6. At an angle of approximately 45 degrees, slide the door partially onto the rear trolley assembly and adjust the trolley screw to achieve a gap at the top of the door between 3 and 10mm
7. Slide door fully onto the trolley, tightening the lock screw to secure. Pivot door inwards and slide into pocket, ensuring correct location with floor guide.
8. Position front support screw above keyhole plate. Lift front edge of door up allowing support screw into large keyhole. Push the screw across into the smaller keyhole and lower the door. To adjust this screw to level the door, you must take the weight off the door before using a spanner to make adjustments.

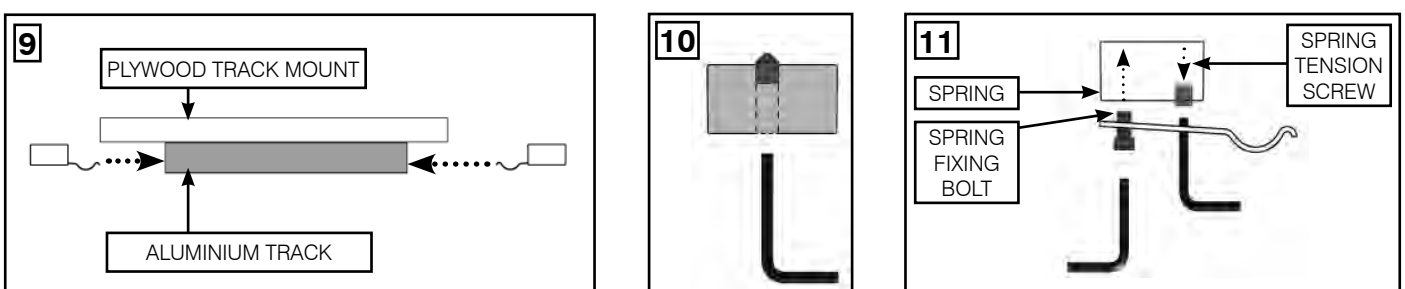

9. Place trolley catches in front and back of aluminium track.
10. Fix trolley catches in required positions within the aluminium track by removing the spring giving access to the centre hole locking grub screw. A 3mm allen key is required.
11. Replace the spring and adjust the clamping bolt to the desired tension to hold the trollies in place using an M5 allen key.

Test to see if door runs smoothly and that the trolley catches are in a suitable position. If not, adjust trolley assemblies until they are both at the same height.

IF USING TOUCH LATCH, DISCARD THE REAR TROLLEY CATCH

13. END BLOCK

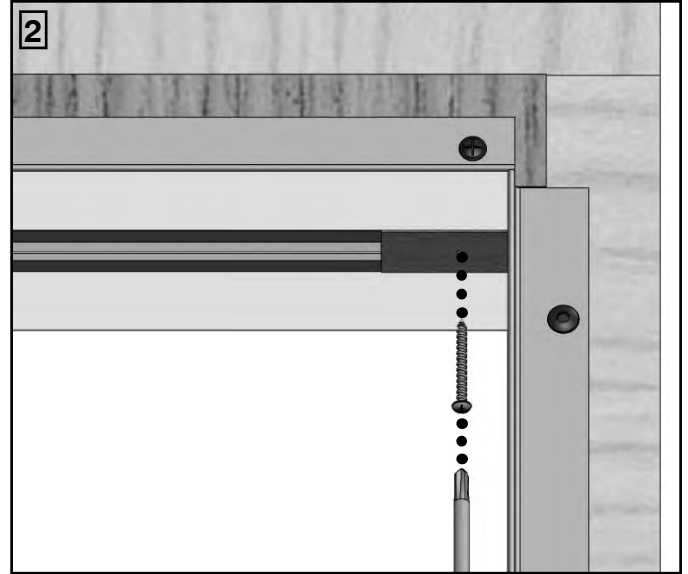
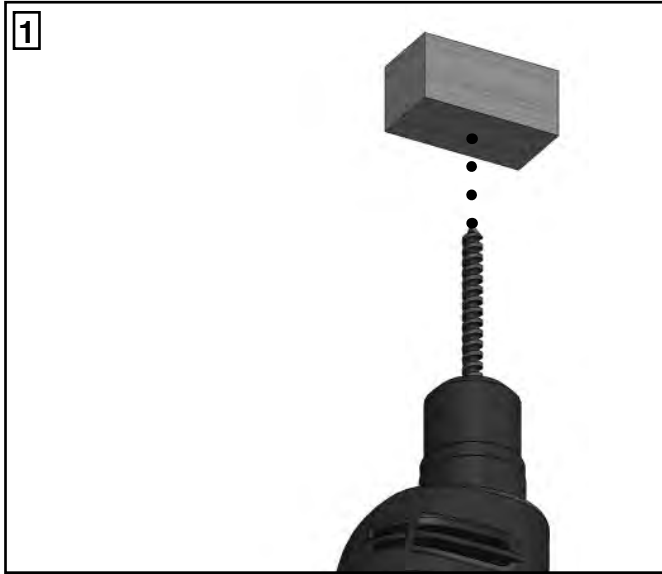

1. Pilot drill a hole in the wooden end block using a 2.1mm drill bit. Drill the hole in the centre of the block.
2. Using the newly made hole, with 'Screw Set D', screw into the 65mm spacing left between the aluminium track and the studwork. Make sure the end block is butted against the track.

(FOR DOUBLE DOORS, PLACE END BLOCK IN CENTRAL SPACING AS DETAILED IN STEP 2).

14. SEALS

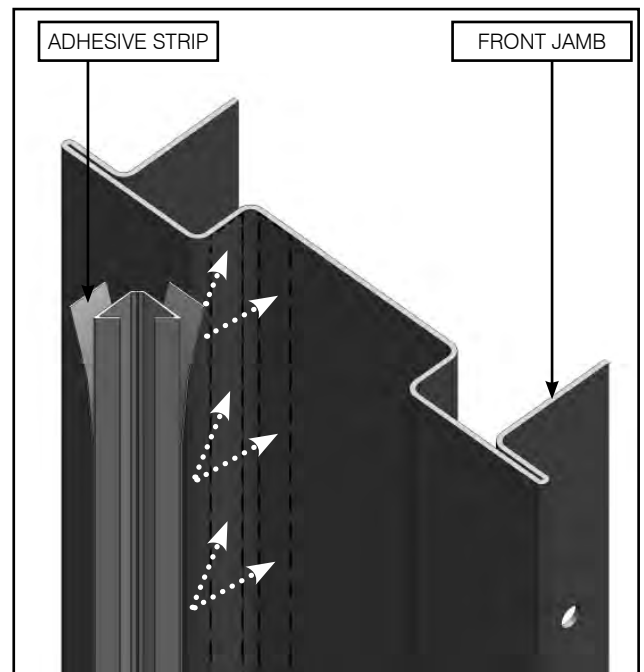
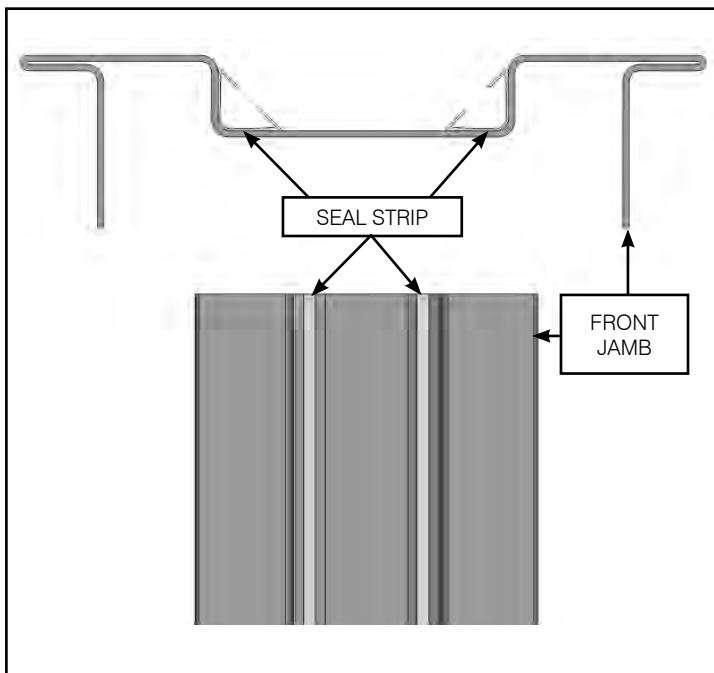

1. Cut the seals to the length of the front jamb. Peel back the adhesive strips and push in the two corners of the jamb.

15. PLASTERBOARD

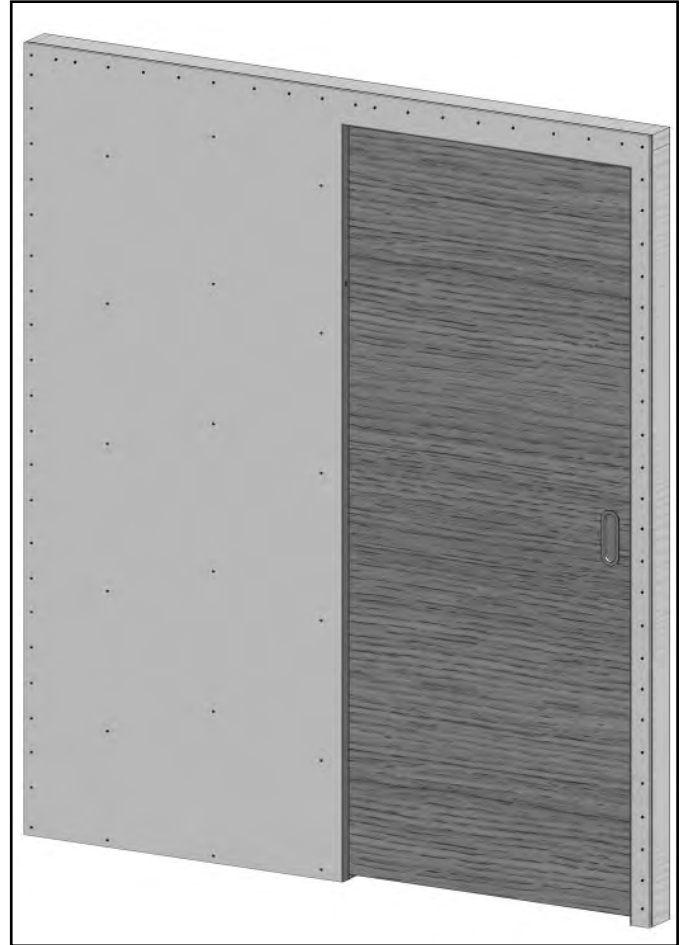
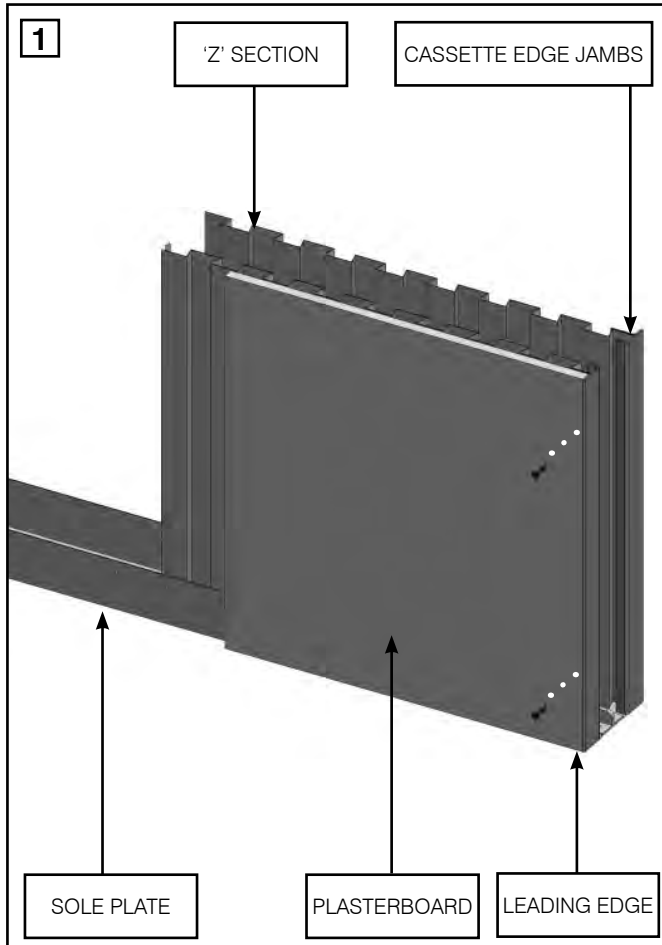

1. Clad the kit in 12.5mm thick plasterboard or other board material, ensuring that it finishes level and tight to the leading edge of all jambs.

When positioned correctly, use an adhesive and screw fixings / nails to secure to the stud frame (**fixings not supplied**).

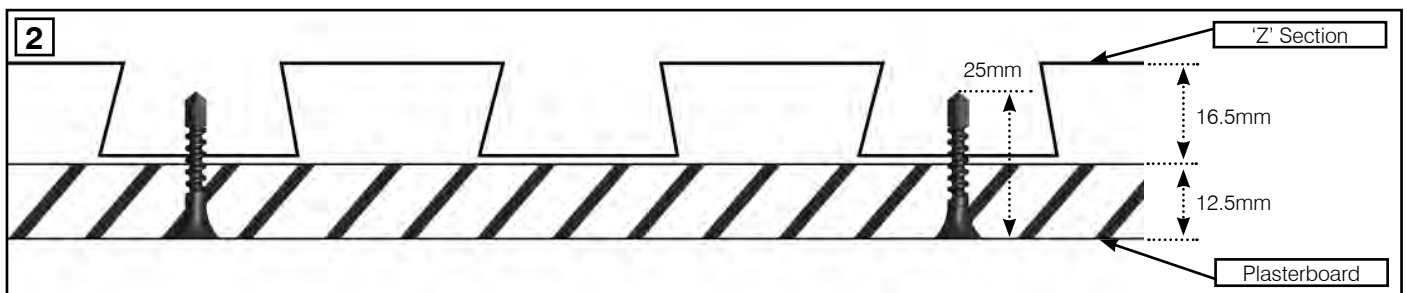

2. It is also required to screw fix the plasterboard to the 'Z' Section panels behind it. Ensure you drill pilot holes which pass through the plasterboard and 'Z' Section/s before screwfixing. **Use a 25mm screw** so it will pass through the Plasterboard and 'Z' Section (as pictured), but not into the path of the door (**fixings not supplied**).