



## Fire-Resistant Glass Range

- Pilkington Pyrostop™
- Pilkington Pyrodur™
- Pilkington Pyroshield™



# Trust. In a fire it's more important than ever.

## **Burning Questions, Brilliant Solutions.**

Specifying the right fire-resistant glass is a crucial decision.

It's important to know that the product specified and installed will perform as intended in a fire. That's why you should specify the Pilkington range. Pilkington has consistently invested in the development and testing of its range of fire-resistant glass so you know you can rely on it.

When it comes to fire-resistant glass, Pilkington is the name to trust. We have been at the forefront of fire-resistant glass innovation since 1896 when we first introduced wired glass. Our objective is to continue to offer high performance and high quality products that can be relied upon in a fire. The current Pilkington range of fire-resistant glass is designed to do exactly that, meeting the UK regulatory requirements for integrity only or integrity with insulation.

Choosing the right glass for the right application is made easier with Pilkington. Pilkington **Pyrostop**<sup>™</sup>, Pilkington **Pyrodur**<sup>™</sup>, Pilkington **Pyrodur**<sup>™</sup> Plus and Pilkington **Pyroshield**<sup>™</sup> are designed to provide outstanding fire performance with impact safety (where applicable). They can also be combined with other products from the Pilkington range to provide additional features such as energy management or noise control. With our ongoing commitment to testing, technical innovation, quality, reliability and consistency, you can put your trust in Pilkington.

At Pilkington we believe that where fire safety is concerned, standard fire tests alone are not sufficient, nor are they the only way to substantiate performance claims. We devote a lot of effort to product design, production control, R&D, product evaluation and internal testing to ensure that the products consistently live up to performance demands.

To give you absolute confidence, we also continually put our products to the test, in a wide variety of sizes, configurations, applications and glazing systems.

Our products are third party audited and certified at the point of manufacture under independent schemes. We also carry out our own internal product testing programmes for fire performance, including impact safety, solar and acoustic testing, backed up by a major investment in technical resource that is only possible from a global company of international renown and experience.

The pan-European standards are replacing national standards. Pilkington has been supportive in the development of these standards, and our product range offers high and consistent levels of fire performance fully in line with the new standards.



Pilkington **Pyrostop**<sup>™</sup>  
National Gallery, Dublin.

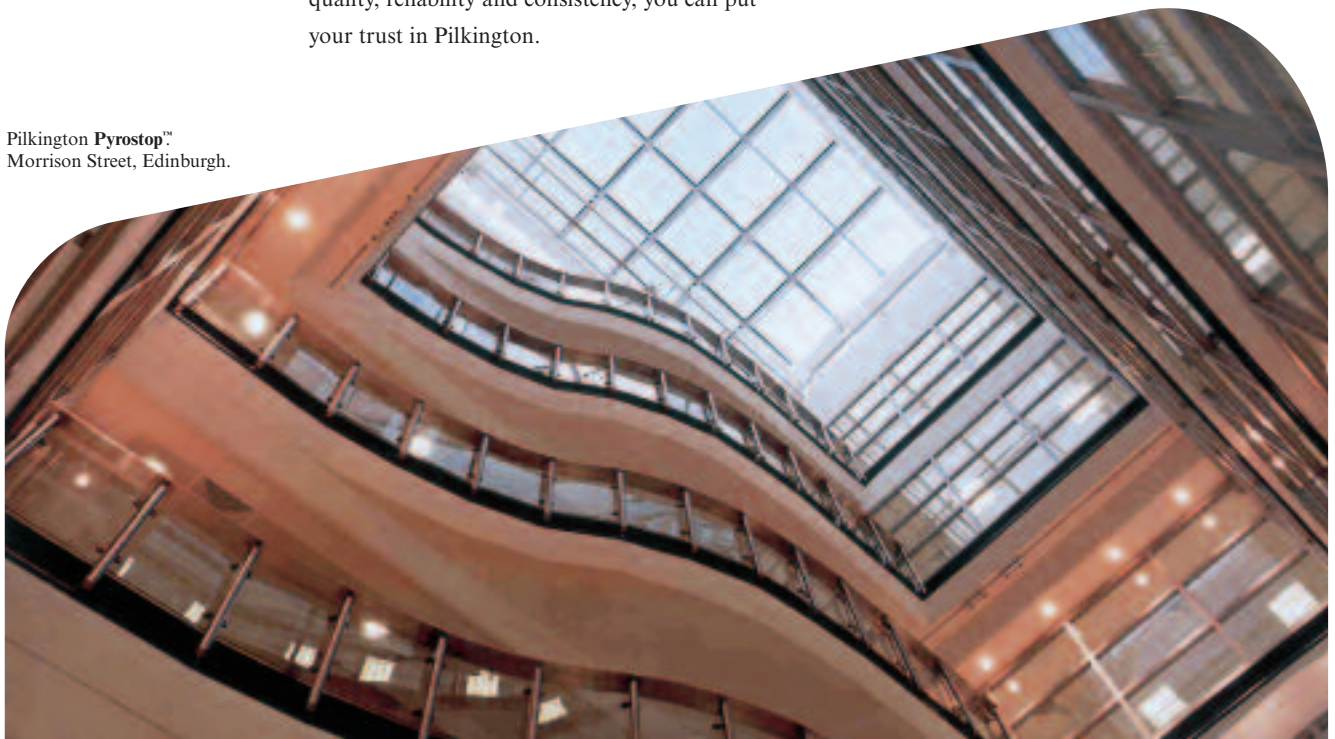

Pilkington **Pyrostop**<sup>™</sup>  
Morrison Street, Edinburgh.

# Fire Product Classification and Performance Definitions

## Integrity

The ability of a specimen of a separating element to contain a fire to specified criteria for collapse, freedom from holes, cracks and fissures, and sustained flaming on the unexposed face.

## Insulation

The ability of glazed screens or doors to limit the temperature rise on the non-fire side to an average of no more than 140°C and in any one position by no more than 180°C .

## Radiant Heat

The ability of the element of construction to reduce the probability of transmission of fire as a result of significant radiated heat, either through the element or from its unexposed surface to adjacent materials on the non-fire side.

## Classification

EN 13501-2 Fire classification of construction products and building elements.

Part 2: Classification using data from fire resistance tests, excluding ventilation services.

UK regulations have previously classified products in terms of integrity or integrity and insulation.

The European definitions will be as follows:

- E Integrity
- I Insulation
- W Radiation

Therefore, example classifications may become:

- E 30 = 30 minutes Integrity
- EI 60 = 60 minutes Integrity and 60 minutes Insulation

## Relevant Fire Test Standards

BS 476 Fire tests on building materials and structures.

Part 20: General requirements.

Part 22: Methods for the determination of the fire-resistance of non-loadbearing elements of construction.

BS EN 1363 Fire resistance tests.

Part 1: General requirements.

Part 2: Alternative and additional procedures.

BS EN 1364 Fire resistance tests for non-loadbearing elements.

Part 1: Walls.

Part 2: Ceiling (Non Load Bearing).

Part 4: Curtain Walling.

BS EN 1365

Part 2: Floors and roofs.

BS EN 1634 Fire resistance tests for door and shutter assemblies.

Part 1: Fire doors and shutters.

## Relevant Impact Safety Test Standards

BS 6206 specification for impact performance requirements for flat safety glass & safety plastics for use in buildings.

BS EN 12600 : 2002 Glass in building – pendulum test. Impact test method and classification for flat glass.



Pilkington **Pyrodur™** Plus is the ideal choice for internal use in hospitals, schools, offices and many other public places.



Pilkington **Pyrostop**™  
Kensington Village, London.

## Integrity and Insulation

### Pilkington **Pyrostop**™

The clear alternative to a solid fire wall, this combines a high level of fire performance with impact safety to offer flexibility in a wide variety of applications.

By using special interlayers, these combine integrity and heat insulation, to limit the transmission of conductive and radiant heat with a clear glass. In case of fire the interlayer reacts to heat and foams to provide an opaque barrier. Pilkington **Pyrostop**™ products are one of the first fire-resistant glass products to meet the current European fire and impact test standards.

### Description

- A clear, multi-laminated fire-resistant glass, which both retains its integrity and fully insulates against heat transfer from a fire.
- Thicknesses vary from 15 to 62mm, depending on the level of fire protection.
- Thicker products in the range based uniquely on Pilkington **Optiwhite**™ high light transmission glass to give good transparency.
- Clarity, a choice of thicknesses and options for decorative effects, e.g. sandblasting, make it ideal for a wide range of applications.
- Forms an opaque barrier against flames, hot gases and heat during a fire.

### Performance

- Restricts the spread of flames, hot gases and heat.
- Offers up to 120 minutes integrity and insulation in suitable glazing systems.
- Provides impact safety up to Class A to BS 6206 and Class 1(B)1 to BS EN 12600 : 2002.
- Pilkington **Pyrostop**™ also has excellent noise reduction properties.
- Versions are available for up to 180 minutes performance and for particularly intense fire situations when exposed to the hydrocarbon test curve, such as in oil field installations.

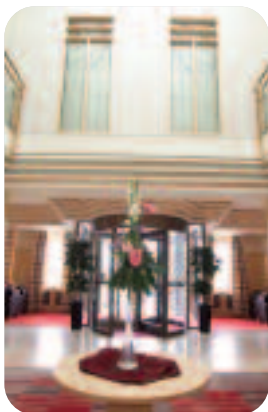

Pilkington **Pyrostop**™  
Radisson Hotel, Sligo.

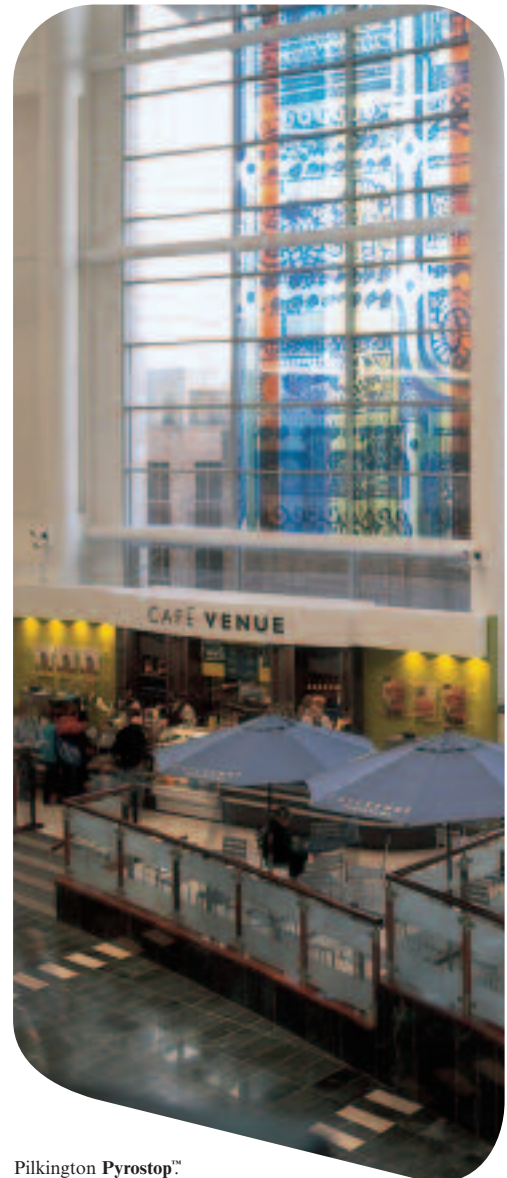

Pilkington **Pyrostop**™  
Midsummer Boulevard, Milton Keynes.

### Benefits

- Readily available direct from Pilkington or through a national network of independent stockists.
- Suitable for a wide range of frame designs and systems.
- Tested and approved with most reputable fire-resistant glazing gaskets and sealants.
- Independently approved for use in a wide range of applications under the Certifire Scheme reference CF328.
- May be used in conjunction with sprinkler systems.

# Integrity with some Insulation

Pilkington **Pyrodur™** and Pilkington **Pyrodur™** Plus.

By using fewer of the same special interlayers in Pilkington **Pyrostop™**, these combine integrity with some heat insulation, to limit the transmission of conductive and radiant heat with a clear glass. In case of fire the interlayer reacts to heat and foams to provide an opaque barrier. In exactly the same way as Pilkington **Pyrostop™**, Pilkington **Pyrodur™** products are some of the first fire-resistant glass products to meet the current European fire and impact test standards.

## Description

- A clear, multi-laminated fire-resistant glass.
- Clarity and options for decorative effects, e.g. sandblasting, make it ideal for use in doors and screens.
- Forms an opaque barrier against flames and hot gases, moreover it reduces the transfer of radiant heat significantly.
- An integrity only glass with some insulation performance and impact safety.

## Performance – Pilkington **Pyrodur™**

- Restricts the spread of flames and hot gases, moreover it partially reduces the transfer of radiant heat.
- Nominal 10mm (types 30-201 and 60-10) and 13mm (type 60-20) thicknesses, containing two interlayers and one safety impact protection interlayer.
- Offers up to 60 minutes integrity, together with some heat insulation in suitable glazing systems.
- Provides impact safety up to Class B to BS 6206 and Class 1(B)1 to BS EN 12600 : 2002.
- Suitable for both internal and external applications.

## Performance – Pilkington **Pyrodur™** Plus

- Restricts the spread of flames and hot gases, and reduces the transfer of radiant heat.
- Ideal for internal glazing applications with its nominal 7mm thickness, containing one purpose designed interlayer.

- Offers 30 minutes integrity, with heat insulation exceeding 15 minutes and exceptionally low levels of transmitted radiant heat.
- Provides impact safety up to Class B to BS 6206 : 1981 and Class 2 (B) 2 to BS EN 12600 : 2002 (ref TNO TPD), i.e. it behaves as a laminated glass under impact.
- The narrow 7mm thickness makes it a natural choice for internal glazing applications such as fire doors and partitions.



Pilkington **Pyrodur™** Plus.  
Harbour Hotel, Co. Galway.

## Benefits

- Readily available direct from Pilkington or through a national network of independent specialist stockists.
- Tested and approved with a wide range of fire-resistant glazing gaskets and sealants.
- Independently approved for use in a wide range of applications under the Certifire Scheme reference CF328.
- Whilst there are no requirements in UK standards or regulations for insulation less than 30 minutes, the full insulation for a shorter period achieved by Pilkington **Pyrodur™** and Pilkington **Pyrodur™** Plus could prove invaluable during evacuation of a building.

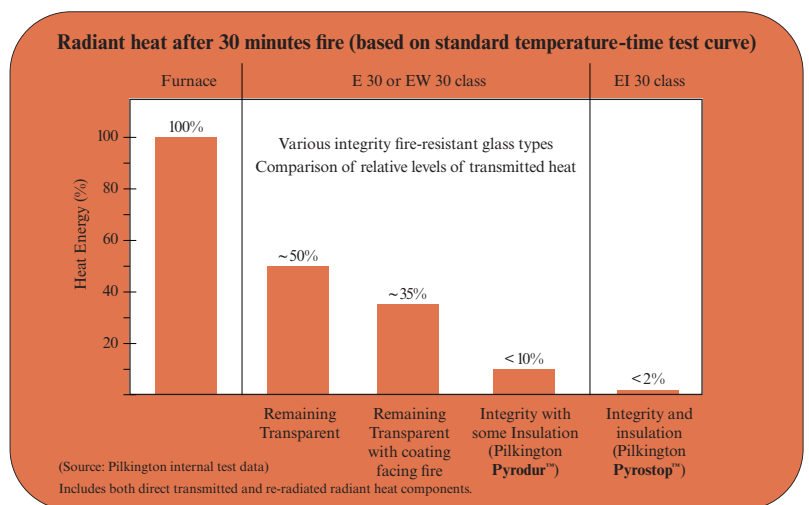

Controlling radiant heat is a significant factor in saving lives as well as an important mechanism influencing the spread of fire. Although radiant heat reduction is not a requirement in UK regulations, comparison of transmitted radiant heat levels does provide a ready means of comparing different integrity glazings.

It should be especially considered for large glazed areas where the levels of radiant heat passing through can be dangerously high.

## Integrity only, or 'non-insulating'



Pilkington **Pyroshield™** Safety.  
St Mary's & St Thomas Church  
of England School, St Helens.

Pilkington **Pyroshield™**  
and Pilkington **Pyroshield™** Safety.

The original fire-resistant glass, and still the most popular, thanks to its long track record in fire testing, exceptional value for money and ease of handling, stocking and glazing.

### Description

- A monolithic, wired glass providing integrity fire protection, even in softwood frames.
- Available in clear or textured versions, for obscuration or privacy respectively.
- An integral wire mesh incorporated within the glass effectively holds the product together in case of thermal shock caused by fire.
- A thicker gauge of wire mesh is used to produce an impact safety version: Pilkington **Pyroshield™** Safety.

### Performance

- Meets European fire test standards.
- Restricts the spread of flames and hot gases.
- Offers up to 120 minutes integrity in specialist steel frames and up to 60 minutes in timber frames when tested to BS 476 Part 22.
- Maintains integrity even when fractured or sprayed with water.
- Safety version provides impact safety to Class C of BS 6206.
- Successfully tested in very large pane sizes, up to 1800mm x 2940mm.
- One of the most extensively used fire-resistant products in the world.

### Benefits

- Readily available and easy to handle, stock and cut.
- Suitable for internal and external applications.
- Tested and approved with a wide range of fire-resistant glazing gaskets and sealants.
- Independently approved for use in a wide range of applications under the Certifire Scheme.
- Internal single glaze is comparable to a normal double glazed unit for sound insulation.

## Choosing the right glass for your application

It is extremely important to make sure you specify and use the right product for the right application.

Our highly experienced specialist sales, technical teams and useful support materials can give you all the help and guidance you need from the outset.

## Pilkington Specifire



The Pilkington Specifire incorporates all the information you need to choose the right product for your application.

By answering a series of questions you are taken to a screen highlighting the product, its properties and performance and details of its fire testing pedigree. The disc also incorporates copies of all Pilkington's fire test summaries and details of compatible sealant materials.

## Contact

For further technical assistance phone our helpline on 01744 692000, e-mail us at [pilkington@respond.uk.com](mailto:pilkington@respond.uk.com) or call any of our specialists around the UK and Ireland.

Anders Glass Limited, Manchester  
0161 736 2487/8

Float Glass Industries Limited, Manchester  
0161 946 8000

Glas-Seal (N.I.) Limited, Co. Down  
028 9756 2932

Nicholls & Clarke Glass Limited, London  
0208 986 6212

T&W Ide Fire Products Limited, London  
0207 790 2333

## Glazing systems

Fire-resistant glass will only perform as intended when it is correctly installed with appropriate glazing materials in a suitable fire-resistant frame. For all fire-resistant glazing, the whole assembly must function as an integral system – that is the glass together with the frame, beads, bead fixings, glazing materials and frame fixings all working together with absolute compatibility.

The most common framing materials are timber or steel. However, other materials such as aluminium, concrete and gypsum board have been used in fire-resistant glazed screens. Examples of typical glazing details are shown in the figures.

For the right choice of framing system and glass, it is important to advise at specification stage whether the application is an internal or external one.

### Steel

- To avoid the more than critical deflection usually associated with steel when it's exposed to fire, we only test our glass in proprietary fire-resistant steel framing systems.
- For full insulation fire resistance, thermal insulation material is usually incorporated into the frame design.
- Glazing materials are usually intumescent or ceramic fibre.
- Using Pilkington **Pyrostop™** or Pilkington **Pyroshield™** steel frames can achieve up to 120 minutes fire resistance.

### Timber

- Can be either hardwood or softwood (over a range of densities).
- For maximum integrity, chamfered beads should be attached with long wooden screws driven at an angle.
- The gap between beads and glass should be filled with an appropriate glazing material, such as an intumescent gasket or non-combustible glazing tape.
- Well designed timber frames can achieve over 60 minutes integrity.

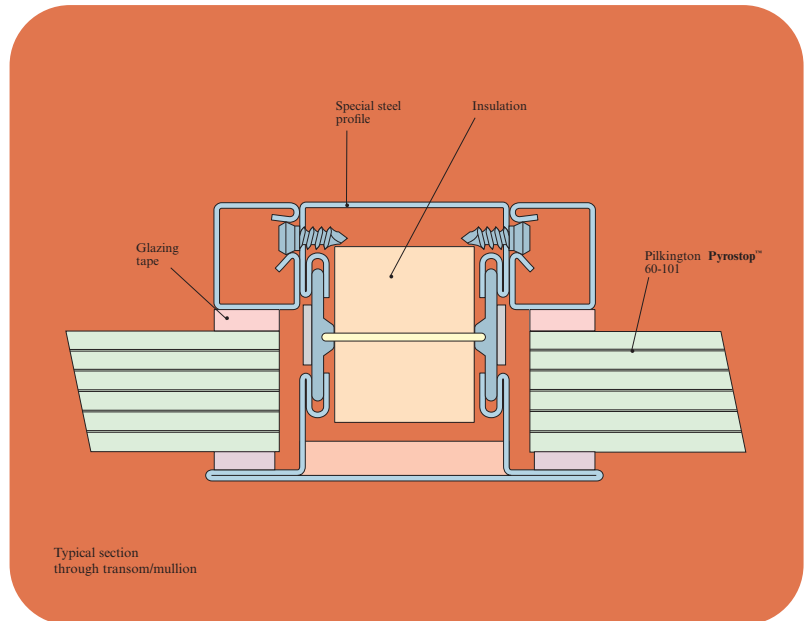

Pilkington **Pyrostop™** in Multi-pane Steel Screen. 60 minutes integrity and 60 minutes insulation. Fire Test Reference: WARRES 113978.

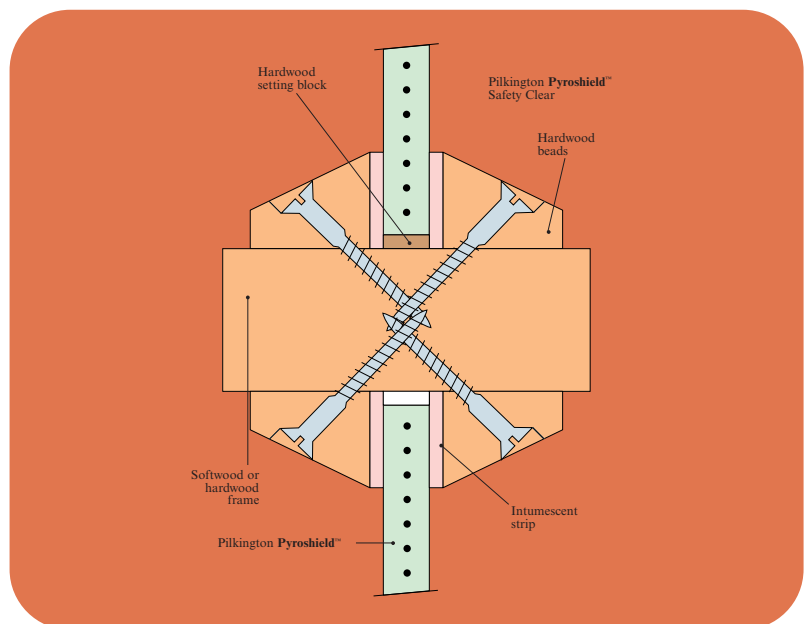

Pilkington **Pyroshield™** Safety Clear in Softwood Timber Screen. 30 minutes integrity. Fire Test Reference: WARRES 70068.

This publication gives a general description of the product and materials. It is the responsibility of the users to ensure that their use is appropriate for any particular application and that such application complies with all relevant local and national legislation, standards, codes of practice and other requirements.

Pilkington plc and its subsidiaries hereby disclaim all liability howsoever arising from any error in or omission from this publication and all consequences of relying on it. Pilkington **Pyrostop**<sup>™</sup>, Pilkington **Pyrodur**<sup>™</sup>, Pilkington **Pyrodur**<sup>™</sup> Plus and Pilkington **Pyroshield**<sup>™</sup> are trade marks of the Pilkington Group.



**PILKINGTON**

**Building Products - UK**

Prescot Road St Helens WA10 3TT United Kingdom

Telephone 01744 692000 Fax 01744 692880

[pilkington@respond.uk.com](mailto:pilkington@respond.uk.com)

[www.pilkington.com](http://www.pilkington.com)



# Fire-Resistant Glass Range

## Technical Information



### Fire Performance Table for Timber Frames

This table provides a quick reference guide only. For further details and specifications please consult Pilkington or a member of our network of independent stockists.

Performance	Wired or Clear	Fire Resistance (mins)		Glass Type	Fire Test Evidence and Recommended Maximum Sizes <sup>a</sup>	
		Integrity	Insulation		Timber Frame <sup>b</sup>	
					Doors	Screens <sup>c</sup>
Integrity and Insulation	Clear	60 <sup>d</sup>	30	15mm Pilkington <b>Pyrostop</b> <sup>™</sup> 30-10 Internal Grade	CF328 <sup>1</sup> Max area 1.11m <sup>2</sup> Max w. 630 or Max h. 1790	CF328 <sup>1</sup> Max area 5.25m <sup>2</sup> Max w. 3000 or Max h. 3000 <sup>e</sup>
		60 <sup>d</sup>	30	18mm Pilkington <b>Pyrostop</b> <sup>™</sup> 30-20 External Grade	CF328 <sup>1</sup> Max area 1.11m <sup>2</sup> Max w. 630 or Max h. 1790	CF328 <sup>1</sup> Max area 5.25m <sup>2</sup> Max w. 3000 or Max h. 3000 <sup>e</sup>
		60 <sup>d</sup>	30	29mm Pilkington <b>Pyrostop</b> <sup>™</sup> 30-15 Internal Grade IGU <sup>f</sup> 32mm Pilkington <b>Pyrostop</b> <sup>™</sup> 30-25 External Grade IGU <sup>f</sup>	–	CF328 <sup>1</sup> Max area 3.43m <sup>2</sup> Max w. 1850 or Max h. 2820
		60	60	23mm Pilkington <b>Pyrostop</b> <sup>™</sup> 60-101 Internal Grade	RF 05035 793 x 1791	CF328 <sup>1</sup> Max area 5.01m <sup>2</sup> Max w. 3000 or Max h. 3000 <sup>e</sup>
		60	60	27mm Pilkington <b>Pyrostop</b> <sup>™</sup> 60-201 External Grade	–	CF328 <sup>1</sup> Max area 5.01m <sup>2</sup> Max w. 3000 or Max h. 3000 <sup>e</sup>
		60	60	37mm Pilkington <b>Pyrostop</b> <sup>™</sup> 60-151 Internal Grade IGU <sup>g</sup> 41mm Pilkington <b>Pyrostop</b> <sup>™</sup> 60-251 External Grade IGU <sup>g</sup>	–	CF328 <sup>1</sup> Max area 3.53m <sup>2</sup> Max w. 1879 or Max h. 2500
		60	60	51mm Pilkington <b>Pyrostop</b> <sup>™</sup> 60-161 S Internal Grade IGU <sup>h</sup>	–	RF04017 Max w. 1220 x Max h. 2470
Integrity with some Insulation	Clear	30	0 <sup>i</sup>	7mm Pilkington <b>Pyrodur</b> <sup>™</sup> Plus 30-104 Internal Grade	CF328 <sup>1</sup> Max area 1.95m <sup>2</sup> Max w. 950 x Max h. 2050	CF328 <sup>1</sup> Max area 3.67m <sup>2</sup> Max w. 2050 or Max h. 2050 <sup>e</sup>
		30	0 <sup>i</sup>	10mm Pilkington <b>Pyrodur</b> <sup>™</sup> 30-201 External Grade	CF328 <sup>1</sup> Max area 2.16m <sup>2</sup> Max w. 965 or Max h. 2240	CF328 <sup>1</sup> Max area 4.47m <sup>2</sup> Max w. 2114 or Max h. 2523 <sup>e</sup>
		30	0	24mm Pilkington <b>Pyrodur</b> <sup>™</sup> 30-251 External Grade IGU <sup>l</sup>	–	CF328 <sup>1</sup> Max area 4.47m <sup>2</sup> Max w. 2114 or Max h. 2523
		60	0 <sup>i</sup>	10mm Pilkington <b>Pyrodur</b> <sup>™</sup> 60-10 Internal Grade	RF 05036 792 x 1790	RF 05036 850 x 1965
		60	0 <sup>i</sup>	13mm Pilkington <b>Pyrodur</b> <sup>™</sup> 60-20 External Grade	CF328 <sup>1</sup> Max area 1.06m <sup>2</sup> Max w. 647 or Max h. 2017	C82442 1400 x 2000
Integrity only	Wired	30	0	6mm Pilkington <b>Pyroshield</b> <sup>™</sup> Clear	C81232 - less than 0.5m <sup>2</sup> small dim < 250mm	C81232 1170 x 3000 <sup>k</sup>
		30	0	7mm Pilkington <b>Pyroshield</b> <sup>™</sup> Texture	C81232 - less than 0.5m <sup>2</sup> small dim < 250mm	C81232 1170 x 3000 <sup>k</sup>
		30	0	6mm Pilkington <b>Pyroshield</b> <sup>™</sup> Safety Clear	C81232 900 x 3000	C81232 1400 x 3000 <sup>k</sup>
		30	0	7mm Pilkington <b>Pyroshield</b> <sup>™</sup> Safety Texture	C81232 900 x 3000	C81232 1170 x 3000 <sup>k</sup>
		60	0	6mm Pilkington <b>Pyroshield</b> <sup>™</sup> Clear	C81232 - less than 0.5m <sup>2</sup> small dim < 250mm	C81232 1170 x 3000 <sup>k</sup>
		60	0	7mm Pilkington <b>Pyroshield</b> <sup>™</sup> Texture	C81232 - less than 0.5m <sup>2</sup> small dim < 250mm	C81232 1170 x 3000 <sup>k</sup>
		60	0	6mm Pilkington <b>Pyroshield</b> <sup>™</sup> Safety Clear	C81232 900 x 3000	C81232 1400 x 3000 <sup>k</sup>
		60	0	7mm Pilkington <b>Pyroshield</b> <sup>™</sup> Safety Texture	C81232 900 x 3000	C81232 1170 x 3000 <sup>k</sup>

a Maximum tested size does not necessarily relate to maximum fire resistance

b Refer to fire test summaries for frame details

c Use Pilkington **Pyroshield**<sup>™</sup> Safety for areas subject to Approved Document N requirements. i.e. low level glazing and Pilkington **Pyroshield**<sup>™</sup> information from WFR C81232

d Only achieved in this specific test

e Maximum recommended sizes are close to maximum available stock sizes so should only be specified following consultation with Pilkington Technical Helpline

f 15mm (30-15) or 18mm (30-25) Pilkington **Pyrostop**<sup>™</sup> / 8mm steel spacer / 6mm non-fire rated glass

g 23mm (60-151) or 27mm (60-251) Pilkington **Pyrostop**<sup>™</sup> / 8mm steel spacer / 6mm non-fire rated glass

h 23mm Pilkington **Pyrostop**<sup>™</sup> / 22mm spacer with integral blind / 6mm non-fire rated glass

i There is no requirement in UK standards or regulations for insulation of less than 30 minutes, however these products achieve full insulation for a short period of time and remain opaque throughout the test

j 10mm Pilkington **Pyrodur**<sup>™</sup> / 8mm steel spacer / 6mm non-fire rated glass

k Hardwood

l Refer to Pilkington Technical Helpline when considering the use of evidence based on Certifire Approvals

Certifire certification can be viewed at [www.wfrc.co.uk/testing.htm](http://www.wfrc.co.uk/testing.htm)

NOTE: The Pilkington fire-resistant glass range holds more than 100 official test approvals, including single glazed and IGU applications. Details can be provided on request. Summary of Physical Data can be found on page 3. Please refer to our published fire test summaries for individual details.

# Fire Performance Table for Steel Frames

Performance	Wired or Clear	Fire Resistance (mins)		Glass Type	Fire Tested Evidence and Recommended Maximum Sizes <sup>a,b</sup>	
		Integrity	Insulation		Steel Frame <sup>c</sup>	
					Doors	Screens <sup>d</sup>
Integrity and Insulation	Clear	30	30	15mm Pilkington <b>Pyrostop</b> <sup>™</sup> 30-10 Internal Grade	–	CF328 <sup>p</sup> Max area 5.25m <sup>2</sup> Max w. 3000 or Max h. 3000 <sup>b</sup>
		60 <sup>e</sup>	30	15mm Pilkington <b>Pyrostop</b> <sup>™</sup> 30-10 Internal Grade	–	CF328 <sup>p</sup> Max area 3.43m <sup>2</sup> Max w. 3000 or Max h. 3000
		60 <sup>f</sup>	30	18mm Pilkington <b>Pyrostop</b> <sup>™</sup> 30-20 External Grade	–	CF328 <sup>p</sup> Max area 3.43m <sup>2</sup> Max w. 1862 or Max h. 2860
		60	30	29mm Pilkington <b>Pyrostop</b> <sup>™</sup> 30-15 Internal Grade IGU <sup>f</sup> 32mm Pilkington <b>Pyrostop</b> <sup>™</sup> 30-25 External Grade IGU <sup>f</sup>	–	CF328 <sup>p</sup> Max area 3.43m <sup>2</sup> Max w. 1850 or Max h. 2820
		60	60	23mm Pilkington <b>Pyrostop</b> <sup>™</sup> 60-10I Internal Grade	CF328 <sup>p</sup> Max area 1.79m <sup>2</sup> Max w. 1338 or Max h. 2280	Warres 113978 1495 x 2895
		60	60	51mm Pilkington <b>Pyrostop</b> <sup>™</sup> 60-16I S Internal Grade IGU <sup>g</sup>	–	Warres 110738 Max w. 1140 x Max h. 2390
		60	60	27mm Pilkington <b>Pyrostop</b> <sup>™</sup> 60-20I External Grade	CF328 <sup>p</sup> Max area 1.79m <sup>2</sup> Max w. 1338 or Max h. 2280	CF328 <sup>p</sup> Max area 4.13m <sup>2</sup> Max w. 2031 or Max h. 2500
		90	90	46mm Pilkington <b>Pyrostop</b> <sup>™</sup> 90-100 Internal Grade IGU <sup>h</sup>	–	CF328 <sup>p</sup> Max area 2.8m <sup>2</sup> Max w. 1400 x Max h. 2000
		90	90	50mm Pilkington <b>Pyrostop</b> <sup>™</sup> 90-100 Internal Grade IGU <sup>i</sup>	–	Warres 57296 755 x 988
		90	90	53mm Pilkington <b>Pyrostop</b> <sup>™</sup> 90-200 External Grade IGU <sup>j</sup>	–	CF328 <sup>p</sup> Max area 2.8m <sup>2</sup> Max w.1400 x Max h.2000
		120	120	52mm Pilkington <b>Pyrostop</b> <sup>™</sup> 120-104 Internal Grade IGU <sup>k</sup>	–	CF328 <sup>p</sup> Max area 3.57m <sup>2</sup> Max w. 1889 or Max h. 2520
		120	120	58mm Pilkington <b>Pyrostop</b> <sup>™</sup> 120-104 Internal Grade IGU <sup>l</sup>	–	CF328 <sup>p</sup> Max area 3.57m <sup>2</sup> Max w. 1889 or Max h. 2520
		120	120	62mm Pilkington <b>Pyrostop</b> <sup>™</sup> 120-20I External Grade IGU <sup>m</sup>	–	CF328 <sup>p</sup> Max area 3.57m <sup>2</sup> Max w. 1889 or Max h. 2520
		Integrity with some Insulation	Clear	30	0 <sup>n</sup>	7mm Pilkington <b>Pyrodur</b> <sup>™</sup> Plus 30-104 Internal Grade
30	0 <sup>n</sup>			10mm Pilkington <b>Pyrodur</b> <sup>™</sup> 30-20I External Grade	CF328 <sup>p</sup> Max area 2.58m <sup>2</sup> Max w. 1069 or Max h. 2415	CF328 <sup>p</sup> Max area 6.0m <sup>2</sup> Max w. 3000 or Max h. 3000
30	0 <sup>n</sup>			24mm Pilkington <b>Pyrodur</b> <sup>™</sup> 30-25I External Grade IGU <sup>n</sup>	–	CF328 <sup>p</sup> Max area 3.75m <sup>2</sup> Max w. 1500 or Max h. 2500
60	0 <sup>n</sup>			10mm Pilkington <b>Pyrodur</b> <sup>™</sup> 30-20I External Grade	–	Warres 112856 1430 x 2905
30	0 <sup>n</sup>			13mm Pilkington <b>Pyrodur</b> <sup>™</sup> 60-20 External Grade	–	CF328 <sup>p</sup> Max area 3.67m <sup>2</sup> Max w. 3000 or Max h. 3000
60	0 <sup>n</sup>			13mm Pilkington <b>Pyrodur</b> <sup>™</sup> 60-20 External Grade	–	CF328 <sup>p</sup> Max area 2.85m <sup>2</sup> Max w. 3000 or Max h. 3000
Integrity only	Wired	30	0	6mm Pilkington <b>Pyroshield</b> <sup>™</sup> Clear	C81232 - less than 0.5m <sup>2</sup> small dim < 250mm	C81232 1760 x 3000
		30	0	7mm Pilkington <b>Pyroshield</b> <sup>™</sup> Texture	C81232 - less than 0.5m <sup>2</sup> small dim < 250mm	C81232 1760 x 3000
		30	0	6mm Pilkington <b>Pyroshield</b> <sup>™</sup> Safety Clear	C81232 900 x 3000	C81232 1760 x 3000
		30	0	7mm Pilkington <b>Pyroshield</b> <sup>™</sup> Safety Texture	C81232 900 x 3000	C81232 1760 x 3000
		60	0	6mm Pilkington <b>Pyroshield</b> <sup>™</sup> Clear	–	C81232 1170 x 3000
		60	0	7mm Pilkington <b>Pyroshield</b> <sup>™</sup> Texture	–	C81232 1170 x 3000
		60	0	6mm Pilkington <b>Pyroshield</b> <sup>™</sup> Safety Clear	C81232 900 x 3000	C81232 1170 x 3000
		60	0	7mm Pilkington <b>Pyroshield</b> <sup>™</sup> Safety Texture	C81232 900 x 3000	C81232 1170 x 3000
		90	0	6mm Pilkington <b>Pyroshield</b> <sup>™</sup> Safety Clear	–	C81232 1000 x 3000
		90	0	7mm Pilkington <b>Pyroshield</b> <sup>™</sup> Safety Texture	–	C81232 1000 x 2400
		120	0	6mm Pilkington <b>Pyroshield</b> <sup>™</sup> Safety Clear	–	C81232 930 x 3000
		120	0	7mm Pilkington <b>Pyroshield</b> <sup>™</sup> Safety Texture	–	C81232 1000 x 2100

a Maximum tested size does not necessarily relate to maximum fire resistance

b Maximum recommended sizes are close to maximum available stock sizes so should only be specified following consultation with Pilkington Technical Helpline

c Refer to fire test summaries for frame details

d Use Pilkington **Pyroshield**<sup>™</sup> Safety for areas subject to Approved Document N requirements, i.e. low level glazing and Pilkington **Pyroshield**<sup>™</sup> information from WFRC C81232

e Only achieved in this specific test

f 15mm (30-15) or 18mm (30-25) Pilkington **Pyrostop**<sup>™</sup> / 8mm steel spacer / 6mm non-fire rated glass

g 23mm Pilkington **Pyrostop**<sup>™</sup> / 22mm spacer with integral blind / 6mm non-fire rated glass

h 15mm Pilkington **Pyrostop**<sup>™</sup> / 8mm steel spacer / 23mm Pilkington **Pyrostop**<sup>™</sup>

i 15mm Pilkington **Pyrostop**<sup>™</sup> / 12mm steel spacer / 23mm Pilkington **Pyrostop**<sup>™</sup>

j 18mm Pilkington **Pyrostop**<sup>™</sup> / 12mm steel spacer / 23mm Pilkington **Pyrostop**<sup>™</sup>

k 23mm Pilkington **Pyrostop**<sup>™</sup> / 6mm steel spacer / 23mm Pilkington **Pyrostop**<sup>™</sup>

l 23mm Pilkington **Pyrostop**<sup>™</sup> / 12mm steel spacer / 23mm Pilkington **Pyrostop**<sup>™</sup>

m 27mm Pilkington **Pyrostop**<sup>™</sup> / 12mm steel spacer / 23mm Pilkington **Pyrostop**<sup>™</sup>

n There is no requirement in UK standards or regulations for insulation of less than 30 minutes, however these products achieve full insulation for a short period of time and remain opaque throughout the test

o 10mm Pilkington **Pyrodur**<sup>™</sup> / 8mm steel spacer / 6mm non-fire rated glass

p Refer to Pilkington Technical Helpline when considering the use of evidence based on Certifire Approvals

NOTE: The Pilkington fire-resistant glass range holds more than 100 official test approvals, including single glazed and IGU applications. Details can be provided on request. Summary of Physical Data can be found on page 3. Please refer to our published fire test summaries for individual details.

# Physical Data

Glass Type	Product Code	Fire resistance Integrity Insulation	Nominal Glass Thickness approx - mm	Light Transmission	Weight approx. kg/m <sup>2</sup>	Glass Thickness Tolerance approx. mm	Sound <sup>b</sup> reduction approx - dB	BS 6206 Impact <sup>c</sup>
Pilkington <b>Pyrostop</b> <sup>™</sup>	30-10	30	30	15	0.85	35.0	±1.0	38 B
Pilkington <b>Pyrostop</b> <sup>™ d</sup>	30-15	30	30	29	0.76	51.0	±2.0	38 B
Pilkington <b>Pyrostop</b> <sup>™</sup>	30-20	30	30	18	0.84	42.0	±1.0	38 A
Pilkington <b>Pyrostop</b> <sup>™ c</sup>	30-25	30	30	32	0.75	58.0	±2.0	39 A
Pilkington <b>Pyrostop</b> <sup>™</sup>	60-101	60	60	23	0.88	55.0	±2.0	40 A
Pilkington <b>Pyrostop</b> <sup>™ f</sup>	60-151	60	60	37	0.78	69.0	±3.0	41 A
Pilkington <b>Pyrostop</b> <sup>™ g</sup>	60-161 S	60	60	51	0.78	76.0	±3.0	42 A
Pilkington <b>Pyrostop</b> <sup>™</sup>	60-201	60	60	27	0.86	61.0	±2.0	41 A
Pilkington <b>Pyrostop</b> <sup>™ h</sup>	60-251	60	60	41	0.78	77.0	±2.0	41 A
Pilkington <b>Pyrostop</b> <sup>™ i</sup>	90-100	90	90	46	0.76	89.0	±3.0	42 A
Pilkington <b>Pyrostop</b> <sup>™ j</sup>	90-100	90	90	50	0.76	89.0	±3.0	42 A
Pilkington <b>Pyrostop</b> <sup>™ k</sup>	90-200	90	90	49	0.75	96.0	±3.0	43 A
Pilkington <b>Pyrostop</b> <sup>™ l</sup>	90-200	90	90	53	0.75	96.0	±3.0	43 A
Pilkington <b>Pyrostop</b> <sup>™ m</sup>	120-104	120	120	52	0.78	106.0	±3.0	42 A
Pilkington <b>Pyrostop</b> <sup>™ n</sup>	120-104	120	120	58	0.78	106.0	±3.0	43 A
Pilkington <b>Pyrostop</b> <sup>™ o</sup>	120-201	120	120	62	0.76	116.0	±3.0	44 A
Pilkington <b>Pyrodur</b> <sup>™</sup> Plus	30-104	30	0	7	0.88	17.0	±1.0	35 B
Pilkington <b>Pyrodur</b> <sup>™</sup>	30-201	30	0	10	0.88	24.0	±1.0	36 B
Pilkington <b>Pyrodur</b> <sup>™ p</sup>	30-251	30	0	24	0.78	40.0	±2.0	38 B
Pilkington <b>Pyrodur</b> <sup>™</sup>	60-10	60	0	10	0.88	24.0	±1.0	35 C
Pilkington <b>Pyrodur</b> <sup>™</sup>	60-20	60	0	13	0.86	31.0	±1.0	38 B
Pilkington <b>Pyroshield</b> <sup>™</sup> Clear		30	0	6	0.80	16.6	-0,+1.4	32 N/A
Pilkington <b>Pyroshield</b> <sup>™</sup> Texture		30	0	7	0.79	16.7	±0.7	32 N/A
Pilkington <b>Pyroshield</b> <sup>™</sup> Safety Clear		30	0	6	0.77	16.6	-0,+1.4	32 C
Pilkington <b>Pyroshield</b> <sup>™</sup> Safety Texture		30	0	7	0.76	16.7	±0.7	32 C

a With reference to the relevant product standard

b R<sub>w</sub> index (weight sound reduction) corrected for the human ear based on internal measurements

c BS 6206 classifies individual panes of glass only

d 15mm Pilkington **Pyrostop**<sup>™</sup> / 8mm steel spacer / 6mm non-fire rated glass

e 18mm Pilkington **Pyrostop**<sup>™</sup> / 8mm steel spacer / 6mm non-fire rated glass

f 23mm Pilkington **Pyrostop**<sup>™</sup> / 8mm steel spacer / 6mm non-fire rated glass

g 23mm Pilkington **Pyrostop**<sup>™</sup> / 22mm spacer with integral blind/ 6mm non-fire rated glass

h 27mm Pilkington **Pyrostop**<sup>™</sup> / 8mm steel spacer / 6mm non-fire rated glass

i 15mm Pilkington **Pyrostop**<sup>™</sup> / 8mm steel spacer / 23mm Pilkington **Pyrostop**<sup>™</sup>

j 15mm Pilkington **Pyrostop**<sup>™</sup> / 12mm steel spacer / 23mm Pilkington **Pyrostop**<sup>™</sup>

k 18mm Pilkington **Pyrostop**<sup>™</sup> / 8mm steel spacer / 23mm Pilkington **Pyrostop**<sup>™</sup>

l 18mm Pilkington **Pyrostop**<sup>™</sup> / 12mm steel spacer / 23mm Pilkington **Pyrostop**<sup>™</sup>

m 23mm Pilkington **Pyrostop**<sup>™</sup> / 6mm steel spacer / 23mm Pilkington **Pyrostop**<sup>™</sup>

n 23mm Pilkington **Pyrostop**<sup>™</sup> / 12mm steel spacer / 23mm Pilkington **Pyrostop**<sup>™</sup>

o 27mm Pilkington **Pyrostop**<sup>™</sup> / 12mm steel spacer / 23mm Pilkington **Pyrostop**<sup>™</sup>

p 10mm Pilkington **Pyrodur**<sup>™</sup> / 8mm steel spacer / 6mm non-fire rated glass

**Thermal Safety** – The possibility of excessive thermal stress being developed in the glass due to solar radiation should be considered at all stages of design and construction. It is recommended that a thermal safety check is performed for all sloping installations or when used in insulating glass units or secondary glazing.

**Handling & Storage** – Glass should be stored in dry conditions and out of direct sunlight, stacked upright and fully supported in a manner which prevents the glass from sagging. It should be stood on edge on strips of wood, felt or other relatively soft material. Special care should be taken to protect the glass, especially the edges and the edge protection tape, from impact damage (knocks, abrasions and excessive local pressure). Upon receipt and before glazing, each glass should be checked for damage. Damaged glass should not be glazed. Water must not be allowed to reach the edges of stacked glass as it can be drawn between the plates by capillary action and cause damage which may affect fire performance. The glass must be protected from site contamination such as welding, cementitious, plaster products or adhesives.

Glazing and handling details are available on request.

Insulating glass units incorporating Pilkington fire-resistant glass have been successfully tested and combined with low-E glass help in meeting the requirements of Part L (England & Wales) and Part J (Scotland). Detailed glazing information can be found in our published fire test summaries. We recommend that glazing is carried out by a FIRAS accredited installer.

**Further details** – For technical advice, or to receive a copy of our general CD-ROM or the Pilkington Specifire Selection CD-ROM including all performance details, please call **01744 692000**.

This publication gives a general description of the product and materials. It is the responsibility of the users to ensure that their use is appropriate for any particular application and that such application complies with all relevant local and national legislation, standards, codes of practice and other requirements.

Pilkington plc and its subsidiaries hereby disclaim all liability howsoever arising from any error in or omission from this publication and all consequences of relying on it. Pilkington **Pyrostop**<sup>™</sup>, Pilkington **Pyrodur**<sup>™</sup>, Pilkington **Pyrodur**<sup>™</sup> Plus and Pilkington **Pyroshield**<sup>™</sup> are trade marks of the Pilkington Group.



**PILKINGTON**

**Pilkington Building Products - UK**  
Prescot Road St Helens WA10 3TT United Kingdom  
Telephone 01744 692000 Fax 01744 692880  
pilkington@respond.uk.com  
[www.pilkington.com](http://www.pilkington.com)

