





Edgelit Exit Sign IP30 Class 1 CE Surface Wall 250SM

	230V	250SMLA 250SMLE
	230V	250SMDA
	MM3	250SMLM
	AutoTest	250SMYL
	MM3	250SMDL



1 SURFACE WALL MOUNTED

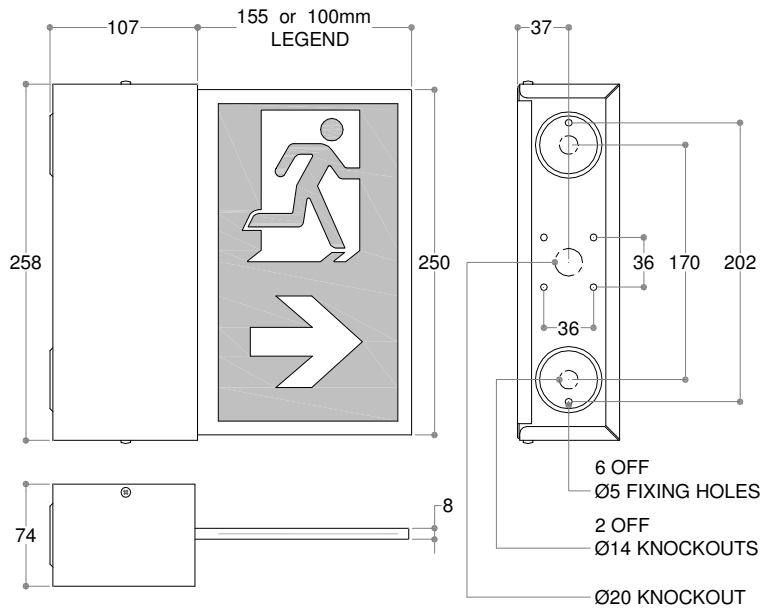
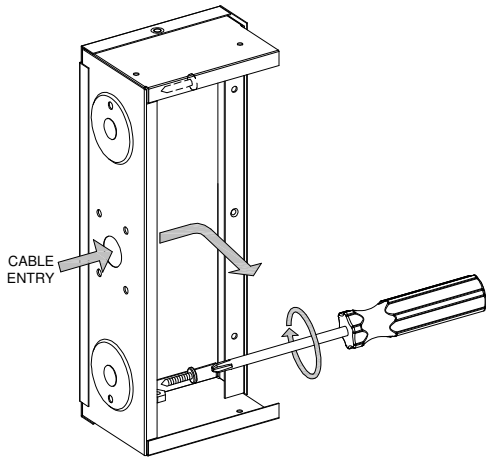

2

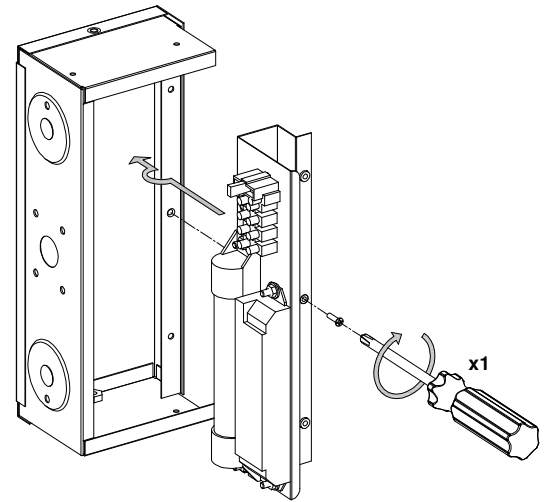

3

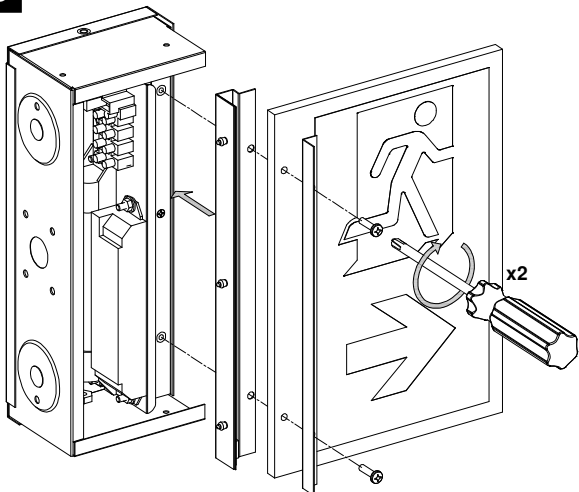

4

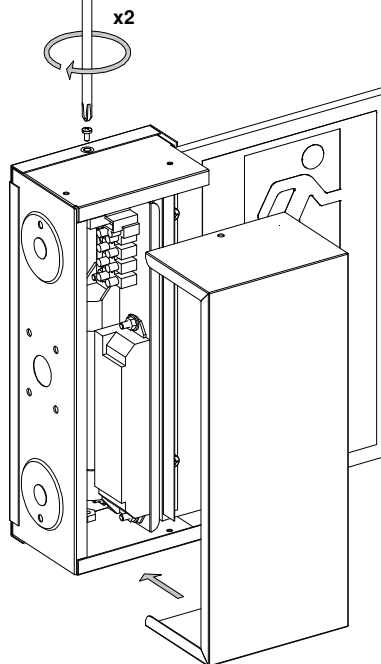

Connections - Connexions - Conexiones



	MM3	MM3
	AutoTest	MM3

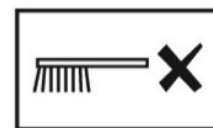
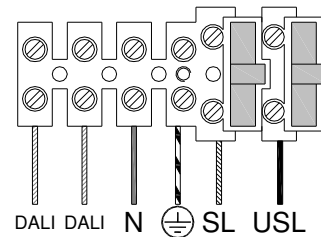
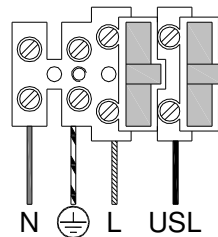
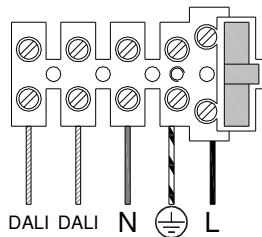
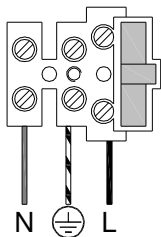

<p>Operation and Maintenance The 250SM uses plastic components in its construction and when installed in environments containing chemicals, degradation may occur. Please contact our Technical Department for advice.</p> <p>Modifications Philip Payne products should not be modified. Any modification may render the product unsafe and will invalidate any Safety/Approval marks. Philip Payne will not accept any responsibility for any modified products or for any damage caused as a result of their modification.</p>	<p>Fonctionnement et Maintenance Des composants en plastique ont été intégrés dans la construction du 250SM, et une certaine détérioration peut survenir lorsqu'il est installé dans des environnements contenant des produits chimiques. Veuillez contacter notre Département Technique pour obtenir de plus amples informations.</p> <p>Modifications Les produits Philip Payne ne doivent pas être modifiés. Toute modification peut compromettre la sécurité du produit et annuler les marques de sécurité / homologation. Philip Payne refusera toute responsabilité pour des produits modifiés ou pour tout dommage entraîné par une modification.</p>	<p>Betrieb und Wartung 250SM-Produkte enthalten Kunststoffteile; bei einer Installation in Umgebungen, die Chemikalien enthalten, ist ein Qualitätsverlust nicht auszuschließen. Unsere Technische Abteilung berät Sie gerne.</p> <p>Änderungen Philip Payne-Produkte sollten nicht geändert werden. Jegliche Änderungen können die Produktsicherheit beeinträchtigen und machen Sicherheits-/Genehmigungskennzeichnungen ungültig. Philip Payne übernimmt keine Verantwortung für modifizierte Produkte bzw. Für Schäden, die durch Produktänderungen verursacht werden.</p>	<p>Funzionamento e manutenzione Il 250SM è stato costruito con componenti di plastica e, se installato in ambienti che contengono sostanze chimiche, si può notare un degradamento. Per ulteriori consigli si prega di contattare il nostro reparto tecnico.</p> <p>Modifiche I prodotti Philip Payne non devono essere modificati, dato che qualsiasi modifica potrebbe rendere il prodotto insicuro e invalidare ogni segno di sicurezza/approvazione. Philip Payne non accetta nessuna responsabilità per prodotti modificati e per danni causati quale risultato delle modifiche apportate agli stessi.</p>
---	--	---	---

Important-Safety
Before carrying out any servicing on this luminaire, ensure that the mains supply is fully isolated. Disconnect luminaire before insulation testing of the installation.

Important-Sécurité
Avant d'effectuer des réparations sur ce luminaire, vérifiez que l'alimentation secteur est coupée. Débranchez le luminaire avant d'effectuer un essai d'isolement de l'installation.

Wichtiger Sicherheitshinweis
Stellen Sie vor Durchführen von Wartungsarbeiten an diesem Beleuchtungskörper sicher, dass die Netzstromversorgung vollständig isoliert ist. Trennen Sie den Beleuchtungskörper von der Stromversorgung, bevor Sie die Isolierung der Anlage testen.

Importante - Sicurezza
Prima di eseguire la manutenzione, assicurarsi chela rete elettrica sia completamente isolata. Scollegare il prodotto prima di eseguire il test d'isolamento dell'installazione.



Philip Payne Ltd
A SUBSIDIARY OF F.W. THORPE PLC
Thornhill Road, Solihull, B91 2HB, England.
Tel: 0121 705 2384
Fax: 0121 711 2469
e-mail: mail@philippayne.co.uk
Website: http://www.philippayne.co.uk
Philip Payne Ltd registered in England No. 1361523



ISO9001
FM55077