

Description:

Single section backlit warning sign c/w side lights.
Semi-secret legend panel (order separately).
Surface wall mounted.

Standards:

- EN60598-1
- EN55015
- EN61547
- EN61000-3-2
- CE marked

Specification:

Weight: 1.5 Kg.
Voltage / Current: Dependent upon gear: See Table 'A'.
Operating Temp: Min 0°C / Max 25°C.
IP Rating: IP30.

Part Numbers Explained:

2618S - A - B

Where:-

'A' designates the lamp & gear type. See Table 'A' for options & codes.

'B' designates the cover finish. See Table 'B' for options & codes.

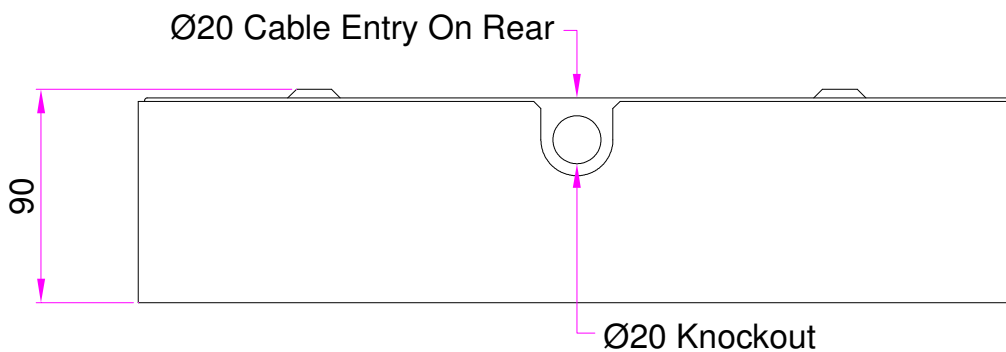
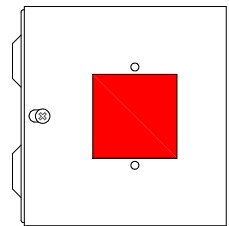
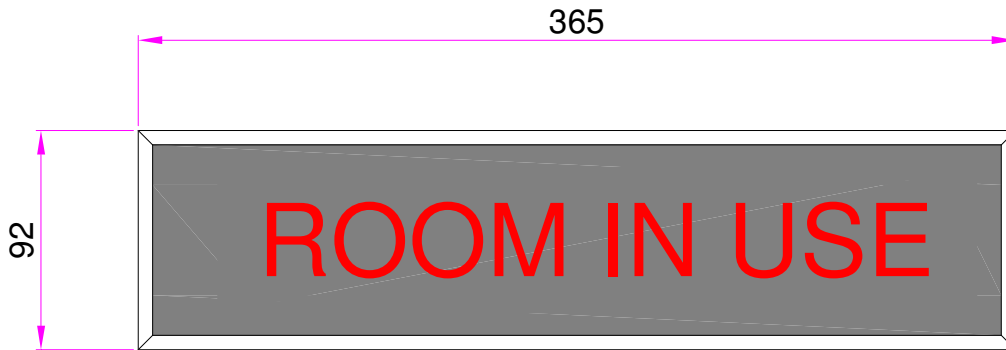

Table 'A': Gear / Operation

'A' Codes	Lamp(s)	Gear	Supply Current*
F	8W T5	220-240V AC 50/60Hz HF Gear	<100mA
IV24	8W T5	24V AC/DC Inverter	<650mA
IV50	8W T5	50V AC/DC Inverter	<200mA
IV110	8W T5	110V AC/DC Inverter	<200mA
L	3W LED light strip	220-240V AC 50/60Hz LED driver	<100mA
LIV	3W LED light strip	12-24V DC LED Driver	<400mA
T	2 x 15W SBC 220-240V AC 50Hz	N/A	<200mA

*Supply current during normal luminaire operation, after inrush current on start up.

Table 'B': Finish Options

'B' Codes	Finish	'B' Codes	Finish
No Suffix	Gloss white as standard.	K	Black RAL9005.
B	Brass. Polished & lacquered.	R	Satin chrome.
C	Polished chrome.	V	Old penny bronze.
D	Brass made antique.	Z	Special finish: customer specification.
G	Grey RAL9006.		

Philip Payne Ltd

A SUBSIDIARY OF F.W. THORPE PLC
Thornhill Road, Lode Lane, Solihull, B91 2HB, England.

Tel: 0121 705 2384

Fax: 0121 711 2469

E-mail: mail@philippayne.co.uk

Website: <http://www.philippayne.co.uk>

Philip Payne Ltd registered in England No. 1361523



ISO 9001
FM55077

2618S_RANGE_7