

# Anchor bolts and studs

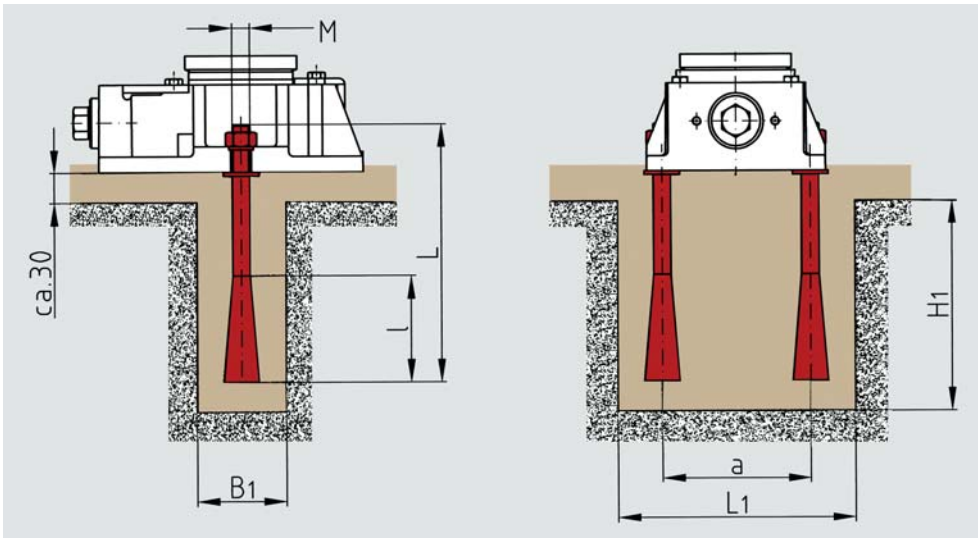

**C** Side anchor bolts for connecting BW-Fixator® to the foundation

RK	M	L	I	a	Foundations			Clamping force max. N
					L1	B1	H1	
I	M12	150	70	90	140	60	140	65 000
II	M12	150	70	100	160	60	140	65 000
III	M16	250	90	130	200	70	240	120 000
IV	M20	300	100	160	240	80	290	190 000
V	M24	350	135	205	305	100	350	275 000

## Other applications

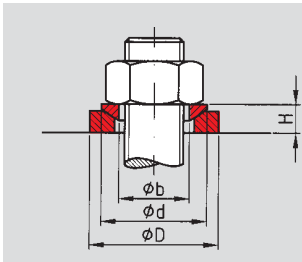

**p** Spherical washer set for non-parallel bearing surfaces

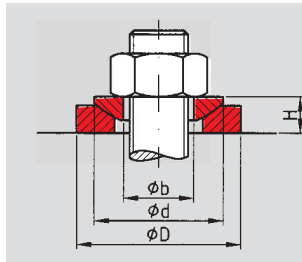

**r** Large spherical washer set for non-parallel bearing surfaces

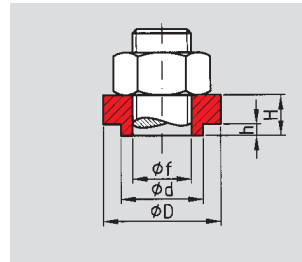

**Z** Foam centering bushing for the concentric location of the anchor bolts in the machine foot holes

RK	∅ D	H	∅ d	∅ b
I (M12)	40	9	30	13
I (M16)	40	9	30	17
II	44	10	36	21
III	56	13	44	25
IV	68	16	56	31
V (M36)	78	20	68	37
V (M42)	100	26	90	44

RK	∅ D	H	∅ d	∅ b
I	44	10	36	17
II	56	13	44	21
III	68	16	56	25
IV	80	16	56	31
V (M36)	100	20	68	37
V (M42)	125	26	90	44

RK	∅ f	∅ D	H	∅ d	h
I	16,2	32	13	22	4
II	20,2	40	14	28	4
III	24,2	44	18	32	5
IV	30,2	54	21	42	5
V (M36)	36,3	60	26	45	6
V (M42)	42,5	70	32	56	6