

# RUSTIC SOFT CLOSE HENDERSON

## Fitting Instructions

### KIT CONTENTS

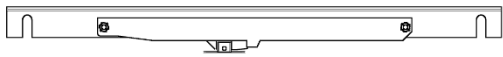

Damper & Plate

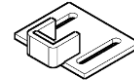

Trigger

**NOTE:** Complete the installation of Rustic Soft Close after you have fitted Rustic 80 as per instructions. These instructions show the Soft Close installed to the left side of the system when facing the track. Rustic Soft Close can be installed onto the left or right hand side of the track – or both for a soft close and open.

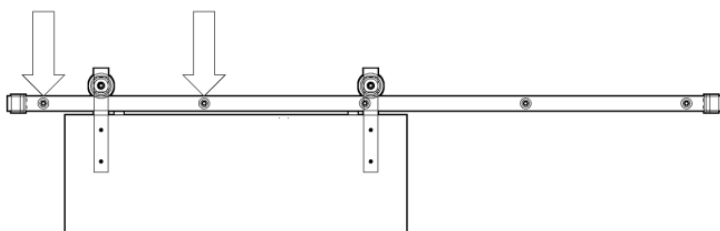

Soft Close goes over end track fixings.  
Disengage anti-jump before removing door.

### STEP BY STEP INSTRUCTIONS

**STEP 1:** Measure X - the distance from the door edge in the closed position to the first hole of the track.

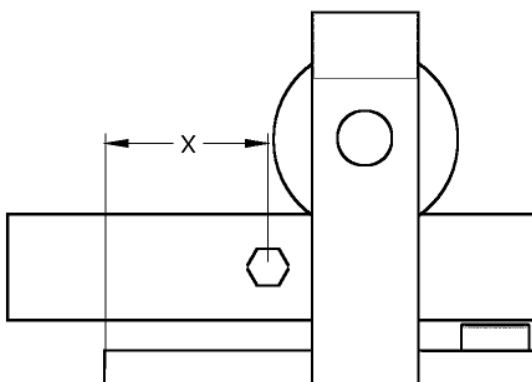

**STEP 2:** Remove the door and door stop from the track.

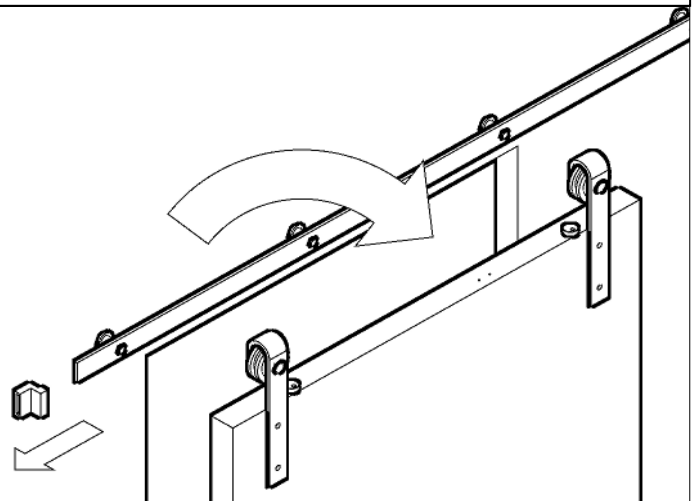

**STEP 3:** Drill pilot holes for the trigger in the position below (X is taken from STEP 1).

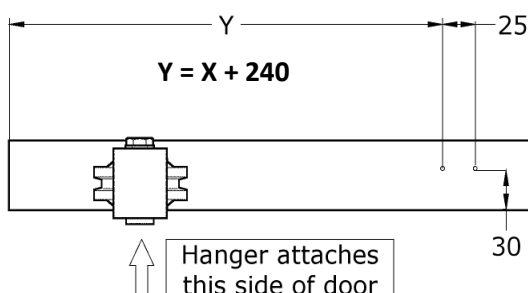

**STEP 4:** Install the Soft Close in correct orientation.  
(Illustrated from the rear, soft close can easily be unscrewed and reversed to get correct orientation).



A: Right



B: Left

**STEP 5:** Loosen end two fixings. Slot Soft Close onto standoffs.

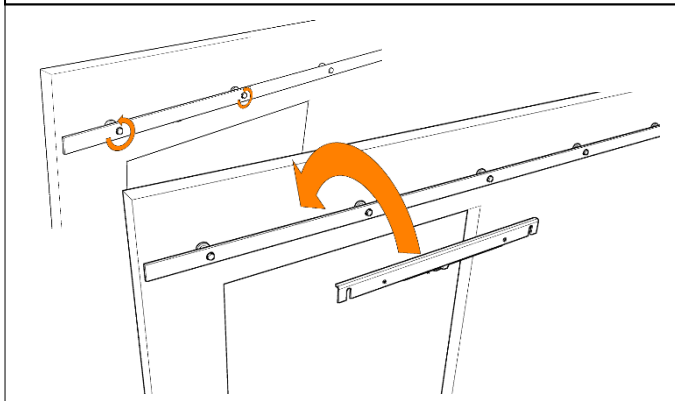

**STEP 6:** The Soft Close sits behind the track. Tighten the two fixings.

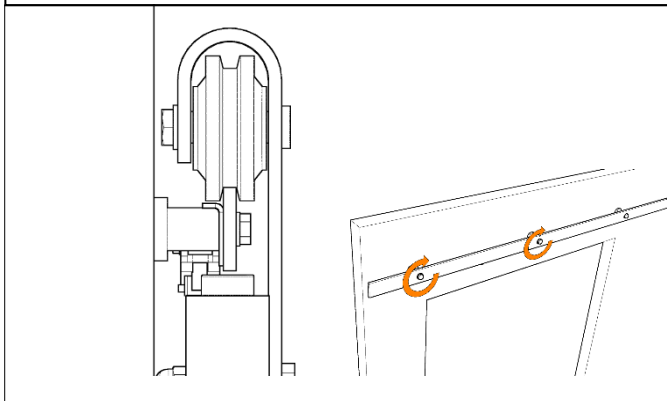

**STEP 7:** Loosely install the trigger on top of the door pushing it as far forward as possible.

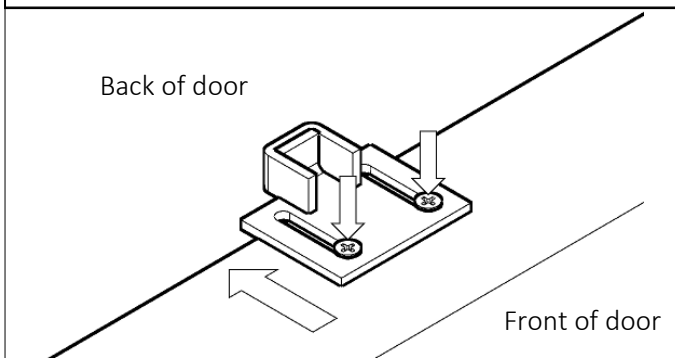

**STEP 8:** Hang the door back on the track, ensuring the floor guide is engaged.

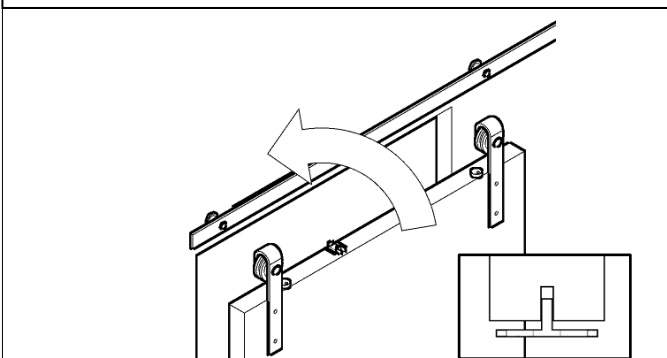

**STEP 9:** Adjust the trigger into the final position and tighten the screws.

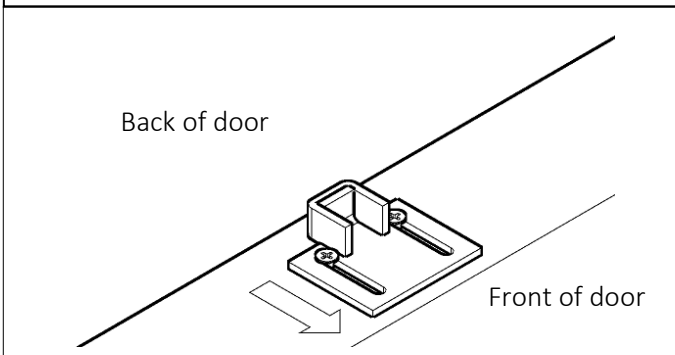

**STEP 10:** Open the jaws of the Soft Close as far as possible

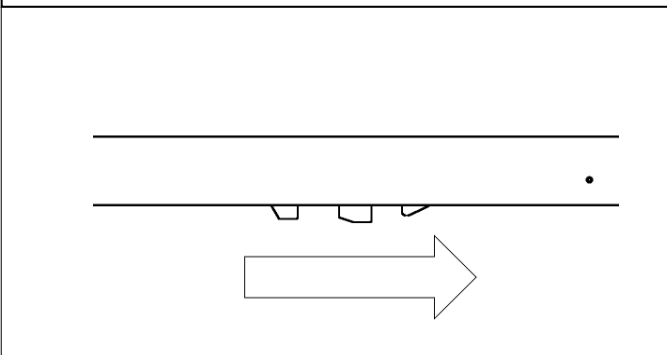

**STEP 11:** Check the engagement of the trigger with the Soft Close jaws. Adjust the trigger height as necessary.

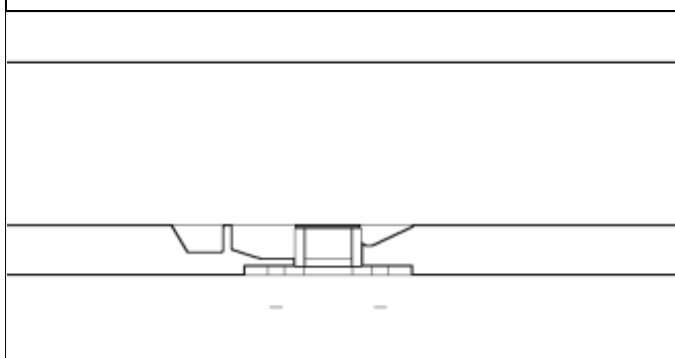

**STEP 12:** Check the anti-jump cams are engaged. Replace the door stop to the ends of the track.

