



origin
DOORS AND WINDOWS

Bi-fold Door (OB-72) Specification File



Contents

Specification Overview	3
Security	7
Optional Extras	8
Door Make-Up	10
Size Limitations	11
Performance and Limitations	12
Master Configurations	22
Technical Drawings	36
Handles	65
Gaskets	70
All Configurations	71
Installation Guide	87
Door Restrictor Installation Guide	105
Door-to-Window Installation Guide	110
Window-to-Jamb Coupler Installation Guide	113
Window-to-Track Coupler Installation Guide	123
Glazing Bar Installation Guide	129
Finger Pull Installation Guide	131
Accreditations	132

Specification Overview

Thermally Broken Aluminium Bi-folding Door

External view of the OB-72 Bi-fold Door (open out)



Internal view of the OB-72 Bi-fold Door (open out)



Profile Specification

Outer Frame Depth	75mm
Sash Depth	59mm
Individual Sash Sightline	72mm
Hingestile Glass to Glass Sightline	154mm
Track Height (not including rebate)	50mm
Weathered Threshold Height	67mm
Non-weathered Threshold Height	50mm
Mobility Threshold Height	20mm

Features

- ▶ Up to a 20-year guarantee**
- ▶ 1-star diamond cylinder as standard
- ▶ The doors are bottom running and incorporate a unique free glide carriage assembly, which uses acetal rollers with sealed stainless steel bearings on an 8mm hardened stainless steel axle
- ▶ Chamfered bead internally and externally
- ▶ Packaged in kit form for easy transportation and installation
- ▶ 8-point locking system and includes chamfered 20mm linear bolts and deep throw 25mm security hooks
- ▶ Thumbturn option available
- ▶ Each door comes with 2-5 solid zinc security hinges depending on height
- ▶ Finger pull handle option to facilitate operation of even numbered door sets from the outside

Options and extras

- ▶ Single, French, Bi-fold and Moving Corner Bi-Fold Doors available
- ▶ Accommodates double and triple glazing, with unit sizes of 28mm or 32mm
- ▶ Weathered, non-weathered or mobility (Class 4A) thresholds are available*
- ▶ Open-in or open-out options
- ▶ Cill options available: 95, 155, 180 and 225mm (see page 53)
- ▶ Available in over 150 RAL colours
- ▶ Gasket colours: black, white, light grey, graphite grey, light oak bronze or chestnut brown
- ▶ Comprehensive handle range, including colour matched options
- ▶ Stainless steel or colour-coded running gear
- ▶ Hinge colours: black, white, stainless steel finish or colour coded
- ▶ Door-to-window coupling available
- ▶ 2500EA and 5000EA trickle vents available
- ▶ Marine finish option
- ▶ Midrail available
- ▶ Traditional glazing bar available
- ▶ 3-star keyed cylinder options

*Mobility threshold is only available on Single and French Doors.

**Guarantee based on location of where the doors will be installed.

Full terms and conditions can be found on the Origin website - origin-global.com/terms-and-conditions.

Specification Overview

The OB-72 is available on 'Your Lead Time, Not Ours' in any of our popular colours.

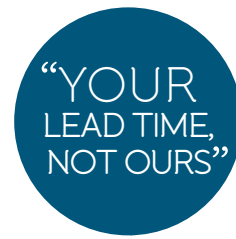

Black Grey (7021M)



Slate Grey (7015M)



Hipca White (9910G and 9910M)



Anthracite Grey (7016M)



Jet Black (9005M)



9910G in/ 7016M out



Light Silver Metallic (9006M)



Dark Silver Metallic (9007M)



Alternatively, dual coloured or any RAL coloured door can be selected on a 3-week lead time

For the full range, visit origin-global.com

Lead Times

Popular colour doors: 24-hours

Special colour doors: 3-weeks

Dual colour doors: 3-weeks

Specification Overview

Even the gasket or Q-lon colour is your choice



The following are also available:



	Door Colour	Recommended Q-Lon Colour
A.	7015M and 9007M	Graphite Grey
B.	7016M	Anthracite Grey
C.	9005M and 7021M	Black
D.	9006M	Light Grey
E.	9910G and 9910M	White

Drainage cap colours

Popular Colour	Gasket Colour	Drainage Cap Colour	X3 Code
9007M (Dark Silver Metallic)	Light Grey	No. 38 Grey	C01349
7021M (Black Grey)	Anthracite Grey	Dark Grey	C01350
9005M (Jet Black)	Black	Black	C01163
7015M (Slate Grey)	Slate Grey	Dark Grey	C01350
9006M (Light Silver Metallic)	Light Grey	Cement Grey	C01352
9910G (Hipca White)	White	White	C01353
7016M (Anthracite Grey)	Anthracite Grey	Dark Grey	C01350

Other gasket and cap colours available

Gasket Colour	Drainage Cap Colour	X3 Code
Light Oak	Oak	C01354
Light Oak	Tan	C01355
Bronze	Black	C01163
Chestnut Brown	Black	C01163

Security

Origin's Multi-Point Lock



All lead doors greater than 1125mm tall contain the Origin multi-point lock

The Origin multi-point lock offers 8-points of locking and is part of the reason our overall door system is PAS 24:2016 certified.* Additionally, it achieves the Secured by Design accreditation.

In the image below, you will see 6-points of locking. We then add a shoot bolt that goes into the top and bottom track, resulting in a total of 8-points of locking

Find out more about SBD on page 135



Locking Cylinders

In addition to our standard 1-star cylinder, you can upgrade to our 3-Star British Kite Mark Cylinder.

3-Star Diamond Cylinder



*PAS 24:2016 is certified when a 3-Star Barrel is selected.

Optional Extras

Trickle Vents

Trickle vents have to meet the minimum air flow rates as defined in the British Building Regulations (see specifics below).

Should it be required, the Origin Door can be specified with discreetly designed trickle vents which are installed through the top track for additional ventilation, ensuring the doors meet and surpass building regulations.



Internal view



External View

Trickle vents on our bi-fold can only be fitted through the top track or through the frame extender.

Thresholds – weathered, non-weathered and mobility

Weathered and non-weathered options are available, so you can pick the right option for to cater for your customer's needs. A mobility threshold option is only available on single doors and French doors.



Door Restrictor

We offer either a 90-degree or 135-degree door restrictor that will limit the door's opening to the respective angle.



Optional Extras

Cills

Choose from our 4 cill options which can also be powder coated to match the doors.



Handles

Choose from a selection of elegant handle styles that have been designed and manufactured with the same care and dedication as every other door component. You can specify from our popular aluminium range or our premium stainless-steel range. Our stainless steel handles, slave handles and D-handles are able to be specified in stainless steel or in a colour coded RAL option.

Premium stainless steel range

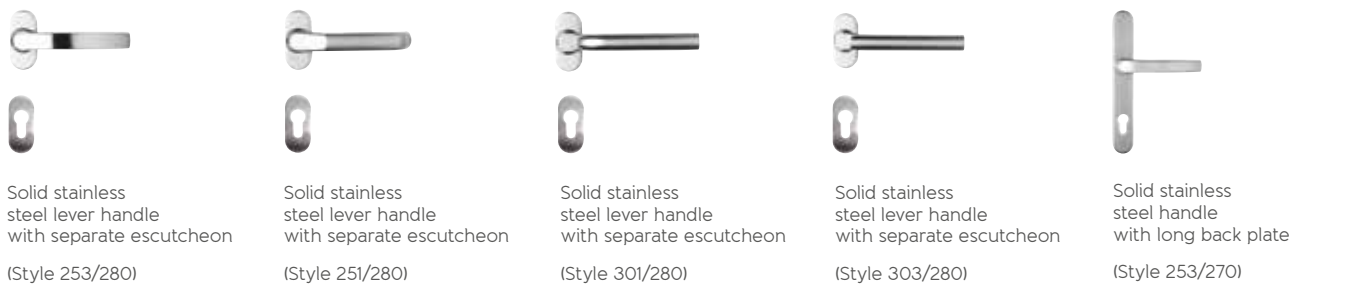

Aluminium lever handles



Glazing Bars

The OB-72 is able to be specified with traditional glazing bars or flat trim. The bars are placed on the glass after installation, and instantly offer a property more of a traditional style.



Door Make-Up

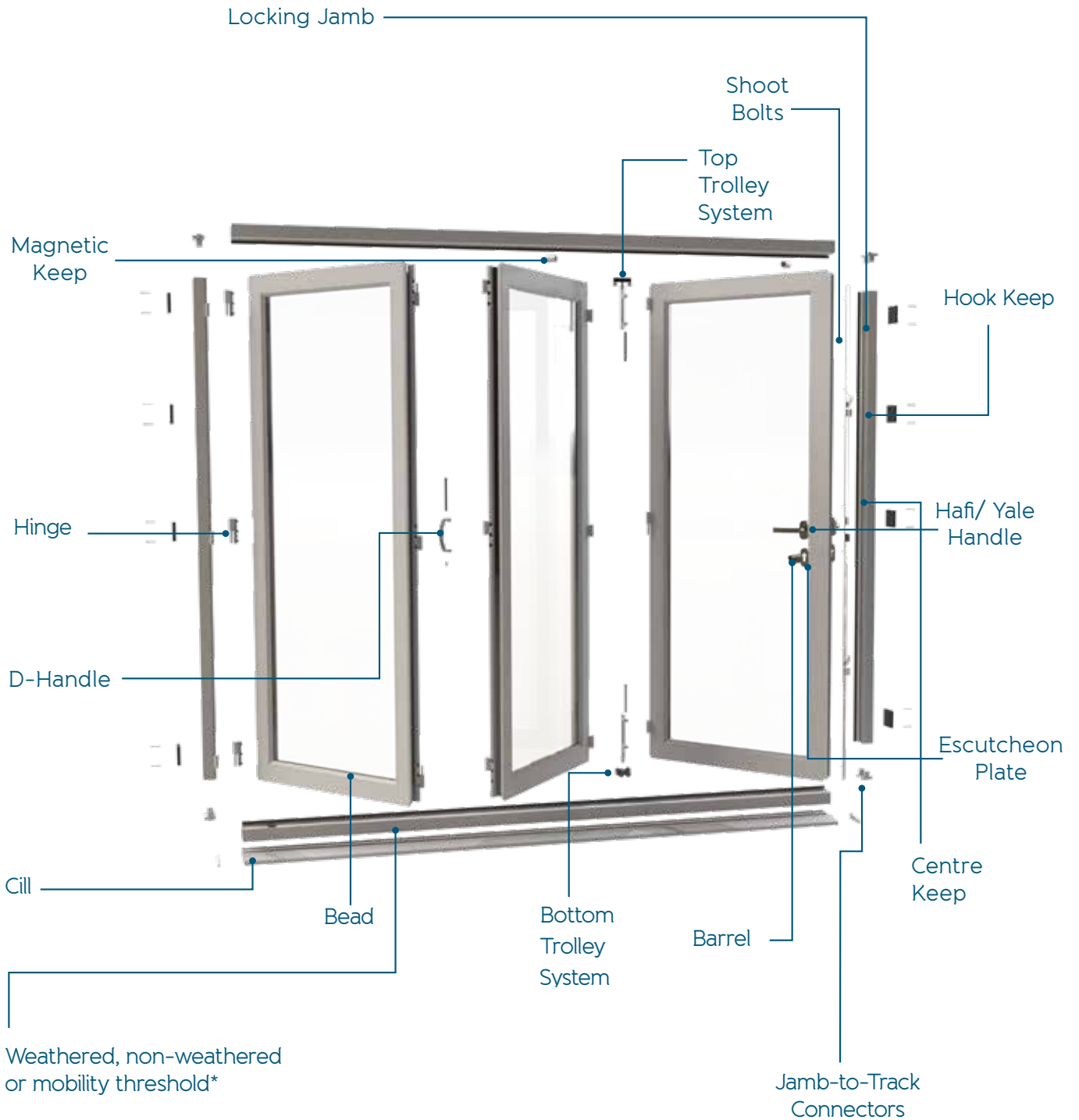

*Mobility threshold is only available on Single and French Doors

Size Limitations

Individual door/ sash sizes

	Width	Height
Minimum Sash Size (mm)	325	400
Maximum Sash Size (mm)	1200	2876
Minimum Sash Size (mm) With multi-point lock	325	1000
Maximum Sash Size (mm) With multi-point lock	1200*	2876
Minimum Sash Size (mm) Even sets going in one direction	700	1000
Maximum Sash Size (mm) Even sets going in one direction	1200*	2876

▶ Maximum sash weight - 76kg (this is dependent on the lateral loading)

Set sizes

Min Height	524mm
Min Width	449mm (single doors)
Max Height	3000mm
Max Width	27600mm (with joining tracks)

▶ Maximum steel deflection -3mm

Configuration table

approximate opening

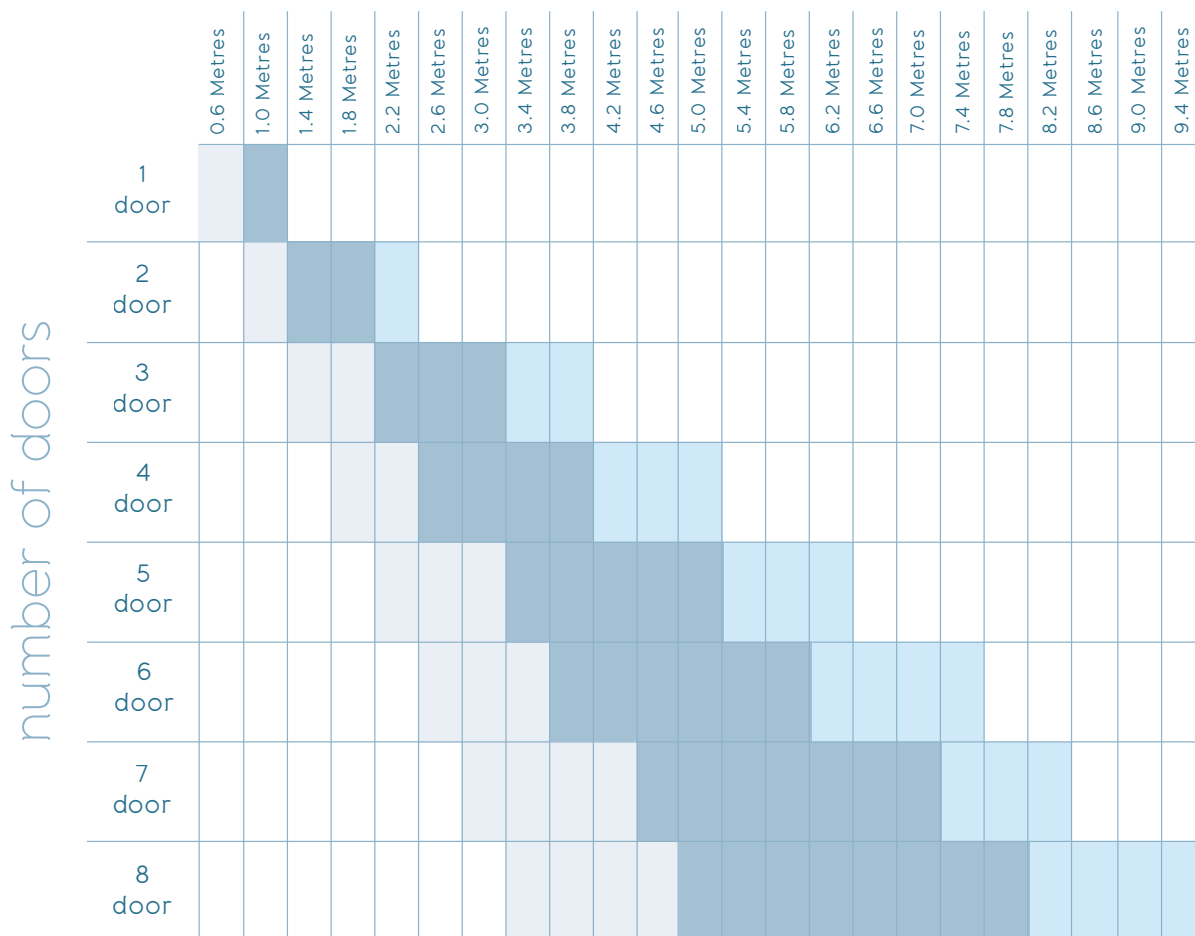

The door width and height may vary depending on the configuration chosen

The above sizes are for guidance only and are subject to glass specification.

The OB-72 is available with up to 12 sashes attached to one jamb.

Key:

 Optimum door leaf sizes	 Wide door leaf sizes	 Narrow door leaf sizes
--	---	---

Performance and Limitations

Origin Thermal Ratings

u-Value

OB-72 Double Glazed	1.6 W/m ² K
OB-72 Triple Glazed (with krypton)	1.3 W/m ² K
OB-72 Triple Glazed (with argon)	1.5 W/m ² K
Energy Rating	up to C

Glazing

u-Value

28mm, 1.2 centre pane ●	1.8 W/m ² K ●
28mm, 1.1 centre pane ●	1.6 W/m ² K ●
32mm, 1.2 centre pane ●	1.8 W/m ² K ●
32mm, 1.0 centre pane ●	1.6 W/m ² K ●
32mm, triple, 0.8 centre pane ●	1.4 W/m ² K ●
32mm, triple, 0.5 centre pane ●	1.3 W/m ² K ●

- Clear - Warm Edge Spacer - Planitherm Total+, Pilkington K, Etc
- Clear - Warm Edge Spacer - Planitherm 4S2, Pilkington Optitherm, Etc
- Argon Gas Fill
- Krypton Gas Fill

Weather Rating

Doors up to 2699mm

Doors over 2700mm

Air Permeability	Class 4, 600pa	Class 3, 600pa
Resistance to Wind Load	Class A3, 1200pa	Class A2, 800pa
Water Tightness	Class 9A	Class 5A
Exposure Category	1200 Special	800 Special

Performance Testing

PAS 24:2016

BS 6375 Parts 1, 2 & 3

Secured by Design accredited

Passed 50,00 lead door cycles and 10,000 full cycles, equating to 25 years of use

Building Regulation Requirements

New Build
and Extensions 2.0 W/m²K

Replacements 1.8 W/m²K

Energy Rating E or better

All doors must conform to these requirements.

Thermal Efficiency

The OB-72 exceeds British Building Regulation requirements for optimum thermal efficiency. With u-Values as low as 1.3, the OB-72 comprises of some of the most sophisticated weather-tight seals to ensure the elements stay out.

See pages 14-20 for more information on thermal efficiency and weather ratings.

OB-72

Certificate of thermal simulation

PRODUCT:	OB-72
SIM - SOFTWARE:	Win Iso 2D Pro
GLASS SPECIFICATION AND CENTRE PANE U/VALUE VALUE:	0.510 W/m ² K (32mm triple glazing)

Thermal Transmittance:
1.3 W/(m²K)

TESTED BY: David Ginger (Product Compliance Director)

DATE: May 2015

SIGNED: 

All simulations strictly in accordance with the requirements of ISO 10077-2:2015

Email: enquiry@origin-global.com | Web: www.origin-global.com

Origin Global HQ, Stuart House, Castle Estate, Coronation Road,
Cressex Business Park, High Wycombe, Buckinghamshire, HP12 3TA

OFDL_18.149.1

origin
DOORS AND WINDOWS

OB-72

Certificate of thermal simulation

PRODUCT:	OB-72
SIM - SOFTWARE:	Win Iso 2D Pro
GLASS SPECIFICATION AND CENTRE PANE U/VALUE VALUE:	0.784 W/m ² K (32mm triple glazing)

Thermal Transmittance:
1.5 W/(m²K)

TESTED BY: David Ginger (Product Compliance Director)

DATE: February 2015

SIGNED: 

All simulations strictly in accordance with the requirements of ISO 10077-2:2015

Email: enquiry@origin-global.com | Web: www.origin-global.com

Origin Global HQ, Stuart House, Castle Estate, Coronation Road,
Cressex Business Park, High Wycombe, Buckinghamshire, HP12 3TA

OFDL_18.149.1

origin
DOORS AND WINDOWS

OB-72

Certificate of thermal simulation

PRODUCT:	OB-72
SIM - SOFTWARE:	Win Iso 2D Pro
GLASS SPECIFICATION AND CENTRE PANE U/VALUE VALUE:	1.046 W/m ² K (28mm double glazing)

Thermal Transmittance:
1.6 W/(m²K)

TESTED BY: David Ginger (Product Compliance Director)

DATE: February 2015

SIGNED: 

All simulations strictly in accordance with the requirements of ISO 10077-2:2015

Email: enquiry@origin-global.com | Web: www.origin-global.com

Origin Global HQ, Stuart House, Castle Estate, Coronation Road,
Cressex Business Park, High Wycombe, Buckinghamshire, HP12 3TA

OFDLJ8149.1

origin
DOORS AND WINDOWS

OB-72

Classification of weather tightness

PRODUCT TESTED: Origin Bi-folding Door

- Air permeability tests in accordance with BS EN 1026:2000
- Watertightness test in accordance with BS EN 1027:2000
- Wind resistance tests in accordance with BS EN 12211:2000
- Exposure category classification in accordance with BS 6375-1:2009 (clauses ,7 and 8)

Results:

UK exposure category	Air permability		Water tightness		Resistance to wind load			
	Class	Maximum test pressure	Class	Maximum test pressure	Class	P1	P2	P3
1200	4	600 Pa	9A	600 Pa	A3	1200	600	1800

TESTED BY: Build Check Ltd

REFERENCE: W14060-1

DATE: 28/03/14

Email: enquiry@origin-global.com | Web: www.origin-global.com

Origin Global HQ, Stuart House, Castle Estate, Coronation Road,
Cressex Business Park, High Wycombe, Buckinghamshire, HP12 3TA

OFDL_18.149.1

origin
DOORS AND WINDOWS

OB-72

Classification of weather tightness

PRODUCT TESTED: Origin Bi-folding Door (2725 - 3025mm Tall inc. Cill)

- Air permeability tests in accordance with BS EN 1026:2000
- Watertightness test in accordance with BS EN 1027:2000
- Wind resistance tests in accordance with BS EN 12211:2000
- Exposure category classification in accordance with BS 6375-1:2009 (clauses ,7 and 8)

RESULTS:

UK exposure category	Air permability		Water tightness		Resistance to wind load			
	Class	Maximum test pressure	Class	Maximum test pressure	Class	P1	P2	P3
800	3	600 Pa	5A	200 Pa	A2	800	400	1200

TESTED BY: Build Check Ltd

REFERENCE: W17183-1

DATE: 14/08/2017

Email: enquiry@origin-global.com | Web: www.origin-global.com

Origin Global HQ, Stuart House, Castle Estate, Coronation Road,
Cressex Business Park, High Wycombe, Buckinghamshire, HP12 3TA

OFDL_18149.1

origin
DOORS AND WINDOWS

OB-72

Certificate of thermal simulation

PRODUCT TESTED:	Origin Bifold Door
Head Frame Identifier:	Origin Door Head & Sill
Meeting Rail Frame Identifier:	Origin Door Meeting Rail
Left Jamb Frame Identifier:	Origin Door Jamb
Lock Jamb Frame Identifier:	Origin Door Lock Jamb
Sill Frame Identifier:	Origin Door Head & Sill
Glass Make up	24 Diamant 90% Argon Planitherm Total +
Spacer Bar:	16mm Super Spacer Standard

Results

BFRC Energy Rating Band	D	
Air Leakage Factor	0	W/(m ² K)
BFRC Energy Rating Index	-27	
Solar Factor	0.46	



BFRC Certified Simulator 016

TESTED BY: Therm Consulting Ltd

REFERENCE: TCL2014-Origin-001

DATE: 14/02/2014

All simulations strictly in accordance with the requirements of ISO 10077-2:2015

Email: enquiry@origin-global.com | Web: www.origin-global.com

Origin Global HQ, Stuart House, Castle Estate, Coronation Road,
Cressex Business Park, High Wycombe, Buckinghamshire, HP12 3TA

OFDL_18.148.1



OB-72

Classification of weather tightness

PRODUCT TESTED: Origin Bi-folding Door

- Air permeability tests in accordance with BS EN 1026:2000
- Watertightness test in accordance with BS EN 1027:2000
- Wind resistance tests in accordance with BS EN 12211:2000
- Exposure category classification in accordance with BS 6375-1:2009 (clauses ,7 and 8)

Results:

UK exposure category	Air permeability		Water tightness		Resistance to wind load			
	Class	Maximum test pressure	Class	Maximum test pressure	Class	P1	P2	P3
1200	4	600 Pa	9A	600 Pa	A3	1200	600	1800

TESTED BY: Build Check Ltd

REFERENCE: W14060-1

DATE: 28/03/14

Email: enquiry@origin-global.com | Web: www.origin-global.com

Origin Global HQ, Stuart House, Castle Estate, Coronation Road,
Cressex Business Park, High Wycombe, Buckinghamshire, HP12 3TA

OFDLJ8149.1



OB-72

Certificate of PAS 24

PRODUCT: ORIGIN BI-FOLD OB-72

SUMMARY OF TESTING PROCEDURE:

PAS 24: 2016 - CLAUSE ANNEX A, B.4.3, B.4.4.2, B.4.4.3,
B.4.4.4, B.4.5, B.4.6, B.4.8 AND B.4.9.2.2

RESULT:

PASS

PASSED PAS 24: 2016 FOR THE REQUIREMENTS OF BOTH 3 STAR KEY
REMOVABLE AND THUMBTURN CYLINDERS.

TO COMPLY, A BSEN 356 P1A CERTIFIED GLASS UNIT
MUST BE INSTALLED.

Secured by Design



Police Preferred Specification

TESTED BY: Build Check Ltd
REFERENCE: securedbydesign.com/member-companies/sbd-members
DATE: 01/08/2019

Email: enquiry@origin-global.com | Web: www.origin-global.com

Origin Global HQ, Stuart House, Castle Estate, Coronation Road,
Cressex Business Park, High Wycombe, Buckinghamshire, HP12 3TA

OFDL_18.144.1

origin
DOORS AND WINDOWS

Master Configurations

Master Configuration: single door

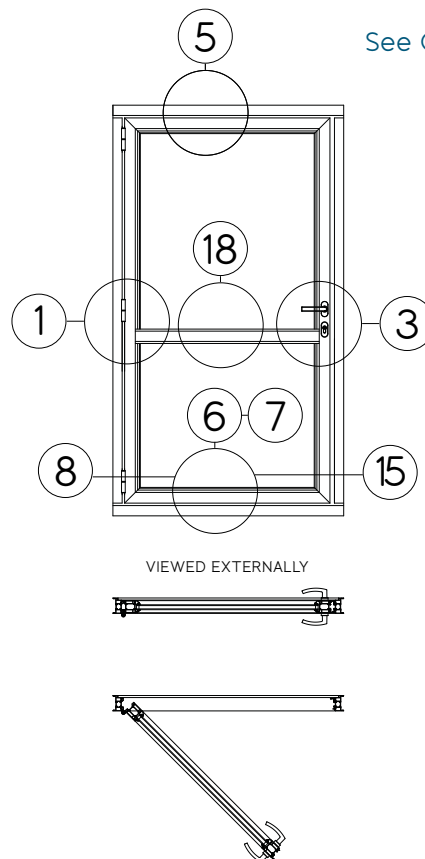

See Configuration Key for section detail ▶



Single Door

See page 71 for configurations

Key features

- ▶ Origin 8-point locking system depending on height
- ▶ Is able to be used for an everyday access door

Configuration Key

1a-1b - Hinge Jamb Detail

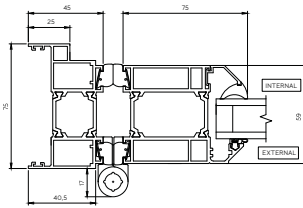

See page 36

3a-3b - Locking Jamb Detail

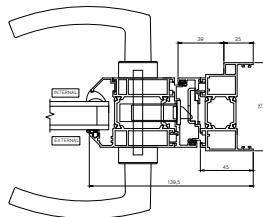

See page 38

5a-5b - Top Track Detail

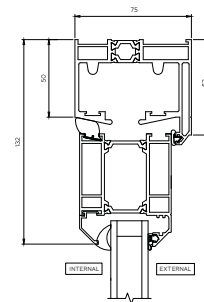

See page 40

6a-6d - Threshold and Drainage Details

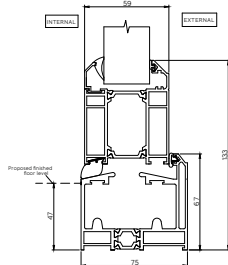

See pages 41 - 44

7a-7b - Non-Weathered Threshold Detail

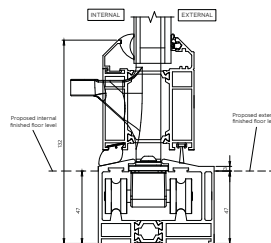

See page 45

8 - Mobility Threshold Detail

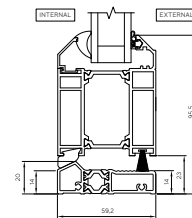

See page 46

15 - Cills

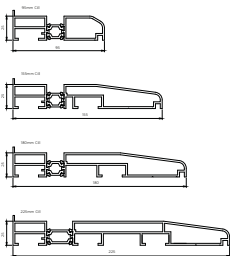

See page 53

18 - Midrail Detail

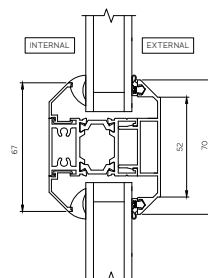

See page 56

Master Configuration: French door

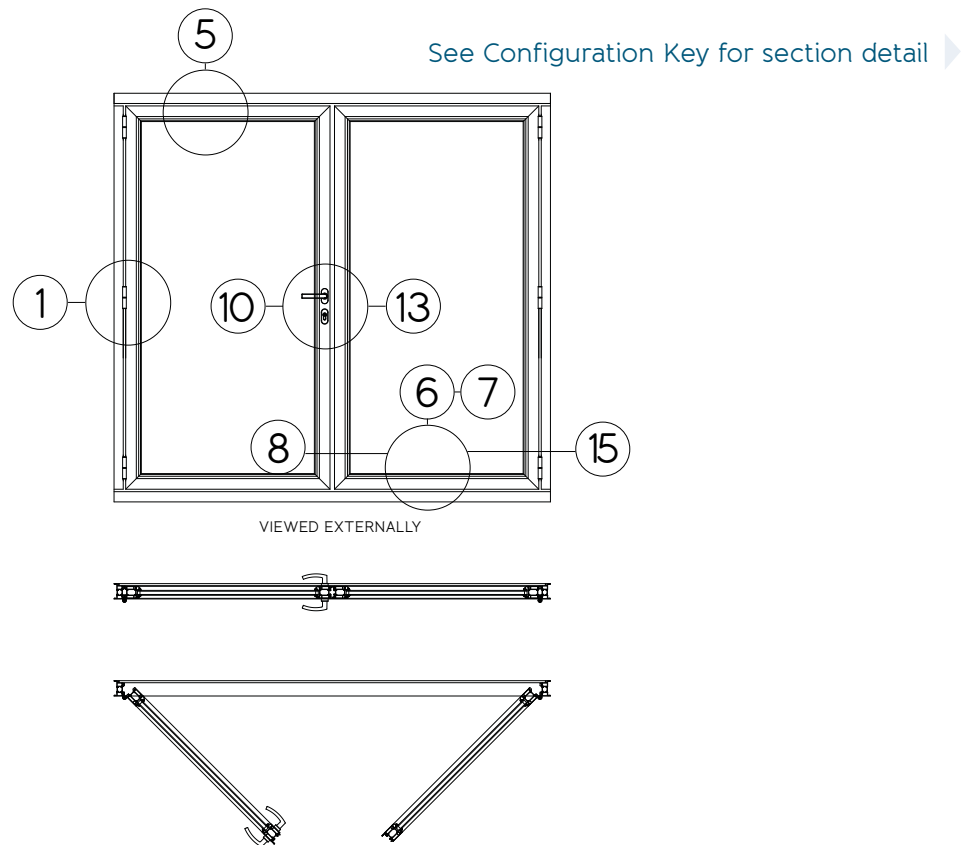

French Door

See page 71 for configurations

Key features

- ▶ Origin 8-point locking system depending on height

Configuration Key

1a-1b - Hinge Jamb Detail

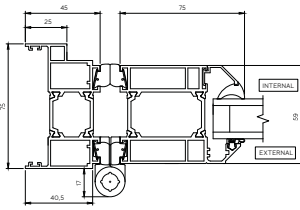

See page 36

5a-5b - Top Track Detail

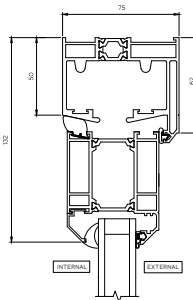

See page 40

6a-6d - Threshold and Drainage Details

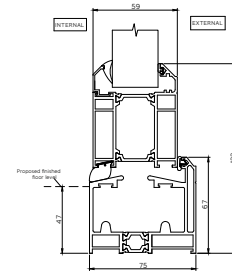

See pages 41 - 44

7a-7b - Non-Weathered Threshold Detail

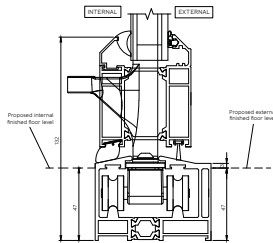

See page 45

8 - Mobility Threshold Detail

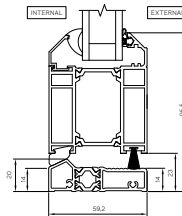

See page 46

10 - Locking Slave Detail

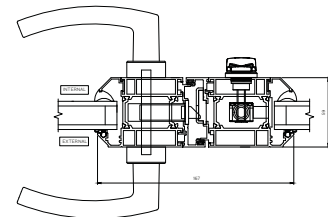

See page 48

13 - Locking Slave Handle Layout Detail

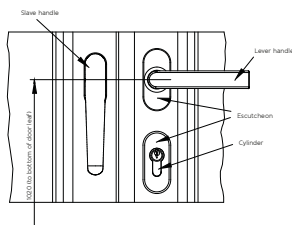

See page 51

15 - Cills

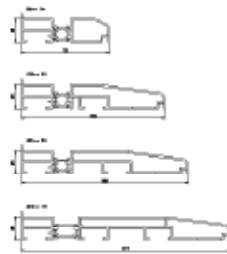

See page 53

Master Configuration: French door with fixed panels

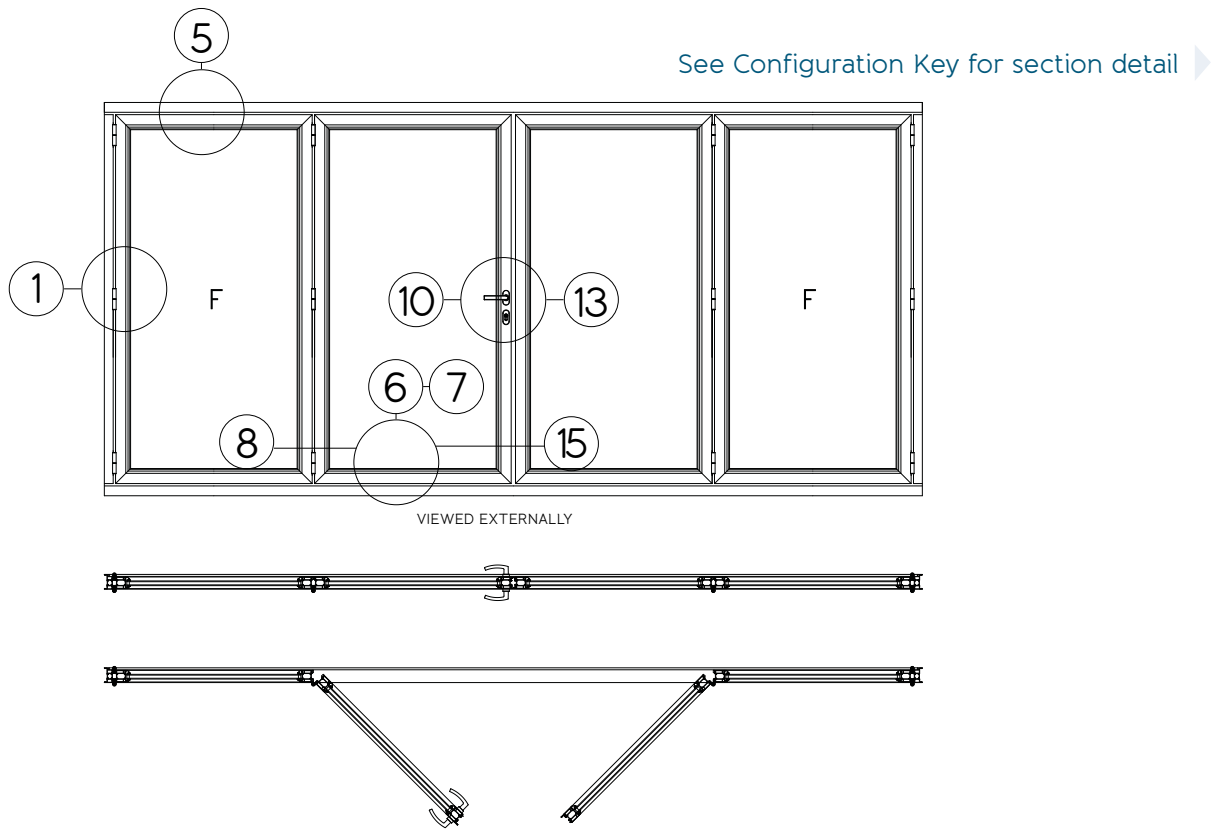

French Door with Fixed Panels

See page 71 for configurations

Key features

- ▶ Origin 8-point locking system depending on height
- ▶ Fixed panels and can vary in size
- ▶ Ideal for Juliette balconies

**Any fixed panels will be manufactured with dummy hinges for alignment and structural purposes, unless fixed windows are specified which will be coupled to the doors.*

Configuration Key

1a-1b - Hinge Jamb Detail

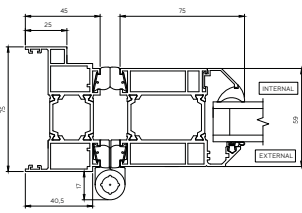

See page 36

5a-5b - Top Track Detail

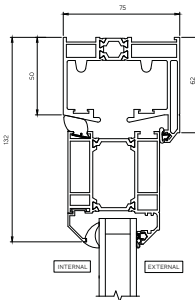

See page 40

6a-6d - Threshold and Drainage Details

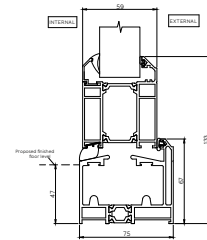

See pages 41 - 44

7a-7b - Non-Weathered Threshold Detail

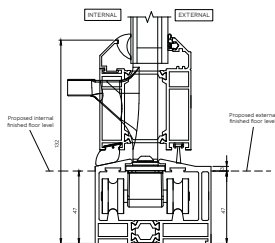

See page 45

8 - Mobility Threshold Detail

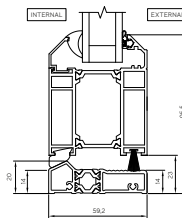

See page 46

10 - Locking Slave Detail

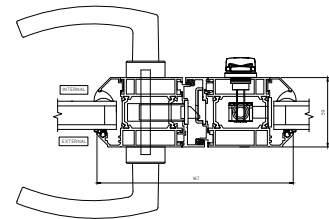

See page 48

13 - Locking Slave Handle Layout Detail

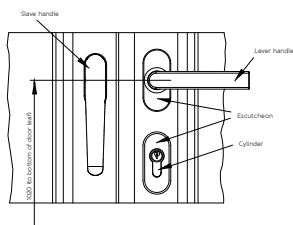

See page 51

15 - Cills

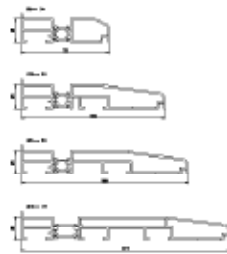

See page 53

Master Configuration: 2+0

Master drawing and all technical detail drawings are also applicable to the following configurations: 4+0, 6+0, 8+0

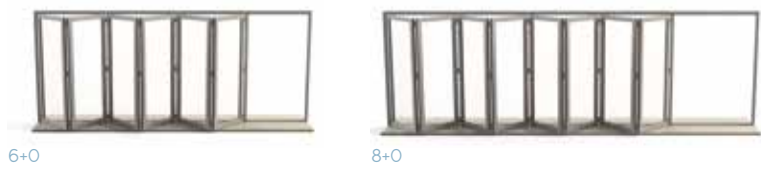
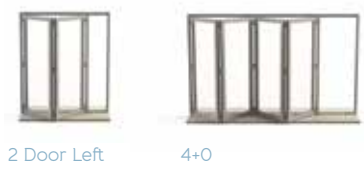
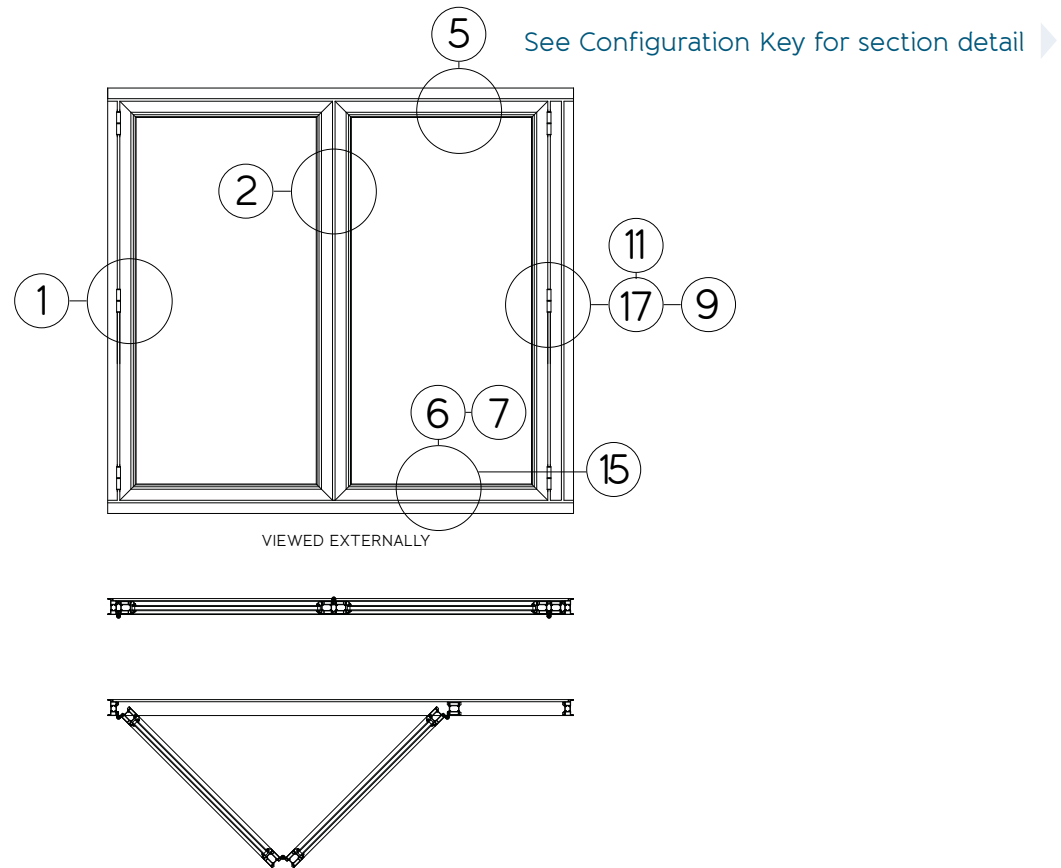

See page 71 for configurations

Key features

- ▶ All doors open in the same direction
- ▶ No multi-point lock available on this configuration
- ▶ Requires a mullion

Master Configuration: 3+0

Master drawing and all technical detail drawings are also applicable to the following configurations: 5+0, 7+0

See Configuration Key for section detail ▶

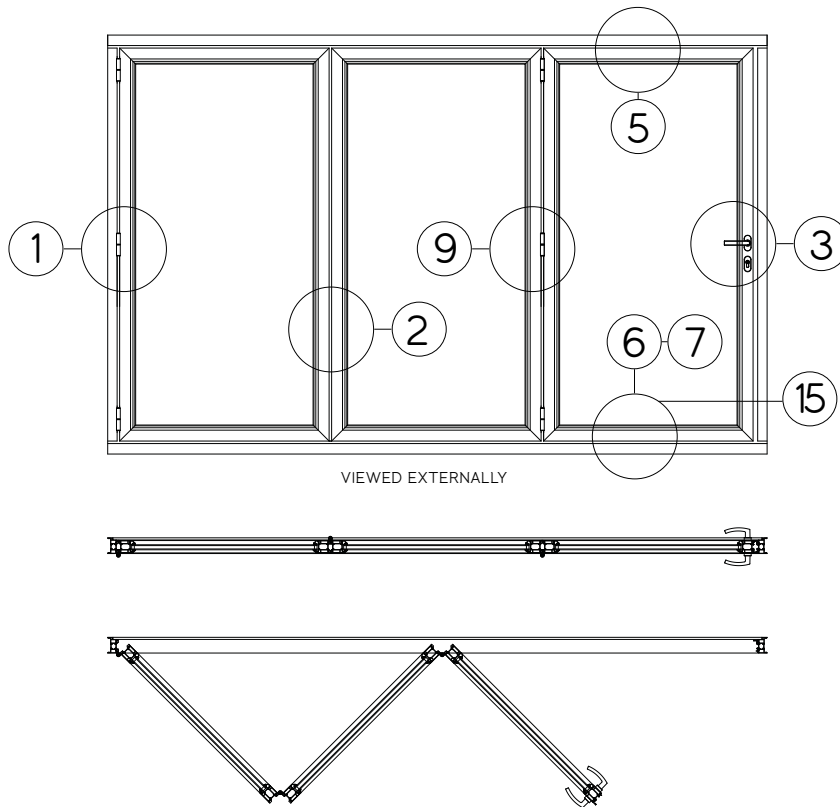

3 Door Left



5+0



7+0

See page 71 for configurations

Key features

- ▶ Origin 8-point locking system depending on height
- ▶ Everyday access door
- ▶ All doors open in the same direction

Configuration Key

1a-1b - Hinge Jamb Detail

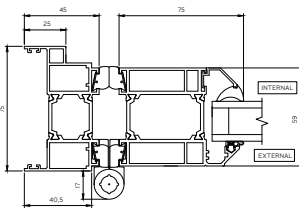

See page 36

2a-2b - Opening Stiles Detail

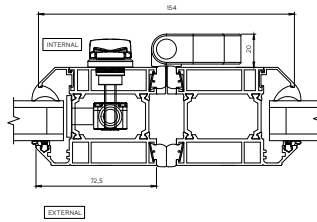

See page 37

3a-3b - Locking Jamb Detail

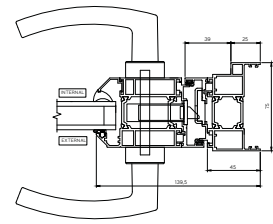

See page 38

5a-5b - Top Track Detail

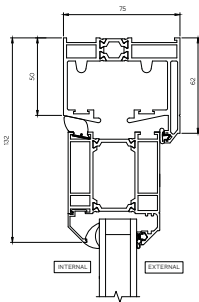

See page 40

6a-6d - Threshold and Drainage Details

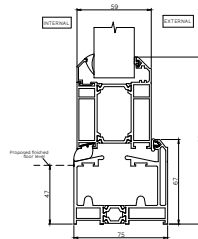

See pages 41 - 44

7a-7b - Non-Weathered Threshold Detail

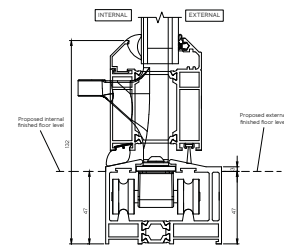

See page 45

9 - Slave Handle Layout

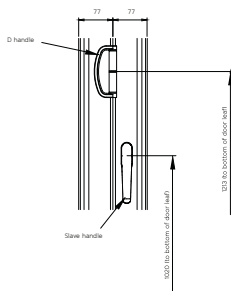

See page 47

15 - Cills

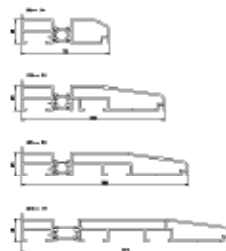

See page 53

Master Configuration: 3+2

Master drawing and all technical detail drawings are also applicable to the following configurations: 2+1, 4+1, 6+1, 4+3

See Configuration Key for section detail ▶

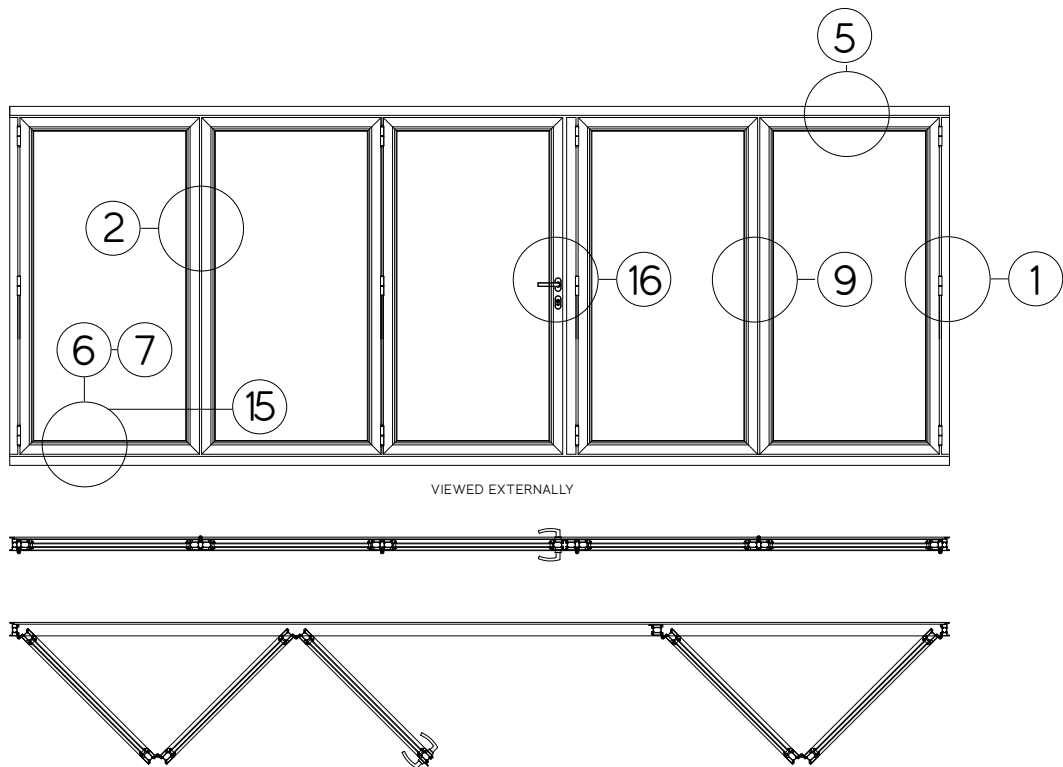

3+2 2+1

4+1 6+1

See page 71 for configurations

Key features

- ▶ Origin 8-point locking system depending on height
- ▶ Everyday access door
- ▶ Doors open to both sides

Master Configuration: 3+3

Master drawing and all technical detail drawings are also applicable to the following configurations: 3+1, 5+1, 5+3

See Configuration Key for section detail ▶

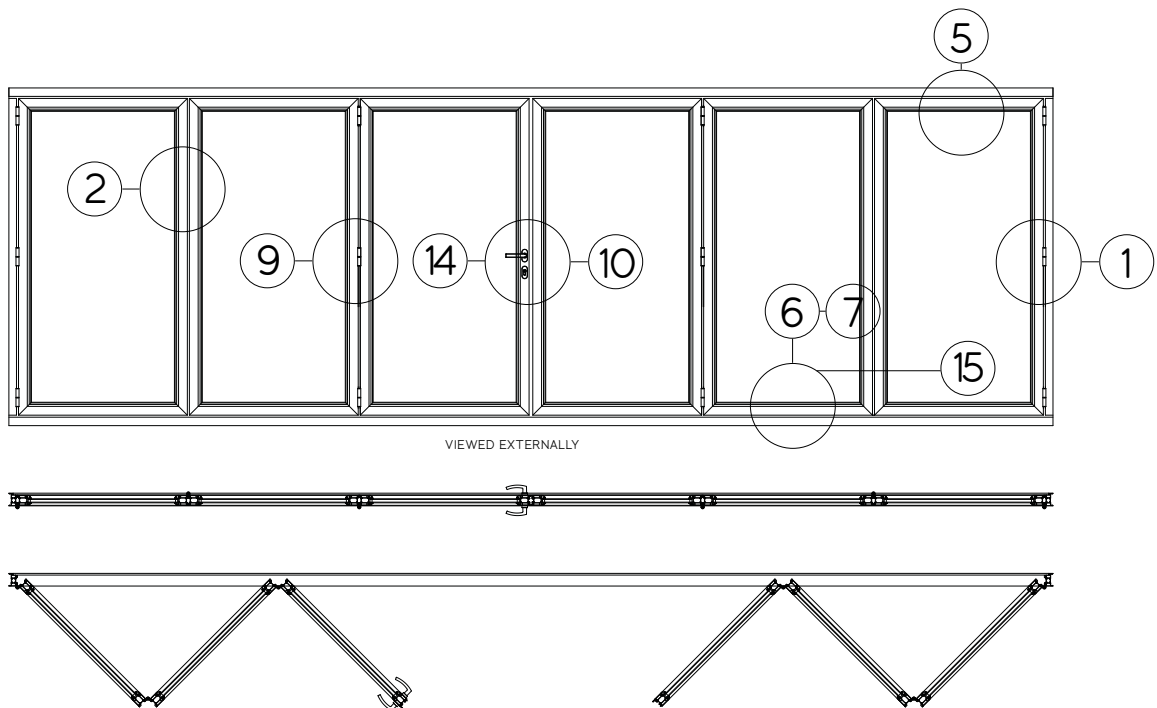

3+3

3+1

5+1

5+3

See page 71 for configurations

Key features

- ▶ Origin 8-point locking system depending on height
- ▶ Everyday access door
- ▶ Lead door and slave door can behave as French doors

Configuration Key

1a-1b - Hinge Jamb Detail

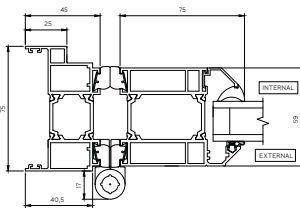

See page 36

2a-2b - Opening Stiles Detail

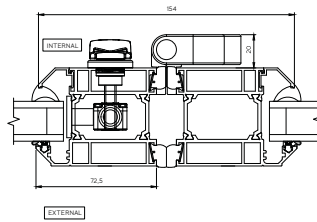

See page 37

5a-5b - Top Track Detail

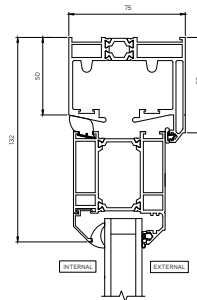

See page 40

6a-6d - Threshold and Drainage Details

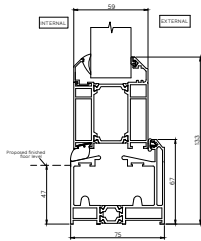

See pages 41 - 44

7a-7b - Non-Weathered Threshold Detail

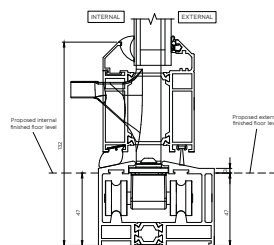

See page 45

9 - Slave Handle Layout

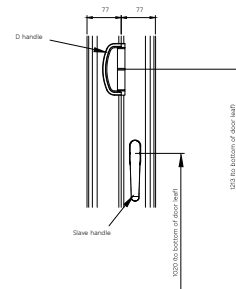

See page 47

10 - Locking Slave Detail

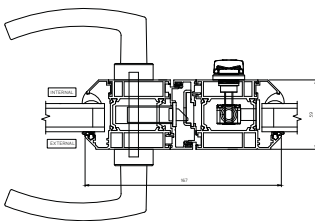

See page 48

14 - Locking Slave Handle Layout Detail

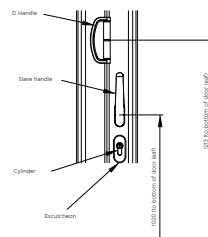

See page 52

15 - Cills

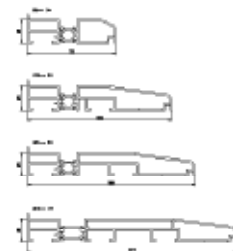

See page 53

Technical Drawings

1a-1b Hinge Jamb Detail

Open-in

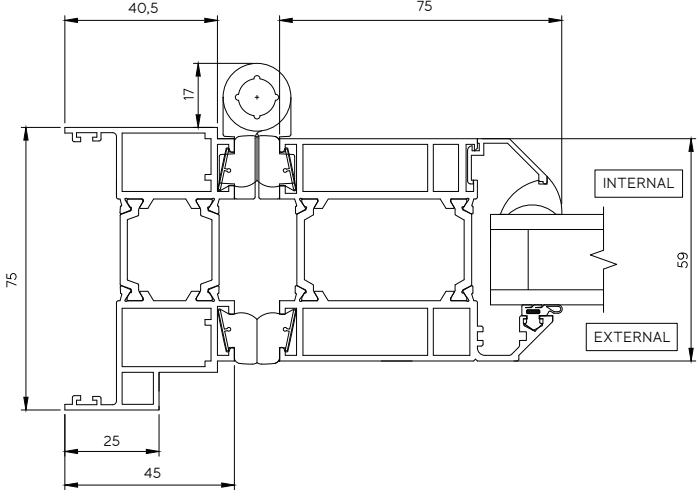

Open-out

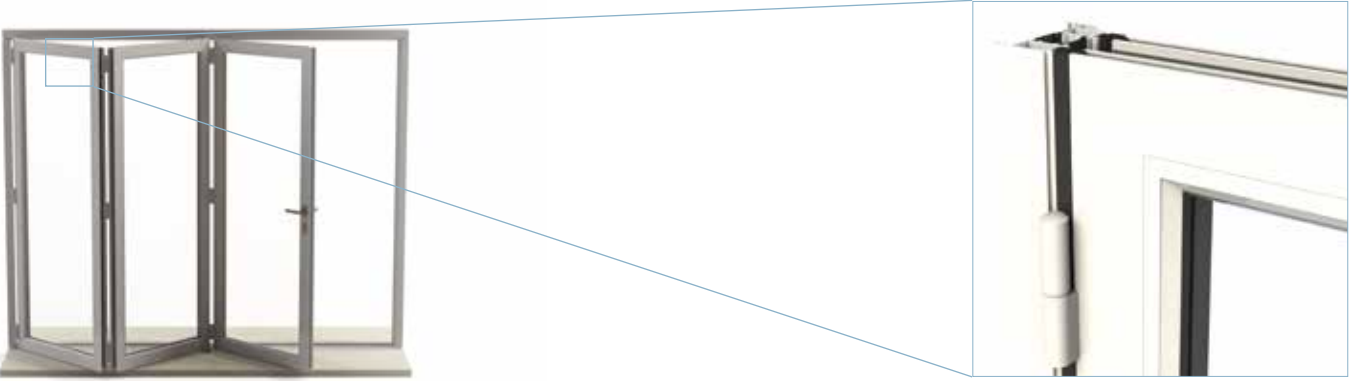
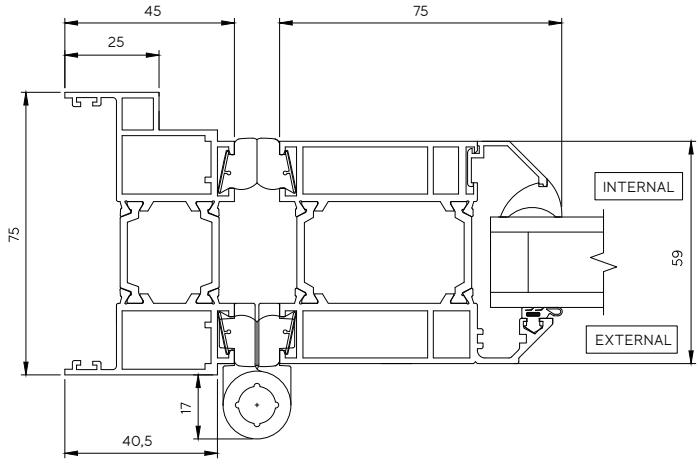

2a-2b Opening Stiles Detail

Open-in

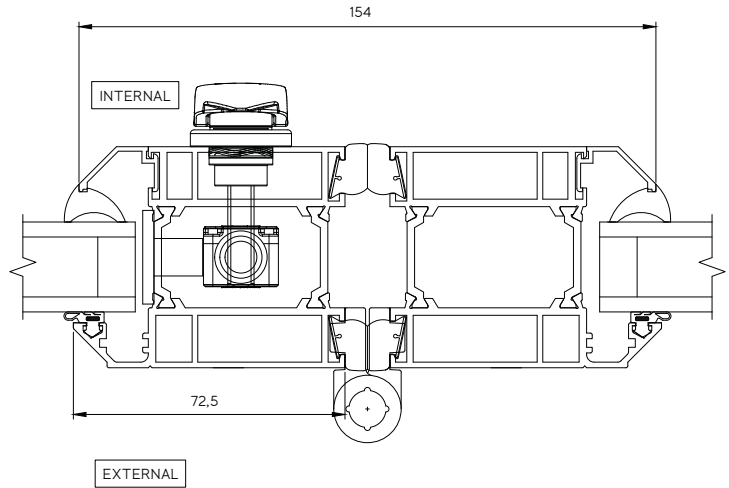

Open-out

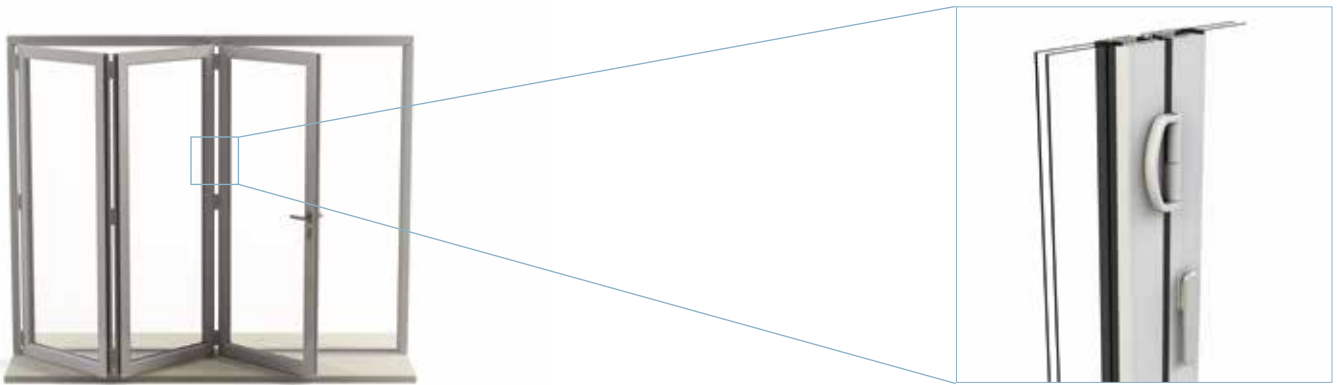
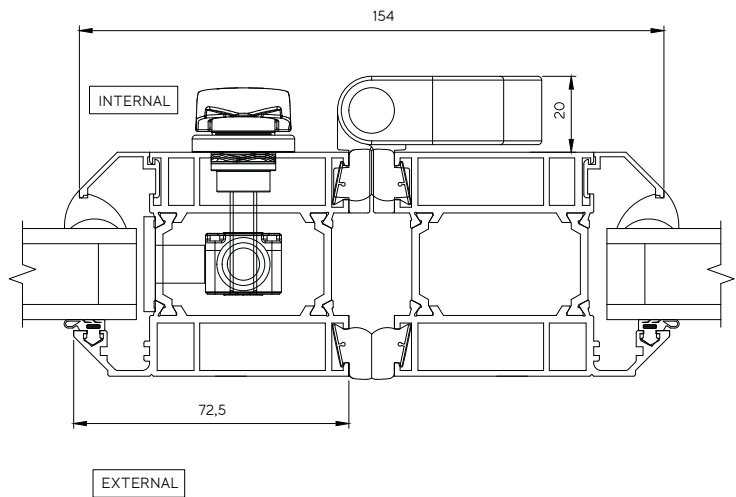

3a-3b Locking Jamb Detail

Open-in

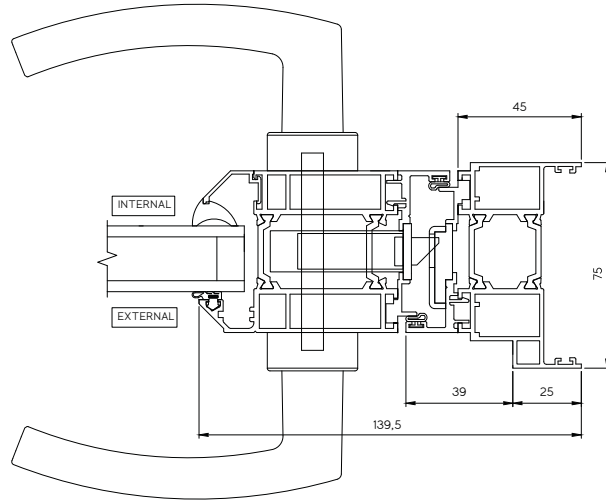

Open-out

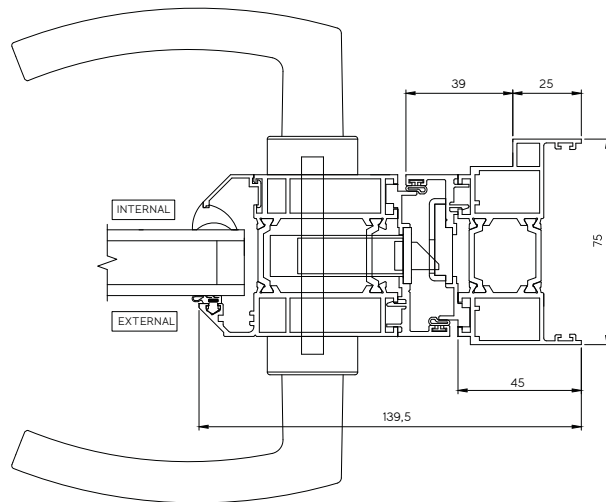

4 Jamb Fixing Detail

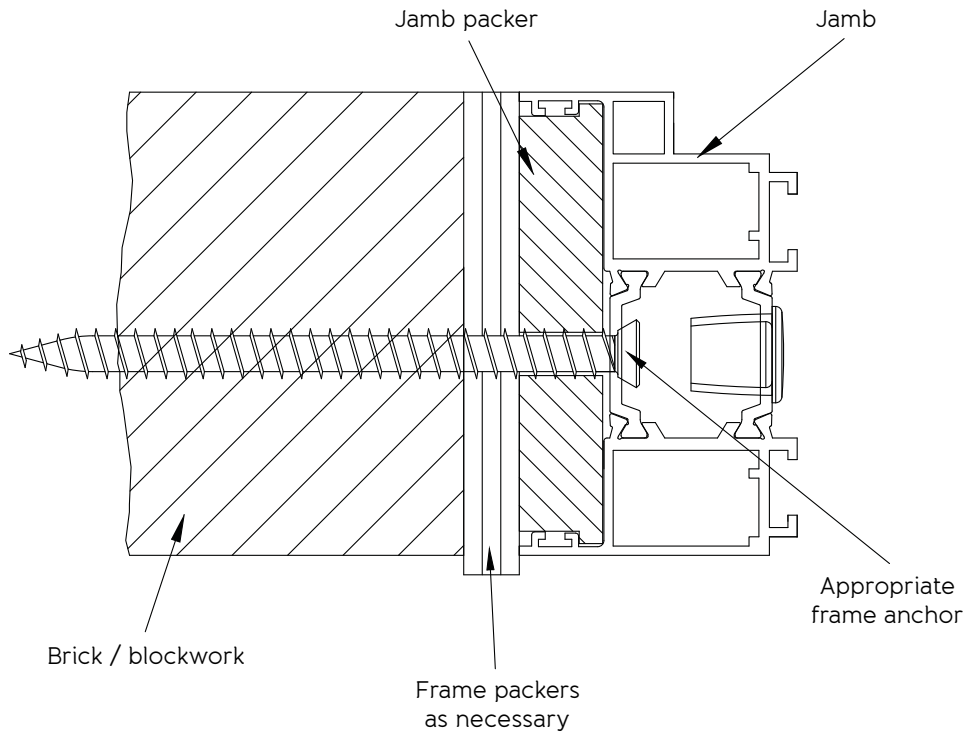

5a-5b Top Track Detail

Open-in

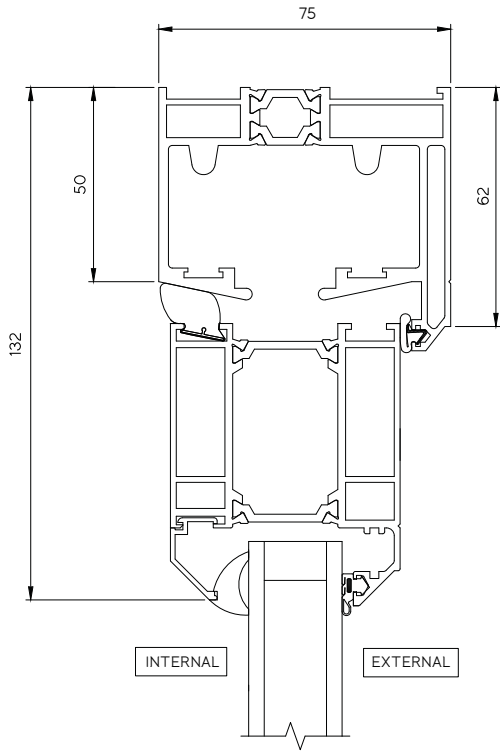

Open-out

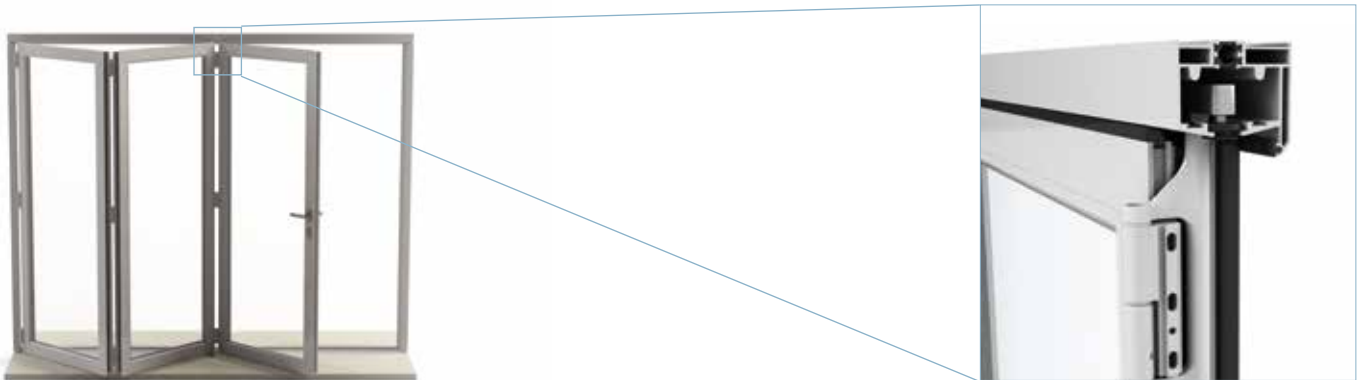
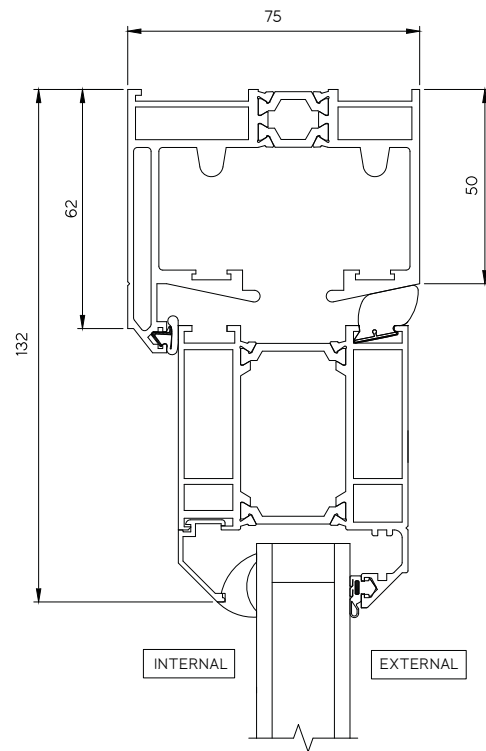

6a Threshold Detail On Single and French Doors

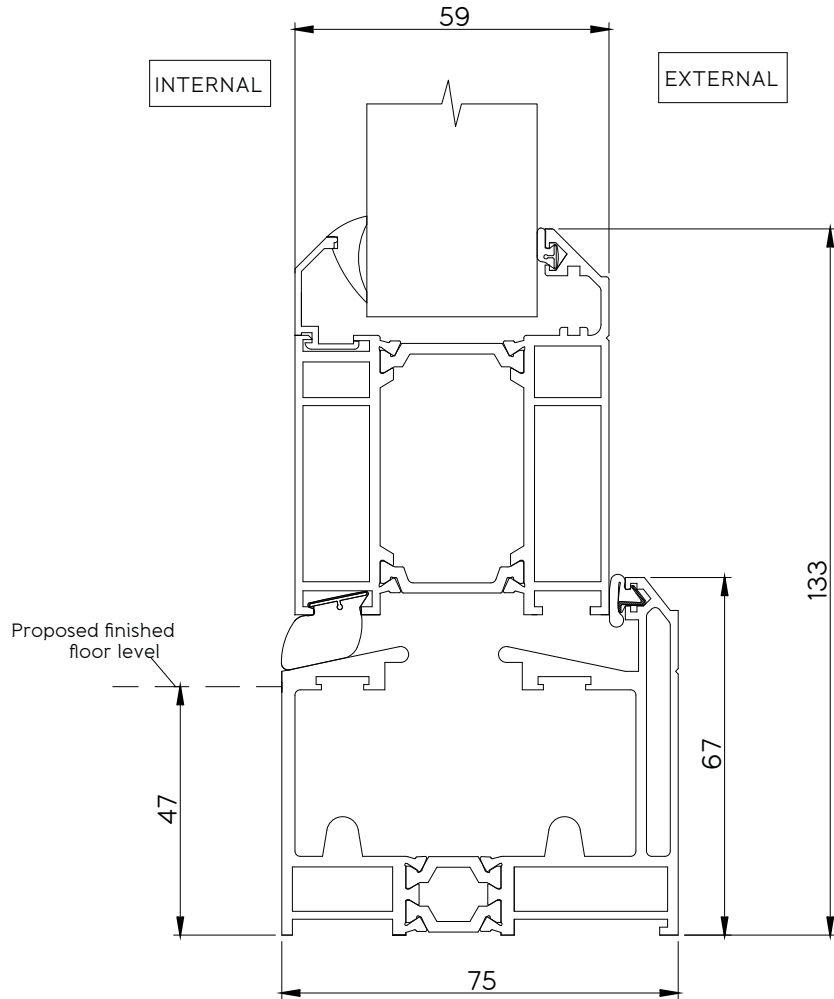

6b Face Drainage Threshold Detail

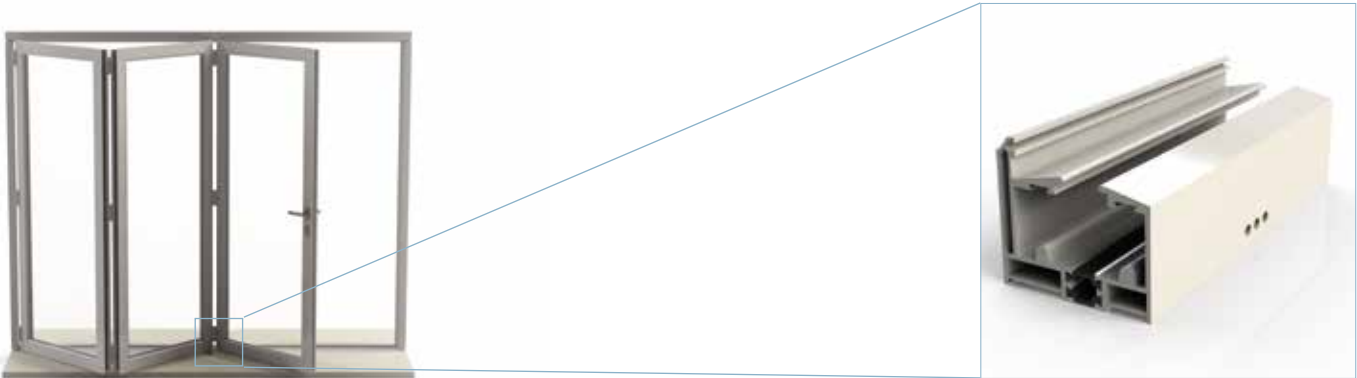
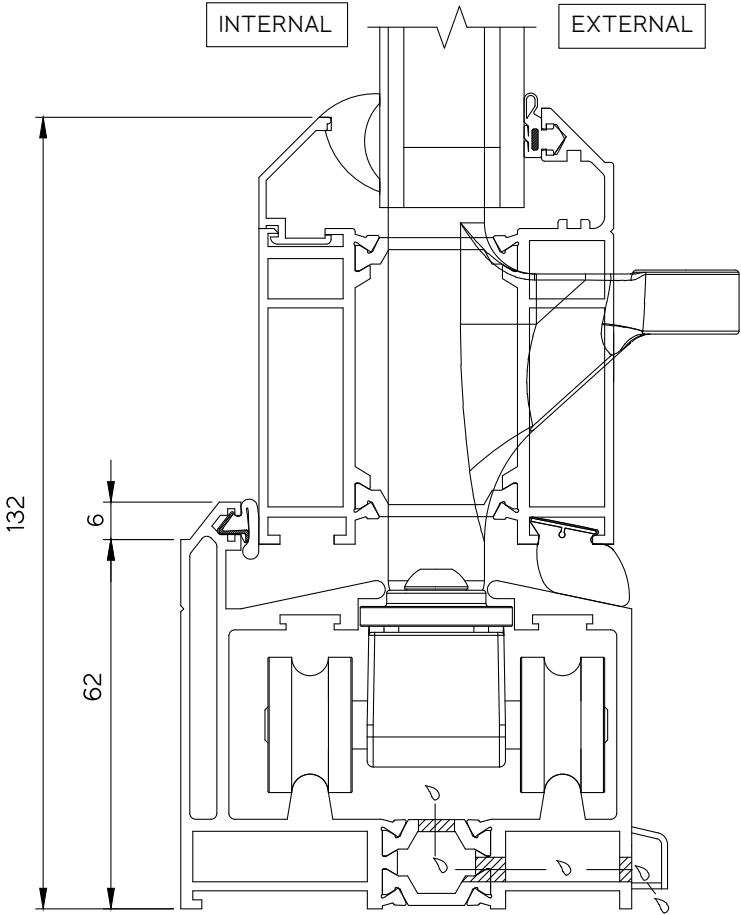

6c Concealed Drainage Threshold Detail

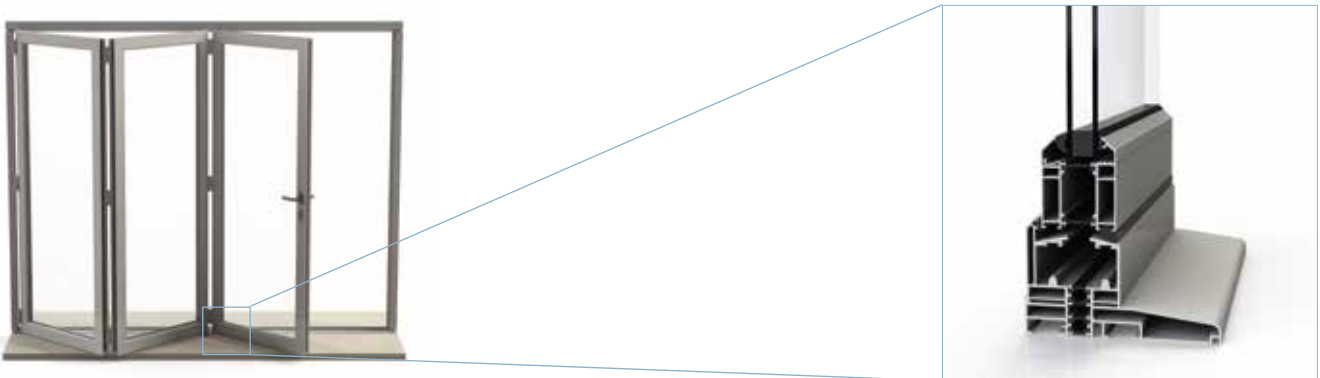
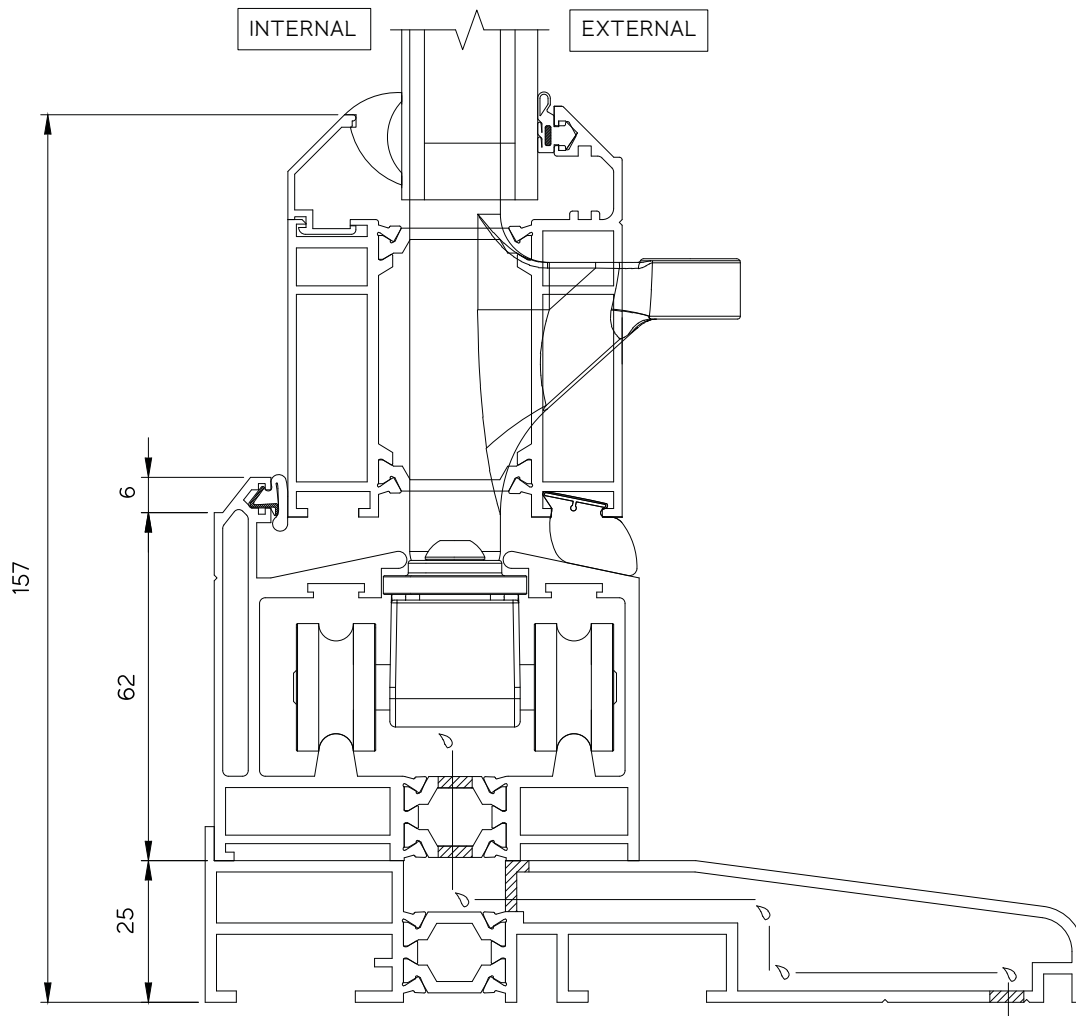

6d Bottom Track Fixing Detail

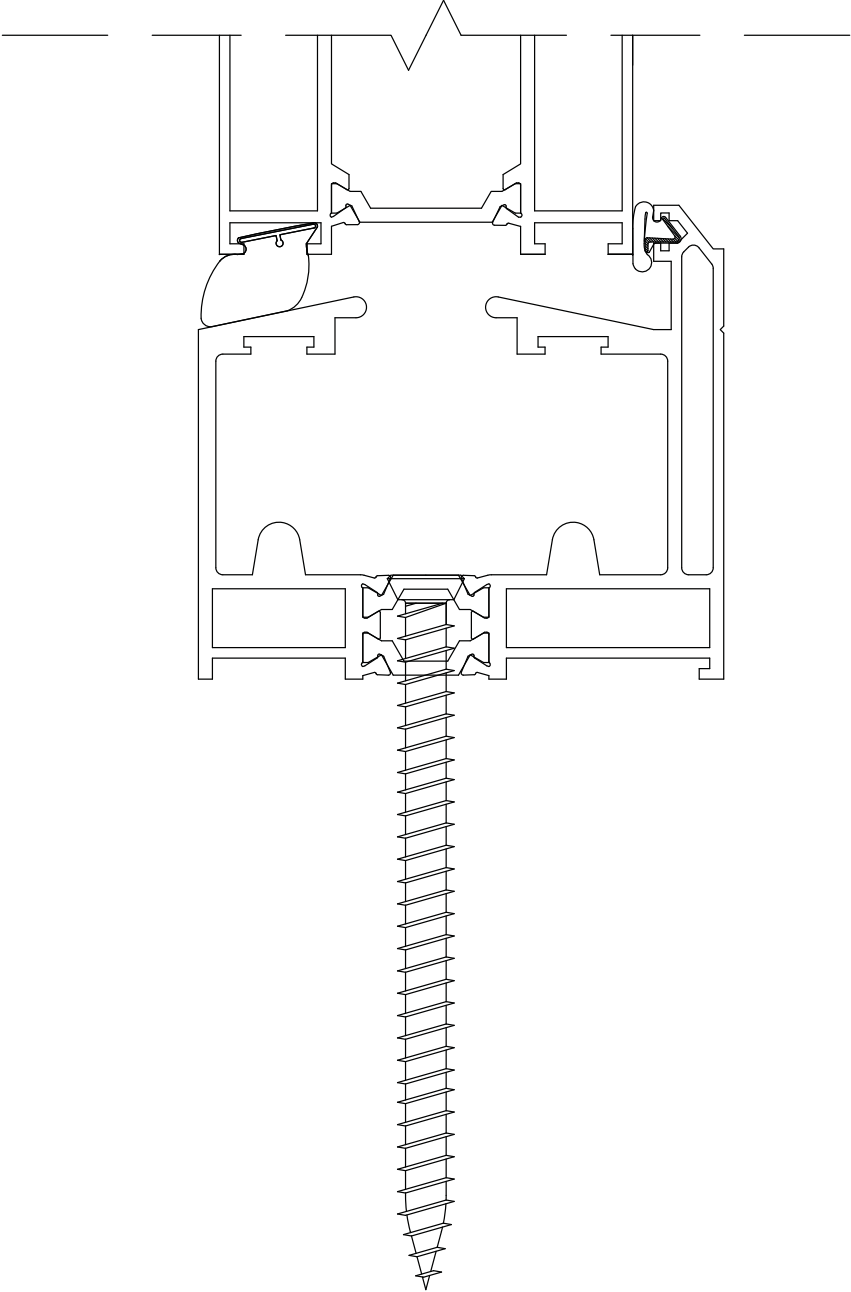

7a-7b Non-Weathered Threshold Detail

Open-in

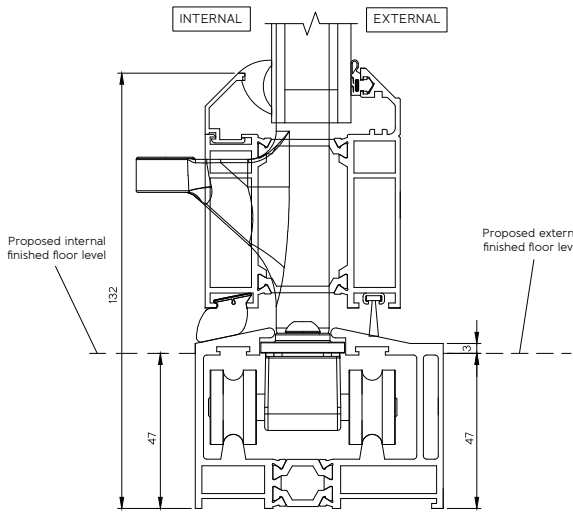

Open-out

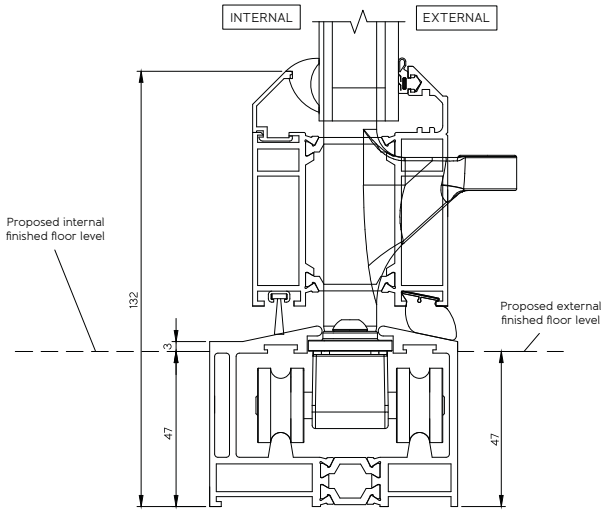

8 Mobility Threshold Detail

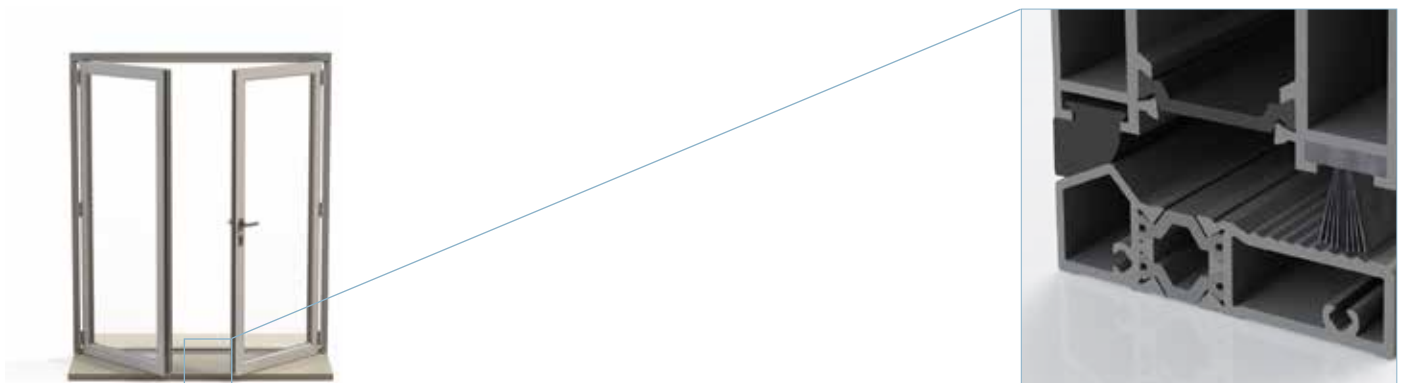
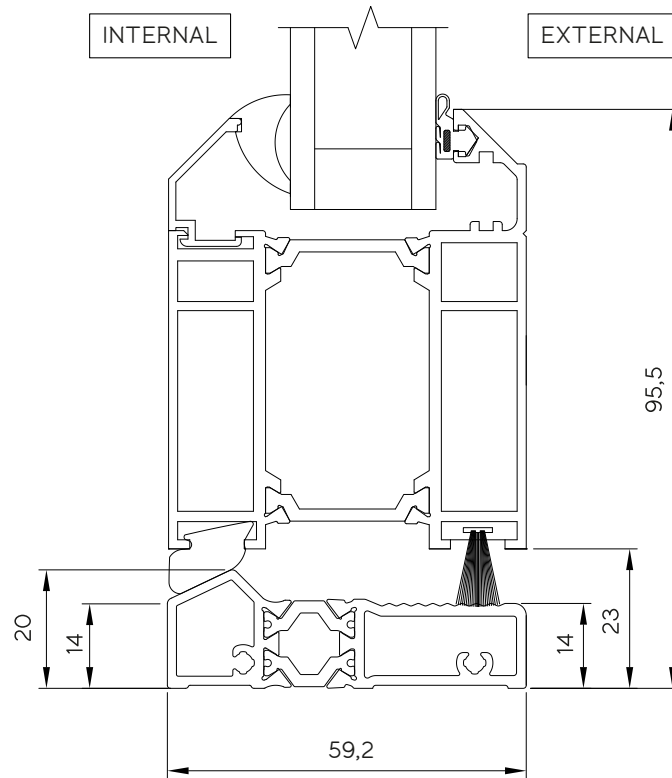

Mobility threshold only available on Single and French Doors.

9 Slave Handle Layout

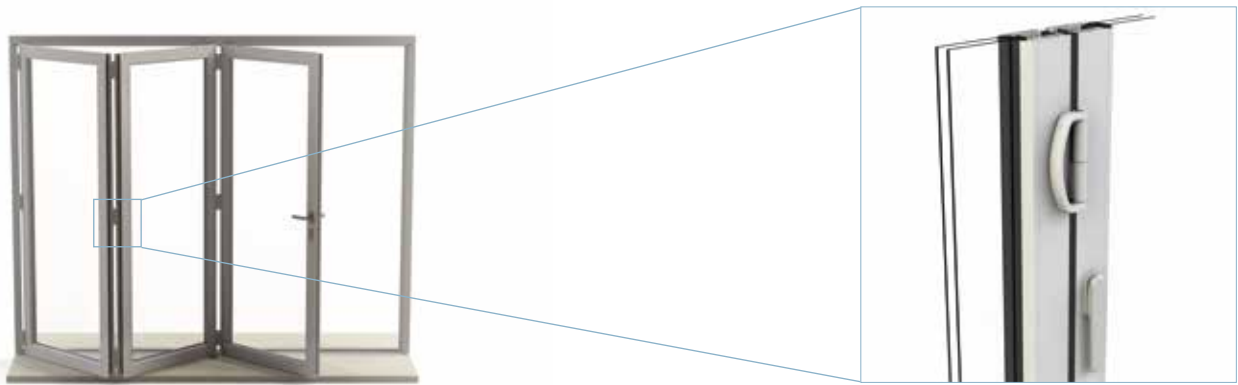
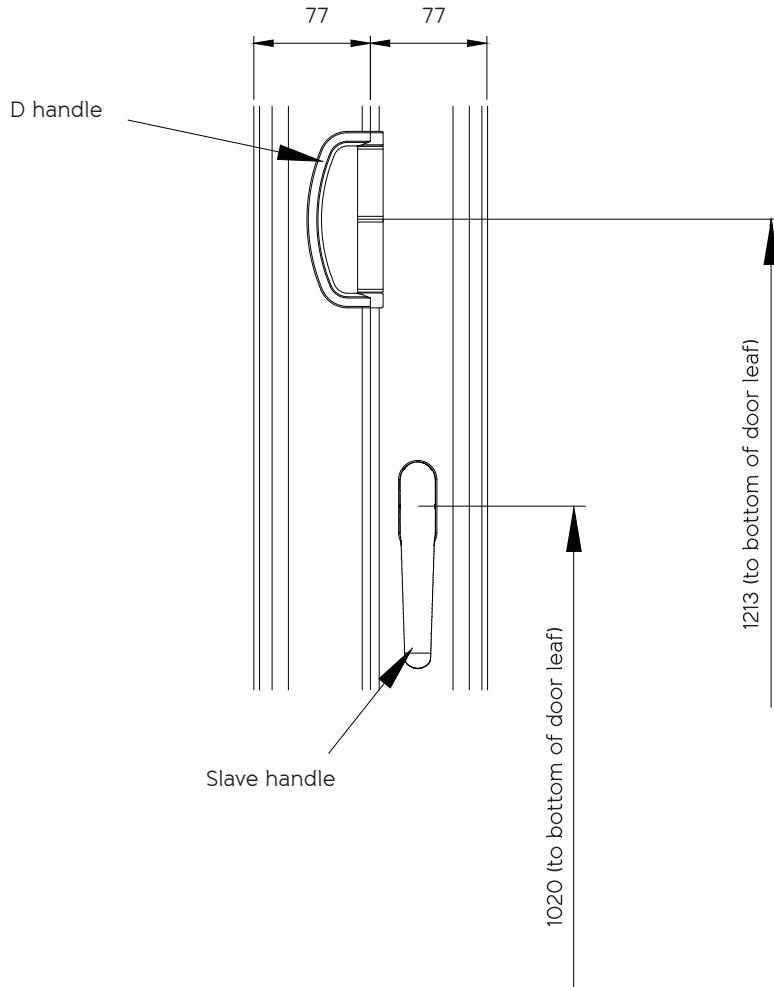

10 Locking Slave Detail

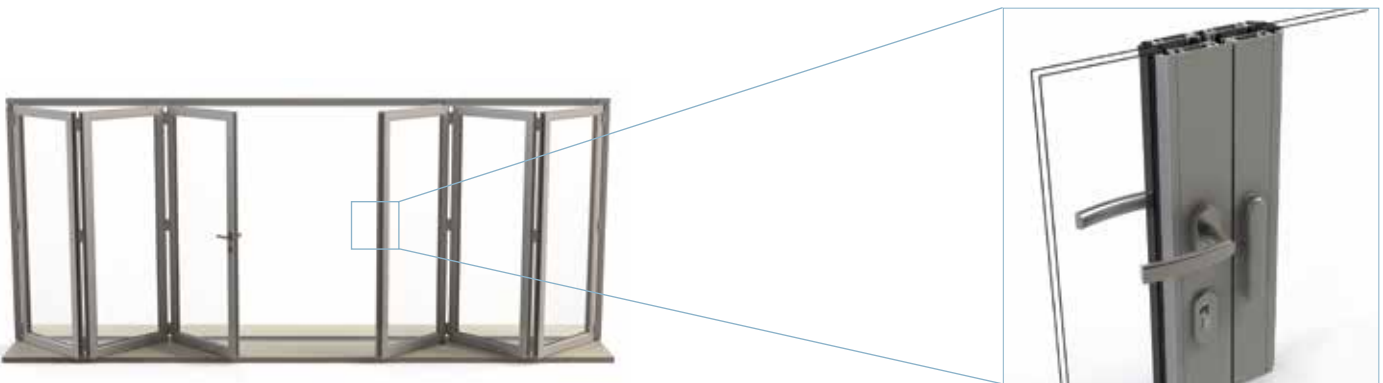
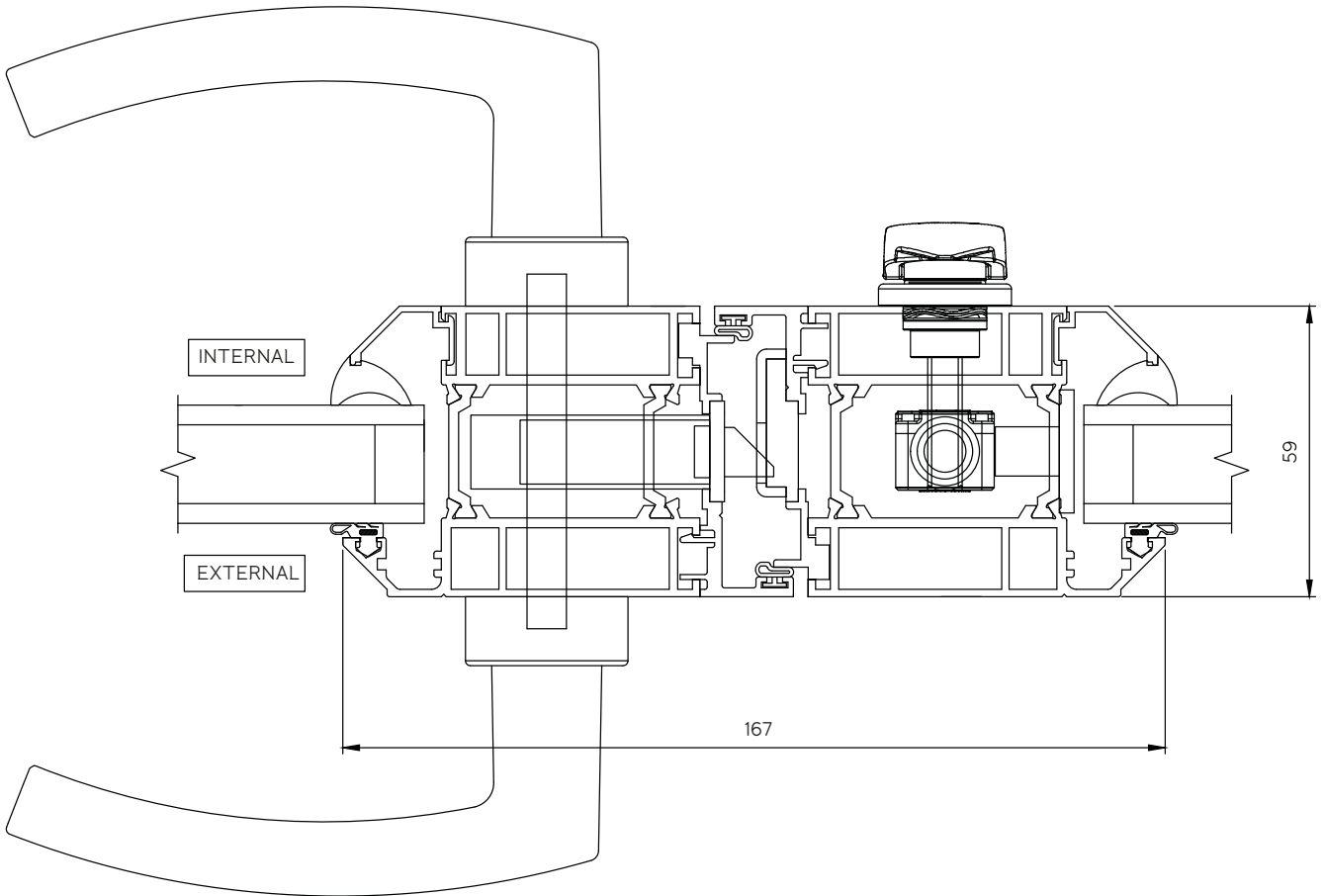

11 Keyed Locking Slave Detail

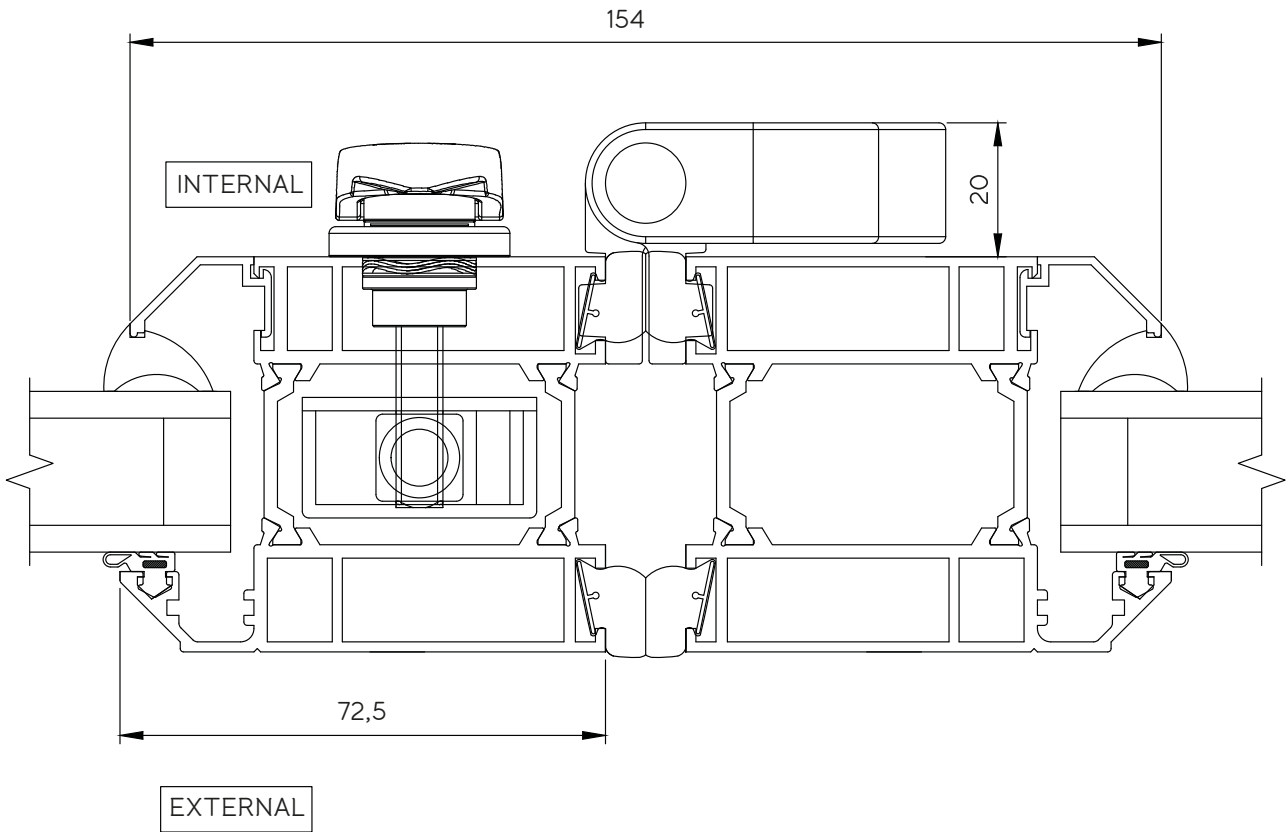

12 Fixed Door Concealed Locking

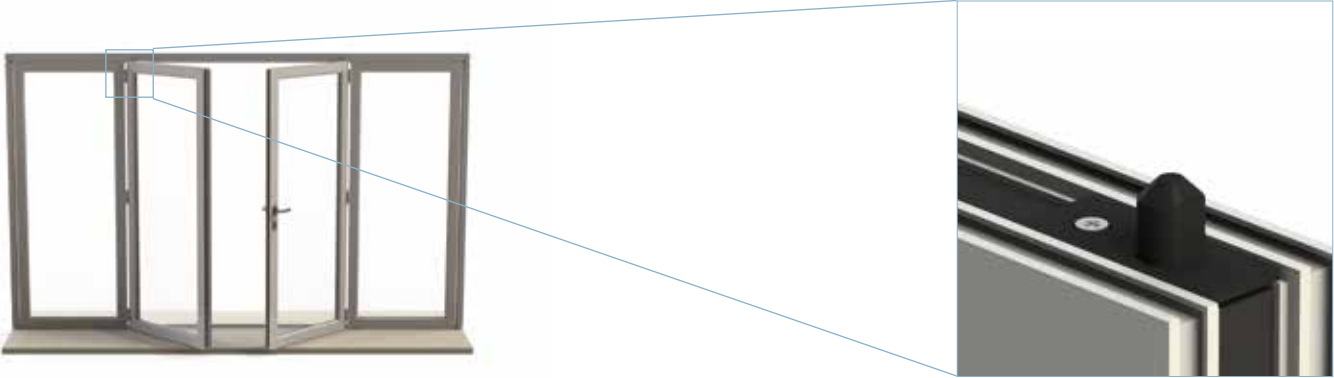
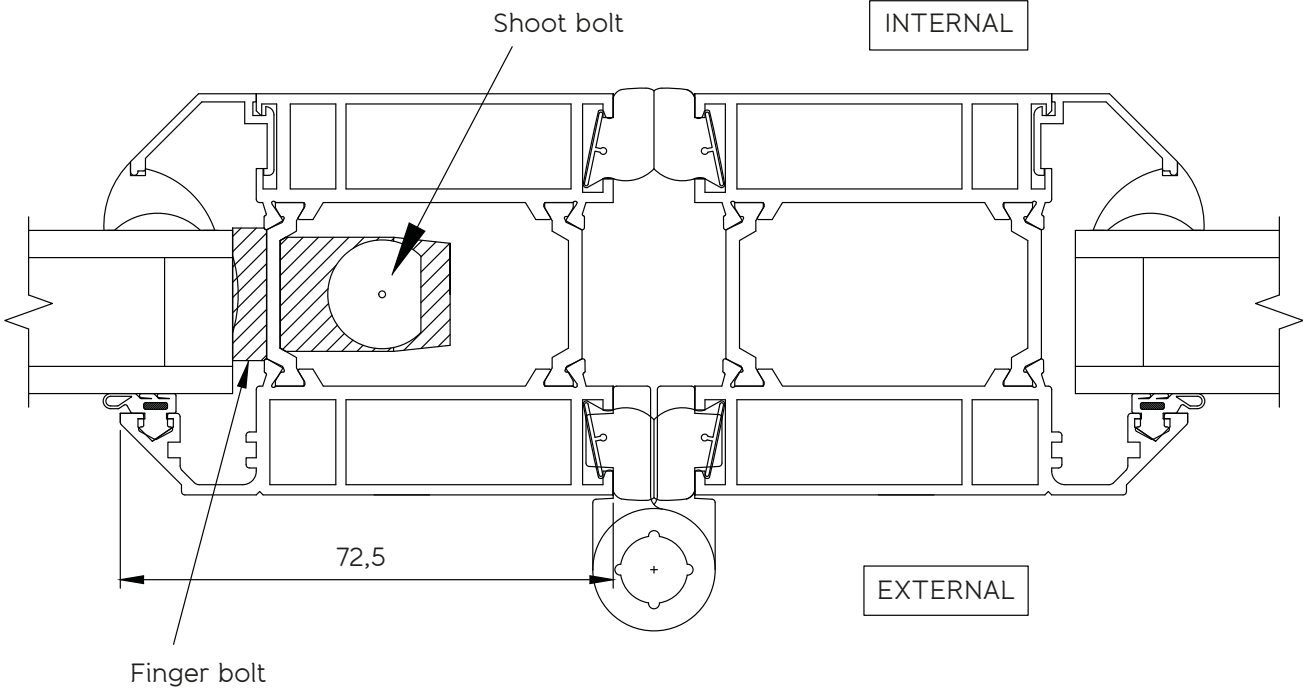

13 Locking Slave Handle Layout Detail

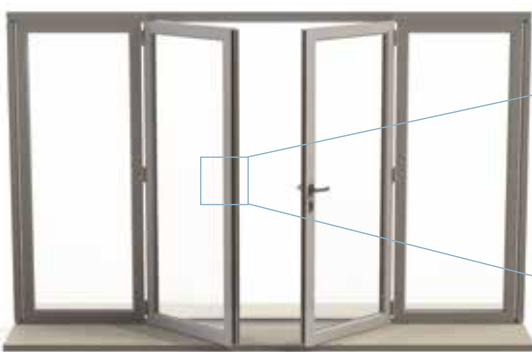
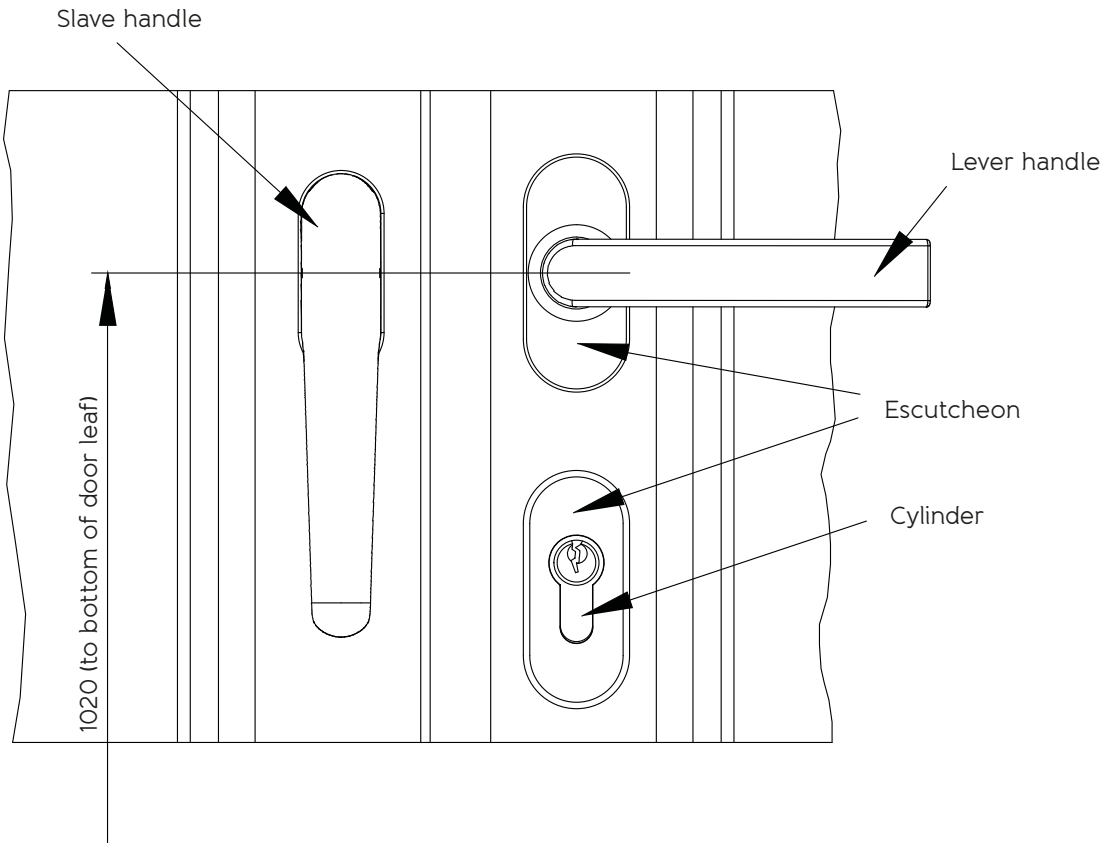

14 Keyed Locking Slave Layout Detail

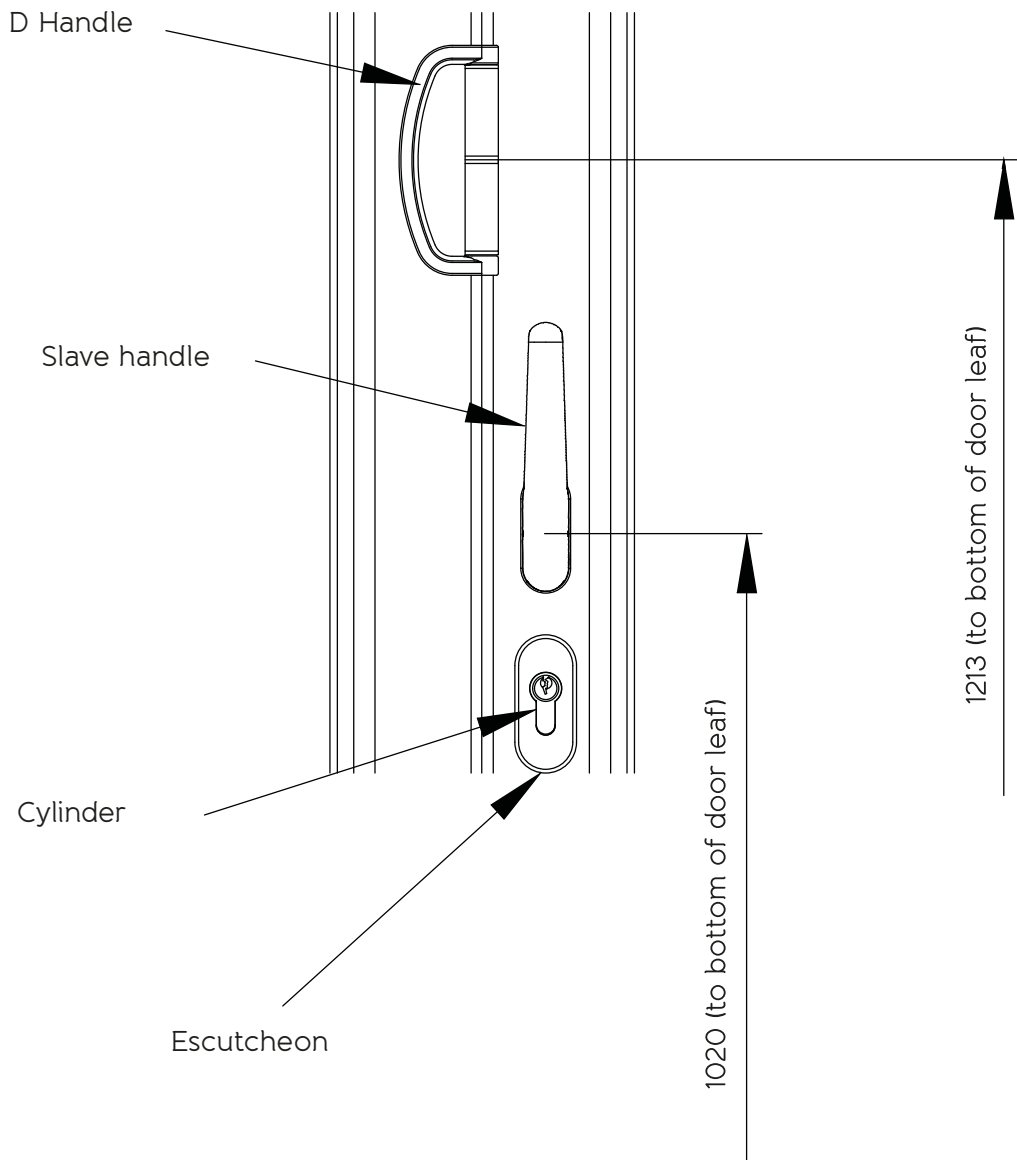

15

Cills

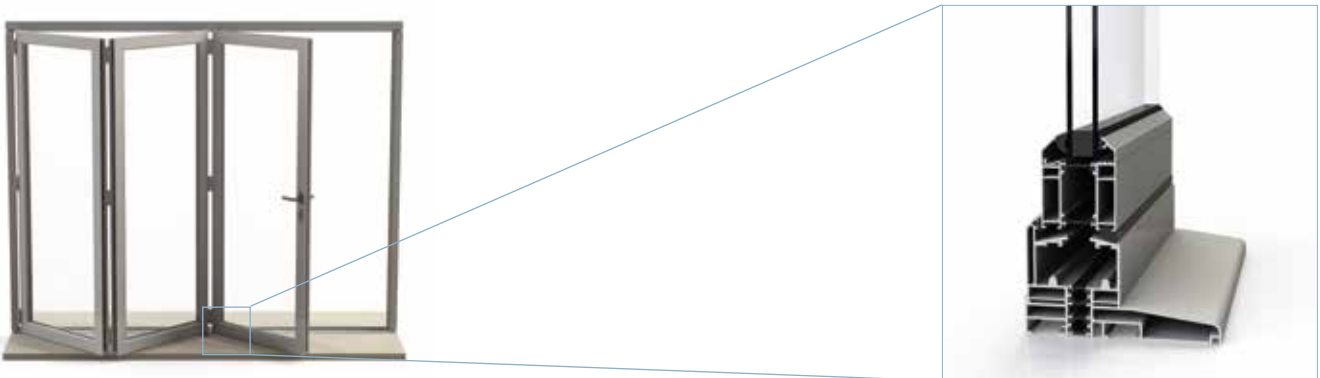
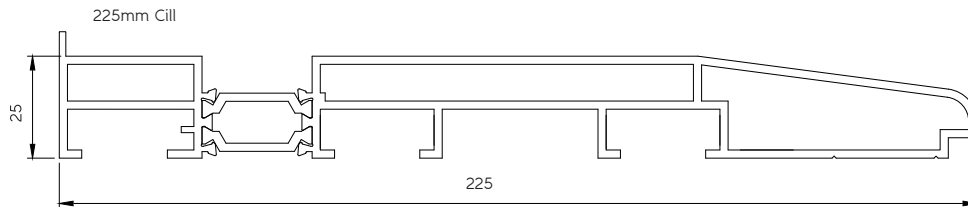
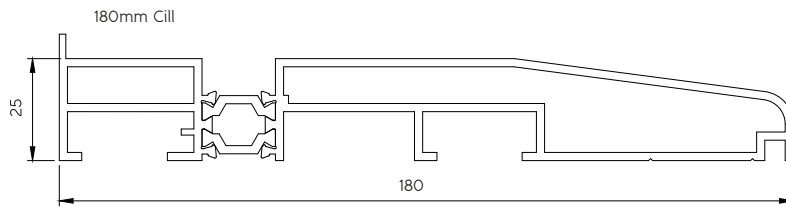
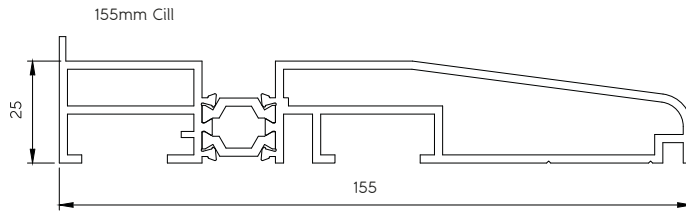
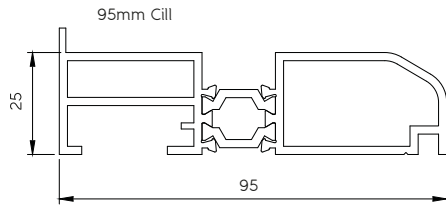

16 Locking Mullion Detail

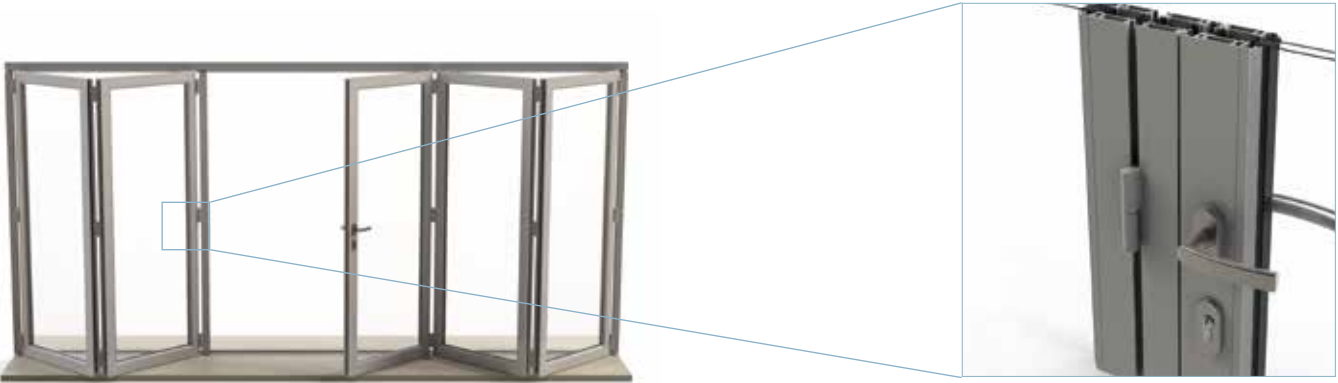
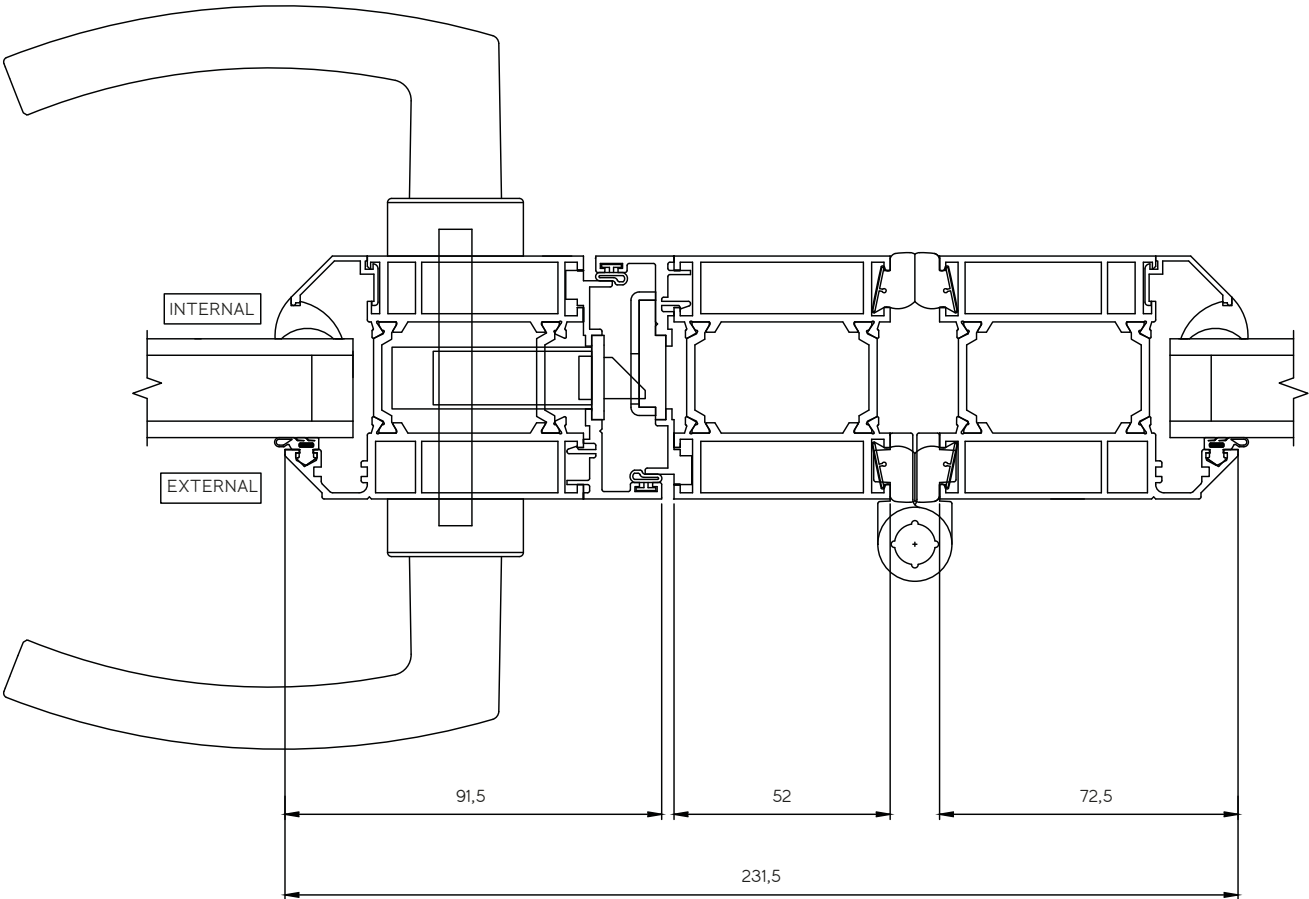

17 Standard Mullion Detail

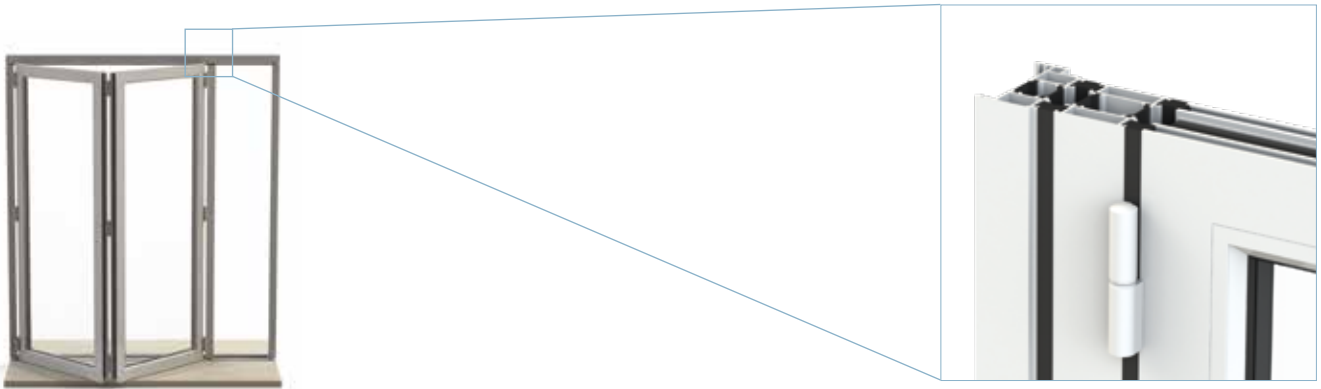
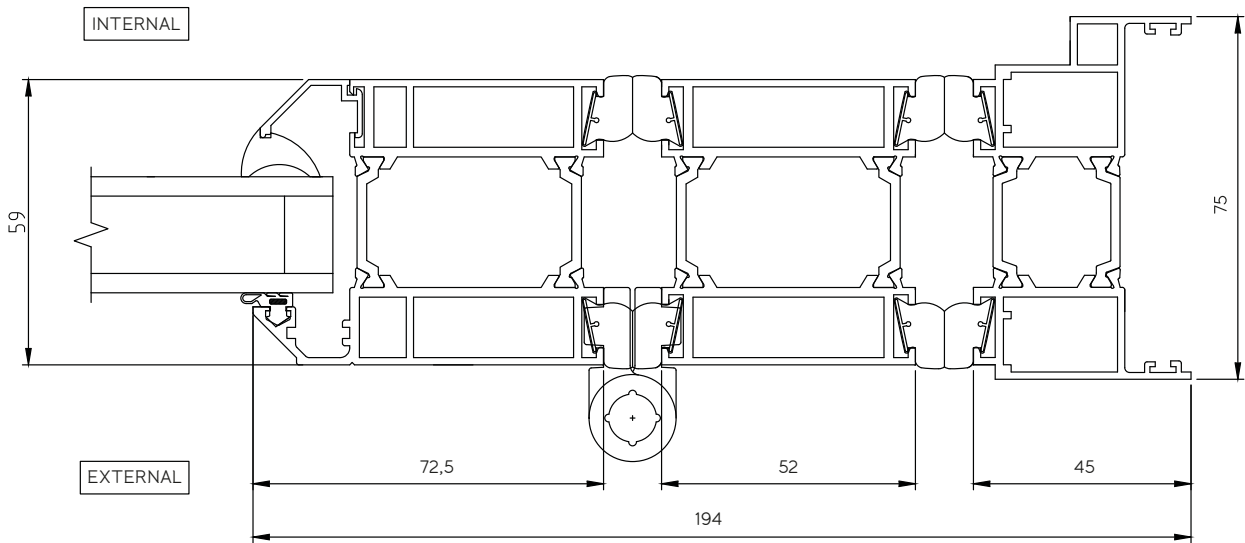

18 Midrail Detail

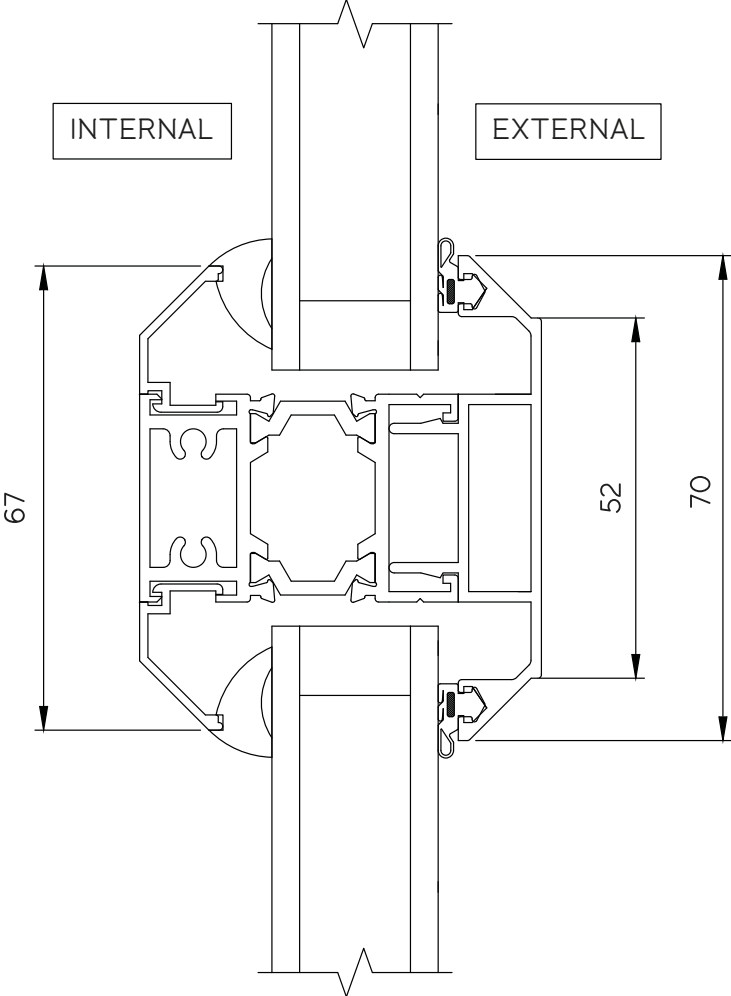

19 90° Moving Corner Post Detail

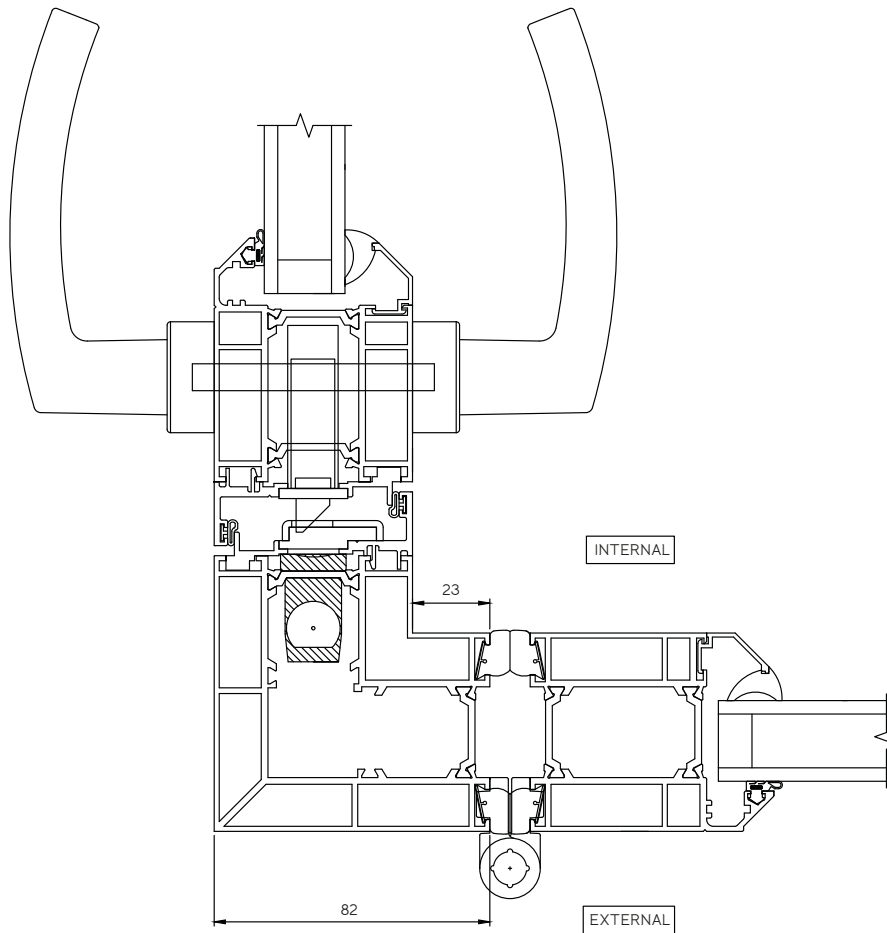

20 90° Fixed Corner Post Detail

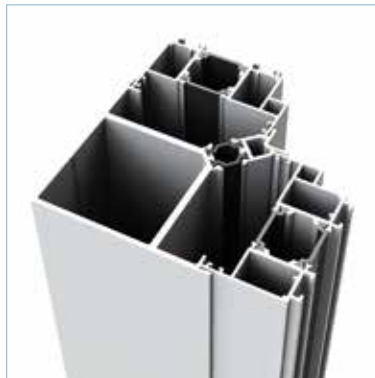
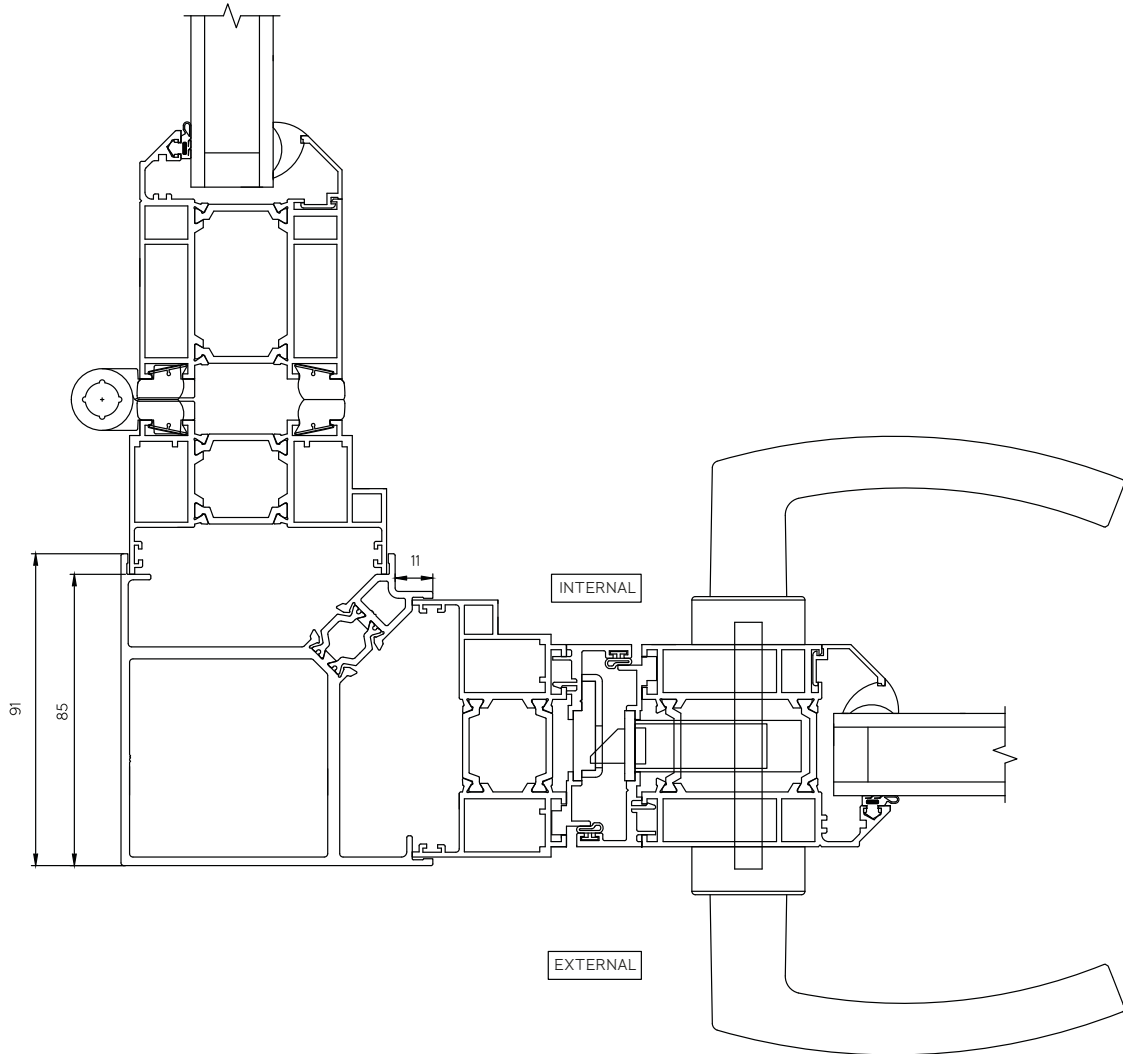

21 135° Moving Corner Post Detail

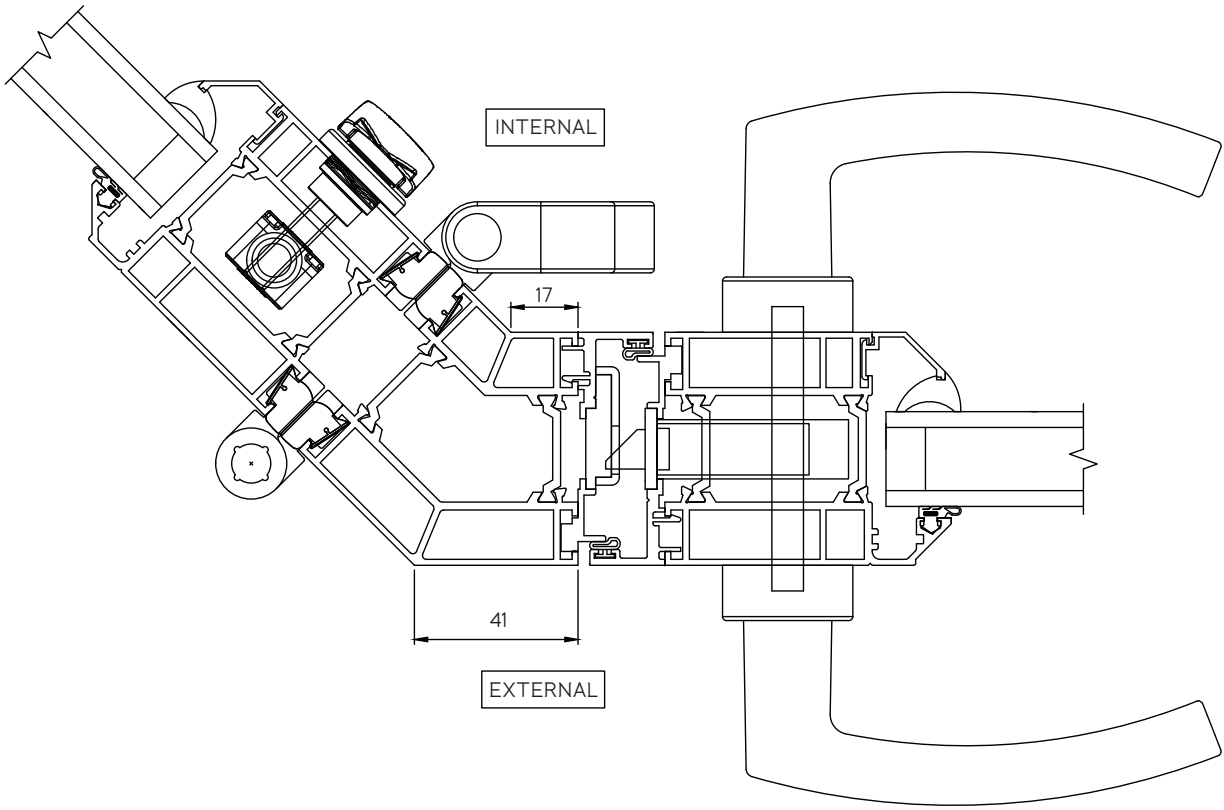

22 135° Fixed Corner Post Detail

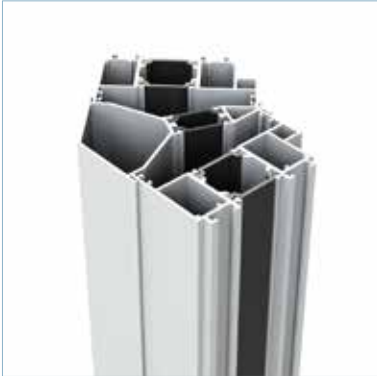
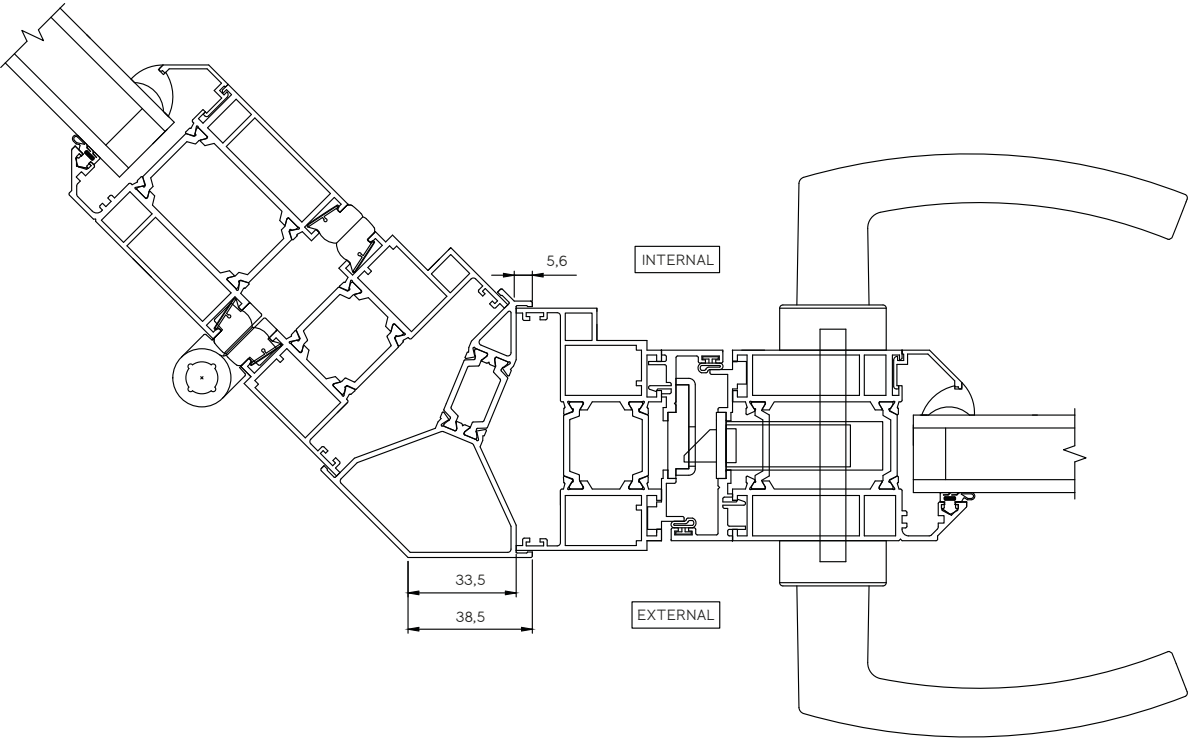

23a - 23b

Trickle Vents

20mm

25mm

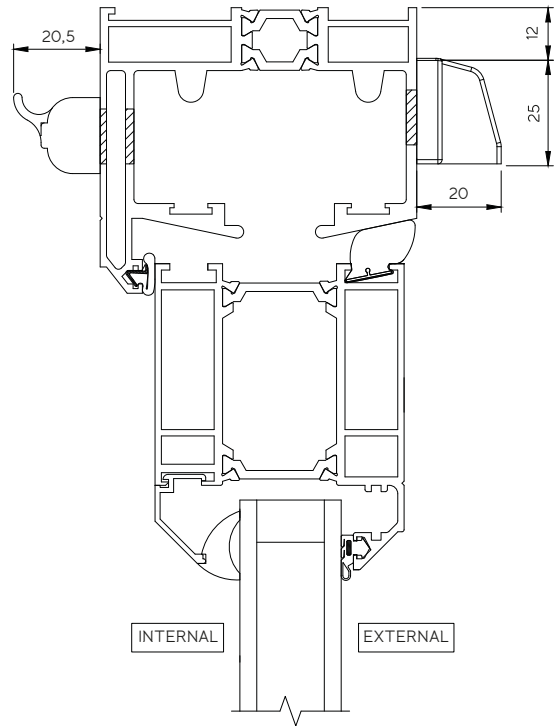
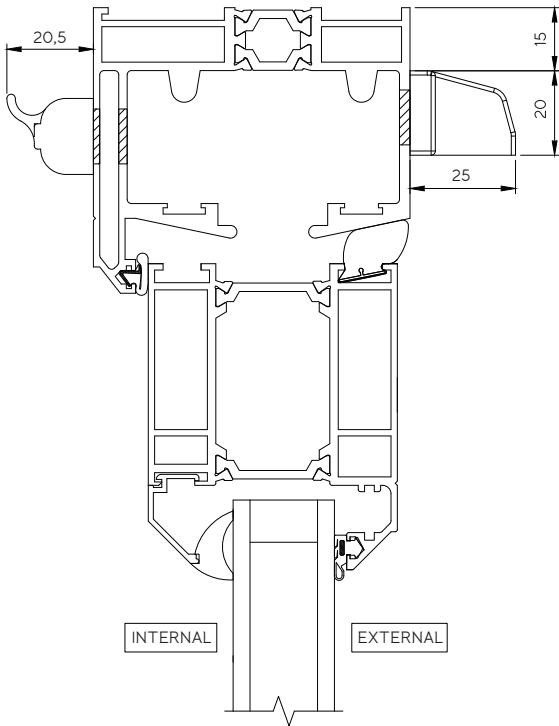

Internal view



External View

24a Bi-Fold Frame Extender Detail

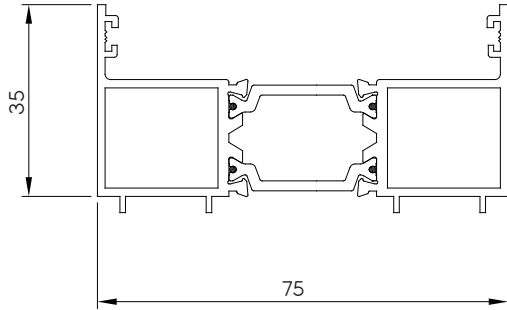

24b Bi-Fold Frame Extender On Top Track

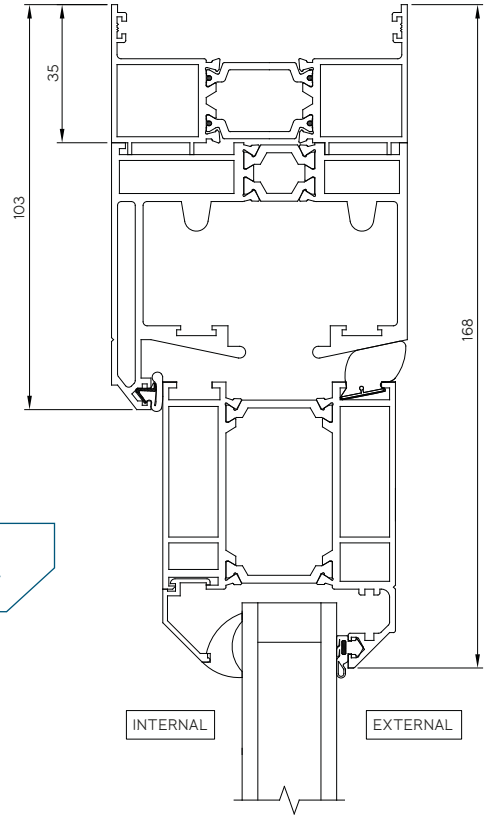

24c Bi-Fold Frame Extender With Trickle Vent

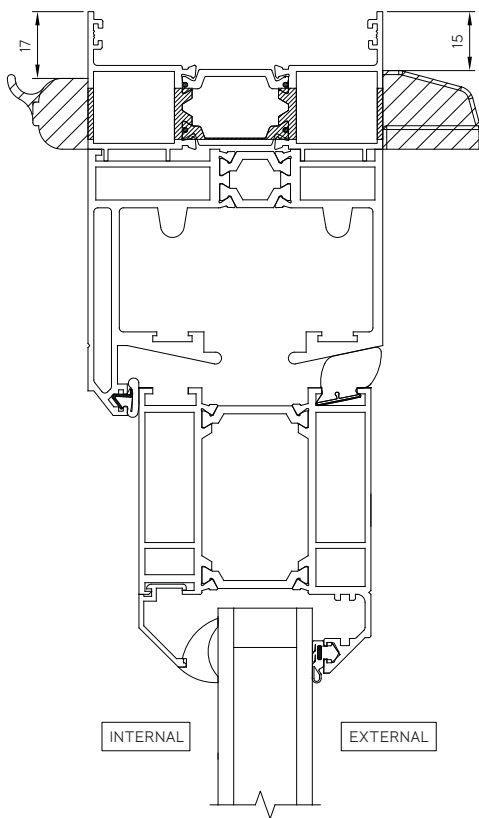

25 Door-to-Window Coupler Detail

See page 110 for install instructions.

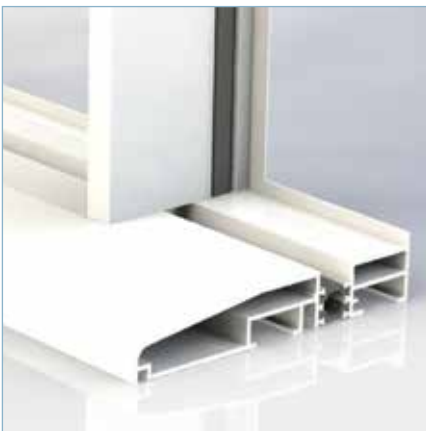
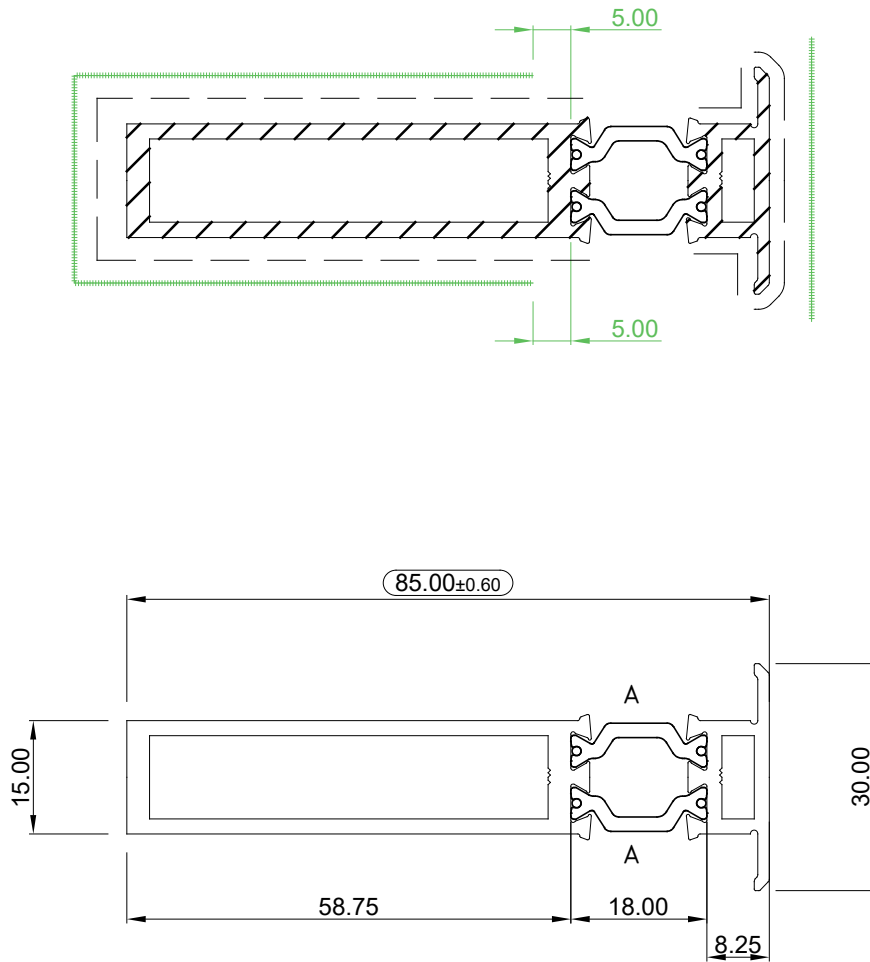

26 Trim Options

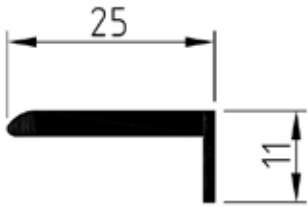

25mm trim

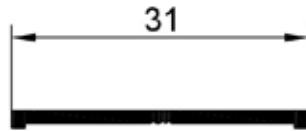

31mm flat trim

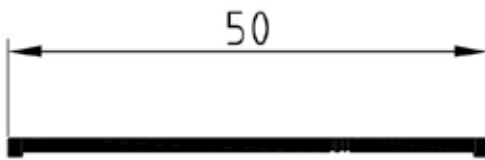

50mm flat trim

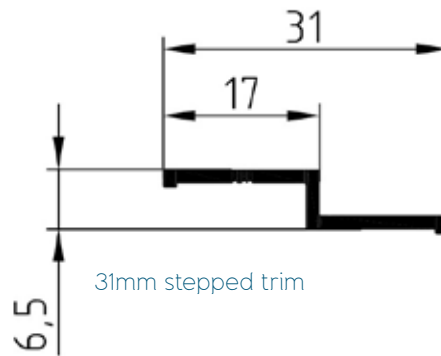

31mm stepped trim

27a 28mm Glazing Unit

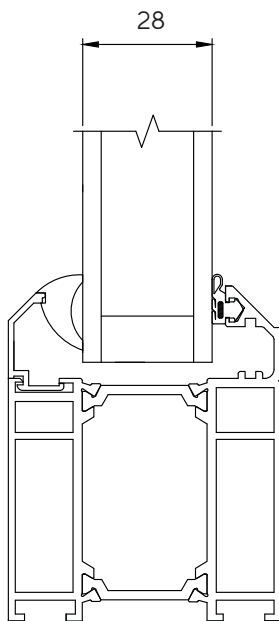

27b 28mm Glazing Unit

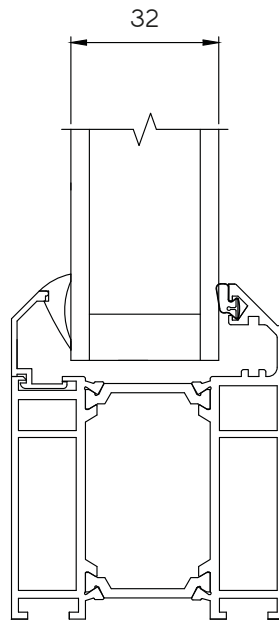

Handles

Hafi Handle 251/280

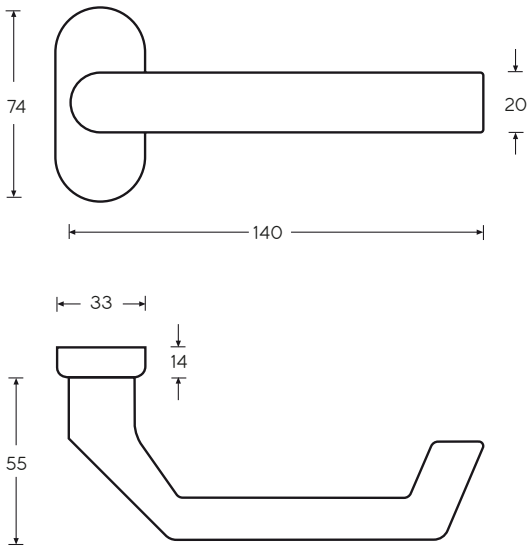

Hafi Handle 253/270

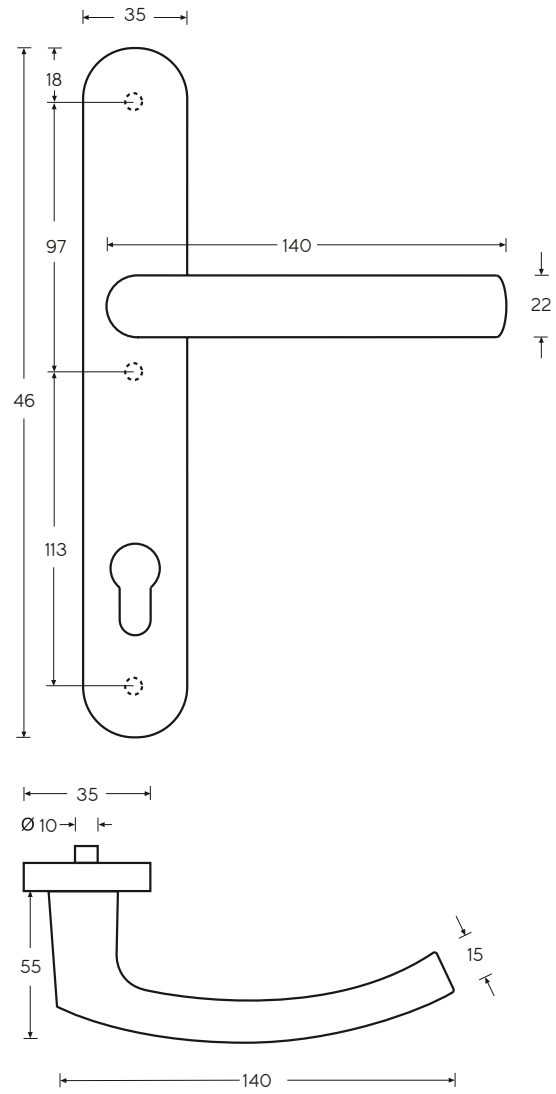

Handles

Hafi Handle 253/280

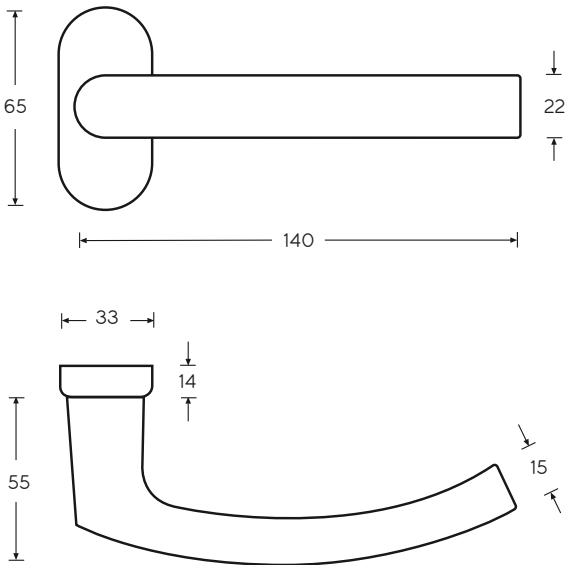

Hafi Handle 301/280

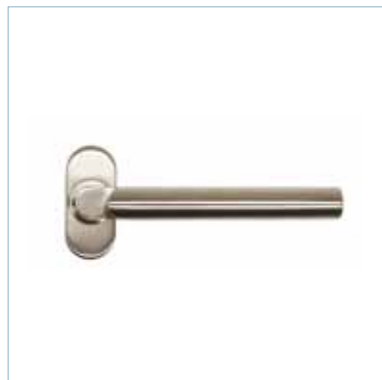
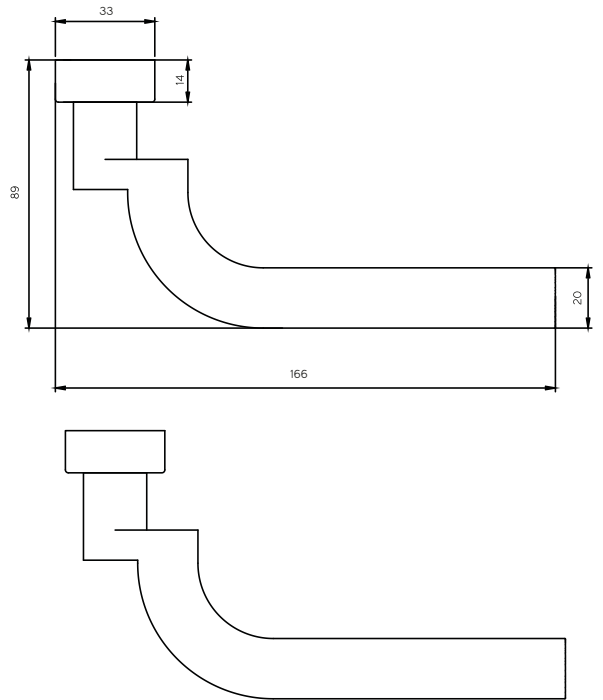

Handles

Hafi Handle 303/280

Hafi Handle Detail

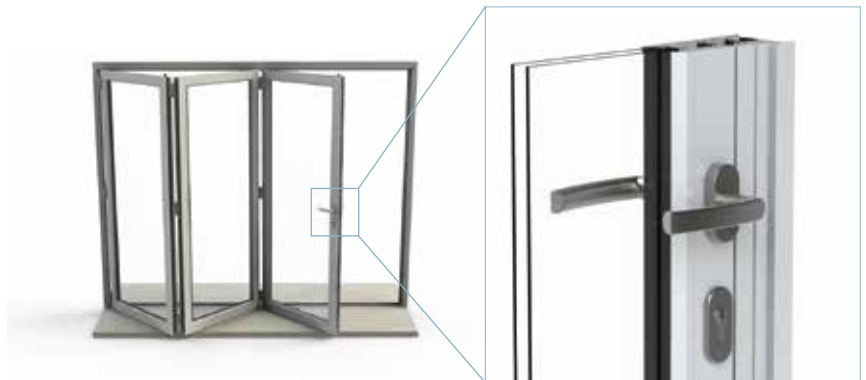
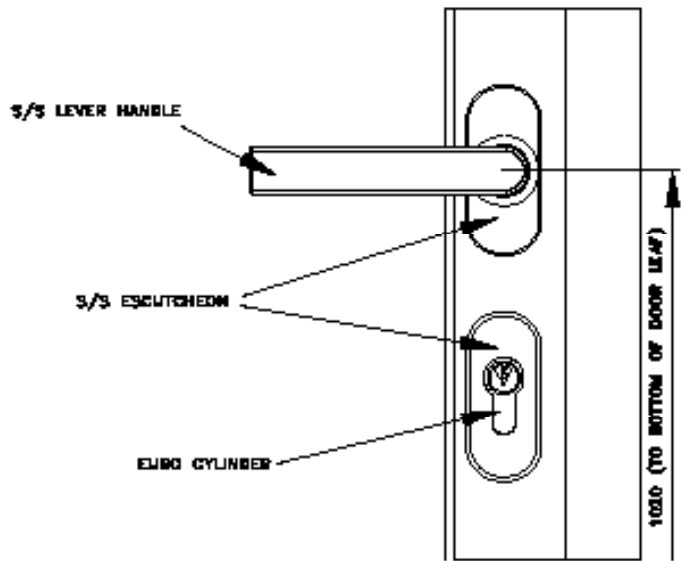
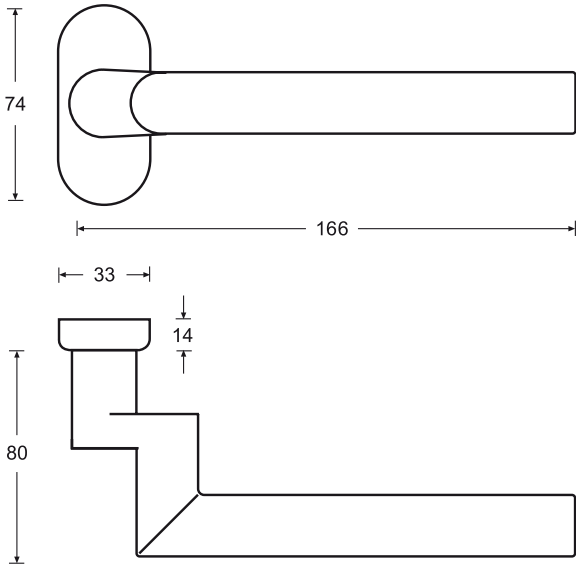

Aluminium Lever Handle

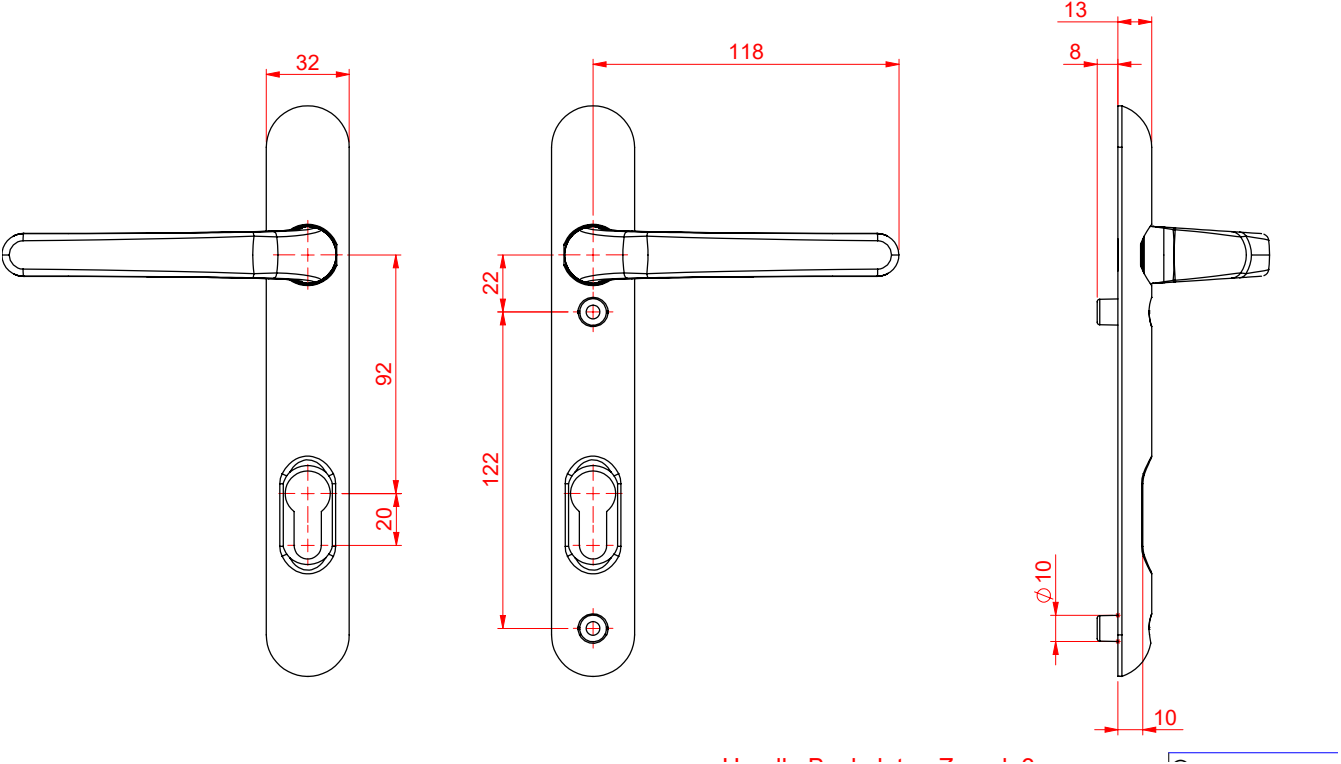

Available in 3 popular colours:
white, chrome and black



Handles

D-Handle

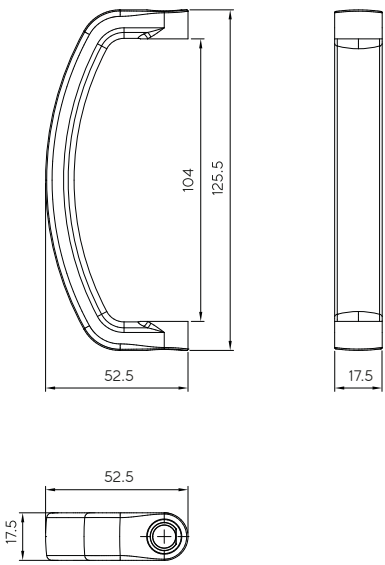

Slave Handle

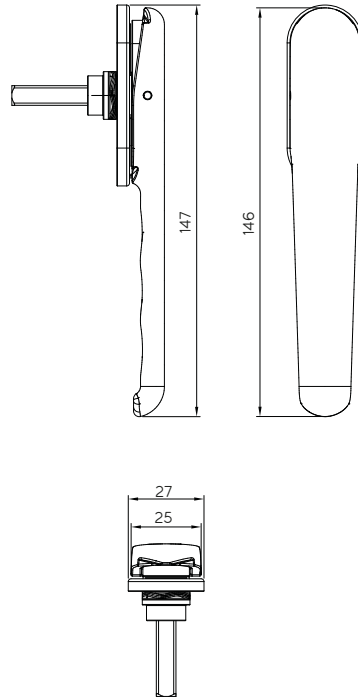

Slave and D-Handle Layout

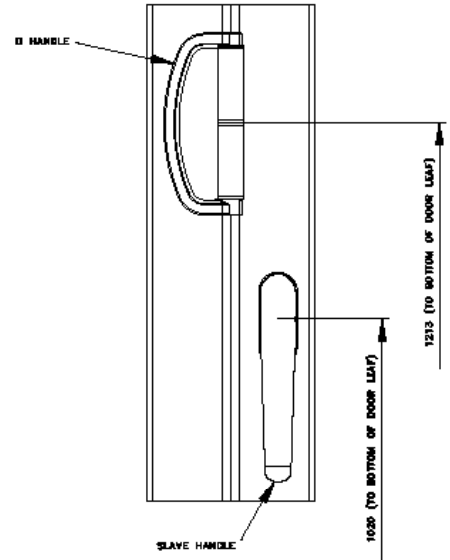

Gaskets

Double Glazing Gaskets 28mm

1. Glazing Rebate E3434

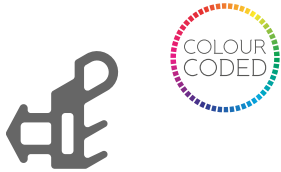

2. Glazing Wedge W474



3. Sash Side QL9135



4. Locking Rebate QL4636



5. Track Rebate QL9257



6. Sash Top and Bottom QL9141



Triple Glazing Gaskets 32mm

7. Glazing Rebate QL4627



8. Glazing Wedge W474



Colour	Glazing Rebate E-Gaskets	Glazing Wedge W474 28mm and 32mm	Sash Side QL9135 (2.5m)	Sash Side QL9135 (4m)	Locking Rebate QL4636	Track Rebate QL9257	Sash Top and Bottom QL9141	Glazing Rebate QL4627
Black	G00004	G00040	G00009	G00016	G00008	G00029	G00022	G00007
White	G00005	G00041	G00015	G00021		G00035	G00028	
Graphite Grey	G00066	G00061	G00012	G00018			G00025	
Anthracite Grey			G00100	G00111		G00099		
Light Oak	G00067	G00076	G00013	G00019		G00033	G00026	
Light Grey	G00071	G00075						
Bronze	G00072	G00077	G00010	G00052		G00030	G00023	
Chestnut Brown	G00073	G00078	G00011	G00017		G00031	G00024	
Slate Grey	G00074	G00068						
Silver Grey			G00014	G00020		G00034	G00027	

All Configurations

Code example

5+1 – OI – L
C **A** **B** **D**

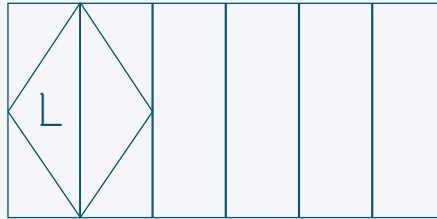

A The second number indicates where the lead/ access door is. As 1 is the second number, it means that is where the lead door is. If it had been 1+5, the last pane on the 5 door would be the lead door.

B OI = Open-in. OO = Open-out.

C The 5 is the number of doors folding the opposite way.

D L or R indicates which way the set with the lead door fold as viewed from outside.
 I.E - 5+1 – OI – L means the 1 door is folding to the left.

1 Door Configuration



0+1 – OO – L

Other variations: 1+0 – OI – L
 0+1 – OI – R
 0+1 – OO – R

2 Door Configurations



2+0 – OO – L

Other variations: 2+0 – OI – L
 2+0 – OI – R
 2+0 – OO – R



1+1 – OO – L

Other variations: 1+1 – OI – L
 1+1 – OI – R
 1+1 – OO – R

3 Door Configurations



3+0 – OO – L

Other variations: 3+0 – OI – L
 3+0 – OI – R
 3+0 – OO – R











2+1 – OO – L









Other variations: 2+1 – OI – L
 2+1 – OI – R
 2+1 – OO – R

All Configurations



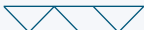









4 Door Configurations

	<p>IN </p> <p>OUT </p>	$4+0 - OO - L$	<p>Other variations: $4+0 - OI - L$ $4+0 - OI - R$ $4+0 - OO - R$</p>
	<p>IN </p> <p>OUT </p>	$3+1 - OO - L$	<p>Other variations: $3+1 - OI - L$ $3+1 - OI - R$ $3+1 - OO - R$</p>
	<p>IN </p> <p>OUT </p>	$1+3 - OO - L$	<p>Other variations: $1+3 - OI - L$ $1+3 - OI - R$ $1+3 - OO - R$</p>

5 Door Configurations







	<p>IN </p> <p>OUT </p>	$5+0 - OO - L$	<p>Other variations: $5+0 - OI - L$ $5+0 - OI - R$ $5+0 - OO - R$</p>
	<p>IN </p> <p>OUT </p>	$2+3 - OO - L$	<p>Other variations: $2+3 - OI - L$ $2+3 - OI - R$ $2+3 - OO - R$</p>
	<p>IN </p> <p>OUT </p>	$4+1 - OO - L$	<p>Other variations: $4+1 - OI - L$ $4+1 - OI - R$ $4+1 - OO - R$</p>

6 Door Configurations



	<p>IN </p> <p>OUT </p>	$6+0 - OO - L$	<p>Other variations: $6+0 - OI - L$ $6+0 - OI - R$ $6+0 - OO - R$</p>
	<p>IN </p> <p>OUT </p>	$5+1 - OO - L$	<p>Other variations: $5+1 - OI - L$ $5+1 - OI - R$ $5+1 - OO - R$</p>
	<p>IN </p> <p>OUT </p>	$1+5 - OO - L$	<p>Other variations: $1+5 - OI - L$ $1+5 - OI - R$ $1+5 - OO - R$</p>
	<p>IN </p> <p>OUT </p>	$3+3 - OO - L$	<p>Other variations: $3+3 - OI - L$ $3+3 - OI - R$ $3+3 - OO - R$</p>

All Configurations

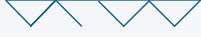
7 Door Configurations











	IN  OUT	$7+0 - \text{OO} - \text{L}$	Other variations: $7+0 - \text{OI} - \text{L}$ $7+0 - \text{OI} - \text{R}$ $7+0 - \text{OO} - \text{R}$
	IN  OUT	$6+1 - \text{OO} - \text{L}$	Other variations: $6+1 - \text{OI} - \text{L}$ $6+1 - \text{OI} - \text{R}$ $6+1 - \text{OO} - \text{R}$
	IN  OUT	$2+5 - \text{OO} - \text{L}$	Other variations: $2+5 - \text{OI} - \text{L}$ $2+5 - \text{OI} - \text{R}$ $2+5 - \text{OO} - \text{R}$
	IN  OUT	$4+3 - \text{OO} - \text{L}$	Other variations: $4+3 - \text{OI} - \text{L}$ $4+3 - \text{OI} - \text{R}$ $4+3 - \text{OO} - \text{R}$

8 Door Configurations









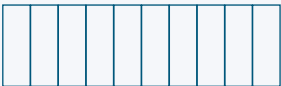

	IN  OUT	$8+0 - \text{OO} - \text{L}$	Other variations: $8+0 - \text{OI} - \text{L}$ $8+0 - \text{OI} - \text{R}$ $8+0 - \text{OO} - \text{R}$
	IN  OUT	$7+1 - \text{OO} - \text{L}$	Other variations: $7+1 - \text{OI} - \text{L}$ $7+1 - \text{OI} - \text{R}$ $7+1 - \text{OO} - \text{R}$
	IN  OUT	$1+7 - \text{OO} - \text{L}$	Other variations: $1+7 - \text{OI} - \text{L}$ $1+7 - \text{OI} - \text{R}$ $1+7 - \text{OO} - \text{R}$
	IN  OUT	$5+3 - \text{OO} - \text{L}$	Other variations: $5+3 - \text{OI} - \text{L}$ $5+3 - \text{OI} - \text{R}$ $5+3 - \text{OO} - \text{R}$
	IN  OUT	$3+5 - \text{OO} - \text{L}$	Other variations: $3+5 - \text{OI} - \text{L}$ $3+5 - \text{OI} - \text{R}$ $3+5 - \text{OO} - \text{R}$

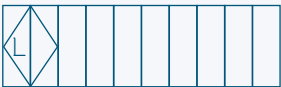
All Configurations

9 Door Configurations

	IN  OUT	9+0 – OO – L	Other variations: 9+0 – OI – L 9+0 – OI – R 9+0 – OO – R
	IN  OUT	8+1 – OO – L	Other variations: 8+1 – OI – L 8+1 – OI – R 8+1 – OO – R
	IN  OUT	2+7 – OO – L	Other variations: 2+7 – OI – L 2+7 – OI – R 2+7 – OO – R
	IN  OUT	6+3 – OO – L	Other variations: 6+3 – OI – L 6+3 – OI – R 6+3 – OO – R
	IN  OUT	4+5 – OO – L	Other variations: 4+5 – OI – L 4+5 – OI – R 4+5 – OO – R

10 Door Configurations

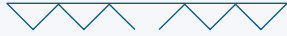
	IN  OUT	10+0 – OO – L	Other variations: 10+0 – OI – L 10+0 – OI – R 10+0 – OO – R
	IN  OUT	9+1 – OO – L	Other variations: 9+1 – OI – L 9+1 – OI – R 9+1 – OO – R
	IN  OUT	1+9 – OO – L	Other variations: 1+9 – OI – L 1+9 – OI – R 1+9 – OO – R
	IN  OUT	7+3 – OO – L	Other variations: 7+3 – OI – L 7+3 – OI – R 7+3 – OO – R
	IN  OUT	3+7 – OO – L	Other variations: 3+7 – OI – L 3+7 – OI – R 3+7 – OO – R
	IN  OUT	5+5 – OO – L	Other variations: 5+5 – OI – L 5+5 – OI – R 5+5 – OO – R

All Configurations

Corner Configurations

IC = Internal Corner EC = External Corner



1+1 - OO - L - EC

Other variations: OI - R - IC OI - R - EC
 1+1 - OO - R - EC 1+1 - OI - L - EC 1+1 - OO - L - IC 1+1 - OO - R - IC 1+1 - OI - L - IC



2+1 - OO - L - EC

Other variations: OI - R - IC OI - R - EC
 2+1 - OO - R - EC 2+1 - OI - L - EC 2+1 - OO - L - IC 2+1 - OO - R - IC 2+1 - OI - L - IC



1+3 - OO - L - EC

Other variations: OI - R - IC OI - R - EC
 1+3 - OO - R - EC 1+3 - OI - L - EC 1+3 - OO - L - IC 1+3 - OO - R - IC 1+3 - OI - L - IC



3+1 - OO - L - EC

Other variations: OI - R - IC OI - R - EC
 3+1 - OO - R - EC 3+1 - OI - L - EC 3+1 - OO - L - IC 3+1 - OO - R - IC 3+1 - OI - L - IC



4+1 - OO - L - EC

Other variations: OI - R - IC OI - R - EC
 4+1 - OO - R - EC 4+1 - OI - L - EC 4+1 - OO - L - IC 4+1 - OO - R - IC 4+1 - OI - L - IC

All Configurations



$3+2 - OO - L - EC$

Other variations: $OI - R - IC$ $OI - R - EC$
 $3+2 - OO - R - EC$ $3+2 - OI - L - EC$ $3+2 - OO - L - IC$ $3+2 - OO - R - IC$ $3+2 - OI - L - IC$

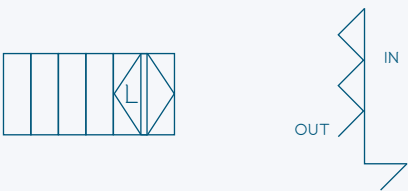

$1+5 - OO - L - EC$

Other variations: $OI - R - IC$ $OI - R - EC$
 $1+5 - OO - R - EC$ $1+5 - OI - L - EC$ $1+5 - OO - L - IC$ $1+5 - OO - R - IC$ $1+5 - OI - L - IC$



$3+3 - OO - L - EC$

Other variations: $OI - R - IC$ $OI - R - EC$
 $3+3 - OO - R - EC$ $3+3 - OI - L - EC$ $3+3 - OO - L - IC$ $3+3 - OO - R - IC$ $3+3 - OI - L - IC$

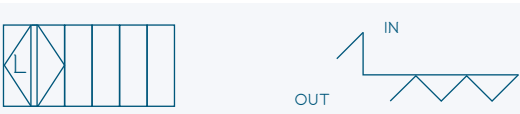

$5+1 - OO - L - EC$

Other variations: $OI - R - IC$ $OI - R - EC$
 $5+1 - OO - R - EC$ $5+1 - OI - L - EC$ $5+1 - OO - L - IC$ $5+1 - OO - R - IC$ $5+1 - OI - L - IC$



$6+1 - OO - L - EC$

Other variations: $OI - R - IC$ $OI - R - EC$
 $6+1 - OO - R - EC$ $6+1 - OI - L - EC$ $6+1 - OO - L - IC$ $6+1 - OO - R - IC$ $6+1 - OI - L - IC$

All Configurations

Corner Configurations



$2+5 - OO - L - EC$

Other variations: OI - R - IC OI - R - EC
 $2+5 - OO - R - EC$ $2+5 - OI - L - EC$ $2+5 - OO - L - IC$ $2+5 - OO - R - IC$ $2+5 - OI - L - IC$



$4+3 - OO - L - EC$

Other variations: OI - R - IC OI - R - EC
 $4+3 - OO - R - EC$ $4+3 - OI - L - EC$ $4+3 - OO - L - IC$ $4+3 - OO - R - IC$ $4+3 - OI - L - IC$



$1+7 - OO - L - EC$

Other variations: OI - R - IC OI - R - EC
 $1+7 - OO - R - EC$ $1+7 - OI - L - EC$ $1+7 - OO - L - IC$ $1+7 - OO - R - IC$ $1+7 - OI - L - IC$



$3+5 - OO - L - EC$

Other variations: OI - R - IC OI - R - EC
 $3+5 - OO - R - EC$ $3+5 - OI - L - EC$ $3+5 - OO - L - IC$ $3+5 - OO - R - IC$ $3+5 - OI - L - IC$

All Configurations

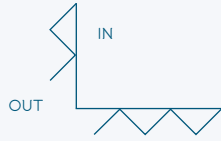
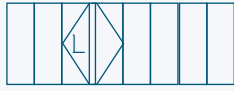

5+3 – OO – L – EC

Other variations: OI – R – IC OI – R – EC
 5+3 – OO – R – EC 5+3 – OI – L – EC 5+3 – OO – L – IC 5+3 – OO – R – IC 5+3 – OI – L – IC

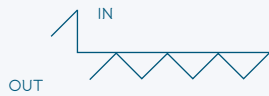

7+1 – OO – L – EC

Other variations: OI – R – IC OI – R – EC
 7+1 – OO – R – EC 7+1 – OI – L – EC 7+1 – OO – L – IC 7+1 – OO – R – IC 7+1 – OI – L – IC

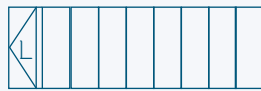

8+1 – OO – L – EC

Other variations: OI – R – IC OI – R – EC
 8+1 – OO – R – EC 8+1 – OI – L – EC 8+1 – OO – L – IC 8+1 – OO – R – IC 8+1 – OI – L – IC

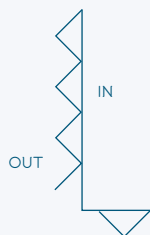

2+7 – OO – L – EC

Other variations: OI – R – IC OI – R – EC
 2+7 – OO – R – EC 2+7 – OI – L – EC 2+7 – OO – L – IC 2+7 – OO – R – IC 2+7 – OI – L – IC

All Configurations

Corner Configurations



$6+3 - OO - L - EC$

Other variations: $OI - R - IC$ $OI - R - EC$
 $6+3 - OO - R - EC$ $6+3 - OI - L - EC$ $6+3 - OO - L - IC$ $6+3 - OO - R - IC$ $6+3 - OI - L - IC$



$4+5 - OO - L - EC$

Other variations: $OI - R - IC$ $OI - R - EC$
 $4+5 - OO - R - EC$ $4+5 - OI - L - EC$ $4+5 - OO - L - IC$ $4+5 - OO - R - IC$ $4+5 - OI - L - IC$



$1+9 - OO - L - EC$

Other variations: $OI - R - IC$ $OI - R - EC$
 $1+9 - OO - R - EC$ $1+9 - OI - L - EC$ $1+9 - OO - L - IC$ $1+9 - OO - R - IC$ $1+9 - OI - L - IC$

All Configurations

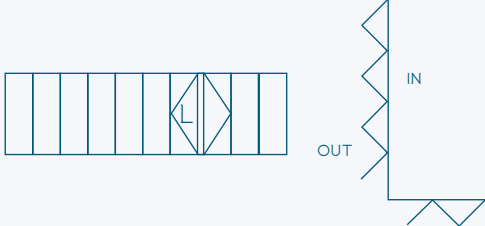

$3+7 - OO - L - EC$

Other variations: OI - R - IC OI - R - EC
 $3+7 - OO - R - EC$ $3+7 - OI - L - EC$ $3+7 - OO - L - IC$ $3+7 - OO - R - IC$ $3+7 - OI - L - IC$

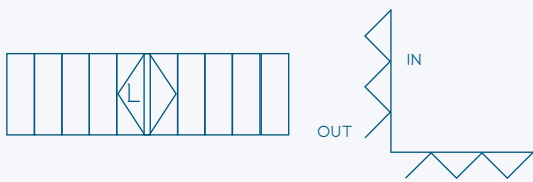

$5+5 - OO - L - EC$

Other variations: OI - R - IC OI - R - EC
 $5+5 - OO - R - EC$ $5+5 - OI - L - EC$ $5+5 - OO - L - IC$ $5+5 - OO - R - IC$ $5+5 - OI - L - IC$



$7+3 - OO - L - EC$

Other variations: OI - R - IC OI - R - EC
 $7+3 - OO - R - EC$ $7+3 - OI - L - EC$ $7+3 - OO - L - IC$ $7+3 - OO - R - IC$ $7+3 - OI - L - IC$



$9+1 - OO - L - EC$

Other variations: OI - R - IC OI - R - EC
 $9+1 - OO - R - EC$ $9+1 - OI - L - EC$ $9+1 - OO - L - IC$ $9+1 - OO - R - IC$ $9+1 - OI - L - IC$

All Configurations

Wrapping Corner Configurations

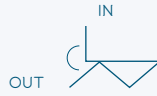

1+2 (0+3) – OO – R – EC

Other variations: OI – R – IC OI – R – EC
 1+2 – OO – L – EC 1+2 – OI – L – EC 1+2 – OO – L – IC 1+2 – OO – R – IC 1+2 – OI – L – IC

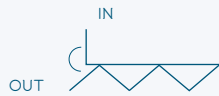

1+4 (0+5) – OO – R – EC

Other variations: OI – R – IC OI – R – EC
 1+4 – OO – L – EC 1+4 – OI – L – EC 1+4 – OO – L – IC 1+4 – OO – R – IC 1+4 – OI – L – IC



1+6 (0+7) – OO – R – EC

Other variations: OI – R – IC OI – R – EC
 1+6 – OO – L – EC 1+6 – OI – L – EC 1+6 – OO – L – IC 1+6 – OO – R – IC 1+6 – OI – L – IC



1+8 (0+9) – OO – R – EC

Other variations: OI – R – IC OI – R – EC
 1+8 – OO – L – EC 1+8 – OI – L – EC 1+8 – OO – L – IC 1+8 – OO – R – IC 1+8 – OI – L – IC

All Configurations



2+2 (1+3) – OO – R – EC

Other variations:

OI – R – IC

OI – R – EC

2+2 – OO – L – EC

2+2 – OI – L – EC

2+2 – OO – L – IC

2+2 – OO – R – IC

2+2 – OI – L – IC

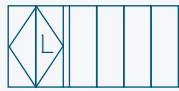

2+4 (1+5) – OO – R – EC

Other variations:

OI – R – IC

OI – R – EC

2+4 – OO – L – EC

2+4 – OI – L – EC

2+4 – OO – L – IC

2+4 – OO – R – IC

2+4 – OI – L – IC

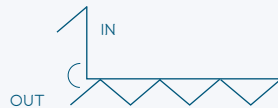
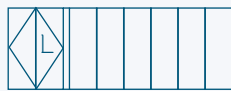

2+6 (1+7) – OO – R – EC

Other variations:

OI – R – IC

OI – R – EC

2+6 – OO – L – EC

2+6 – OI – L – EC

2+6 – OO – L – IC

2+6 – OO – R – IC

2+6 – OI – L – IC

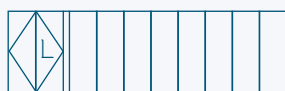

2+8 (1+9) – OO – R – EC

Other variations:

OI – R – IC

OI – R – EC

2+8 – OO – L – EC

2+8 – OI – L – EC

2+8 – OO – L – IC

2+8 – OO – R – IC

2+8 – OI – L – IC

All Configurations

Wrapping Corner Configurations

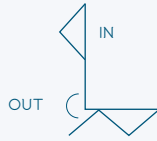

3+2 (2+3) – OO – R – EC

Other variations: OI – R – IC OI – R – EC
 3+2 – OO – L – EC 3+2 – OI – L – EC 3+2 – OO – L – IC 3+2 – OO – R – IC 3+2 – OI – L – IC

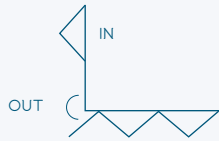

3+4 (2+5) – OO – R – EC

Other variations: OI – R – IC OI – R – EC
 3+4 – OO – L – EC 3+4 – OI – L – EC 3+4 – OO – L – IC 3+4 – OO – R – IC 3+4 – OI – L – IC

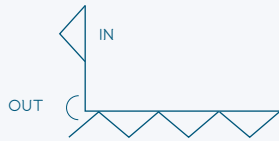

3+6 (2+7) – OO – R – EC

Other variations: OI – R – IC OI – R – EC
 3+6 – OO – L – EC 3+6 – OI – L – EC 3+6 – OO – L – IC 3+6 – OO – R – IC 3+6 – OI – L – IC

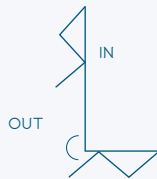

4+2 (3+3) – OO – R – EC

Other variations: OI – R – IC OI – R – EC
 4+2 – OO – L – EC 4+2 – OI – L – EC 4+2 – OO – L – IC 4+2 – OO – R – IC 4+2 – OI – L – IC

All Configurations

$4+4 (3+5) - OO - R - EC$

Other variations: $OI - R - IC$ $OI - R - EC$
 $4+4 - OO - L - EC$ $4+4 - OI - L - EC$ $4+4 - OO - L - IC$ $4+4 - OO - R - IC$ $4+4 - OI - L - IC$

$4+6 (3+7) - OO - R - EC$

Other variations: $OI - R - IC$ $OI - R - EC$
 $4+4 - OO - L - EC$ $4+4 - OI - L - EC$ $4+4 - OO - L - IC$ $4+4 - OO - R - IC$ $4+4 - OI - L - IC$

$5+2 (4+3) - OO - R - EC$

Other variations: $OI - R - IC$ $OI - R - EC$
 $5+2 - OO - L - EC$ $5+2 - OI - L - EC$ $5+2 - OO - L - IC$ $5+2 - OO - R - IC$ $5+2 - OI - L - IC$

$5+4 (4+5) - OO - R - EC$

Other variations: $OI - R - IC$ $OI - R - EC$
 $5+4 - OO - L - EC$ $5+4 - OI - L - EC$ $5+4 - OO - L - IC$ $5+4 - OO - R - IC$ $5+4 - OI - L - IC$

All Configurations

Wrapping Corner Configurations

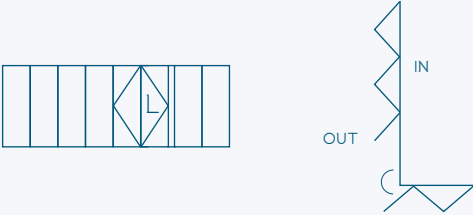

$6+2 (5+3) - OO - R - EC$

Other variations: $OI - R - IC$ $OI - R - EC$
 $6+2 - OO - L - EC$ $6+2 - OI - L - EC$ $6+2 - OO - L - IC$ $6+2 - OO - R - IC$ $6+2 - OI - L - IC$

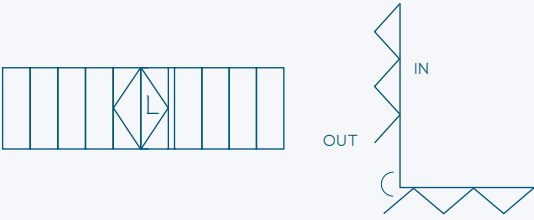

$6+4 (5+5) - OO - R - EC$

Other variations: $OI - R - IC$ $OI - R - EC$
 $6+4 - OO - L - EC$ $6+4 - OI - L - EC$ $6+4 - OO - L - IC$ $6+4 - OO - R - IC$ $6+4 - OI - L - IC$

All Configurations

$7+2 (6+3) - OO - R - EC$

Other variations: $OI - R - IC$ $OI - R - EC$
 $7+2 - OO - L - EC$ $7+2 - OI - L - EC$ $7+2 - OO - L - IC$ $7+2 - OO - R - IC$ $7+2 - OI - L - IC$

$8+2 (7+3) - OO - R - EC$

Other variations: $OI - R - IC$ $OI - R - EC$
 $8+2 - OO - L - EC$ $8+2 - OI - L - EC$ $8+2 - OO - L - IC$ $8+2 - OO - R - IC$ $8+2 - OI - L - IC$

OB-72 Installation Guide

Components box

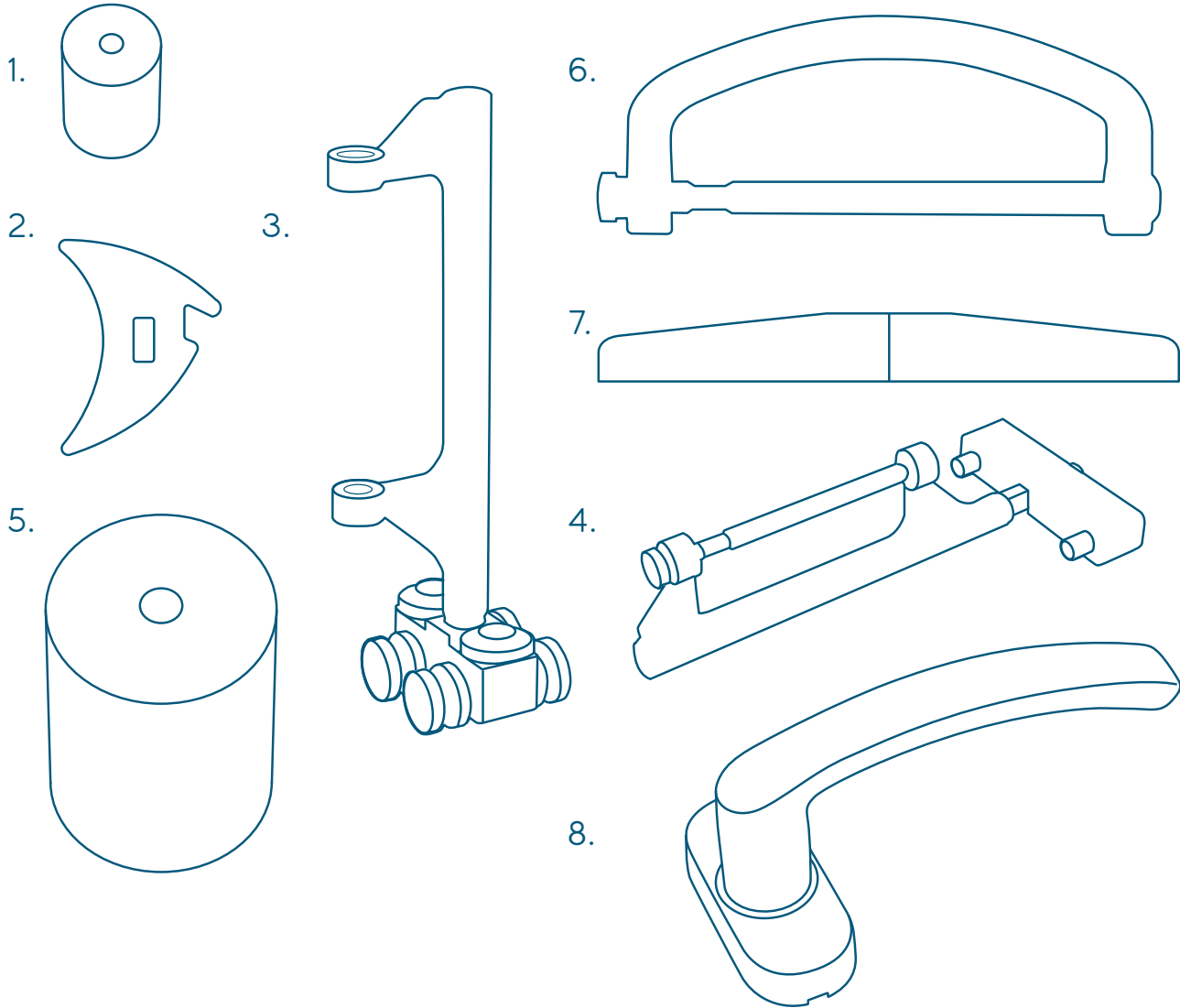

Contents

- | | | |
|---------------------|---|---|
| ▶ 1. Fixing plugs | ▶ 4. Top trolley | ▶ 6. D-handle |
| ▶ 2. Wedge gasket | ▶ 5. Magnetic keep
(x 2 if door height is greater than 2499mm) | ▶ 7. Cill end cap |
| ▶ 3. Bottom trolley | ▶ 6. D-handle | ▶ 8. Long back plate lever/lever handle |

1. Tools list

1.1. Fixing kit to install up to 8 door leaves, including a selection of packers 1mm-6mm, 35 4mm x 40mm glazing packers and screws.

- ▶ 25mm self-tapping screws
- ▶ Appropriate fixings for lintel
- ▶ Mixed selection of frame packers
- ▶ 4mm glazing packers (min 32mm wide)
- ▶ Appropriate drill bits for drilling lintel and jamb packers
- ▶ 13mm HSS or blade type drill bit
- ▶ Long series 3.5mm drill bit
- ▶ SDS drill with appropriate size drill bits for your preferred frame fixings
- ▶ Battery screwdriver
- ▶ Saw for cutting aluminium cill
- ▶ Long straight edge
- ▶ Long spirit level
- ▶ String line
- ▶ Measuring staff
- ▶ Phillips 2, Pozi 2 and large flat head screw drivers
- ▶ 4mm Allen key
- ▶ 2.5mm Allen key
- ▶ 3mm Allen key
- ▶ Flat bar
- ▶ Plastic/ rubber hammer
- ▶ Glazing paddle
- ▶ Gasket sheers
- ▶ Foam gun
- ▶ Sealant and gun
- ▶ T30 torx key / small 1/4 ratchet with T30 bit

Note

If it is necessary to pack the outer frame by more than 6mm, a solid plastic or hardwood packer should be used.

2. Preparation

- ▶ **2.1.** Measure the opening and check it fits with all measurements on your Origin paperwork.
- ▶ **2.2.** Carefully unpack the tracks and jambs.
- ▶ **2.3.** On the hinge jamb, place a jamb packer level with each hinge. Position the jamb packers within 150mm of corner and 600mm apart on centre.

Repeat this for locking jamb.

- ▶ **2.4** On the locking jamb, place a jamb packer 50mm down and 50mm up from the top and bottom of the jamb.
- ▶ **2.5.** Secure jamb packers by inserting a screw either side, see FIG 2A.
- ▶ **2.6.** Spaced at a maximum of 500mm apart, place the correct frame packers along the length of the opening, creating a level, well supported platform for the track/cill to sit.

FIG 2A

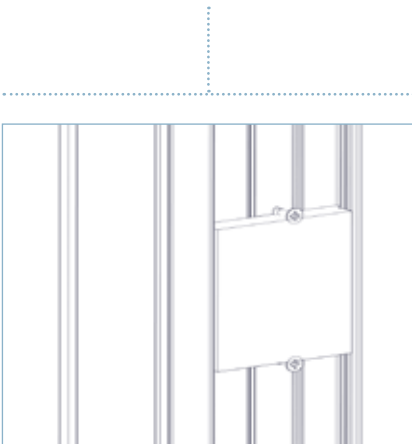
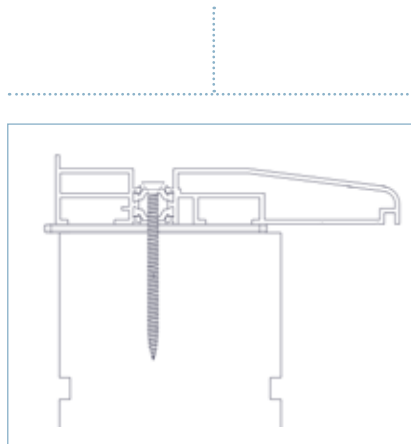

FIG 3A



3. Cill (if no cill, move to step 4.)

- ▶ **3.1.** Cut the cill to the correct length to fit the opening with or without horns.
- ▶ **3.2.** Using an appropriate sealant, fill the ends of the cill section and install the end caps.
- ▶ **3.3.** Place the cill on the prepared frame packers in the opening.
- ▶ **3.4.** Recheck for level, adjust if necessary.

NOTE: Move on to step 4 if the width is under 3600mm.

- ▶ **3.5.** Using a string line, make sure the cill does not have a bow.
- ▶ **3.6.** Fix the cill through the thermal break every 1000mm (shown in FIG 3A) using your preferred fixings. Fill each hole with suitable sealant before inserting the fixing.
- ▶ **3.7.** Recheck for level, adjust if necessary.

Note

The cill should be positioned with the back edge overhanging the building cavity; the distance specified by the local authority building regulations.

4. Outer frame

- ▶ **4.1.** Joining tracks (if applicable).
- ▶ **4.1.1.** All joints in the track are pre-made in the factory and separated for transport. When joints are pre-made, use a suitable clear sealant to seal the joint.
- ▶ **4.2.** Carefully remove the gasket from each end of the top and bottom track by approximately 200mm.
- ▶ **4.3.** Where possible, lay out the tracks and jambs in the correct positions with all labels facing up, being careful not to scratch the powder coat.
- ▶ **4.4.** Position the jambs into the tracks using the connectors provided as shown in FIG 4A.

NOTE: For mobility thresholds, after completing step 4.4, secure the jambs to the threshold using two of the supplied 3.5mm screws. Seal the mating faces with a suitable sealant.

- ▶ **4.5.** Using a rubber mallet, gently tap the jambs in to the track as shown in FIG 4B.

NOTE: If more than a tap is needed, the connectors are not aligned with the tracks.

- ▶ **4.6.** If applicable, using a suitable sealant, seal along the two ends and back lip of the cill where the bottom track will sit.
- ▶ **4.7.** Install the outer frame and insert frame packers above the top track at each end, compressing tracks, jambs and cill (if fitted), together closing all unwanted gaps and temporarily holding the frame in position as shown in FIG 4C.
- ▶ **4.8.** Make sure the bottom track is pushed up against the lip at the back of the cill (if fitted) and is central in the opening.

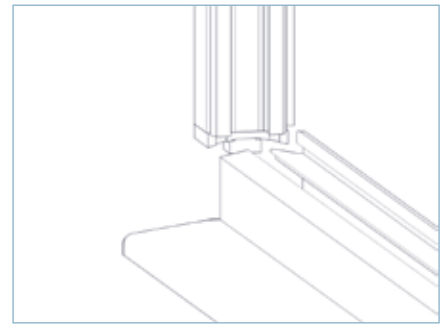

FIG 4A

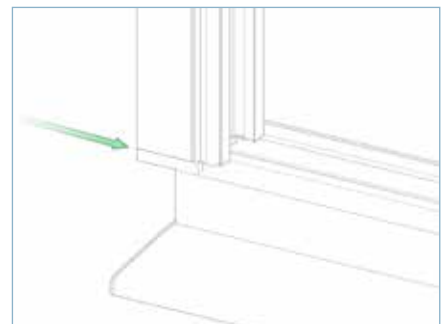

FIG 4B

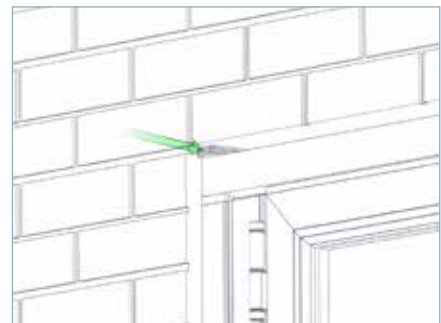

FIG 4C

5. Fixing the outer frame

▶ **5.1.** Fix the bottom track and cill as shown in FIG 5A. Position the fixings approximately 100mm in from each end of the track and one fixing every door width along the length. If there is no cill, fix the bottom track to the brick/ block below, making sure it is straight and remains level

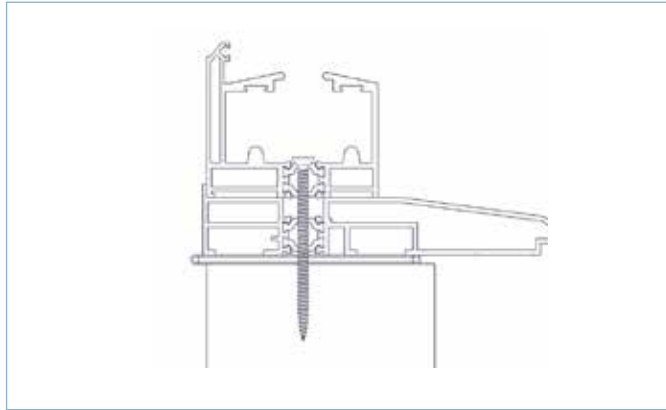

FIG 5A

▶ **5.2.** Using a 13mm drill bit, make a hole in the outer layer of polyamide, level with the centre of each jamb packer. This will allow installation of the fixing plug as shown in FIG 5B.

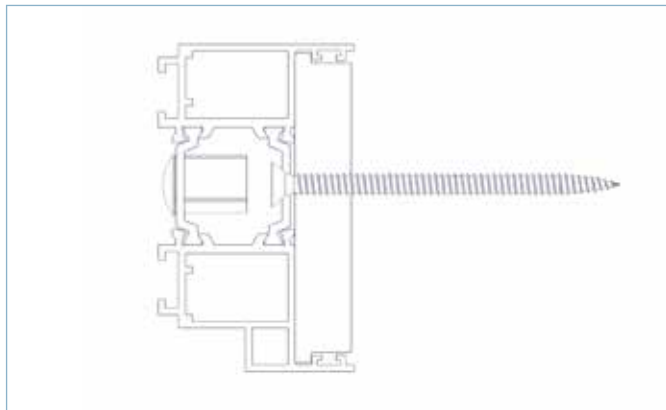

FIG 5B

▶ **5.3.** Using the correct size HSS bit for your preferred fixing, drill through each jamb packer. To protect your drill bit, place a putty knife (or similar) between the jamb packer and brick.

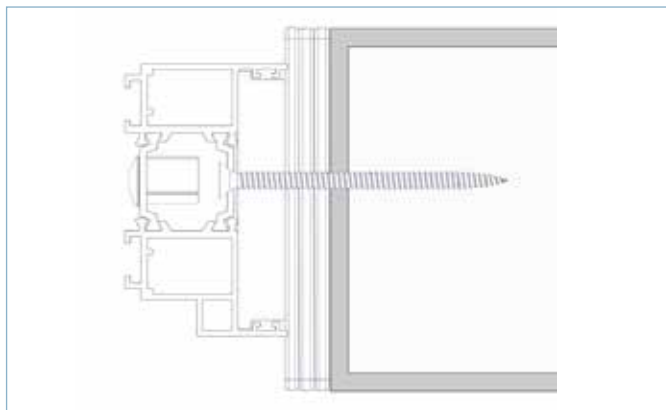

FIG 5C

▶ **5.4.** Align the bottom of the jambs with the end of the bottom track. Using frame packers between the jamb packers and the wall, level out the jambs in all directions and fix into position with your preferred fixings as shown in FIG 5C.

5. Fixing the outer frame continued

▶ **5.5.** Align the end of the top track with the top of the jamb as shown in FIG 5D.

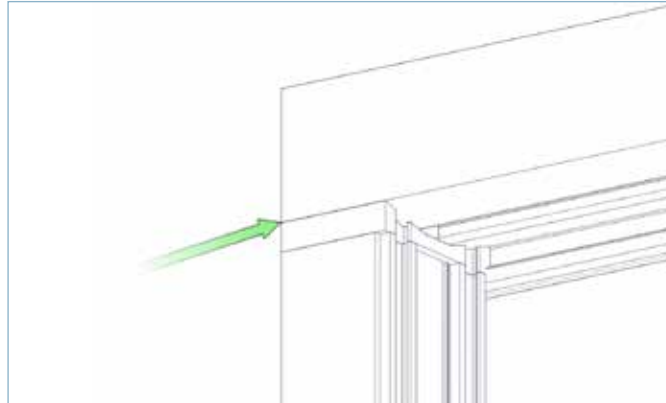

FIG 5D

▶ **5.6.** Install a fixing in the top track approximately 100mm in from the jamb as shown in FIG 5E, being careful not to lift the track from the top of the jamb when the fixing is tightened.

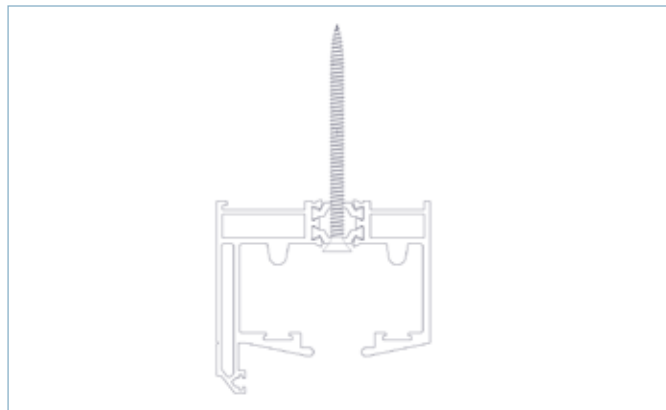

FIG 5E

▶ **5.7.** Using the string line and pinch rod or measuring staff, make sure the track does not bow inside to out, or up and down, as shown in FIG 5F.

▶ **5.8.** Install the remaining fixings into the top track in line with the bottom track fittings, being careful not to bow or twist the track.

▶ **5.9.** Trim and reinstall the track gasket.

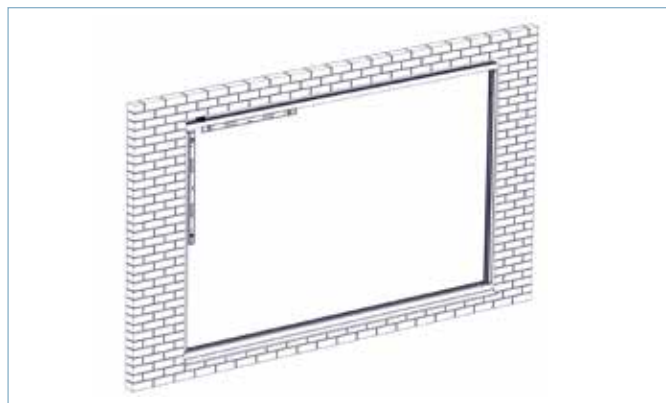

FIG 5F

6. Top and bottom trolley

- ▶ **6.1.** Remove the bottom carriage and trolley assembly from its packaging, and using a 4mm frame packer, check the ride height is set correctly as shown in FIG 6A.
- ▶ **6.2.** Place the bottom carriage and trolley assembly into the bottom track as shown in FIG 6B. The trolley should point to the outside if the doors are open-out, and inside if the doors open-in. Repeat this process until all bottom carriage assemblies have been installed.
- ▶ **6.3.** Install all top trolley guide wheels and move down the track to the opposite end. The thicker side of the wheel should be on top as shown in FIG 6C.
- ▶ **6.4.** Insert the top trolley between two guide wheels and lower down to locate the pins into them from above, as shown in FIG 6D and 6E. Repeat this process until all top trolleys are installed.



FIG 6A

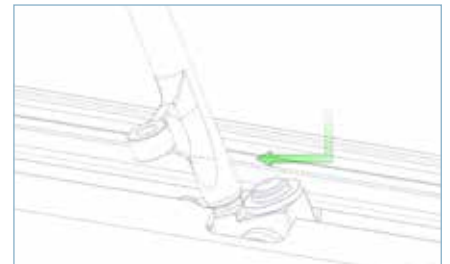

FIG 6B

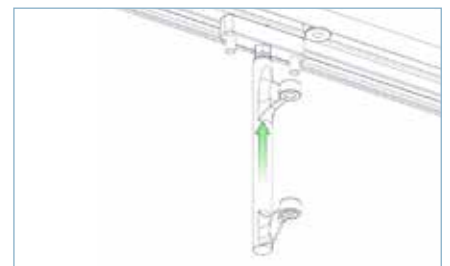

FIG 6D

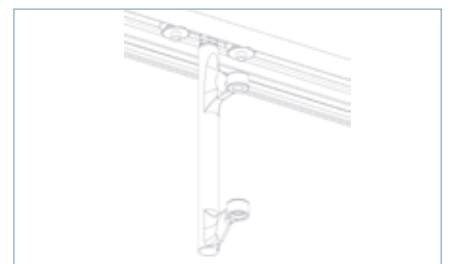

FIG 6E

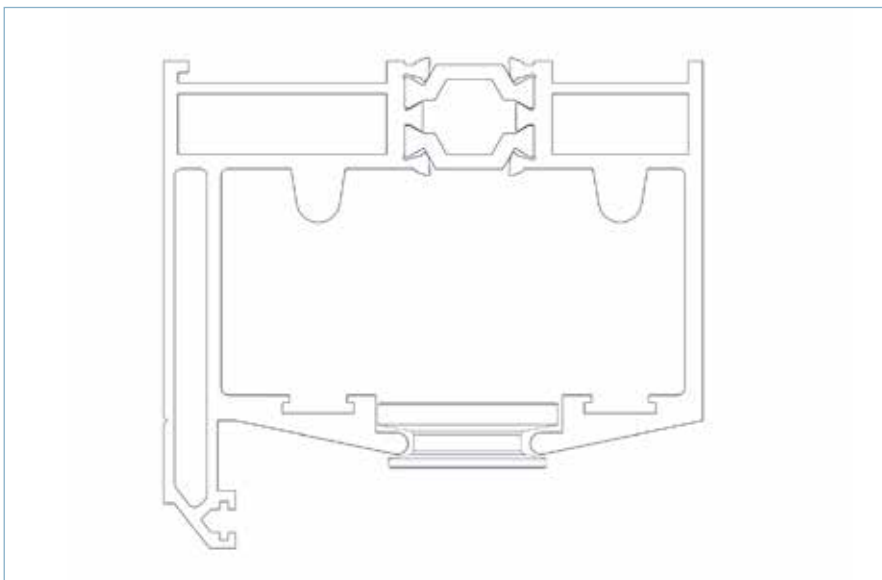

FIG 6C

7. Door leaves

- ▶ **7.1.** Locate the trolley pins and bolts from the components bag.
- ▶ **7.2.** Hang the first door on the hinge jamb as shown in FIG 7 A and B with the label at the top and facing out.
- ▶ **7.3.** Hang the second door onto the hinges of the first door, again with the label at the top and facing out as shown in FIG 7C.
- ▶ **7.4.** Close the two doors across the track and lock into place with the slave handle, being careful not to scratch the track as the doors cross it.
- ▶ **7.5.** Hang the third door onto the centre hinge and insert a screwdriver through the top hinge; this will support the door whilst the trolleys are located as seen in FIG 7D.
- ▶ **7.6.** With the third door completely open, locate the bottom trolley around the bottom hinge between the second and third doors.
- ▶ **7.7.** Remove the screw and insert the trolley pin into the bottom trolley and hinge using a plastic hammer to gently tap the pin in fully, being careful to align the hinge and trolley as the pin goes through as shown in FIG 7E.
- ▶ **7.8.** Reinstall the screw and tighten using a t30 Torx key.
- ▶ **7.9.** Remove the screwdriver from the top hinge and locate the top trolley around the hinge.
- ▶ **7.10.** Insert the second trolley pin bolt as described in points 7.8. and 7.9.
- ▶ **7.11.** Repeat steps 7.1 to 7.12 until all door leaves are hung.

Note

When closing the master/lead door for the first time, ensure that contact with the locking jamb or stile does not occur. If contact occurs, adjust the doors as described in section 14.

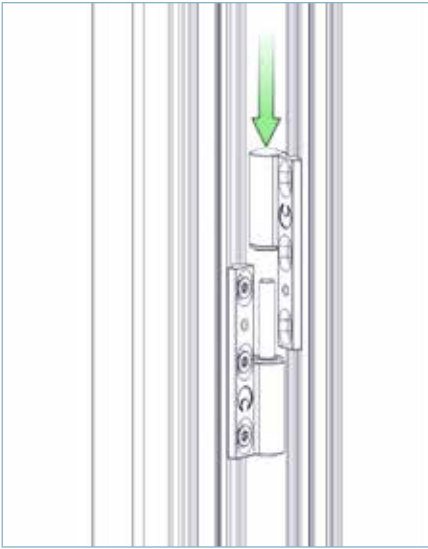

FIG 7A

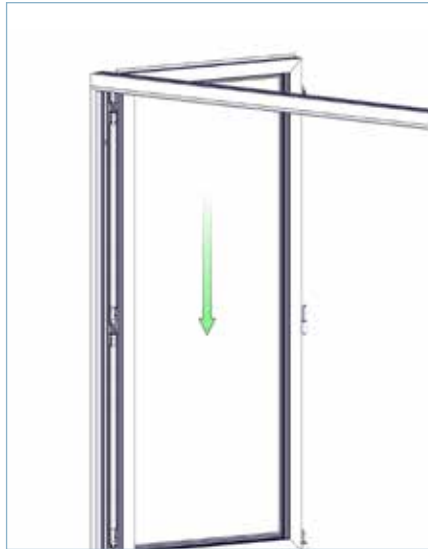

FIG 7B

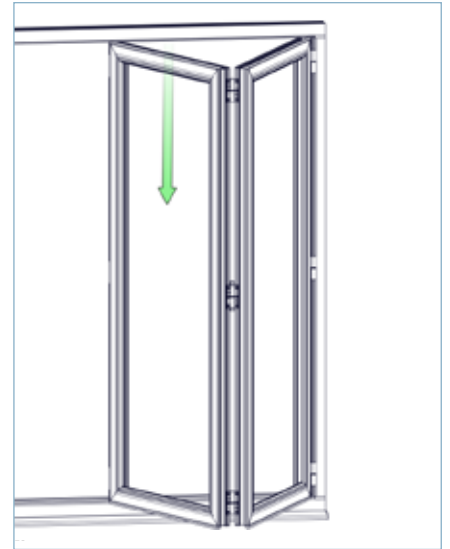

FIG 7C

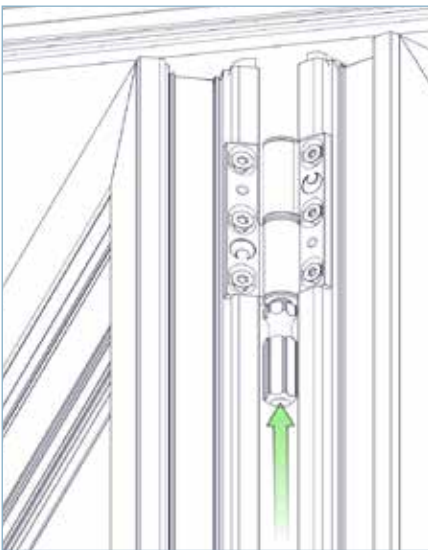

FIG 7D

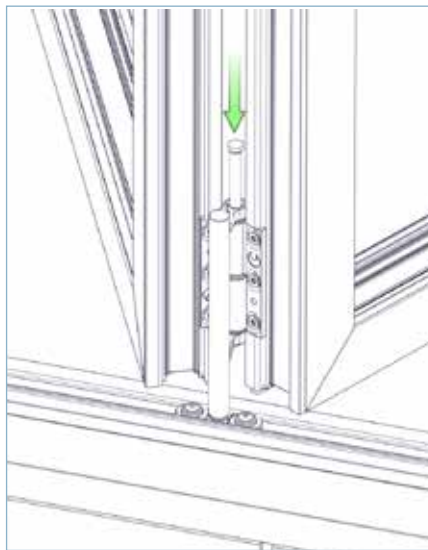

FIG 7E

8. False mullion

(even number of doors moving in the same direction only)

- ▶ **8.1.** Remove the centre hinge from the mullion.
- ▶ **8.2.** With the last door at 90° to the tracks, locate the top and bottom trolleys around the hinges.
- ▶ **8.3.** Position the mullion into the tracks and slide along to mate with the hinges and trolleys as shown in FIG 8A.
- ▶ **8.4.** Insert both top and bottom trolley pins as described in the previous section.
- ▶ **8.5.** Replace the centre hinge and screws being careful not to cross thread the screws.

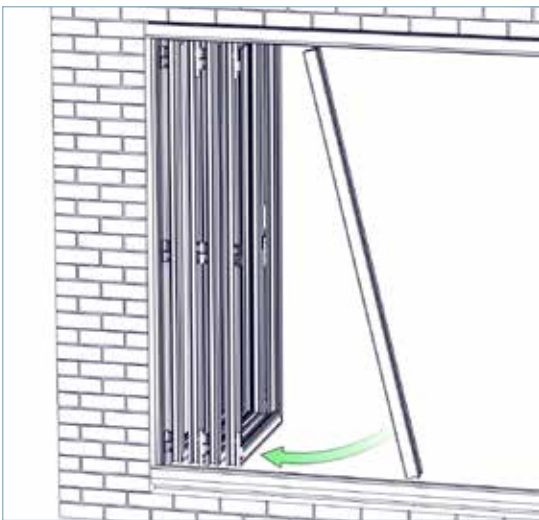

FIG 8A

9. Handles

D-handles (open-out only)

- ▶ **9.1.** Position the D-handle over the centre hinge above the slave handle.
- ▶ **9.2.** Fix the handle top and bottom using the D-handle fixings. These may need a gentle tap to locate the thread.

D-handle



Hafi handles



Long Back Plate Lever/ Lever Handles

- ▶ **9.3.** Remove the screws from the lever handle, allowing the two halves to be separated.
- ▶ **9.4.** Insert the spindle and a return spring (if supplied) into the outer part of the handle. (The outer handle will have the thread for the handle screws).
- ▶ **9.5.** Making sure the lever is across the glass, insert the spindle into the lock.
- ▶ **9.6.** Locate the handle around the barrel and flush against the door.
- ▶ **9.7.** Install the internal part of the handle and second return spring (if supplied), again with the lever across the glass.

NOTE: Always keep a hand on the external handle to prevent damage.

NOTE: It may be necessary to slacken the retaining screw on the barrel to help alignment. Always re tighten.

- ▶ **9.8.** Install the two screws and carefully tighten with a hand screwdriver only.

Hafi Stainless Steel Handles (separate handle and barrel)

- ▶ **9.9.** Locate the handles and 4 no. 20mmxM5 screws from the components box.
 - ▶ **9.10.** Remove the escutcheons from both handles.
 - ▶ **9.11.** Insert the spindle into one lever and nip the grub screw using a 3mm Allen key.
 - ▶ **9.12.** Install the handle and spindle into the door with the lever across the glass.
 - ▶ **9.13.** Insert the 20mm x M5 screws and tighten using a Pozi 2 hand screwdriver only, being careful not to cross thread the screws.
 - ▶ **9.14.** Install the remaining lever onto the door and secure in place, as described in the previous step and nip the remaining grub screw.
 - ▶ **9.15.** Install both inner and outer escutcheons with the small cut out pointing down.
- NOTE:** It may be necessary to use a rubber mallet to gently tap the escutcheons fully into position.

10. Centre hinge

(open-in only)

- ▶ **10.1.** Open the doors and locate the missing centre hinges.
- ▶ **10.2.** Making sure the two halves of the top and bottom hinges are together, install the centre hinge, being careful not to cross thread the screws.

NOTE: All hinges will be found in the components box.

11. Glazing the doors

- ▶ **11.1.** Close all doors and fully engage the locks.
- ▶ **11.2.** Starting with the door next to the hinge jamb, remove the 4 glazing beads.
- ▶ **11.3.** Place 2 no. 4mm packers (32mm wide minimum) in the bottom of the glazing chamber spaced approximately 50mm in from each corner at 90° to the door, as shown in FIG 11A.
- ▶ **11.4.** Install the glass on to the packers, taking care not to pinch the gasket on the outside.
- ▶ **11.5.** Insert another 4mm packer (32mm wide minimum) to the side of the glass diagonally opposite the toe and heel plate about 50mm up from the corner, making sure to support the inner and outer layers of the glass, as shown in FIG 11B.
- ▶ **11.6.** Using a glazing paddle at the bottom, lift the glass and turn the packer which is diagonally opposite the toe and heel plate so it is in line with the glass, making sure inner and outer layers are supported, as shown in FIG 11B.
- ▶ **11.7.** Remove the second packer from under the glass and insert into the side, at the top of the door diagonally opposite the first two packers, making sure inner and outer layers of glass are supported.
- ▶ **11.8.** Using the glazing paddle, lever the door up and place a 4mm glazing packer (32mm wide minimum) between the top of the glass and the toe and heel plate, making sure both inner and outer layers of the glass are supported.
- ▶ **11.9.** Reinstall all 4 glazing beads starting with the top and bottom.
- ▶ **11.10.** Repeat steps 11.4 to 11.9 until all the glass is in place.

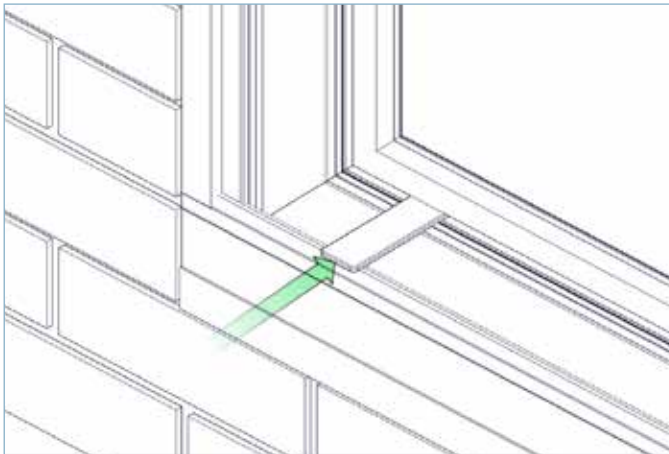

FIG 11A

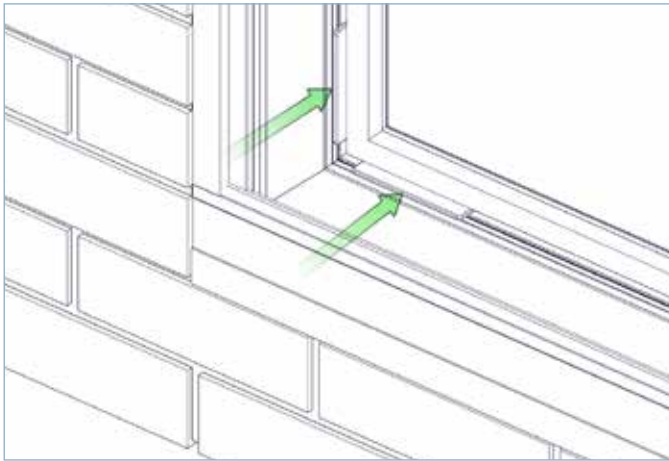

FIG 11B



FIG 11C

Notes

The packer positions will always be set by the location of the toe and heel plate and will be opposite to the adjoining door, as shown in FIG 11C.

If the glass is not square or stepped, it may be necessary to use a thinner packer between the glass and toe and heel plate. These should always be a minimum of 32mm wide.

12. Installing the wedge gasket

- ▶ **12.1.** Starting with the bottom bead, use the glazing paddle to gently lever the bead away from the glass and into the correct position whilst lifting the side beads.
- ▶ **12.2.** Place the gasket between the glass and bead with the concave side against the glass.
- ▶ **12.3.** Feed the gasket behind the side bead until it stops and then continue along the bottom bead compressing the gasket towards the start point.
- ▶ **12.4.** Repeat steps 12.1 to 12.3 with the top bead.
- ▶ **12.5.** Cut a slight angle on the end of the gasket and insert behind the side bead pushing up to meet the top gasket.
- ▶ **12.6.** Continue to feed the gasket along the side bead, compressing towards the starting point.
- ▶ **12.7.** Once the bottom is reached, cut the gasket approximately 5mm past the bottom gasket again with a slight angle to meet the bottom gasket.
- ▶ **12.8.** Repeat steps 12.5 to 12.7 with the remaining side.
- ▶ **12.9.** Repeat steps 12.1 to 12.8 with the remaining doors.

13. Toe and heel adjustment

- ▶ **13.1.** If adjustment is needed, you will find a toe and heel device in the top of each door.
- ▶ **13.2.** Open the doors so that you can get access to the toe and heel device at the top of the door. Using a 4mm Allen key, wind the bolt clockwise, causing the side of the door to rise.
- ▶ **13.3.** Re-close the doors and check that they run parallel and evenly to the top and bottom tracks. If they do not, then repeat as necessary.
- ▶ **13.4.** Once you have adjusted the doors, make sure that each toe and heel plate is tight to the glass in each door, this will prevent the doors from settling over time.

14. Adjustment

NOTE: All adjustment comes from the outer frame.

Tracks

- ▶ **14.1.** To check the top and bottom tracks are parallel, open all the door leaves completely.
- ▶ **14.2.** At this point, the pins in the centre of the top guide wheel should be fairly flush with the visible face of the guide wheel, as shown in FIG 14A. Move the doors along the track whilst monitoring the pins in the top guide wheels. If the top and bottom tracks are parallel, the visible pin should remain the same as at the start.
- ▶ **14.3.** If the visible pin decreases at any point, the top track will need repacking to raise it up at these points.
- ▶ **14.4.** If the visible pin increases at any point, the top track will need repacking to lower it at these points.

NOTE: The bottom track must be well supported and level for the description above to be correct.

Jambs

- ▶ **14.5.** When the lead door is closed, there should be a visible gap of 4mm between itself and the jamb or locking style, adjust as follows if necessary.*
- ▶ **14.6.** Remove the two centre fixings from one jamb.
- ▶ **14.7.** Remove the top fixing from that jamb.
- ▶ **14.8.** Repack the top of the jamb to give a 4mm gap between the edge of the lead door and jamb.
- ▶ **14.9.** Replace the fixing in the top of the jamb.
- ▶ **14.10.** Remove the bottom fixing from the jamb.
- ▶ **14.11.** Repack the bottom of the jamb to give a 4mm gap between the edge of the lead door and jamb.
- ▶ **14.12.** Replace the fixing in the bottom of the jamb.
- ▶ **14.13.** Pack and replace the remaining two fixings, keeping the even 4mm gap.

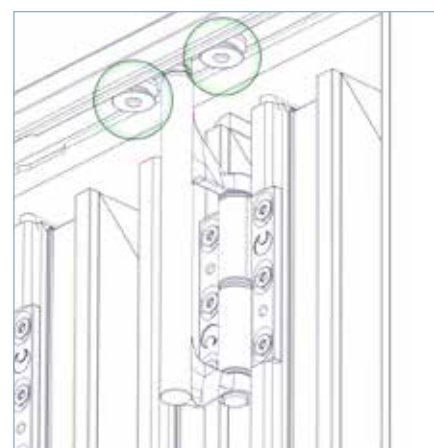

FIG 14A



FIG 14B

*This is temperature dependent. When installing in particularly hot weather, the gap along the slam and rebate may need reducing slightly. In particularly cold weather, this gap may require increasing slightly. This accounts for the minimal potential expansion and contraction with the aluminium profile.

15. Magnetic keep

- ▶ **15.1** Locate the magnetic keep from the components box.
- ▶ **15.2** Open the lead door almost 180° until the handle is approximately 10mm from the adjoining door and hold in position.
- ▶ **15.3** Position the complete magnetic keep up between the top of both doors and move along until it is wedged between them, as shown in FIG 15A.

- ▶ **15.4** Using a pencil, mark the magnet holder position on the lead door.

NOTE: If the door is above 2700mm, repeat steps 15.2 - 15.4 for the bottom magnetic keep.

- ▶ **15.5** Close the lead door.
- ▶ **15.6** Return the magnet holder to your mark and move up or down to position in the centre of the door profile. The centre of the hole should be 26mm down from the top of the door.
- ▶ **15.7** Using a 3.5mm drill bit, mark the door through the hole in the magnet holder, as shown in FIG15B.
- ▶ **15.8** Remove the holder and using the 3.5mm drill bit, drill a hole on the previously made mark.
- ▶ **15.9** Install the magnet and cover plate.
- ▶ **15.10** Place the two halves of the magnetic keep together.
- ▶ **15.11** Open the lead door against the adjoining door to locate the second half and mark with a pencil.
- ▶ **15.12** Fix in position as previously described.
- ▶ **15.13** Install cover plate.



FIG 15A

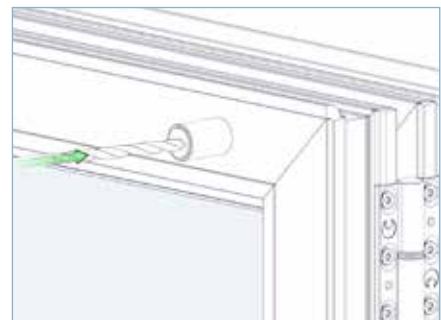

FIG 15B

16. Finishing touches

- ▶ **16.1** Insert fixing plugs provided into the 13mm holes drilled into the jambs.
- ▶ **16.2.** Insert the hinge plugs into the top and bottom of all open hinges.
- ▶ **16.3.** We recommend you use expanding foam to fill the gaps between the outer frame and building on all 4 sides.

NOTE: The weather seal around the outer frame to the building is the responsibility of the installer. Sealant and trim kits are available from Origin.

Door Restrictor Installation Guide

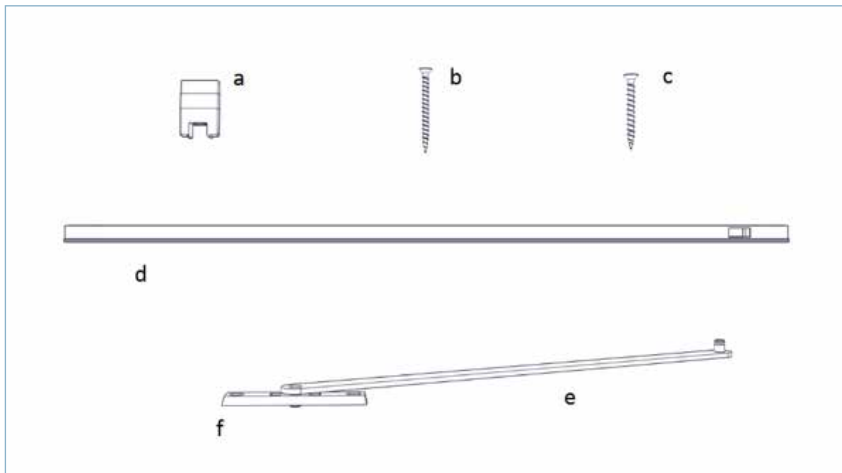

1. Check you have all of the parts

- a. Restrictor Block (x5)
- b. Screws (x4) 5.0 x 60mm
- c. Screws (x3) 5.0 x 45mm
- d. Slider Casing (x1)
- e. Restrictor Bar (x1)
- f. Sash Pivot (x1)



2. Prop the door open to the desired maximum angle.



3. Ensure the slider stop is engaged by placing point (A) against a hard surface and pushing down on the restrictor arm. This will require some force and should result in a click. The restrictor arm should no longer be able to slide up and down the slider housing once this step has been completed.

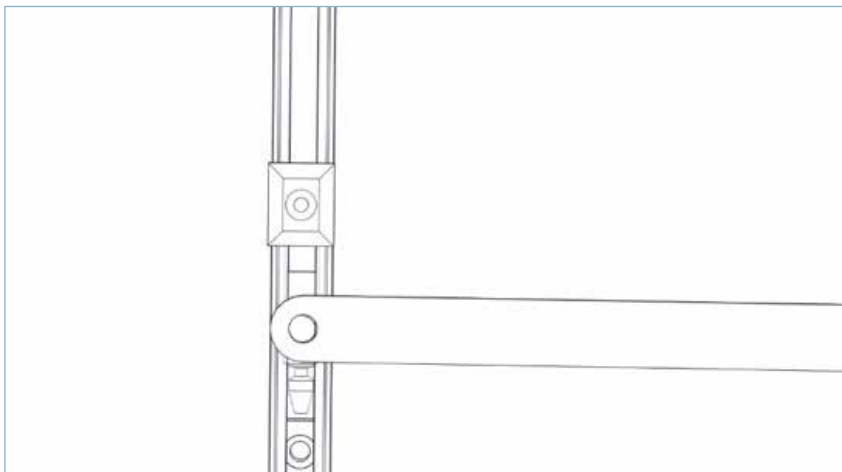

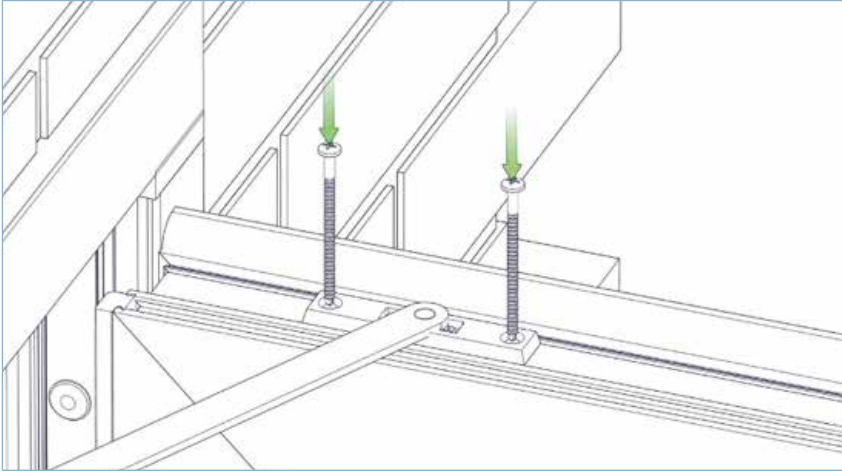

4. Fit the sash pivot to the top of the door, 60mm from the end of the black polyamide strip on the hinge side using two of the 5.0 x 45mm screws provided. The pivot should be fitted so that it butts up to the edge of the polyamide closest to inside of the door.

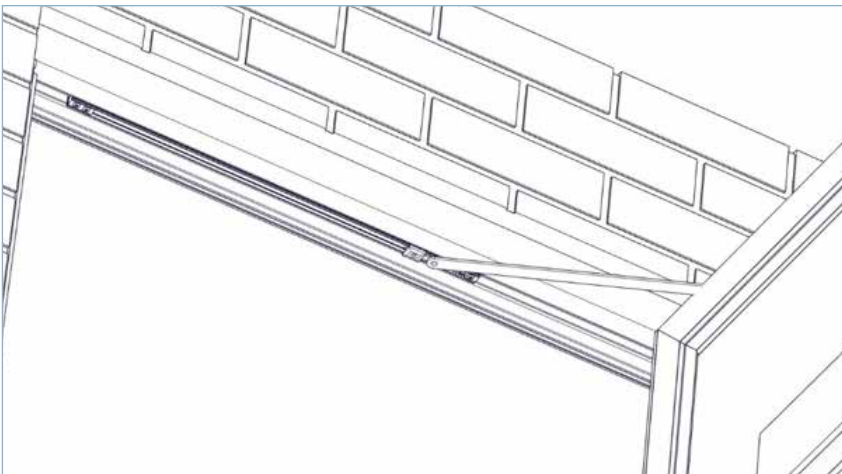

5. Insert the slider casing into the top track making sure it is still connected to the sash pivot, it should only fit in one position. Then, using a non-permanent method, mark the positions of the four screw holes in the slider casing, then move the slider casing out of the way.

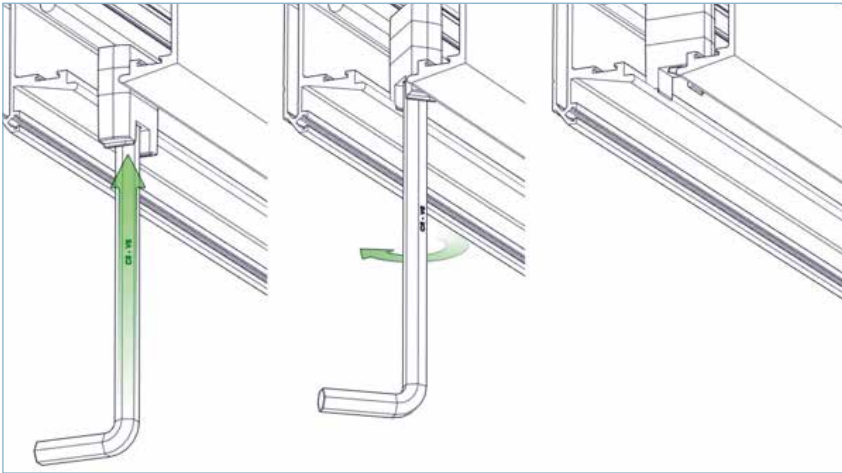

6. Insert four of the restrictor blocks positioned at the points you have marked on the top track. Do this by using an 8mm Allen key to insert the block into the track and twisting 90° clockwise to lock it in to place. The 5th restrictor block is then inserted half way between the other blocks.

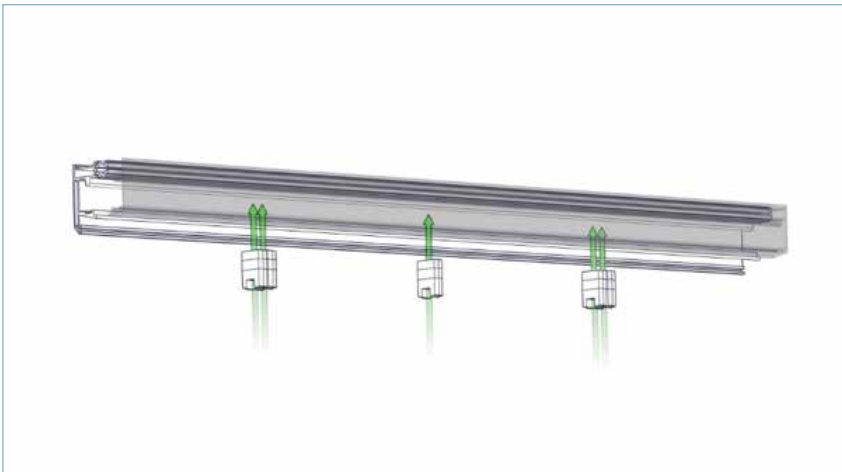

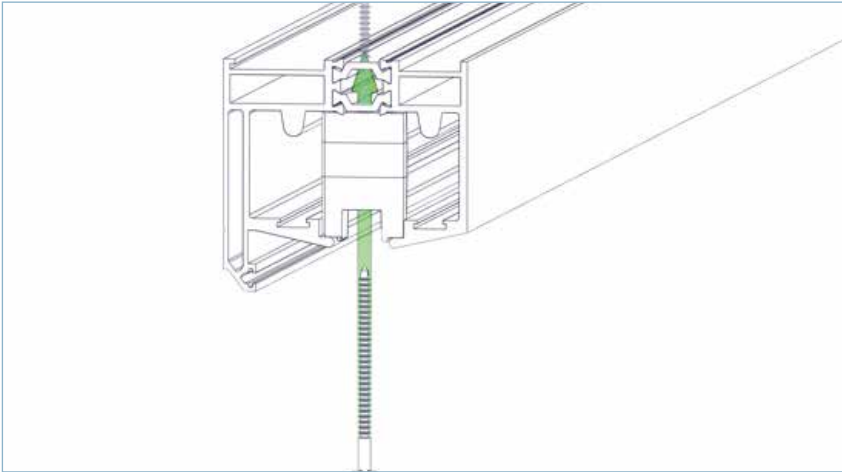

7. Using one of the 5.0 x 45mm screws, secure the middle restrictor block as shown.

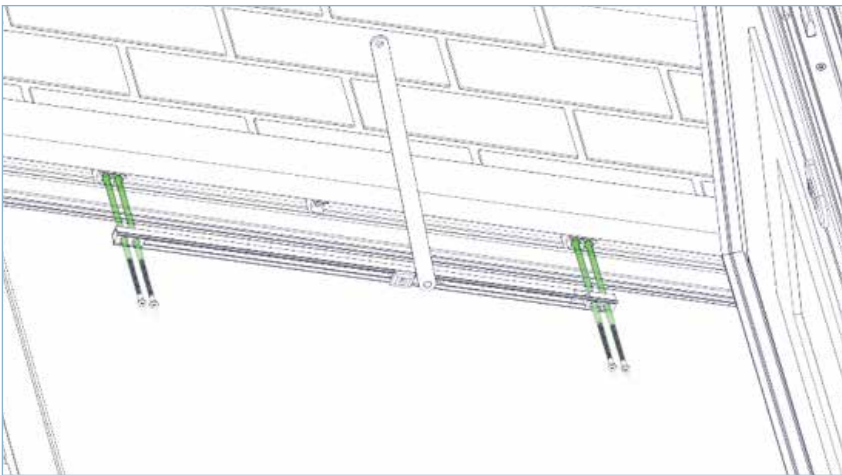

8. Now place the slider casing back into the top track at your marked position, and secure the last 4 restrictor blocks through the slider casing using the 5.0 x 60mm screws as shown. It may help to disconnect the sash pivot at this point for ease of installation. Once the screws have been fitted reconnect the sash pivot. Check the door for proper operation.

Door-to-Window Installation Guide

- ▶ The coupler is only to be used vertically. The maximum length of a coupler is 3000mm.
- ▶ Fixings are to be placed 150mm from the ends and at 400mm centres.
- ▶ Ensure you make the appropriate deductions to your products (a total of 15mm or 7.5mm on each product).

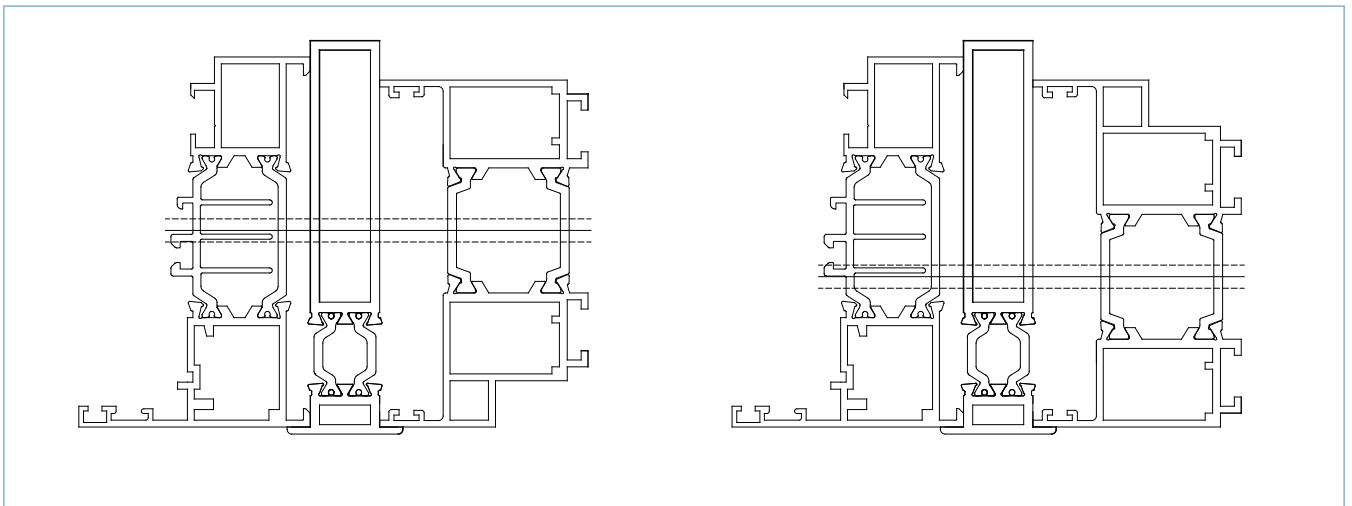
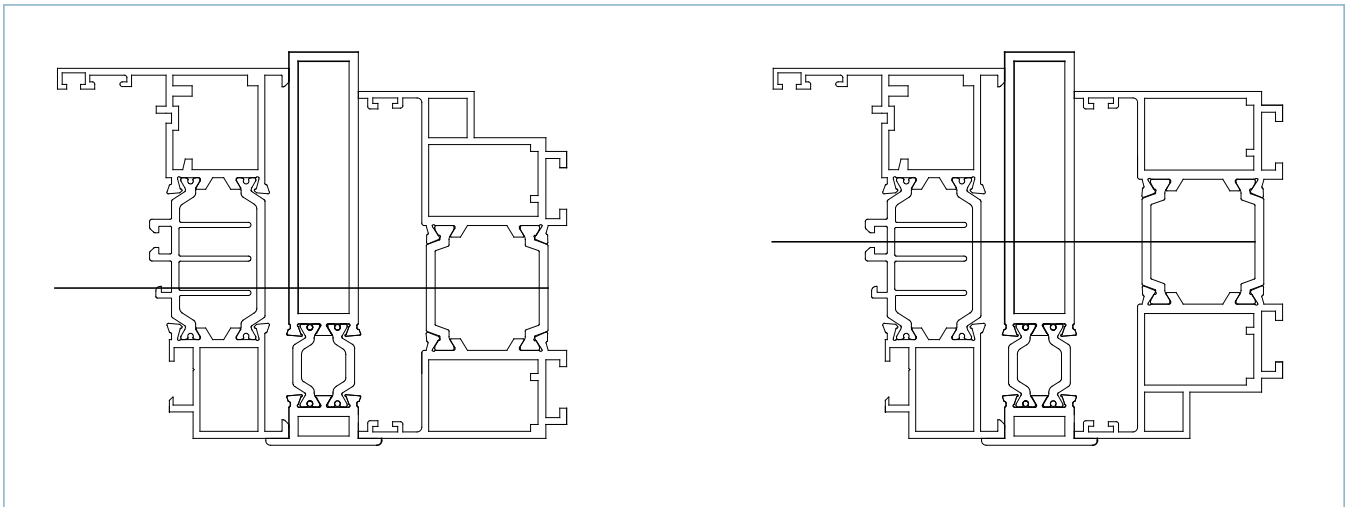

Door to OW-80 fixing positions

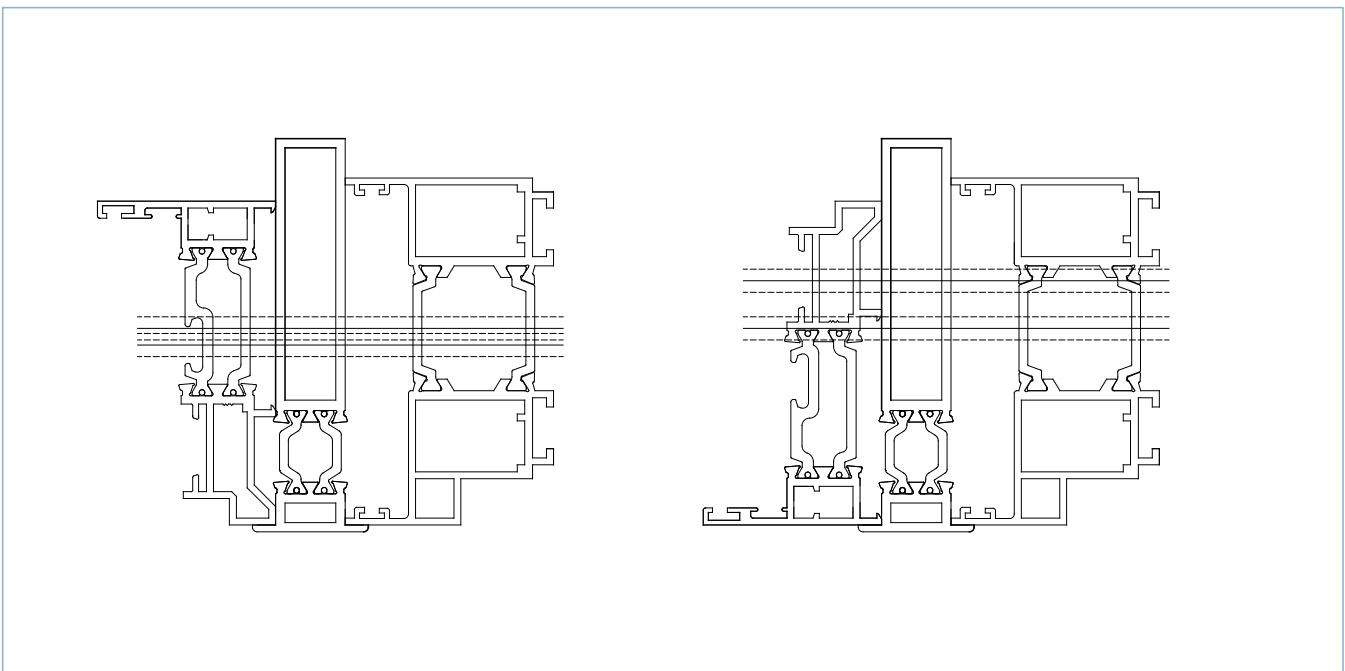
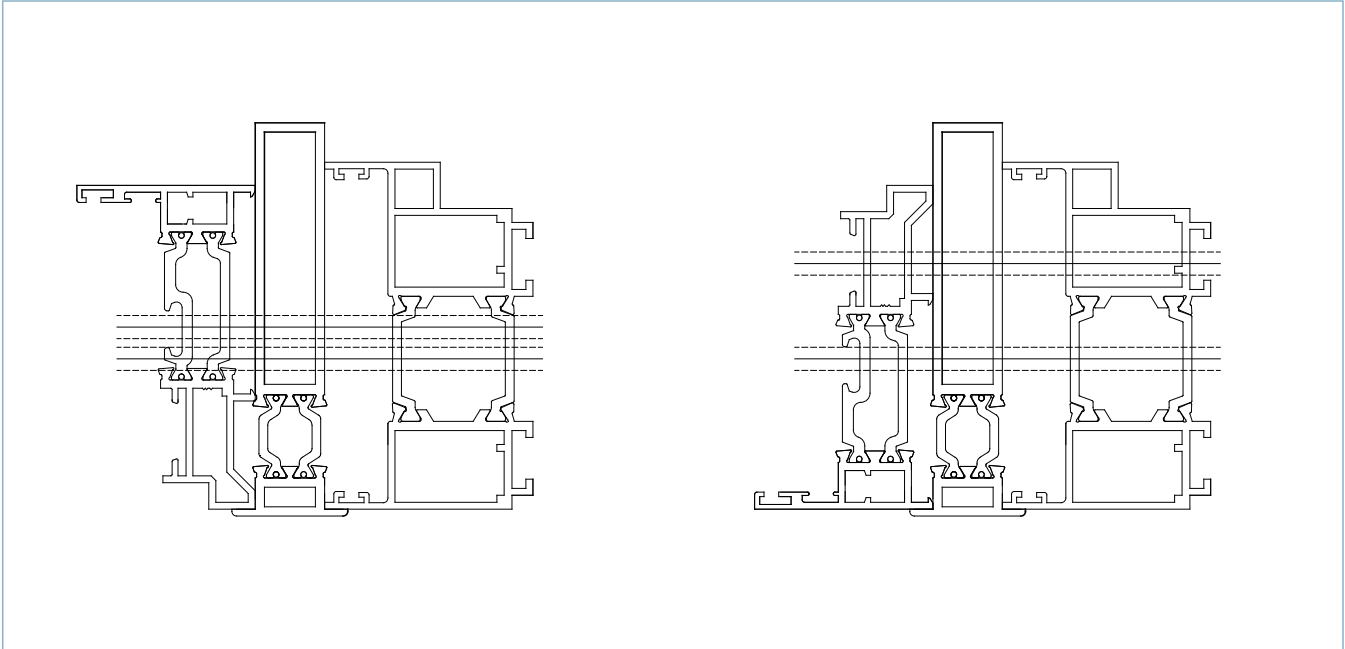

Door to OW-70 fixing positions

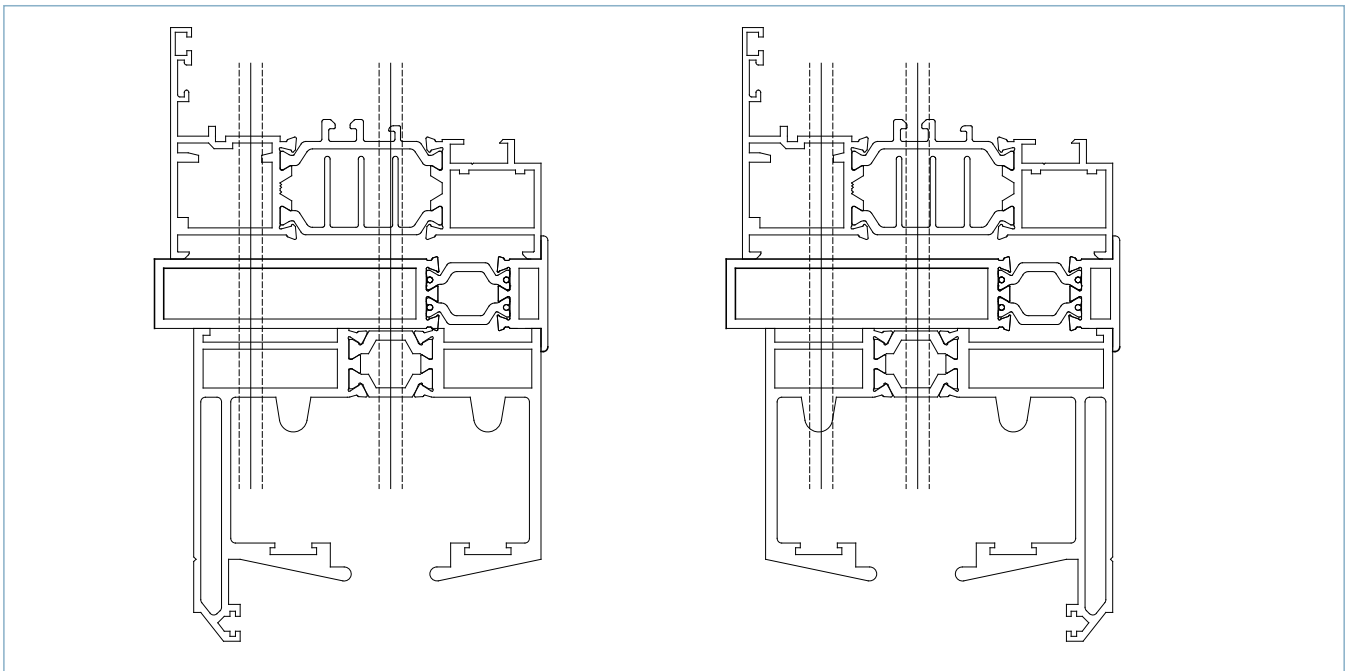
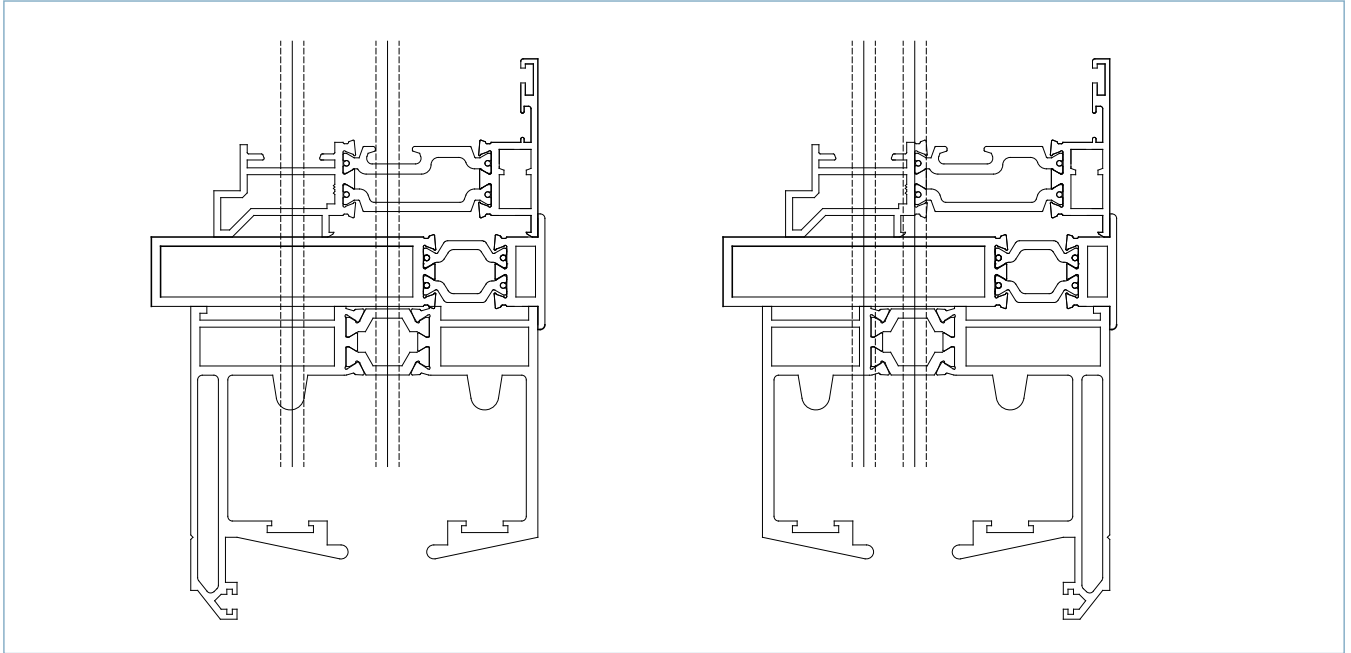

Window above door fixing positions

Window-to-Jamb Coupler Installation Guide

Install the windows
as described in the
Installation Guide

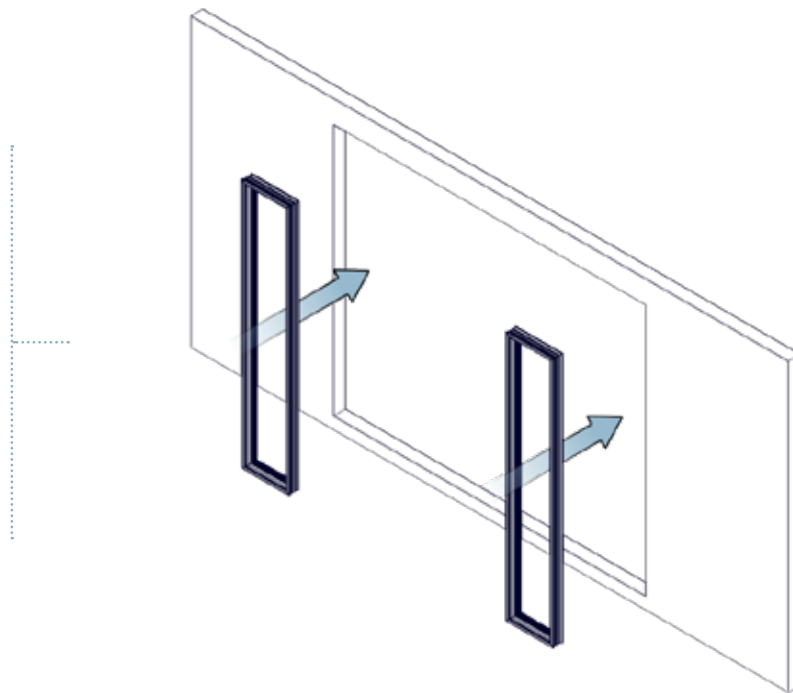

Ensure the remaining
aperture is 6mm wider
than the overall door
set width

Do not install the glass

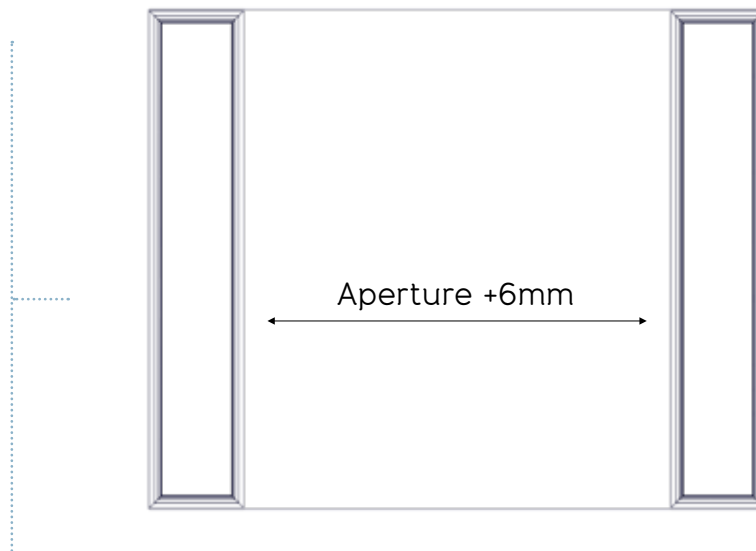

Window-to-Jamb Coupler Installation Guide

Install the alignment block into the window frame

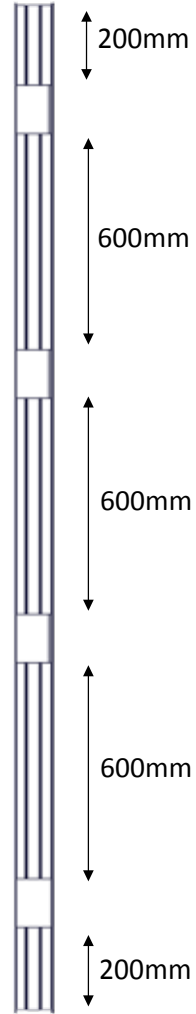
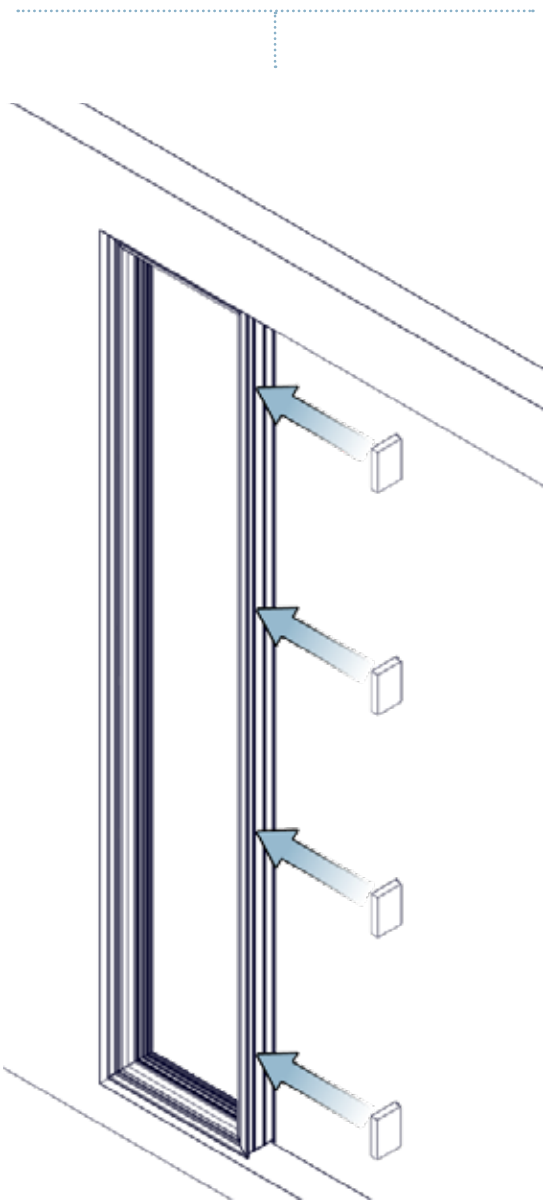

Leave 200mm from each end and evenly space the rest appropriately

Drill, countersink and fix alignment blocks



Ensure screw is flush with surface of the block

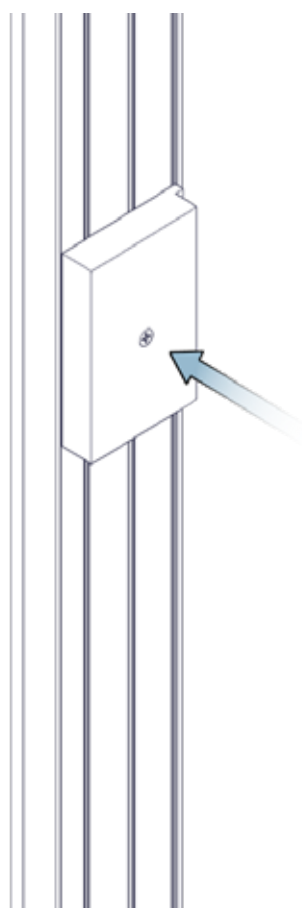
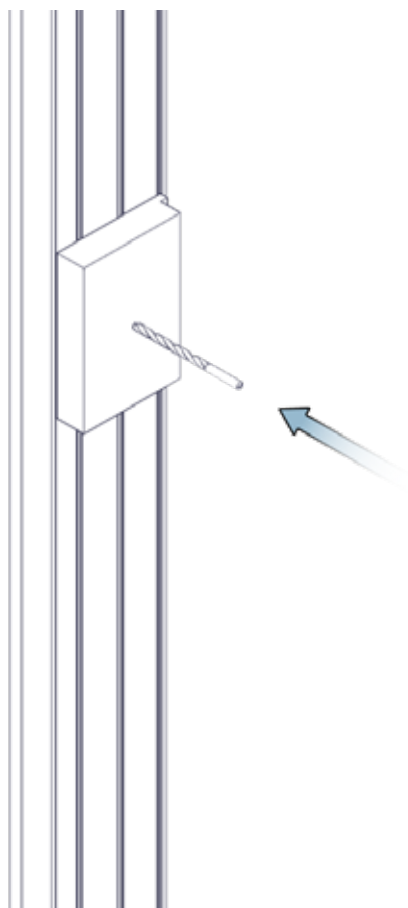

Window-to-Jamb Coupler Installation Guide

Cut down 5mm frame packers to 72mm (one for each jamb packer)

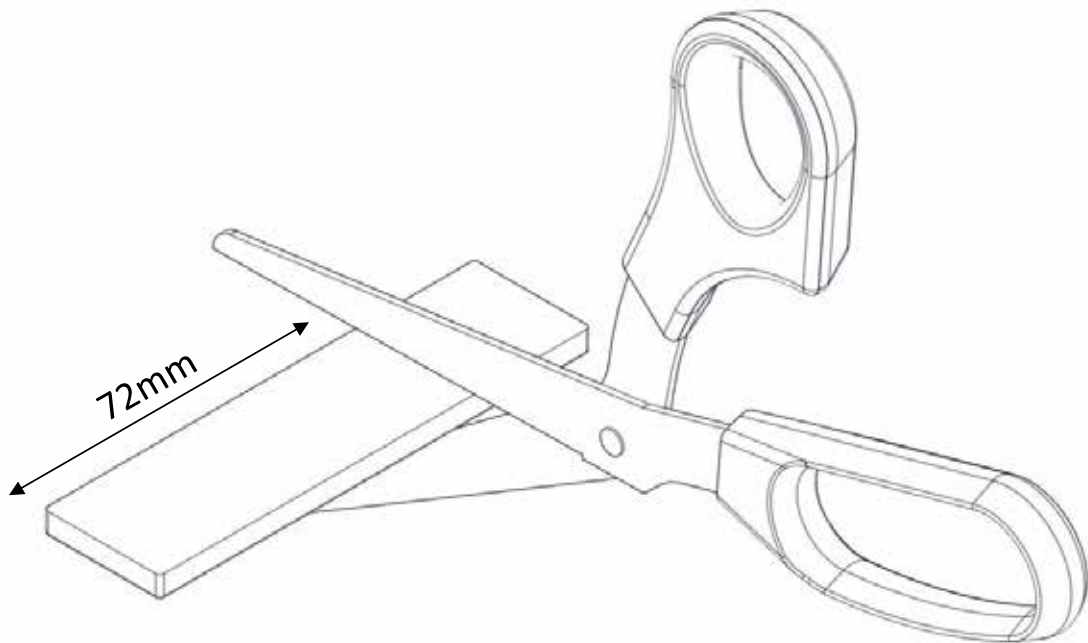

Install the glazing packers

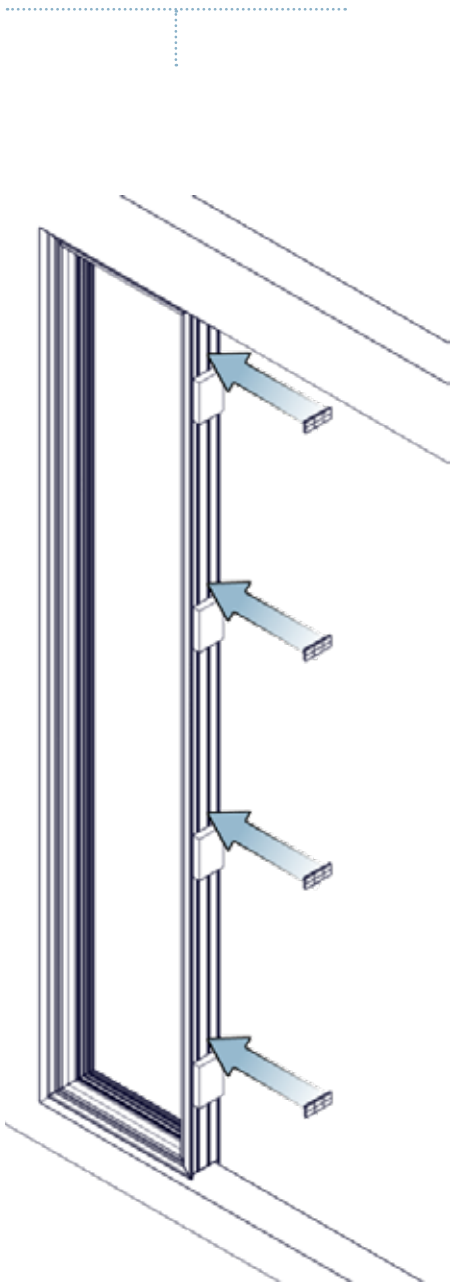

Ensure packers are positioned next to the alignment blocks

Window-to-Jamb Coupler Installation Guide

Re-position the jamb packers in the jamb

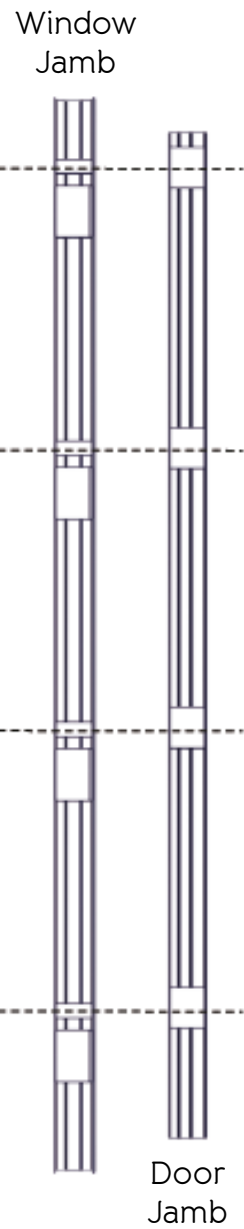
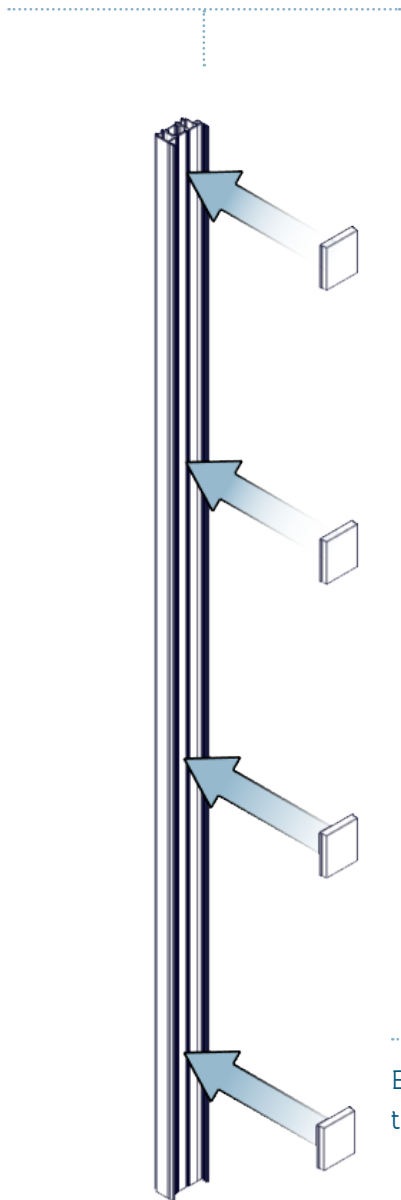

Ensure packers are spaced the same as the frame packers installed on the window frame and fix appropriately

Position the door frame
into the aperture and
pack/ clamp accordingly

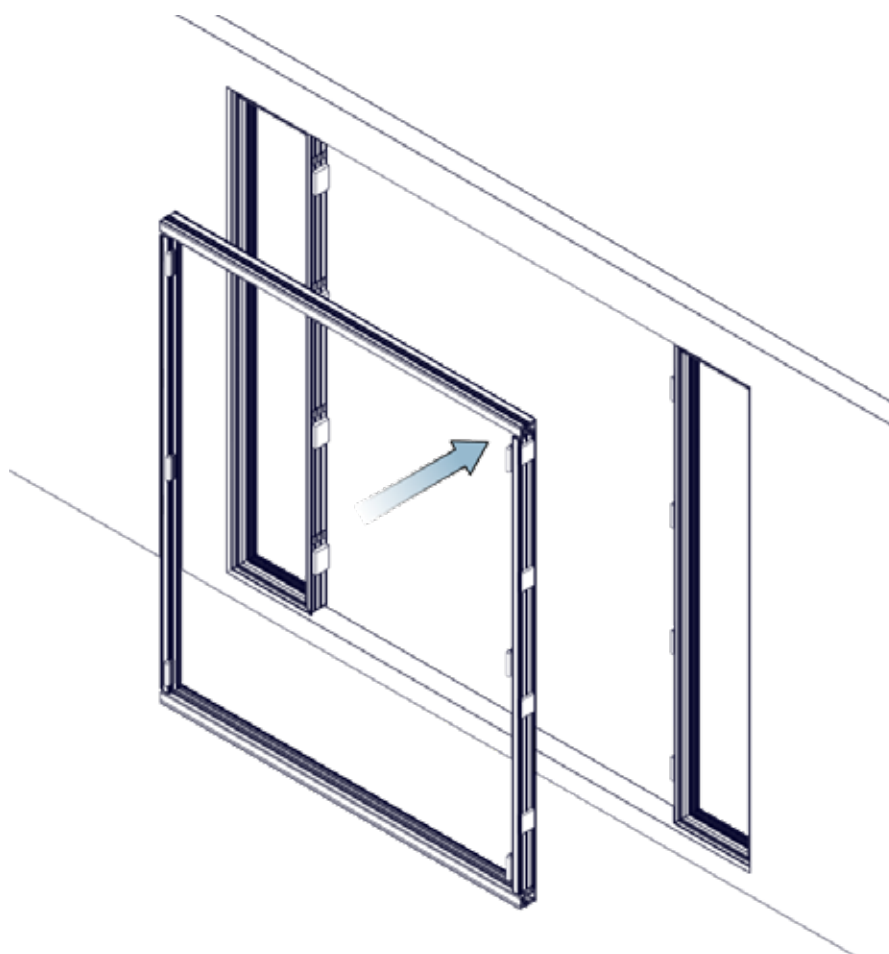

Window-to-Jamb Coupler Installation Guide



*Do not drill into
gasket chamber*

Pre-drill the frame
with a 3mm drill bit as
shown for every jamb
packer used

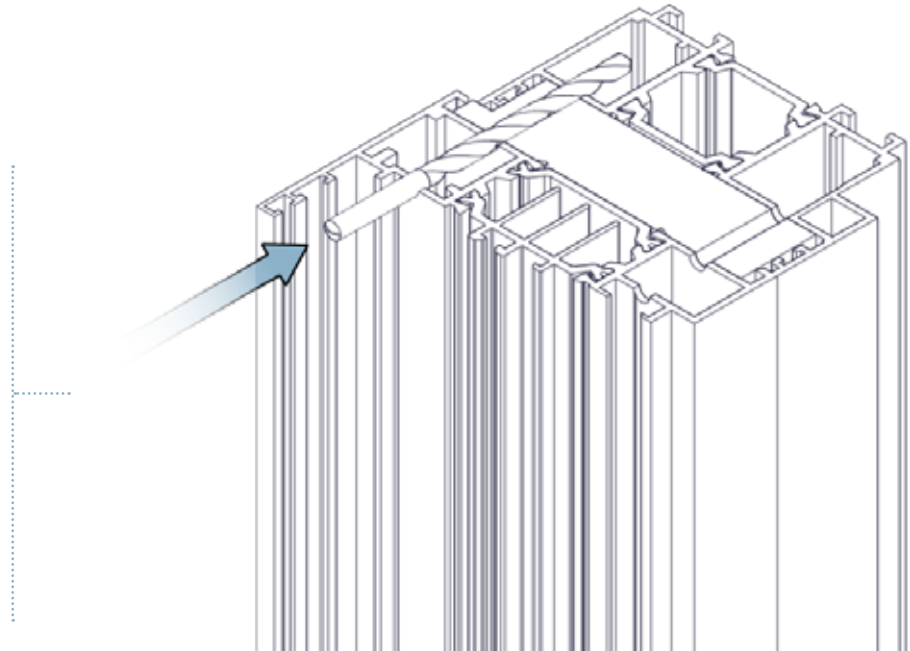

Using supplied screws, fix
the window frame to the
door jamb through the
jamb packers

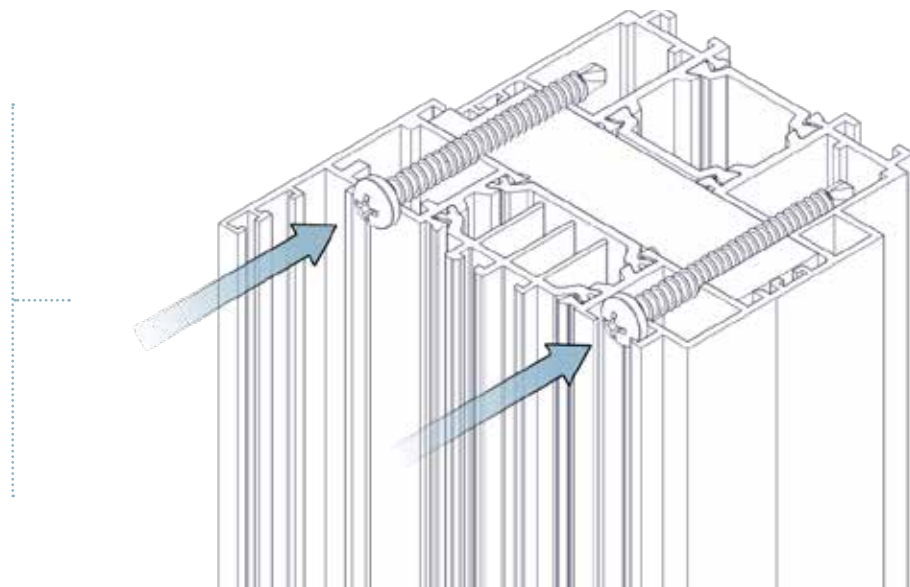

Window-to-Jamb Coupler Installation Guide

Install door sash, windows and glass as described in the Installation Guide

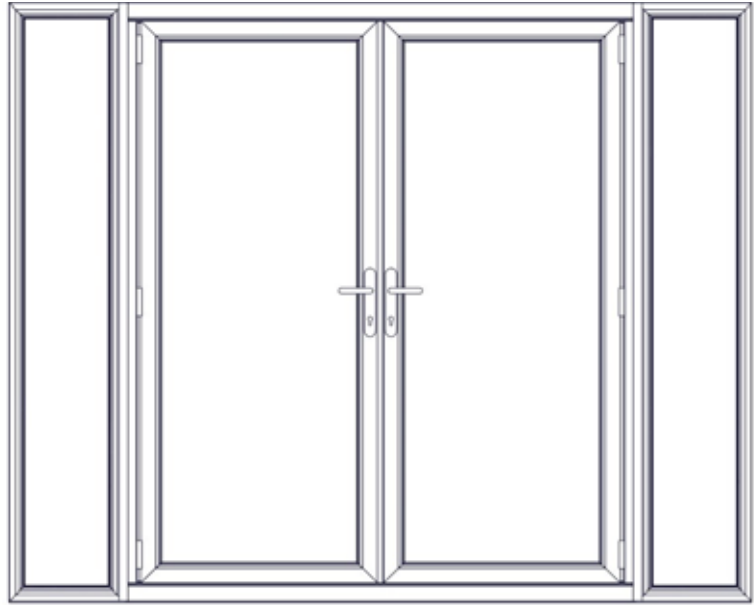

Seal the joint, between the window and door frame, making sure the joint is completely weatherproof

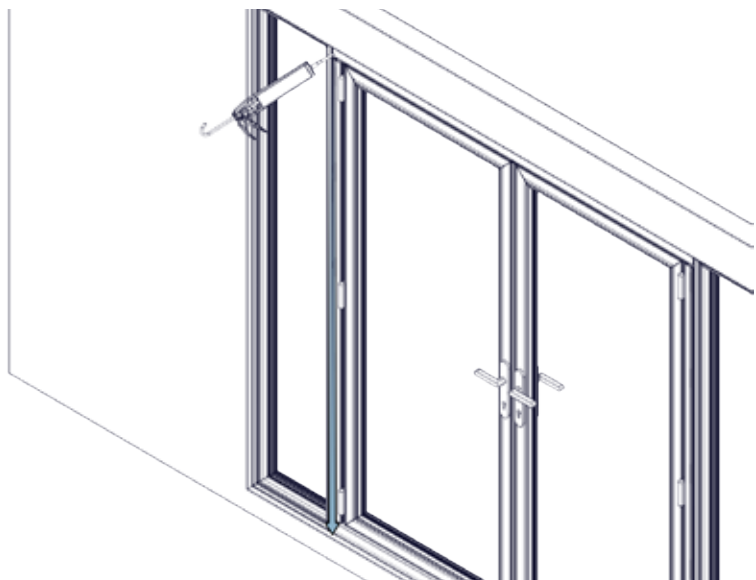

Window-to-Jamb Coupler Installation Guide

Cut and fit supplied trim inside (flat) ...

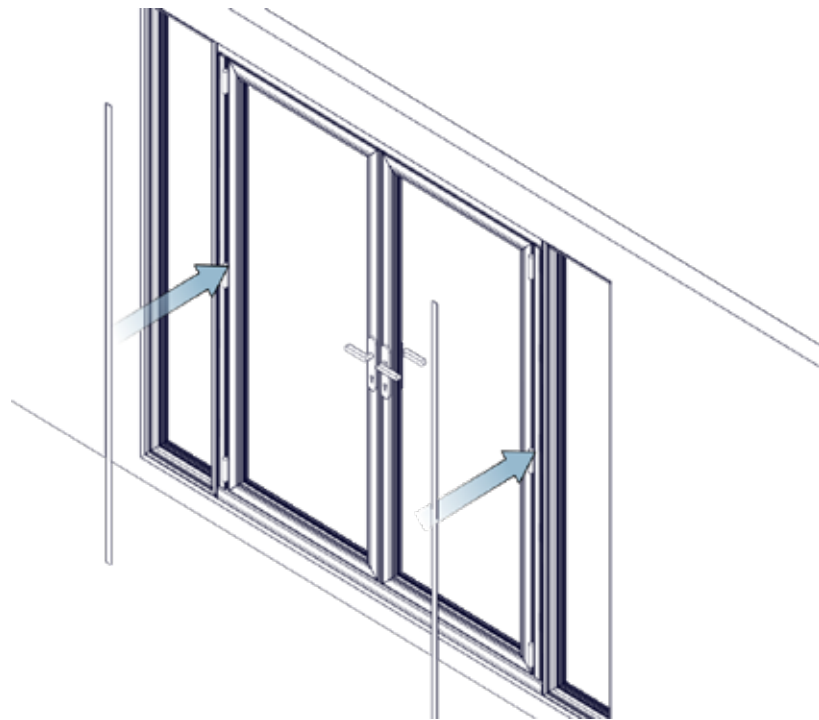

...and out (stepped)

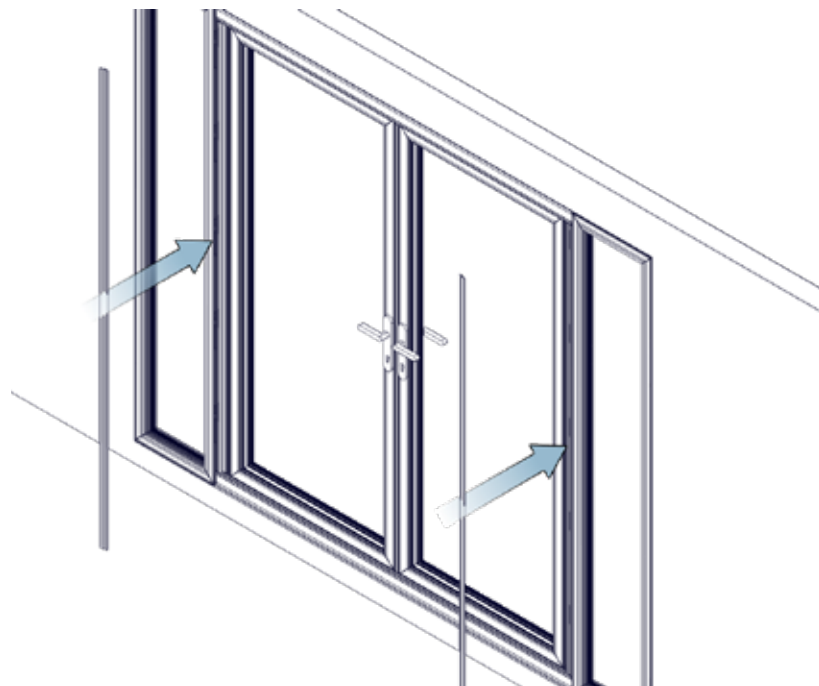

Window-to-Track Coupler Installation Guide

Install door jambs and tracks as described in the Installation Guide

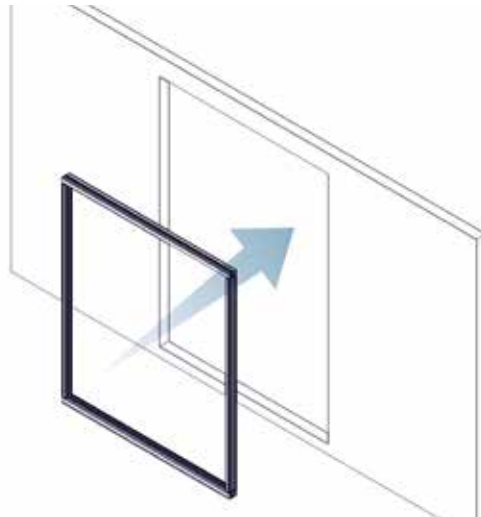

Place fixing blocks along the top track

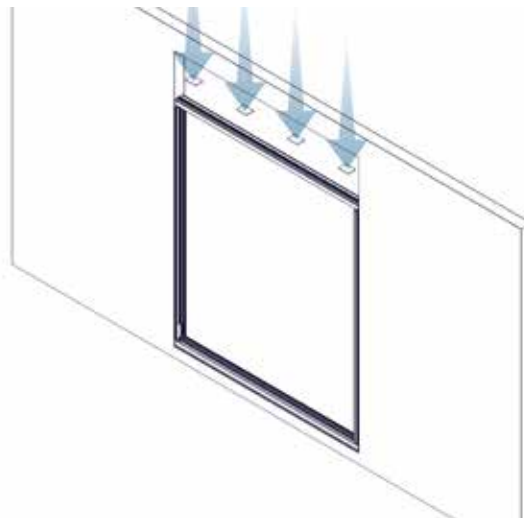

Ensure blocks are spaced evenly as shown



Window-to-Track Coupler Installation Guide

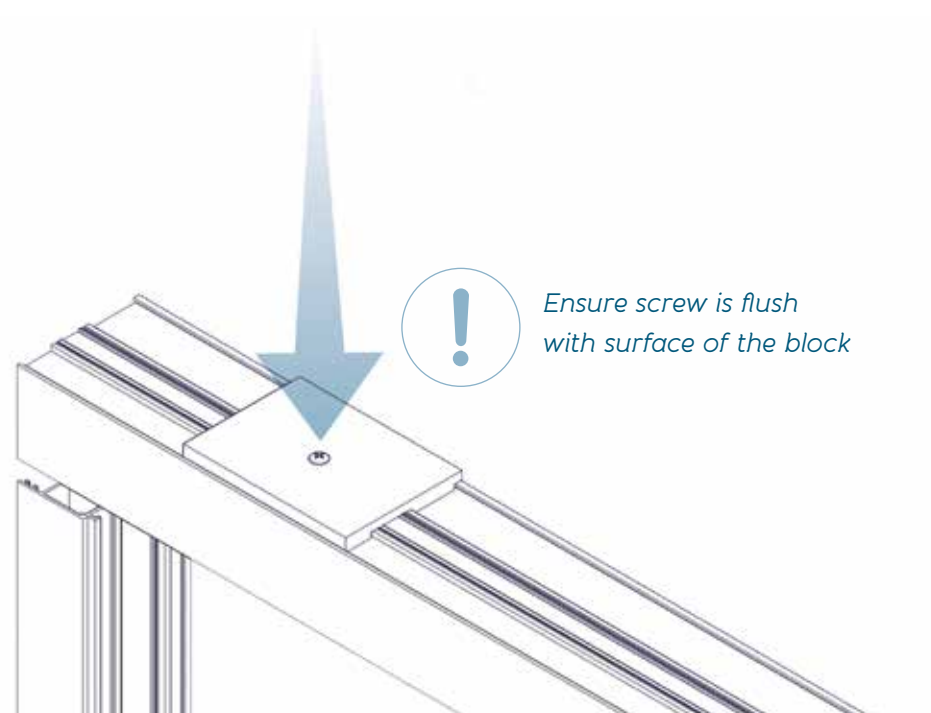
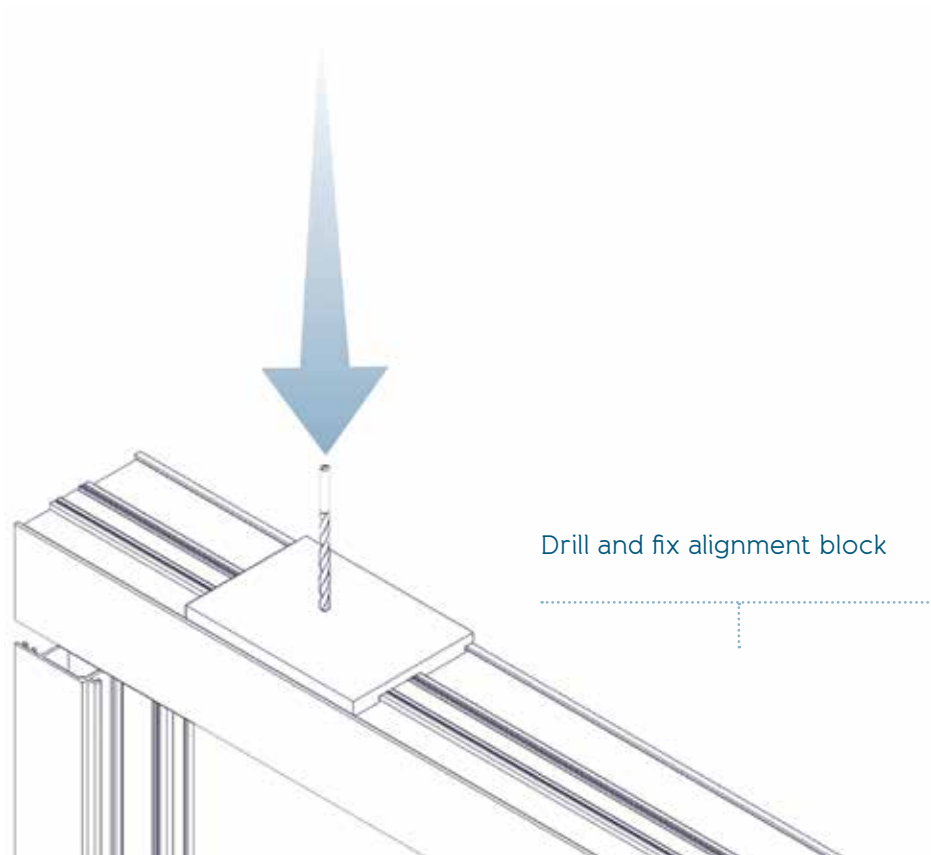

Install window above the door using clamps/
windbags to secure into position

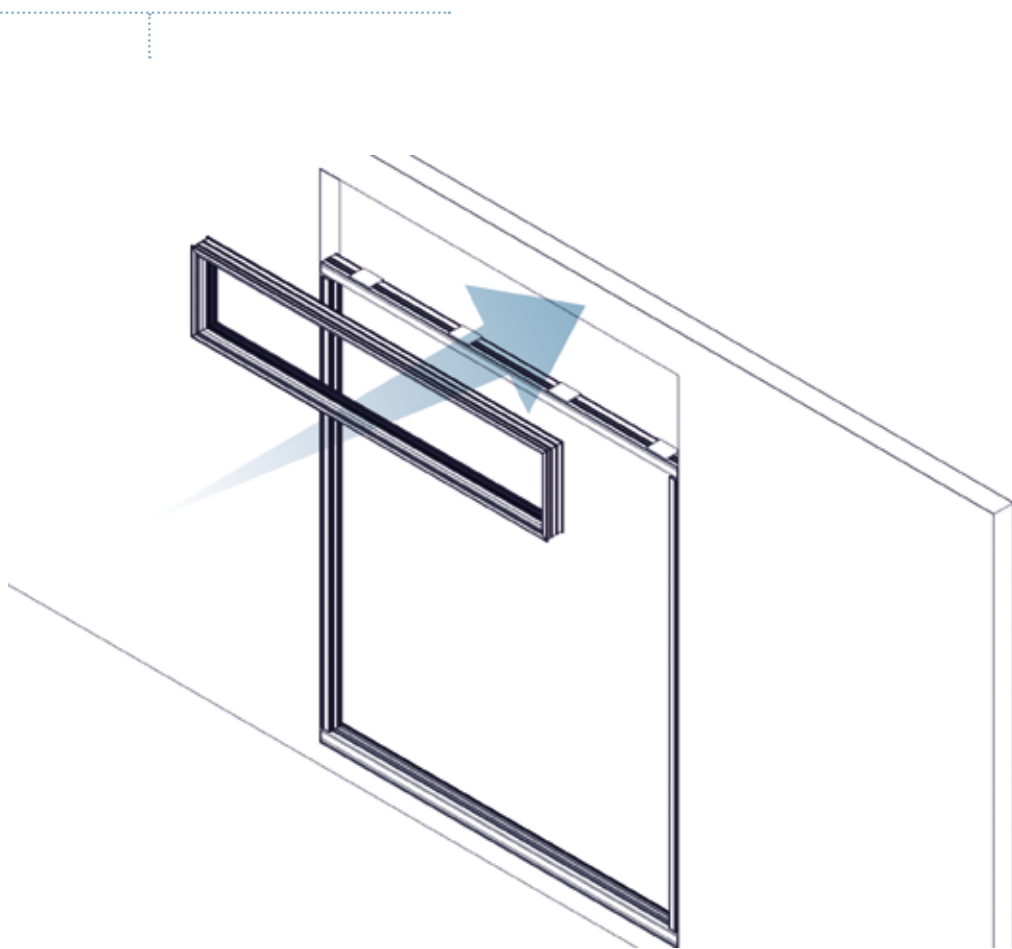

Window-to-Track Coupler Installation Guide

Pre-drill the frame with a 3mm long series drill bit as shown for every alignment block used

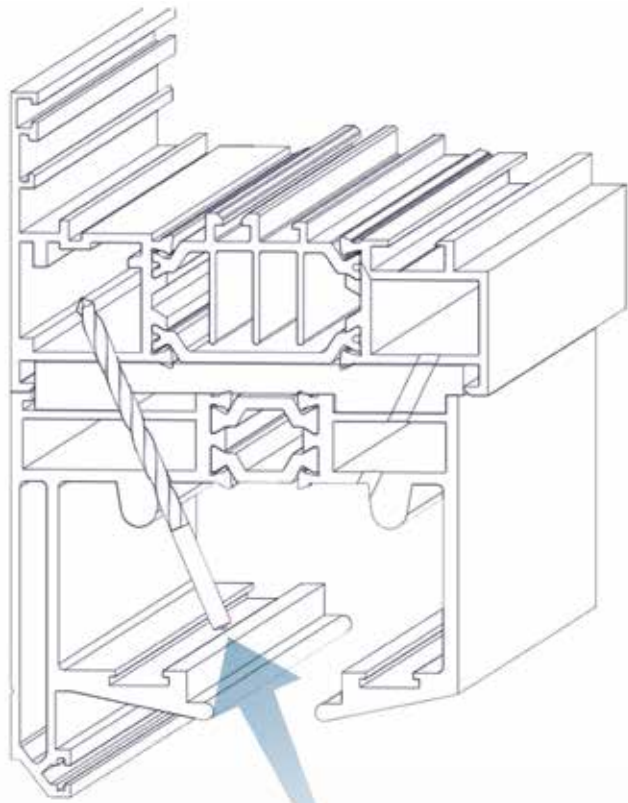

Do not drill into the window cavity

Using screws supplied, fix the track to the window frame

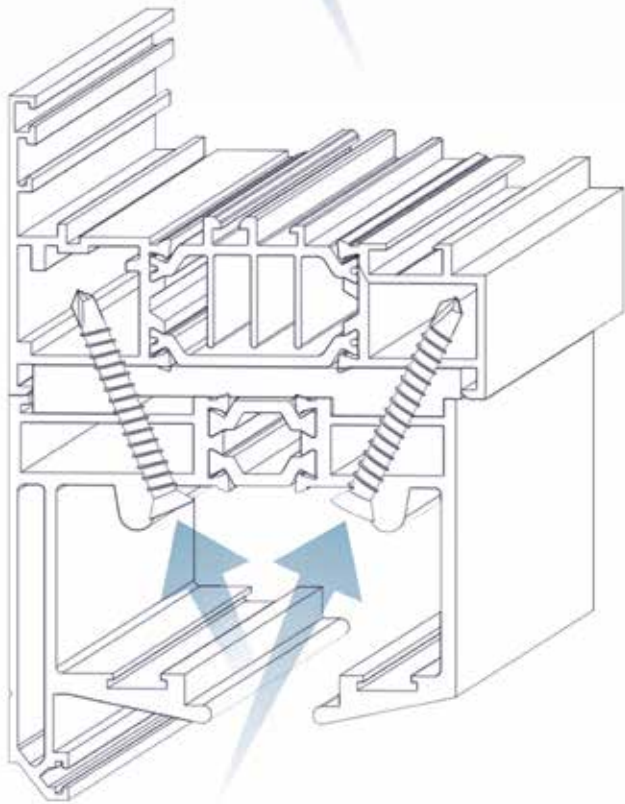

Window-to-Track Coupler Installation Guide

Install door sash,
window and glass
as described in the
Installation Guide

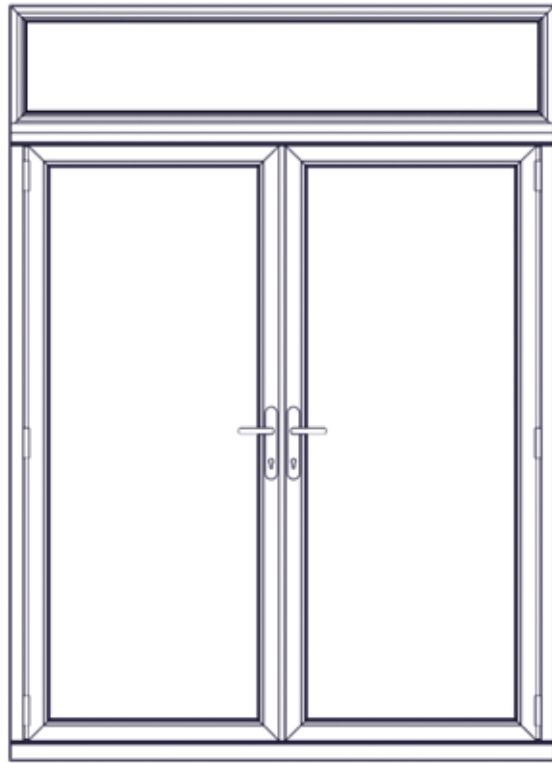

Silicone the joint between
the track and window
frame to ensure the joint is
completely weatherproof



Inside



Outside

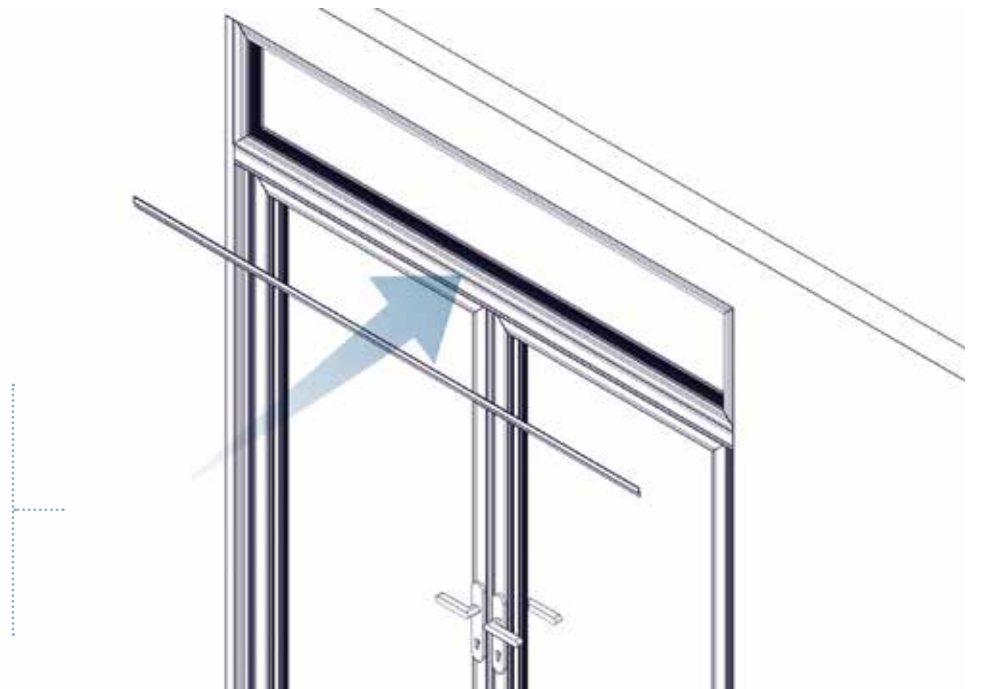

Cut and fit supplied trim
inside (flat) and out (step)

Glazing Bar Installation Guide

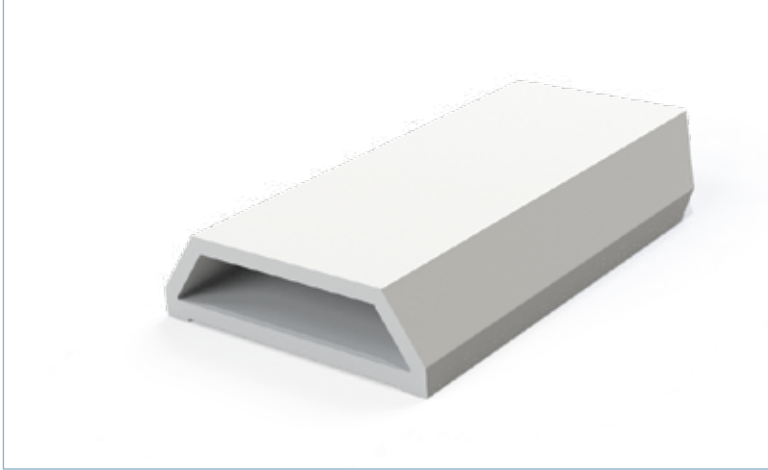

NB: The glazing bars are supplied as 10m bar lengths (2x5m) with 13m tape. The tape will need to be bonded to the lengths of the bar.

1. Once glass is fully installed, ensure the glass is clean. It is recommended to use a saline solution or glass primer.

2. Measure the sash, and using the approximate deductions from the offset table, cut the bars to length with the appropriate angles.

Note: All deductions are oversize to reduce wastage. Bars will need to be trimmed to ensure a seamless joint.

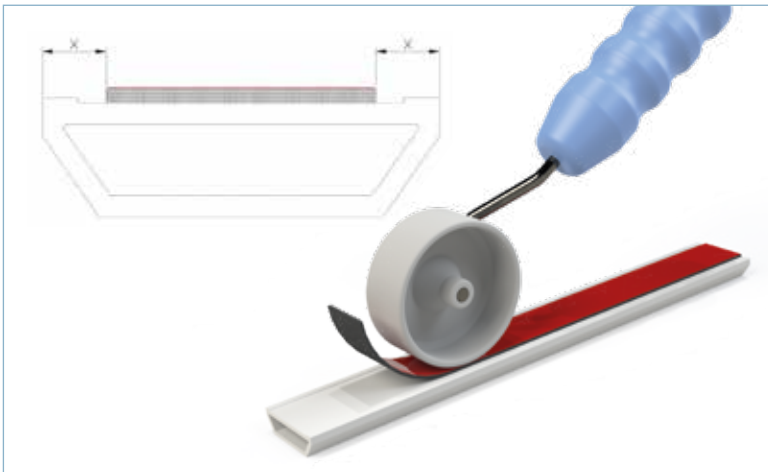

3. Clean the underside of the glazing bar using a saline solution or primer.

4. Place tape on the underside of the glazing bar, ensuring it remains central along the bar. It is recommended that a roller is used for this to ensure strongest bond.

5. Before removing red backing, offer the bars up to the glass and check for size, trim as required.

6. Remove red backing of the tape and press bar firmly onto the glass.

Note: deductions are all approximate and are given as a guideline, final trimming should ensure a snug fit.

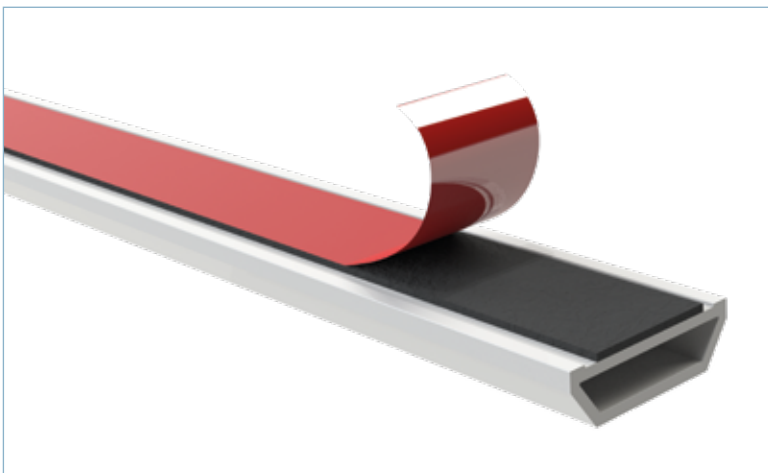

Glazing Bar Door Offsets

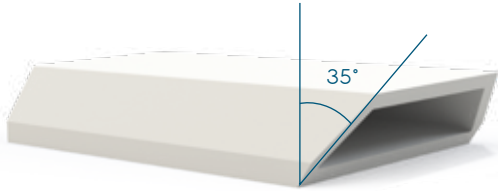

Full lengths	Cut Angle	Approximate Deduction
Rebate to Rebate	45°	X to X - 143mm
28mm Bead	35°	X to X - 151mm

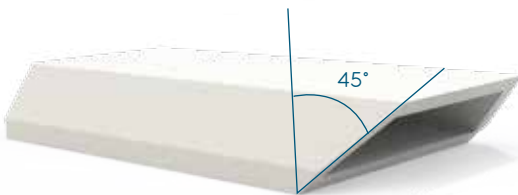

Crossover	Cut Angle	Approximate Deduction
Bar to Bar	35°	Z to Z - 25mm
Rebate to Bar	45° + 35°	X to Z - 84mm
28mm Bead to Bar	45° + 35°	X to Z - 88mm

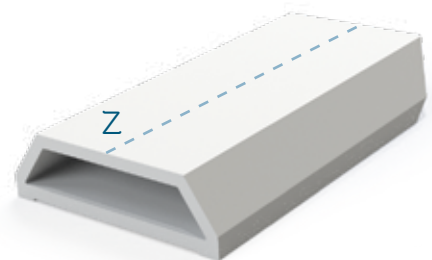
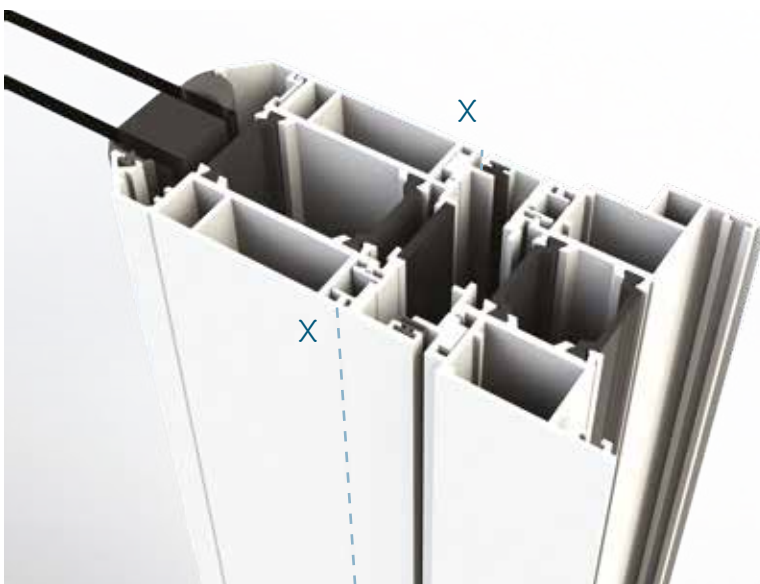
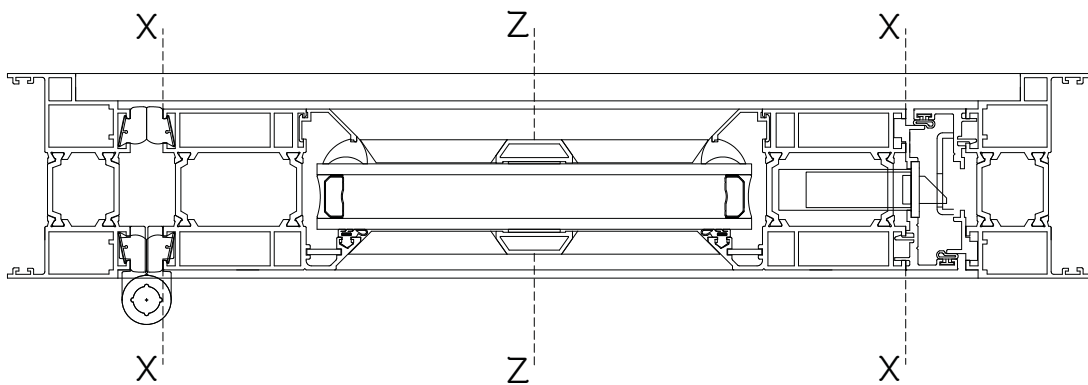

Finger Pull Installation Guide

To be fitted on open-in even door sets only.

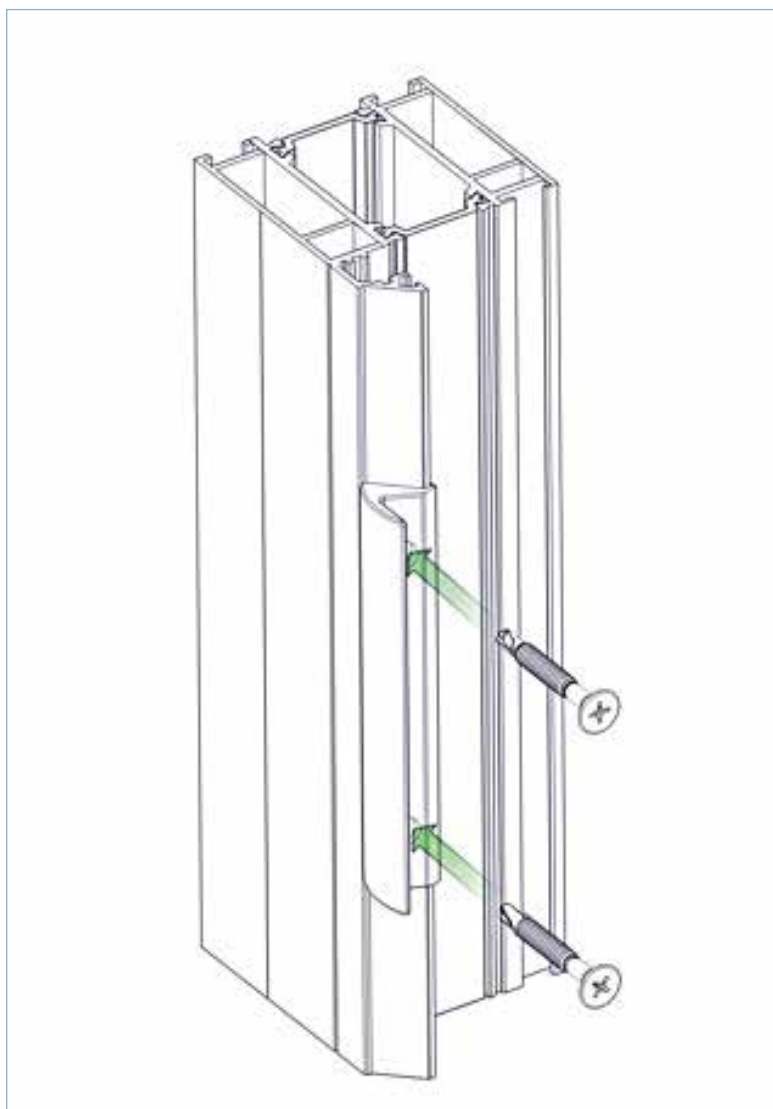

1. Fit the handle to the sash rebate furthest from the mullion on the last door on the even door set.
2. Position the handle on the sash rebate so that the centre is 1020mm from the bottom of the sash and fix as shown below using two 3.9 x 16mm zinc coated self-drilling screws.

NB: It is recommended that the glass be removed before installation to avoid shattering it.



Accreditations...

At Origin, we pride ourselves on providing best quality products backed by best levels of service and efficiency. Put simply, our aim is to continuously learn, evolve and improve.

We are well known for having rigorously high standards in everything that we do. We're also known for innovation, but we never want to settle: if there's a way that we could do something better, we will find it.

This ethos has been instilled throughout Origin. Whether it's a process, product offering or even the company's sustainability, we have created a culture that encourages continuous improvement.

To demonstrate our commitment and as a way of measuring our performance, we work towards gaining certain prestigious accreditations. Our achievements show a strong moral and ethical intent in how we operate and how we try to do things the best way, not because we are told to do so, but because we think it is the right thing to do.

ISO 9001 – Quality Management...

ISO 9001 is an international standard that assesses a company's quality management system. Having first achieved it in 2013, the fact that we still are certified means that we have a track record of consistently providing products and services that meet both customer and regulatory requirements.

It's something that we take very seriously and its influence is integrated into every process.

Key areas of this include:

Product quality – To ensure a product's overall manufacture is flawless, we have checks in place to guarantee you the best quality. A few examples are:

- Supply chain – an inspection at the point of delivery and before going into manufacturing. If anything is spotted, it's documented and raised with the supplier.
 - Production – there are quality checks at every station, not only to look over the previous person's work, but to review the quality of the overall build.
 - Equipment – a robust maintenance schedule for machinery and equipment ensures consistency.
 - Pre-delivery – before it is packaged and loaded ready for delivery, there's another thorough check to ensure nothing's happened whilst being moved from station to station.
 - Feedback – as part of our mission to always innovate, whether it's from internal or external stakeholders, feedback is imperative. We are very proactive at bringing this type of information back into the business and learning, as it gives us an opportunity to improve.
-

Accreditations

- Training and development for our employees – meaning we're better at understanding the good, the bad, and what we can do better.



ISO 45001 – Health & Safety Management...

Whether it's through improving homes with our products, or in our workplace, people are at the heart of everything that we do at Origin, so we are very proud to have achieved a triple badge accreditation when we received our latest accolade - ISO 45001.

ISO 45001 recognises our commitment to employee safety, and reduces workplace risks to create a better, safer working condition. We have spent time reviewing all the activities that go on within the offices, manufacturing centres and warehouses, and have created a full risk log which will link up to our current risk assessments. These are fed back so they can be actioned to be rectified or developed into an improved method of operating.

This means that you can buy from our range safe in the knowledge that we are minimising risks as much as we can for optimum safety.



ISO 14001 – Environmental Management...

Now more than ever, we need to be aware of the impact our operations may have on our environment; the legal obligations we must adhere to, and ensuring we are doing things the right way.

The internationally renowned ISO 14001 accreditation measures the environmental management system that we have in place. It's a subject that's very close to our hearts, which is why working towards this standard was an easy decision.

We care about the resources we use for our products – where they come from and where they end up. To add to this, we aim to be zero waste to landfill and have already put into place many positive changes to make this happen. We want our customers to buy from us with a clear conscience and feel that ISO 14001 can prove that Origin is taking responsibility, acting ethically, legally and exercising best practice in all that we do. Our environmental management system covers:

- Waste management and energy targets – to reduce our consumption and impact on the environment. Helpful hints, tips and reminders are prompted to all staff regularly, so that they can join us in our goal and see how small changes to their work practices can have a big impact.
- Product design and lifecycle – recyclability and sustainability are a design priority for us.
- Supply chain – choosing suppliers that are aligned with our ethos and vision. This is applicable not only when bringing on new suppliers, but also working with existing ones to better their carbon footprint – whether that's minimising packaging, reusing or even our drivers picking up the materials on their routes, rather than a supplier sending their own fleet, we are constantly reviewing how we can improve.



Secured by Design...

Secured by Design (SBD) is a national, police-backed standard, associated with security and levels of performance for weather, operation and quality on domestic properties. The flagship UK police initiative was originally introduced to help 'design out' crime through the use of high-quality, innovative products and market-leading processes.

It recognises that our doors and windows have not only been tested to the required security standards, but that they also adhere to the rigorous test standards required by the police.

This independent certification involves initial testing of the products and regular re-tests, as well as inspections of our manufacturing and production facilities, to ensure the correct processes are maintained constantly over time, providing more secure and reliable products.

In order to be able to apply, we first needed to achieve:

1. PAS 24 (Enhanced Security)
2. BS EN 6375 Part 1 (Weathertightness)
3. BS EN 6375 Part 2 (Operational and Strength Characteristics)
4. BS EN 6375 Part 3 (Basic Security)
5. ISO 9001 (Quality Management)

We're proud to say that our products passed every one and SBD, so you can feel secure by choosing Origin.



PAS 24: 2016...

This is your guarantee that the door sets and windows that we manufacture deliver the right level of security for the buildings they are intended to be part of.

Like most British Standards, PAS 24: 2016 is a minimum standard, and it is either a pass or fail test. There isn't a performance scale for those that are more or less secure, so some of the products that pass will be stronger than the minimum requirement. That's why we have become Secured by Design accredited. Because it's a voluntary scheme, we feel it demonstrates our commitment to the security and overall performance of our products.

Contact

Accounts

t 08448 802 371 or 01494 416 895 **e** Finance@origin-global.com

Marketing

t 08448 802 374 or 01494 416 897 **e** Marketing@origin-global.com

Sales Operations

t 0808 168 5816 or 01494 686 868 **e** OrdersNorth@origin-global.com

e OrdersSouth@origin-global.com

Fleet and Logistics

t 08448 802 378 or 01494 416 898 **e** Logistics@origin-global.com

origin
DOORS AND WINDOWS

Origin Global HQ, Stuart House, Castle Estate,
Coronation Road, High Wycombe
Buckinghamshire, HP12 3TA

t 0808 168 5816
e enquiry@origin-global.com
w www.origin-global.com

