

Bardoline

Fixing Guide



Bardoline

Easy to use tile strip roofing system

Bardoline is easy to handle and so simple to fix and is now also available in economic US20 trade quality.

This design guide sets out the correct fixing method and illustrates how Bardoline accessories can be used to provide simple solutions to meet your requirements.

The result will be a tough, low maintenance roof covering that combines outstanding aesthetic appeal with proven weathering performance.

Bardoline Material Composition

Bardoline is manufactured from high quality materials, using the latest production technology in compliance with ISO 9002 using the highest quality materials.

1. *Ceramicised granules: high temperature process vitrifies the colour pigments providing assured colour stability, Ext. S.AA fire resistance and UV protection.*
2. *Asphalt: specially formulated oxidised asphalt for stability in fluctuating temperatures.*
3. *Pre-impregnated 125g/m² bonded glass fibre mat: guarantees outstanding mechanical resistance.*
4. *Heat sensitive adhesive strip to bond the tile tabs to the course above.*
5. *Silicon sand: under surface finish to the tile strip.*

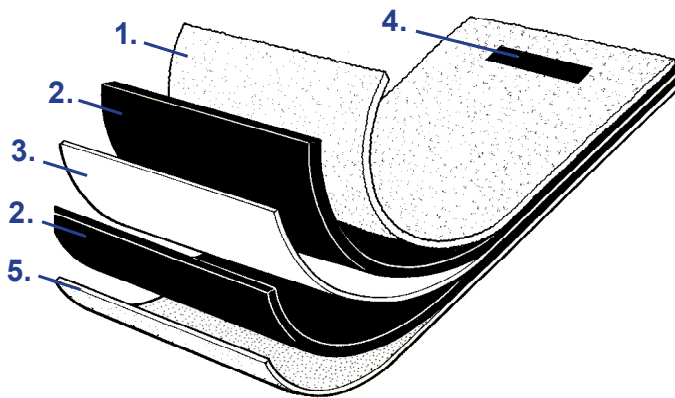

Durability:

Bardoline guarantees against manufacturing faults for the first 15 years. Under normal conditions it will give an effective life in excess of 20 years.

It is rot proof and can be used in coastal and areas of high pollution.

Trade quality US20 shingles have an 8 year guarantee against manufacturing defects.

Bardoline Material Specification

Rectangular

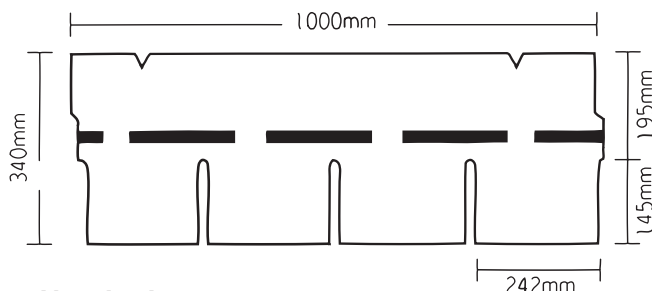

Nominal Thickness	3.1mm
Weight	10.5kg/m ²
Package	No of tiles per pack 21
	Effective surface area 3.05m ²

US20

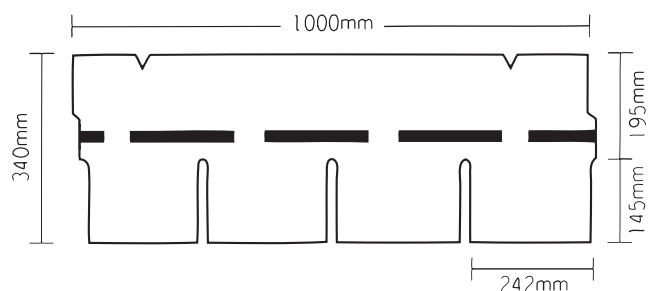

Nominal Thickness	3.0 mm
Weight	9.4kg/m ²
Package	No of tiles per pack 24
	Effective surface area 3.5m ²



Preparation Of Decking

Timber Decking

A fully supporting rigid deck must be provided below the Bardoline. Any irregularity in the decking will be apparent through the tile strips. The roof should be constructed in accordance with relevant Building Regulations and Codes of Practice, with all timber pre-treated with preservatives.

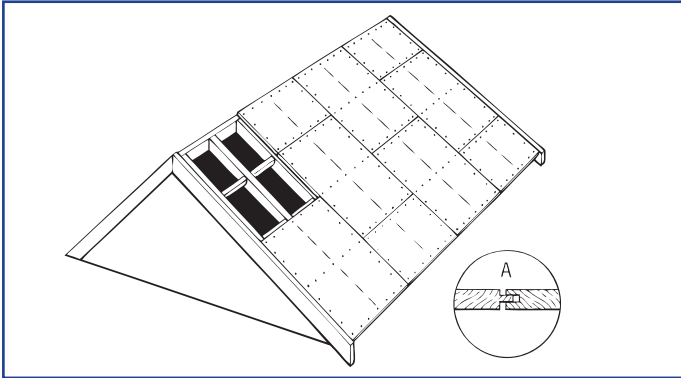

Exterior quality plywood 19mm board is the preferred decking for Bardoline; it should be fully supported on at least three rafters at 600mm centres and laid in a broken bond pattern. If close boarding is used it should be a minimum of 15mm thick and should be interlocking (A) to avoid movement distortion in the decking.

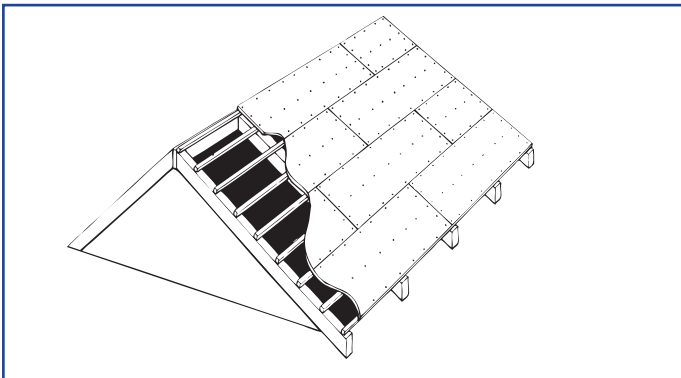

A 12mm plywood decking can also be utilised but should be laid in a broken bond pattern on purlins set at a maximum of 450mm centres.
Note: Standard 19mm large headed clout nails used to fix Bardoline will penetrate a 12mm thick board.

Note:

Caution

Covering of roofs can be hazardous. All work must be carried out with due regard to health and safety regulations.

Maintenance:

To ensure long life the roof should be cleaned regularly of leaves and debris, as leaf mould can reduce the effective life of the product. Also check that tree and shrub branches are not in contact with the surface of the roof; as wind generated movement can cause surface damage to the product.

Concrete Decks

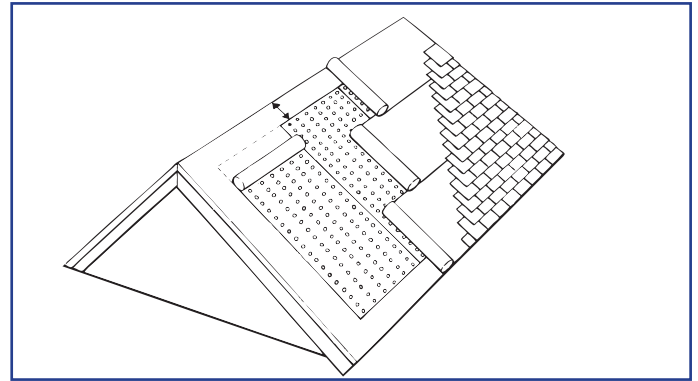

Clean and level deck and then apply bituminous primer. Overlay with multi vent membrane, (not laid within 300mm of abutments). Apply Bituline 4mm APP bonding membrane. Refer to fixing detail 19 for Bardoline fixing instructions.

Oversheating System

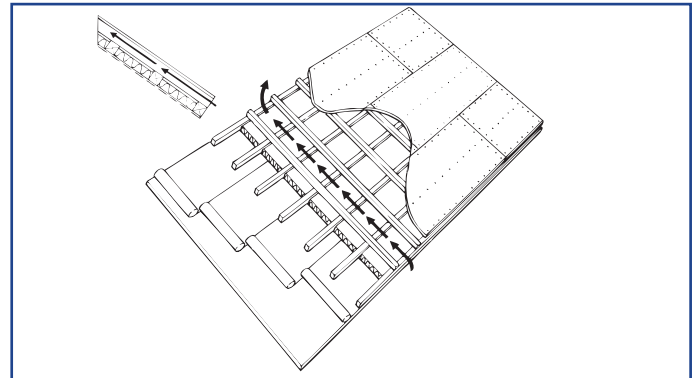

The light weight of Bardoline makes it ideal for overheating existing deteriorated pitched roofs. Clean and level the existing surface, lay Ondutiss underslating membrane with 100mm laps. Fix 50mm treated counter battens at 450mm centres parallel to eaves; lay suitable insulation between purlins. Overlay support battens at 450mm centres, and overlay with 12mm exterior plywood decking to which the Bardoline is then fixed. Note: Allow a 60mm ventilation channel between the decking and insulation. Contact the insulation manufacturer for advice on the fixing requirements.



Bardoline Roof Design

Careful preparation and good roof design incorporating provision for ventilation and insulation will avoid weathering and performance problems. It is essential therefore that Bardoline should be laid on a roof that is well designed and constructed in accordance with relevant building standards and codes of practice.

Ventilation

It is essential to incorporate adequate ventilation into a building. The requirements are set out in B.S.5250: 1989 and must be adhered to.

The examples illustrated are for cold roof construction (Fig.A) with vapour barrier and insulation at ceiling level, and insulated pitched roof construction (Fig.B) with a vented 60mm gap above the insulation and vapour barrier. In both cases if the roof span is greater than 12 metres it is recommended that a roof ventilator is used mid span.

Roof pitches less than 15°

Low level ventilation not less than 25000mm² per linear metre.

Roof pitches greater than 15°

Low level ventilation not less than 10000mm² per linear metre. High-level ventilation in both cases not less than 5000mm² per linear metre.

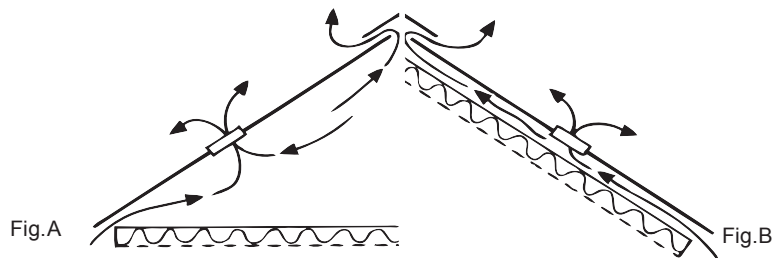

Roof Underlay

Bardoline should be laid on Ondutiss underslators membrane on roofs below 22°, with 100mm side and end laps. It is also recommended for use in exposed areas.

Accessories and Bardoline Colours

A comprehensive range of accessories are available as follows:

- Eaves tray**
- Verge trim**
- Ridge ventilator**
- Inline roof ventilators**
- Roof window**
- Ondutiss underslators membrane**
- Bardoline nails**

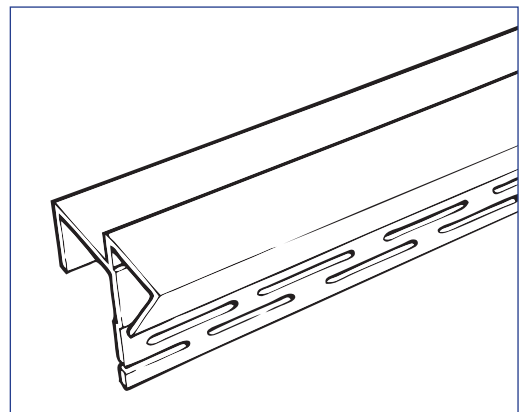

Bardoline is manufactured in a range of colours. Details of colour availability in this country can be obtained from our Sales department and can also be found in the Bardoline sales leaflet.

For information on accessory availability and supply please contact the Sales office.

Note: Although great care is taken to ensure consistency, slight variations in colour can occur during manufacture and it is therefore advisable not to mix the tile strips from different packs during fixing.



Fixing Details

Fixing Bardoline is easy, just follow these instructions to ensure a professional result.

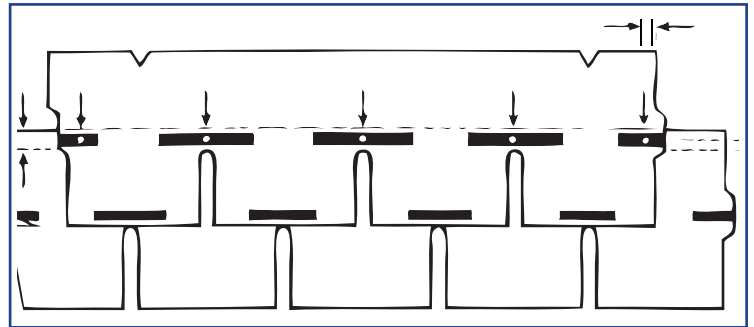
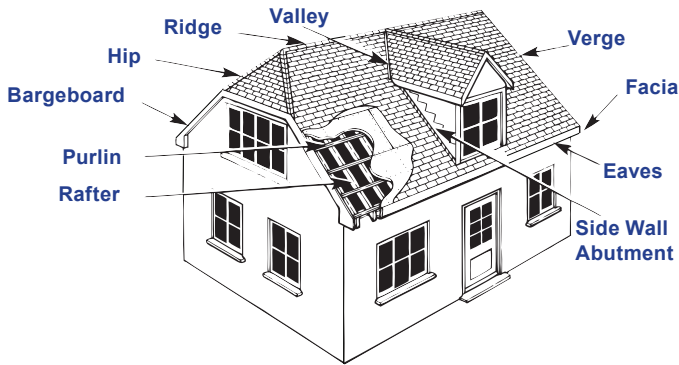

1. Mechanical Fixings

Fix using five 20mm large headed galvanised clout nails per tile strip. Nail through strip centre band and into the top edge of the lower course. Fix nails straight and flush with strip surface.

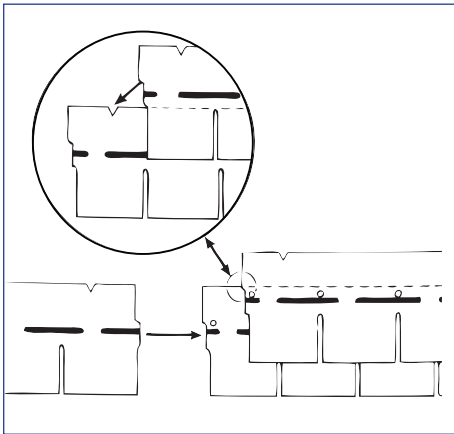

2. Tile Strip Alignment

Interlocking side tags provide horizontal alignment; guide slots are cut into the top edge of the tile strip, which when opened form a slot into which the next course is engaged for vertical alignment.

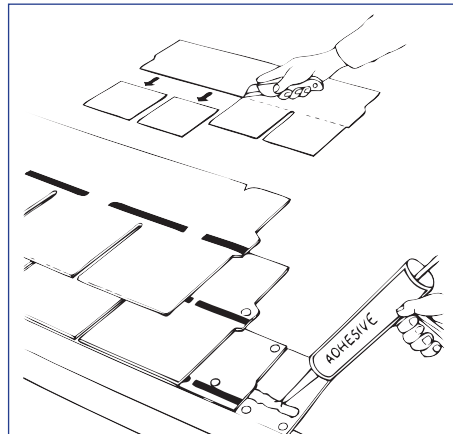

3. Eaves Course

Nail plastic eaves trays in position with 200mm end lap. Prepare base course by removing tile tabs and nail in position on adhesive strip allowing 6mm overlap at fascia. The eaves course is then bonded to the adhesive tabs of the base course.

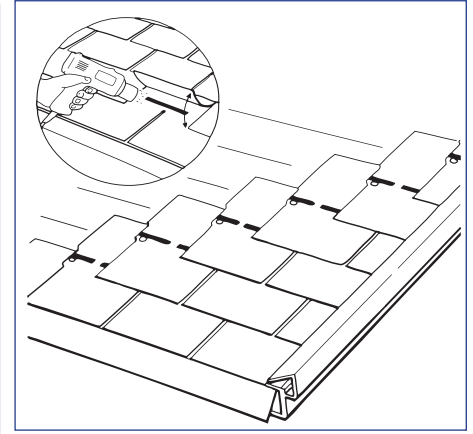

4. Laying Bardoline

Lay the tile strips diagonally, heat the bitumen bonding strip on the lower course and compress upper tile tab to consolidate joint. On completion check the tile bonding, use adhesive to reinforce laps as required.

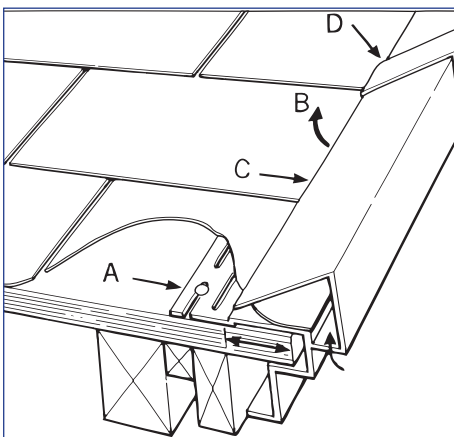

5. Preformed Verge Trim

Allow 25mm decking overhang over fascia line. Nail dry verge trim to decking (A). Lift cover strip (B) and slide into position (C). Use connectors to join verge trims (D).

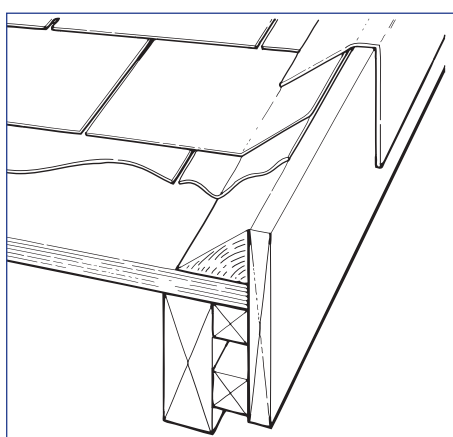

6. Fabricated Verge Trim

Fix timber-tilting fillet to raised bargeboard. Cut and form Bardoline strips on adhesive sealant up to the verge. Cap verge either with a preformed metal flashing, or use Bardoline ridge tiles.

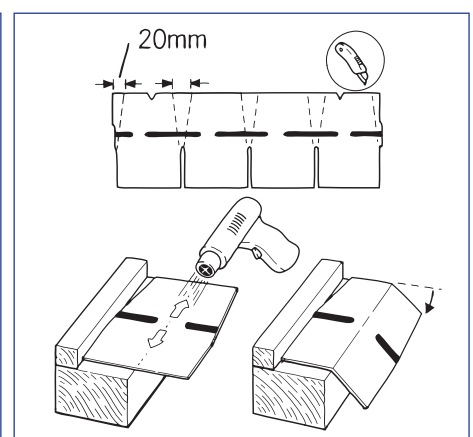

7. Hip & Ridge Tiles

Cut each strip into four pieces, trimming the tile back 20mm from the top edge of the tile strip. Gently heat and bend to form tiles. Lay tiles opposite end of the roof from prevailing wind.



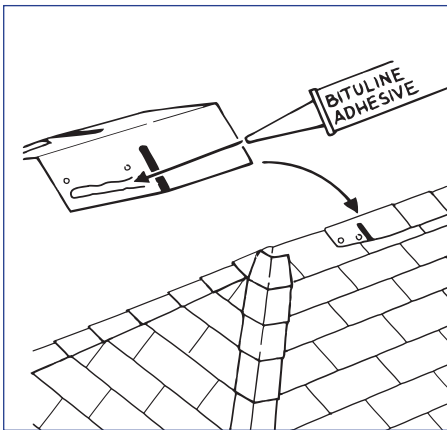

8. Hip & Ridge Fixing

The tile tab forms the exposed area of the ridge tile; lay on adhesive strip and nail centre lap section. After fixing, check bonding and consolidate lap as required with a gentle application of heat.

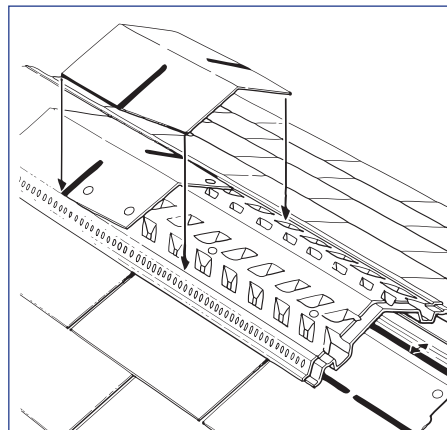

9. Preformed Ventilated Ridge

Provide 25mm gap in decking at ridge and lay tile strips to ridge, Lap and fix ridge unit by nailing through designated line. Overlay with Bardoline ridge tiles fixed as previously described.

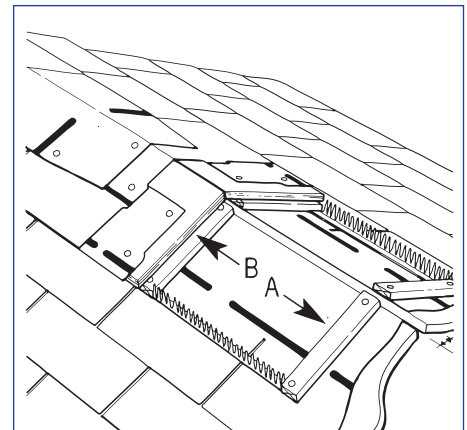

10. Ventilated Ridge

Prepare ridge as Fig. 9. Nail 12x150mm support battens (A) at 200mm centres. Fix ventilator comb and overlay with 12mm plywood raised ridge (B), allowing a 12mm overhang at ridge eaves. Overlay with Bardoline strips/ridges.

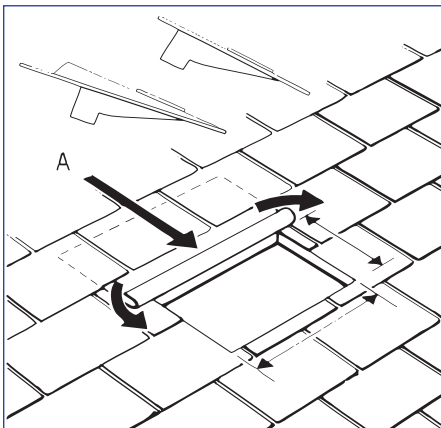

11. In-Line Ventilator

Select the correct ventilator to suit roof pitch. Cut hole in decking and form a well in the Ondutiss (A) under tile strip above.

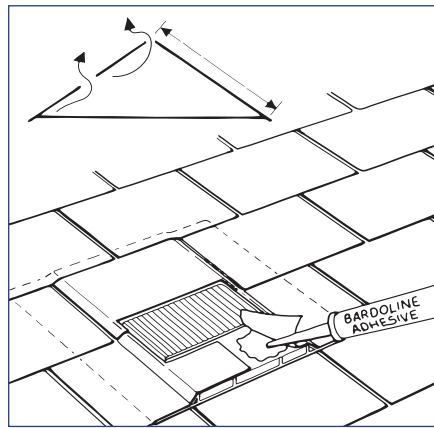

12. In-Line Ventilator

Position and fix ventilator by nailing apron. Cut and overlay Bardoline tile strips using adhesive to bond onto ventilator. Connectors are available to connect to soil vent pipes.

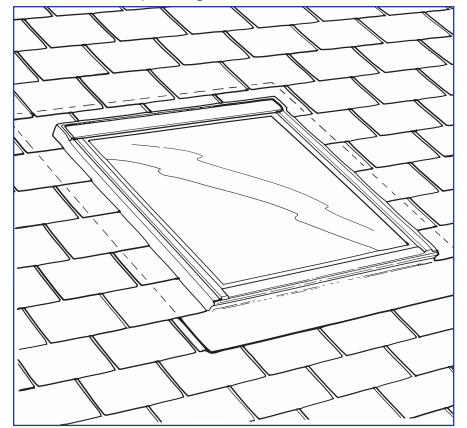

13. Roof Windows

Roof windows are easily fitted within a Bardoline roof using the correct shingle/ roof window flashing kit. Consult the window supplier for details.

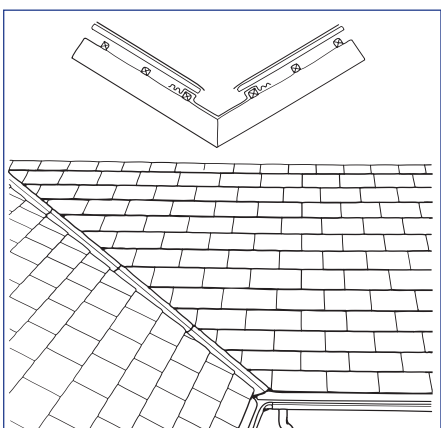

14. Preformed Valley Lining

Proprietary valley linings can be easily incorporated into decked roof construction. Finish exposed edge of decking with trimmed eaves trays. Fix Bardoline with a 6mm overhang into the valley.

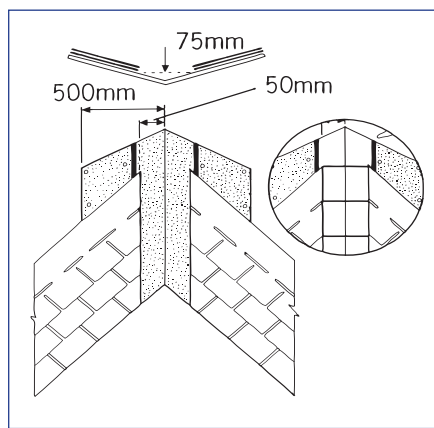

15. Lined Valley Lining

Use high performance mineral surfaced membrane to line valley. Fix tile strips to valley line. Alternatively lay ridge pieces on membrane and overlap strips, sealing edges with sealant adhesive.

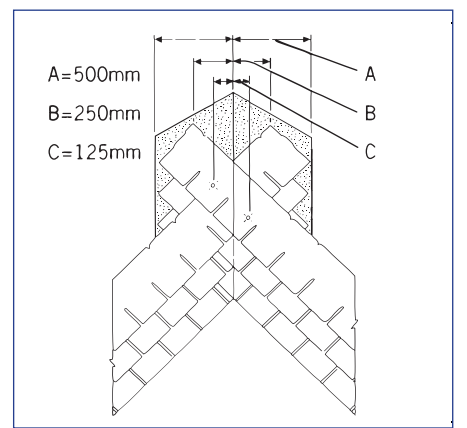

16. Lapped Valley Lining

Line the valley base with Ondutiss underlay, then lap alternative courses of tile strips over it. Mechanical fixings should not be made within 125mm of valley base.



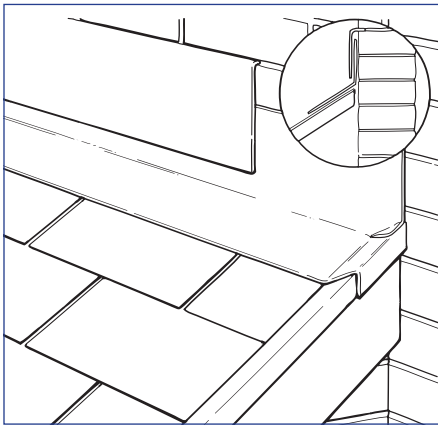

17. Side Wall Abutment

Gently heat tile strip and form 75mm upstand to wall abutment. Alternatively use 75x125mm metal soaker flashings and use adhesive to bond tile strips. Finish with a separate cover flashing.

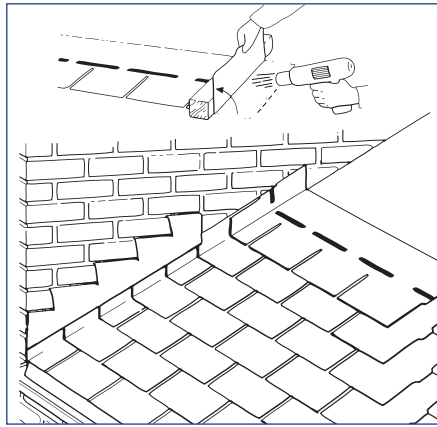

18. End Wall Abutment

Lay Bardoline tile strips to wall abutment. Fabricate and fix a metal abutment flashing with 125mm cover to the tile strips and 75mm upstand. Finish with separate cover flashing.

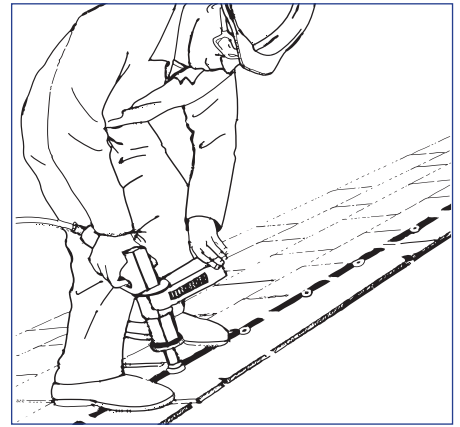

19. Fixing To Concrete Deck

Lay tile strips in accordance with fixing specifications, substituting proprietary gun applied fixings into concrete with at least 10mm diameter heads for standard Bardoline nails.

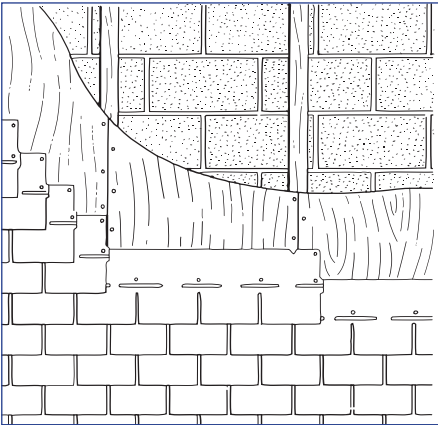

20. Vertical Cladding

Form a studded plywood partition. Fix the tile strips as per roofing specification, but with an additional line of nail fixings at the top of each strip.



Caution:

Covering of roofs can be hazardous. All work must be carried out with due regard to health and safety regulations.

Maintenance:

To ensure long life the roof should be cleaned regularly of leaves and debris, as leaf mould can reduce the effective life of the product. Also check that tree and shrub branches are not in contact with the surface of the roof; as wind generated movement can cause surface damage to the product.

Bardoline Systems Products & Accessories

Comprehensive literature is available giving full specifications of Bardoline Tile Strips and the range of accessories. Contact our sales department for assistance with your roofing project.

www. **onduline** .net

Onduline Building Products Ltd.

Eardley House, 182-184 Campden Hill Road,
Kensington, London. W8 7AS

E-mail: enquiries@onduline.net

www.onduline.net

Telephone: 020 7727 0533

Fax: 020 7792 1390

Bardoline is produced in accordance with European standards EN544, ISO 9001 and ISO 14001.



DECLARATION OF CONFORMITY
Manufactured in compliance with European Technical Directives
Harmonized EN544 & EN545 in relation to the Construction Products
Regulation (EU) 2018/1105 and other applicable standards.
EN544 & EN545
CE Marked in accordance with EN544 & EN545
CE Marked in accordance with EN544 & EN545

Note:

At the time of writing Bardoline US20 grade shingles are not covered within the existing BBA certification.

