



AXUS

Circular Short Cased Axial Flow Fans Installation and Maintenance

1.0 Introduction

The Nuaire Short Cased Axial Fan range is produced in a range of sizes from 250mm to 1600mm diameter.

Cases are manufactured from various materials such as pre-galvanised steel, stainless steel or hot dipped galvanised steel. Impellers are selected to meet the specific performance and are available in a variety of materials to ensure suitability for the application.

Units are available for single and three phase supply.

2.0 Handling and Storage

The fan impeller is carefully balanced prior to despatch and great care must be exercised when handling the unit.

This will ensure that the case is not damaged or distorted, causing the impeller to foul against the casing. The fan should be stored on a flat surface and the impeller rotated at regular intervals.

Figure 1. Correct method of lifting/removing from a pallet.

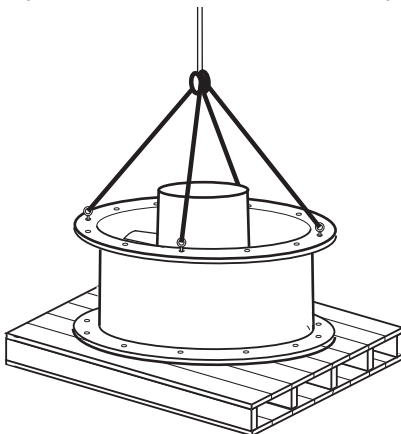
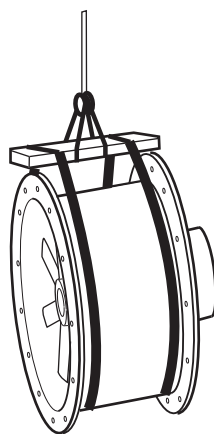

Figure 2. Moving/positioning unit to application using a spreader.



3.0 Installation

Installation must be carried out by competent personnel in accordance with good industry practice, the appropriate authority and in conformance with all statutory and governing regulations.

IMPORTANT

Any damages or deviations should be immediately reported to Nuaire quoting the order/Arc number and product details, detailed on the product rating label.

Prior to installation the impeller should be rotated by hand to ensure free and smooth rotation and that no transit or handling damage has occurred.

General advice

Ensure that impeller and motor are free from obstruction and that all optional accessories such as guards and bell mouths are securely fastened before commencing unit start up.

When operating at low temperatures, ice formation can occur, and suitable prevention should be adopted to avoid ice build up.

Motors

In general motors are totally enclosed, protected to IP55 (Dust and low pressure water jets) and have an integral terminal box. Motors may incorporate drain holes to allow any condensation to escape from the motor casing. **It is essential that drain hole plugs positioned at the lowest point of the motor are removed to allow condensate to drain out of the motor.**

All bearings are pre-packed with grease and sealed for life requiring no further lubrication.

Connection Details

Electrical connections are made directly to the motor terminal box as standard. Check that the voltage on the fan rating label is suitable for your supply. Full load and starting currents are also indicated.

Motors below 4kW are designed for Direct On Line starting whilst 4kW and above are suitable for Direct On Line or Star/Delta starting.

Start Up Procedure

On start up ensure the impeller rotation follows the arrow indicator on the fan casing. Should the direction be incorrect on a three phase unit reverse any two of the supply leads.

Single phase rotational direction is set at the factory and should not be altered. Equipment should be run for approximately 30 minutes to ensure correct operation.

If any fault occurs the equipment should be switched off and not re-started until the fault has been rectified.

Reversing Fans

If the unit is specified as 'reversing fan' care must be taken when designing the control gear to ensure that enough time is allowed for the fan impeller to come to a standstill before switching to the opposite rotation.

4.0 Electrical Installation

IMPORTANT

For good EMC engineering practice, any sensor cables or switched live cables should not be placed within 50mm of other cables or on the same metal cable tray as other cables.

Units are not supplied with electrical isolators, their selection and provision is the responsibility of the installer. Ensure the electrical supply is suitable for the fan and that all wiring, fuse and overload protection etc is appropriately

sized by comparing with the rating plate. Electrical connection is made direct to the motor terminal box. For DOL starting of 4kW and above, 3ph, the final connection must be in DELTA. If a STAR/DELTA starter is to be used connect all six motor terminals to the appropriate terminals of the starter.

IMPORTANT

If motor overheat protection is specified, terminals T1 and T2 must be connected to the fan control circuit. Failure to do this will invalidate the warranty.

5.0 Wiring Connections for Motor

Single phase.

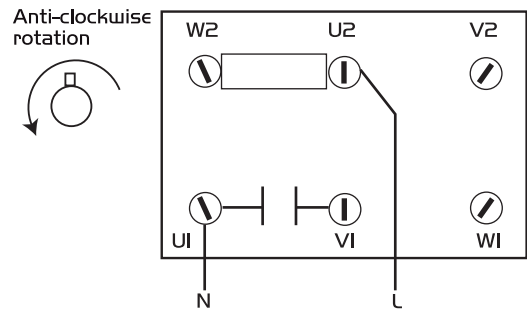
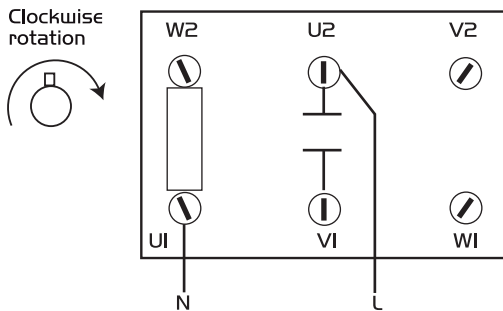

Three phase - up to and including 3kW.

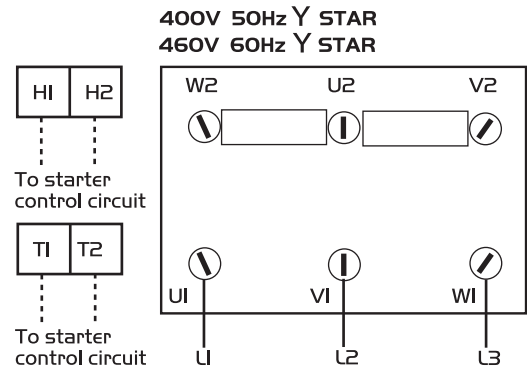
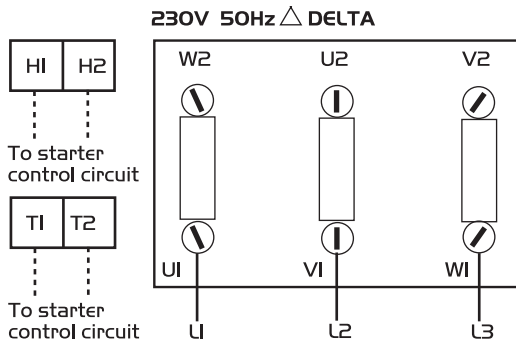

Three phase - 4kW and above.

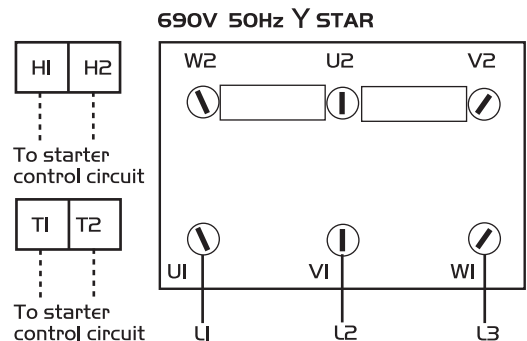
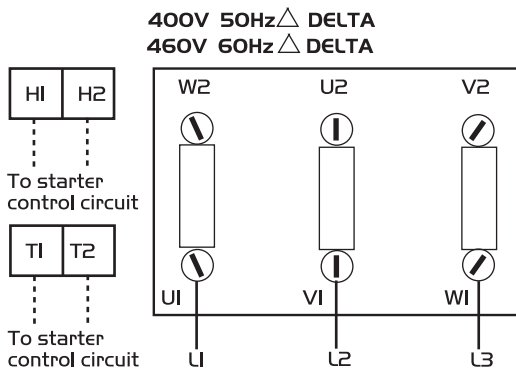

Important. T1 and T2 = Thermistor connections
 HI and H2 = A.C. Heater connections

6.0 Maintenance

IMPORTANT

Isolation - Before commencing inspection or maintenance work make sure that the unit is electrically isolated from the mains supply.

Due to the different periods of operation from the time of installation and varying use, no rigid inspection and maintenance periods can be recommended. We suggest therefore that the inspection, and if necessary cleaning/ bearing check should be carried out at regular intervals of a maximum of six months.

For routine inspection check the tightness of all nuts, keys, grubscrews and endbolts etc. Remove any build up of dirt or dust with a soft brush and ensure that the clearance between the impeller and fan casing has not been compromised.

7.0 Spares

The only components of the fan that could require replacing are the motor or the fan impeller.

When ordering spares please quote the serial number, Order/Arc number, together with a full description of the part.

8.0 Service Enquiries

Nuaire can assist you in all aspects of service. Our Technical Support department will be happy to provide any assistance required,.

Telephone 029 2085 8585
Fax 029 2085 8586



Technical or commercial considerations may, from time to time, make it necessary to alter the design, performance and dimensions of equipment and the right is reserved to make such changes without prior notice.

DECLARATION OF INCORPORATION AND INFORMATION FOR SAFE INSTALLATION, OPERATION AND MAINTENANCE

We declare that the machinery named below is intended to be assembled with other components to constitute a system of machinery. The machinery shall not be put into service until the system has been declared to be in conformity with the provisions of the EC Machinery Directive.

Designation of machinery: AXUS Short Cased Axial Flow Fan
 Machinery Types: AX
 Relevant EC Council Directives: 98/37/EC as amended by 98/79/EC (Machinery Directive)
 Applied Harmonised Standards: BS EN ISO 12100-1, BS EN ISO 12100-2, EN294, EN60204-1, BS EN ISO 9001
 Applied National Standards: BS848 Parts One, Two and Five

Signature of manufacture representatives:

Name:	Position:	Date:
1) C. Biggs 	ical Director	01. 10. 13
2) A. Jones 	Manufacturing Director	01. 10. 13

INFORMATION FOR SAFE INSTALLATION, OPERATION AND MAINTENANCE OF NUAIRE VENTILATION EQUIPMENT

To comply with EC Council Directives 98/37/EC Machinery Directive and 2004/108/EC (EMC).

To be read in conjunction with the relevant Product Documentation (see 2.1)

1.0 GENERAL

1.1 The equipment referred to in this Declaration of Incorporation is supplied by Nuairé to be assembled into a ventilation system which may or may not include additional components.
 The entire system must be considered for safety purposes and it is the responsibility of the installer to ensure that all of the equipment is installed in compliance with the manufacturers recommendations and with due regard to current legislation and codes of practice.

2.0 INFORMATION SUPPLIED WITH THE EQUIPMENT

2.1 Each item of equipment is supplied with a set of documentation which provides the information required for the safe installation and maintenance of the equipment. This may be in the form of a Data sheet and/or Installation and Maintenance instruction.
 2.2 Each unit has a rating plate attached to its outer casing. The rating plate provides essential data relating to the equipment such as serial number, unit code and electrical data. Any further data that may be required will be found in the documentation. If any item is unclear or more information is required, contact Nuairé.
 2.3 Where warning labels or notices are attached to the unit the instructions given must be adhered to.

3.0 TRANSPORTATION, HANDLING AND STORAGE

3.1 Care must be taken at all times to prevent damage to the equipment. Note that shock to the unit may result in the balance of the impeller being affected.
 3.2 When handling the equipment, care should be taken with corners and edges and that the weight distribution within the unit is considered. Lifting gear such as slings or ropes must be arranged so as not to bear on the casing.
 3.3 Equipment stored on site prior to installation should be protected from the weather and steps taken to prevent ingress of contaminants.

4.0 OPERATIONAL LIMITS

4.1 It is important that the specified operational limits for the equipment are adhered to e.g. operational air temperature, air borne contaminants and unit orientation.
 4.2 Where installation accessories are supplied with the specified equipment e.g. wall mounting brackets. They are to be used to support the equipment only. Other system components must have separate provision for support.
 4.3 Flanges and connection spigots are provided for the purpose of joining to duct work systems. They must not be used to support the ductwork.

5.0 INSTALLATION REQUIREMENTS

In addition to the particular requirements given for the individual product, the following general requirements should be noted.

5.1 Where access to any part of equipment which moves, or can become electrically live are not prevented by the equipment panels or by fixed installation detail (eg ducting), then guarding to the appropriate standard must be fitted.
 5.2 The electrical installation of the equipment must comply with the requirements of the relevant local electrical safety regulations.
 5.3 For EMC all control and sensor cables should not be placed within 50mm or on the same metal cable tray as 230V switched live, lighting or power cables and any cables not intended for use with this product.

6.0 COMMISSIONING REQUIREMENTS

6.1 General pre-commissioning checks relevant to safe operation consist of the following:
 Ensure that no foreign bodies are present within the fan or casing.
 Check electrical safety. e.g. Insulation and earthing.
 Check guarding of system.
 Check operation of Isolators/Controls.
 Check fastenings for security.
 6.2 Other commissioning requirements are given in the relevant product documentation.

7.0 OPERATIONAL REQUIREMENTS

7.1 Equipment access panels must be in place at all times during operation of the unit, and must be secured with the original fastenings.
 7.2 If failure of the equipment occurs or is suspected then it should be taken out of service until a competent person can effect repair or examination. (Note that certain ranges of equipment are designed to detect and compensate for fan failure).

8.0 MAINTENANCE REQUIREMENTS

8.1 Specific maintenance requirements are given in the relevant product documentation.
 8.2 It is important that the correct tools are used for the various tasks required.
 8.3 If the access panels are to be removed for any reason the electrical supply to the unit must be isolated.
 8.4 A minimum period of two minutes should be allowed after electrical disconnection before access panels are removed. This will allow the impeller to come to rest.
NB: Care should still be taken however since airflow generated at some other point in the system can cause the impeller to "windmill" even when power is not present.
 8.5 Care should be taken when removing and storing access panels in windy conditions.