



AXUS AX

Circular Long Cased Axial Flow Fans Installation and Maintenance

Introduction

The AXUS range of axial flow fans are designed for 'in duct' applications. Manufactured from galvanised steel they are suitable for in, or out door installation and at any installed angle.

Available for single and three phase supplies.
Case diameters of 250mm to 2000mm.
Unit codes AX25 to AX200.

Impellers have been selected at blade angle settings matched to various motor speeds to perform against the design criteria laid down in our selection catalogue.

Any attempt to adjust or reset impeller blade angles will invalidate warranty.

For full unit description, dimensional, weight and performance details refer to our catalogue. Our comprehensive range of ancillaries and silencers are also listed.

I.O Handling

The fan impeller is carefully balanced and centralised in the fan case, it is therefore essential that great care is exercised when handling the unit. Never pass lifting slings through the impeller (figure 2), check the weight on the rating plate details before attempting to lift and always use a spreader as shown in figure 1.

Figure 1. Correct method of lifting using a spreader.

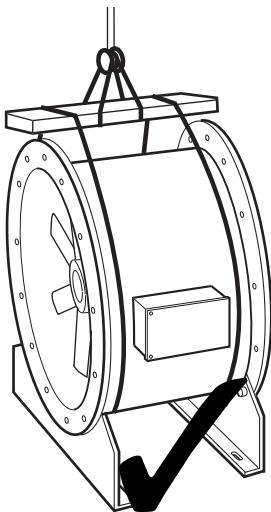
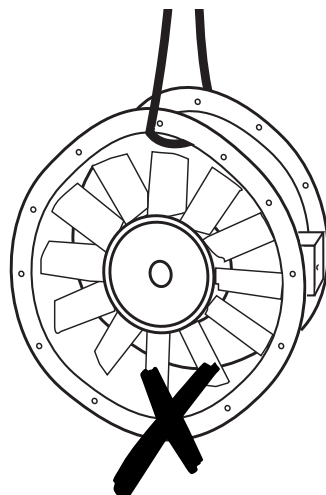

Figure 2. The wrong method of lifting with sling through impeller can cause case distortion.



2.0 Installation and General Advice

Installation must be carried out by competent personnel, in accordance with good industry practice, the appropriate authority and in conformance with all statutory and governing regulations e.g. IEE, CIBSE, COHSE, HVCA, ATEX, BSI & EN standards etc.

If the fan is to be installed in a potentially explosive atmosphere it will have been designed to ATEX-100 directive 94/9/EC and will incorporate motors requiring compatible installation wiring direct to the motor termination box, to complete this installation also follow the guidance advice of data sheet 671216.

Before commencing installation check that all material, including optional ancillaries are available to complete the installation. Every unit is tested and serialised at works and a test certificate produced, the details recorded on the fan side rating plate should also be referred to before handling and installation.

Any damages or deviations should be immediately reported to the seller/supplier/agent quoting the order and product details from the product rating plate.

2.1 Mechanical Installation

Rotate the fan impeller by hand to ensure free and smooth rotation and that no transit or handling damage has occurred, observe the direction of flow/direction of rotation arrow and ensure that:

All optional accessories such as support brackets, attenuators, inlet cones, guards, flexible connectors etc. are assembled to the fan.

The optional support brackets are correctly fitted, at any position around the circumference, but suit the installation plane.

External termination box is accessible to the electrician.

When offering the fan to the ducted system that both inlet and outlet connections are perfectly aligned.

2.2 Horizontal on Floor or Supported from Wall etc

Optional resilient mountings should be attached to the unit mounting brackets at this stage. (See figure 3).

If the unit is supported from a wall, supporting brackets should be used. Position and align the unit with the ductwork in both horizontal and vertical planes and pack height under mounting feet if necessary.

Matching attenuators if required, should be fitted to the fan with any other accessories before installation.

Matching flanges are fixed to the ductwork ends with rivets.

cont. on page 2.

Figure 3. Resilient Mounting 'Floor' fixing.

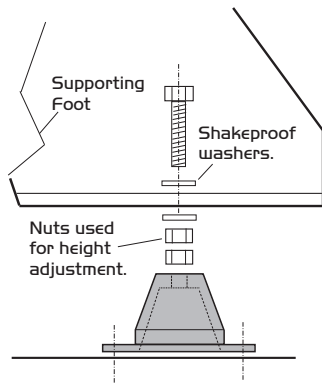
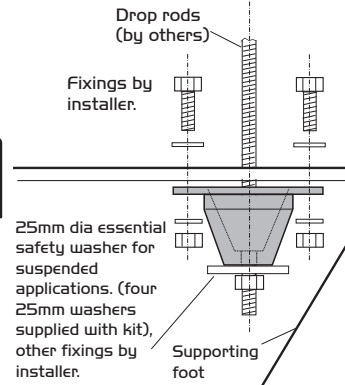

Figure 4. Resilient Mounting 'Suspended' fixing.



AV mounts isolate the fan only. Silencers/backdraught dampers and other "significant mass" accessories should form part of the fixed ductwork after the flexible connection.

2.3 Suspended Horizontally or Vertically

A.V. mountings must be arranged so that they are used in **compression only**. If Resilient Mountings NAV1 to NAV5 are specified the rubber mountings must also remain in compression. The large metal washers must be fitted under the studding nuts on each mounting. (See figure 4).

Other types of A.V. mounts - spring etc are also designed to be used in compression only.

A suspended steel underframe would be necessary to support the unit, (by others) standing on A.V. mountings.

2.4 Ecosmart Control Installation (optional)

The controller must be fitted indoors (an optional outdoor cover can be purchased) and away from water spray and heat source.

The operating range is - 10^o to 35^oC up to 85% relative humidity.

The controller must be fitted to a vertical vibration free wall with appropriate fasteners and for ease of installation the cover should be removed and the casing separated from the base.

If cooling fans are fitted they should be disconnected while installation takes place.

The cable connecting the Ecosmart control and the fan must be a screened power cable, not exceeding 30 metres.

The screening must be earthed at both ends using the special cable glands supplied.

Bridge any break in the screening (e.g. at local isolators) using braided earthing strap.

(Details of Ecosmart controls and wiring connections can be found on pages 4, 5 and 6).

IMPORTANT

Warning - Inverter Speed Control.

An Inverter is used to provide speed control. When the fan is isolated, allow 5 minutes for the capacitors in the inverter to discharge before commencing any work on the unit.

2.5 Electrical Installation

Units are not supplied with electrical isolators, their selection and provision is the responsibility of the installer.

Ensure the electrical supply is suitable for the fan and that all wiring, fuse and overload protection etc is appropriately sized by comparing with the rating plate.

Electrical connection is made direct to the motor termination box on all fans, if explosion proof motors are fitted they will require matched spec' wiring, refer to data sheet 671216 for additional advice.

Wiring connection diagrams; where a starter, frequency inverter or Ecosmart control is used also refer to the relevant control I&M instructions. Bifurcated fans should only be speed controlled by a frequency inverter.

It is essential to note that for all three phase fans of 4KW and above the final connection must be in DELTA.

If a Star/Delta starter is to be used connect all six motor terminals to the appropriate terminals of the starter, if the fan is to be started direct on line (DOL), to a frequency inverter or Nuair's Ecosmart speed control the motor **must be connected in Delta**.

If T1/ T2 are located in the fan terminal block, this is the motor overheat protection device which is Thermistors or Thermostat as specified.

IMPORTANT

For good EMC engineering practice, any sensor cables or switched live cables should not be placed within 50mm of other cables or on the same metal cable tray as other cables.

3.0 Electrical Wiring

SINGLE PHASE UNITS

Single Speed 1 phase

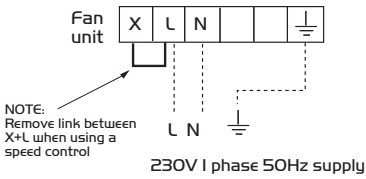

Speed Control, ELECTRONIC 1 phase

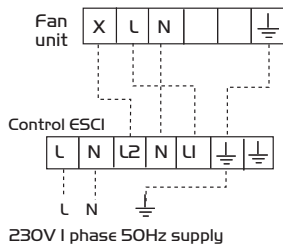

Speed Control, TRANSFORMER 1 phase

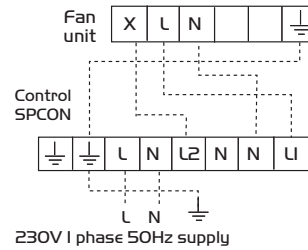

THREE PHASE UNITS

Single Speed 3 phase (below 4kW)

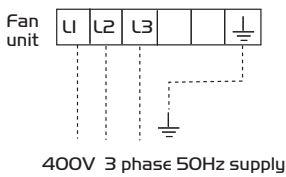

Speed Control, TRANSFORMER 3 phase

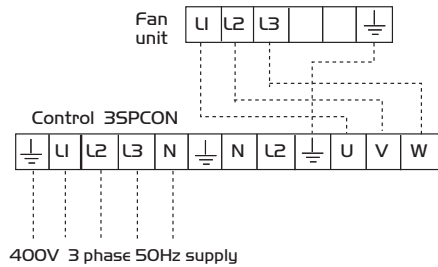

2 SPEED TAP/PAM WOUND MOTORS (D.O.L. starting both speeds)

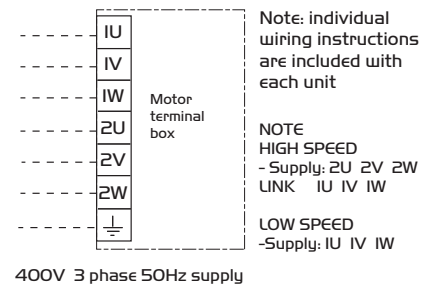

IMPORTANT

For specialist connections not shown always refer to the wiring diagram supplied with the unit. In the event of query or uncertainty contact NUAIRE directly before any connection is made.

3 phase two speed DUAL WOUND MOTOR. Direct on Line starting on both speeds.

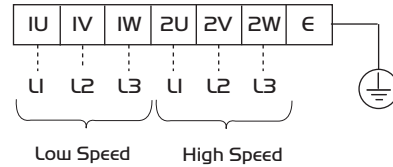

The starter control requires a starter contactor for each speed, these contactors should be mechanically and electrically interlocked so as to prevent both from energising simultaneously.

3 phase for DOL STARTING (3kW and below)

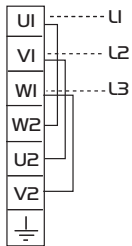

400V 3 phase 50Hz supply

3 phase for connection to a STAR /DELTA STARTER (4kW and above)

Note: For all D.O.L. (Direct On Line) operation or Inverter type Speed Control wire in DELTA

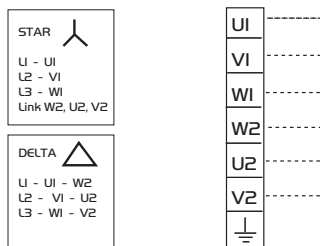

400V 3 phase 50Hz supply

Matched Frequency Inverter

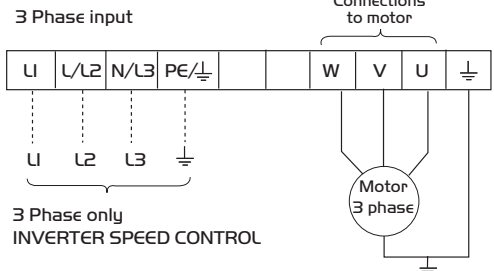

Notes: Total length of motor leads should not exceed 50 metres. If a screened motor cable is used, maximum length should be 25 metres. Consult our Technical Department if you wish to use longer leads. Inverters are configured to suit specific fans and control applications as described on the Customer Order free of charge.

400V 3 phase 50Hz supply

Sections 3.1, 3.2 & 4 are applicable to Ecosmart Control option only.

3.1 Electrical Wiring

The mains power supply to the controller must appropriately sized and installed via a local isolation switch (by others). The isolator must also accommodate the 230V switched live (if used).

The mains supply from the Ecosmart controller to the fan must be appropriately sized, not exceeding 30 metres and must be a screened power cable, earthed at both ends.

A four point glanding plate is formed from the base of the control and in order to maintain EMC compliance, an EMC glanding kit is supplied.

Ecosmart controls and sensors are supplied with 10 metres of data cable plugged at both ends, if used these can now be fitted and plugged in to the low voltage sockets on the Ecosmart control board. **All other low voltage connections i.e. BMS can also be completed.**

IMPORTANT

* Motors of 4kW and above must be connected to Delta Δ

Figure 5.

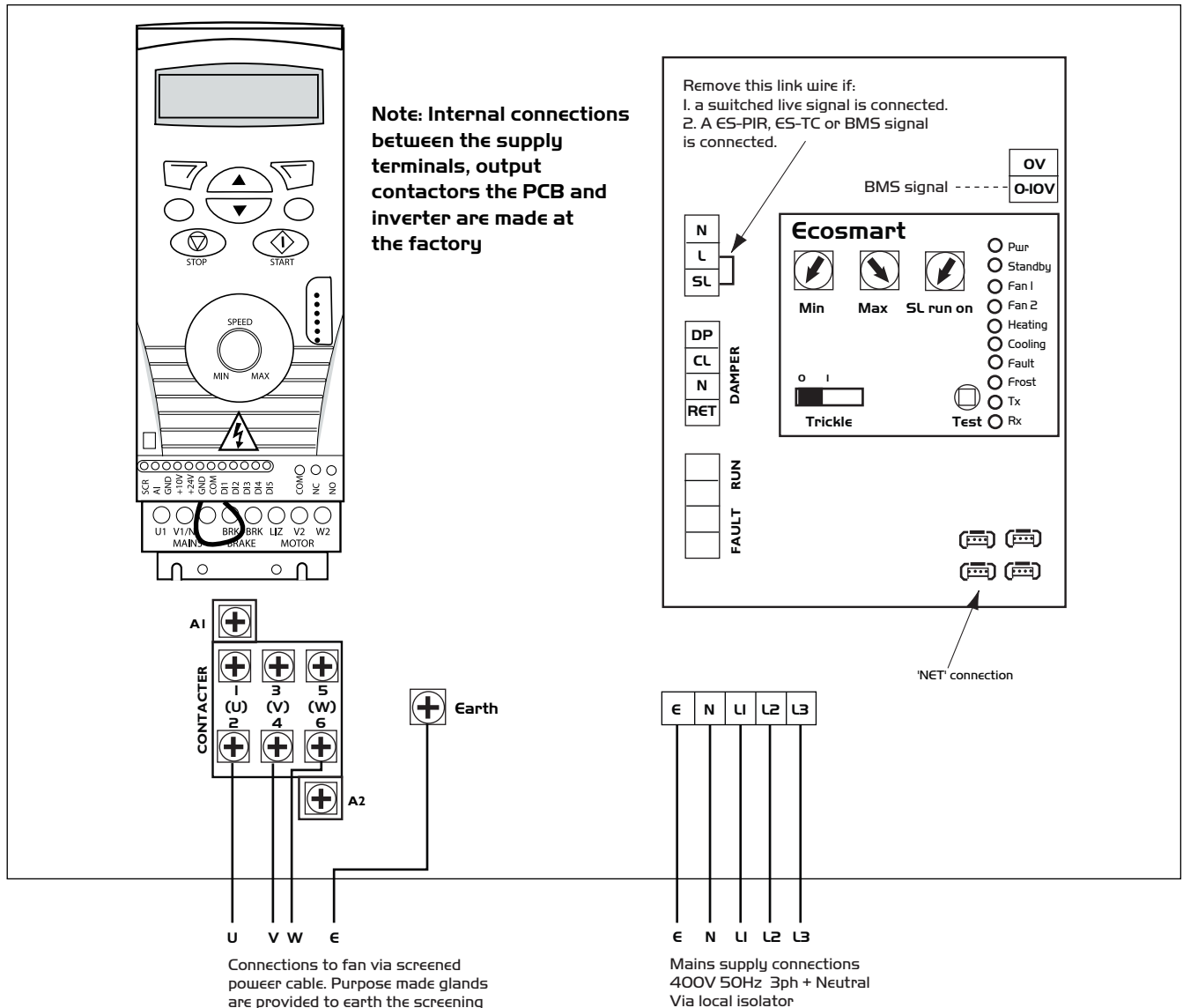

IMPORTANT

The screening of the power cable must be continuous. Bridge any breaks (e.g. at local isolators) using braided earthing cable. Ensure the screening is earthed at both ends.

IMPORTANT

To minimise the possibility of Electro Magnetic interference:

- Always install screened cable between the control and the fan, maximum length 30 metres. Please consult Nuaira if a longer cable run is needed.
- This product must be earthed and always 'earth' the screened cable at both ends.

Ensure that ALL earth connections are the same potential. Cable glands are provided.

- Always keep mains supply cables and motor supply cables separate and DO NOT install any data cable or low voltage cable in the same containment as mains carrying cables.

3.2 Control Connections

a) Mains connections

Mains cables should be suitably sized and terminated at terminals shown on the appropriate diagram.

b) Control Connections

Figure 6. 'Net' connection for Ecosmart devices.

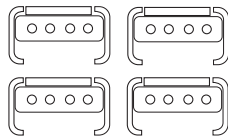

Net - the 4 IDC plug-in connectors are provided for the connection of compatible sensors, manual controls and for linking the fans together under a common control. If more than 4 connections are required, the junction box (product code ES-JB) should be used (see data cable installation).

c) Switched Live (SL) terminal at the PCB

Figure 7.

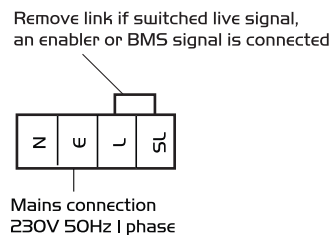

A signal of 100-230V a.c. will activate the fan from either its off state or trickle state (see setting to work-trickle switch). When the SL is disconnected the fan will over-run for 1 - 60 minutes. (see figure 11).

Do not take this signal from an isolating transformer.

d) Damper connections

Figure 8a. Drive open/ Spring close.

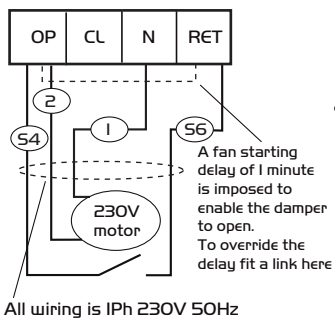
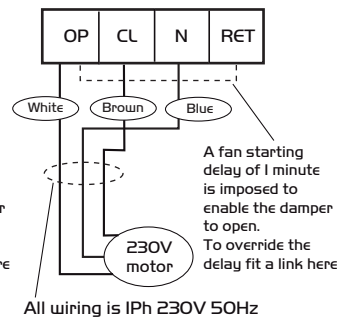

Figure 8b. Drive open/ Drive close.



- OP** - 230V 50Hz IA max supply to open the damper.
 - CL** - 230V 50Hz IA max supply to close the damper.
 - N** - Neutral supply to damper.
 - RET** - 230V ac return signal from the damper limit switch indicates the damper has reached its operating position. If the return signal is not present, the fan will wait for 1 minute before starting.
- Note: If a damper is not fitted, connect a link wire from OP to RET. This will cancel the delay.

e) Volt Free Relay Contacts

Figure 9.

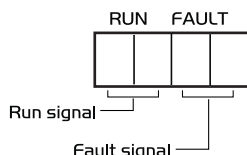

Note that the volt free contacts are not fused. If these are used to power any external equipment, the installer must

provide adequate fusing or other protections. These contacts are rated at 5A resistive, 0.5A inductive. **Run connections** - These contacts are closed when the fan is running.

Fault connections - No fault = the contacts are closed. **Fault** = the contacts are opened.

f) Data cable installation

A 4-core SELV data cable is used to connect devices. Do not run data cable in the same conduit as the mains cables and ensure there is a 50mm separation between the data cable and other cables. The maximum cable run between any two devices is 300m when it is installed in accordance with the instructions.

Please note that the total data cable length used in any system must be less than 1000m. Keep the number of cable joints to a minimum to ensure the best data transmission efficiency between devices.

g) Maximum number of devices

The maximum number of devices (including fans) that can be connected together via the cable is 32, irrespective of their functions.

h) Other low voltage cables e.g. BMS signal

Follow the basic principle (as f). Keep the cable run as short as possible, less than 50 metres. If the cable is longer than 12m, we recommend using screened cable with the screening grounded at one end only (preferably at the inverter end).

j) BMS input signals

The BMS connection is made with a plug-in connector via the socket (See figure 10). To ensure the connection is made only by suitably qualified and authorised personnel the plug is not supplied.

Figure 10.

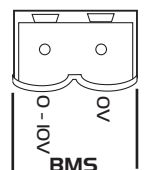

It is available from R S Components, Part No. 403-875 or Farnell, Part No. 963-021.

Reversal of the BMS connection will damage the control.

The system's response to a 0-10V dc BMS signal is given in the table below.

Note the BMS signal will override any sensors and user control connected in the system. The voltage tolerance is +/- 125mV and is measured at the fans terminal.

	Ventilation mode	Cooling mode*	Heating mode*
Local control	0.00	-	-
OFF / trickle	0.25	-	-
Speed 1	0.50	0.75	1.00
Speed 2	1.50	1.75	2.00
Speed 3	2.50	2.75	3.00
Speed 4	3.50	3.75	4.00
Speed 5	4.50	4.75	5.00
Speed 6	5.50	5.75	6.00
Speed 7	6.50	6.75	7.00
Speed 8	7.50	7.75	8.00
Speed 9	8.50	8.75	9.00
Speed 10	9.50	9.75	10.00

* Only available on relevant unit.

4.0 Setting to Work

IMPORTANT

Isolation - Before commencing work make sure that the unit, switched live and Nuair control are electrically isolated from the mains supply.

Warning - Inverter Speed Control

An Inverter is used to provide speed control. When the fan is isolated, allow 5 minutes for the capacitors in the inverter to discharge before commencing any work on the unit.

a) Electrical

Using the Test button

The test button allows the blower within the unit to be checked for its operation. If the fan is running already, press the button once to stop the fan, press again to switch on the fan.

Note that the fan will return to normal operation after 30 seconds.

Figure II.

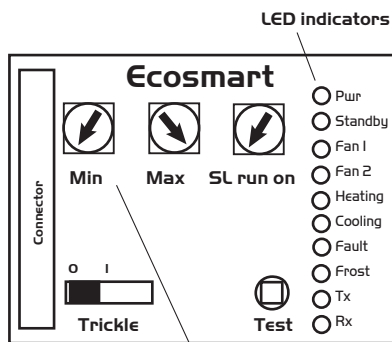

- MIN = Minimum speed adjustment
- MAX = Maximum speed adjustment
- SL = Switched Live Run-On Timer adjustment
- TRICKLE = Selects trickle running: 0 = off, 1 = selected
- TEST = Test button

b) LED Indication

- PWR GREEN: Power on & OK,
- Standby LED on when fan is not running.
- Fan 1 GREEN: Fan 1 is running, RED: Fan 1 faulty.
- Fan 2 GREEN: Fan 2 is running, RED: Fan 2 faulty.
- Heating* GREEN: Heating selected RED:
- Cooling* Not applicable. See note.
- Fault LED on when a fault is present on unit.
- Frost* Not applicable. See note.
- Tx LED on when the controller is transmitting data.
- Rx LED on when the controller is receiving data.

*** Note that the control panel is common to all the Ecosmart products and will have indicators for functions that are not available in this particular fan. However these indicators will not be illuminated.**

c) Settings

Setting the maximum air flow

- i) Ensure the power supply is switched off and that a link wire is connected from the supply L to the SL terminal. Unplug all items connected to the 'Net' connectors.
- ii) Switch on the power supply.
- iii) Wait for the fan to reach steady condition.

Measure the airflow using standard commissioning instruments at a suitable point in the ductwork. If adjustment is required, rotate the pot marked 'MAX' to obtain the desired airflow. Remove the link wire if not required - see "wiring (c)".

Setting the minimum/trickle airflow rate (nominal 20%)

- i) Repeat the same procedure as for maximum airflow above but without the link wire between supply L and SL terminal. Ensure the trickle switch is in the 'ON' position. Adjustment must be made on the pot marked 'Min'.
- ii) Note that the minimum setting (nominally 20%) must be below the maximum setting, otherwise minimum setting will be automatically set to be the same as the maximum.
- iii) The minimum speed set is the trickle speed at which the fan operates.

Note: The working speed range of the user control and sensors is between the minimum and maximum set points.

IMPORTANT

Isolation - Before removing panels make sure that the unit is electrically isolated from the mains supply.

5.0 Maintenance

Only appropriately qualified personnel, familiar not only with the electrical aspect of the work but with the plant, area or application served by the unit, should carry out routine and preventative maintenance on this product. Ensure all mechanical and electrical connections and fixings are secure and that inlet and outlet duct work is free of any obstruction or debris. Briefly switch the fan on/off to ascertain correct direction of rotation, compare the rotational label applied to the fan case and correct if necessary.

5.1 Maintenance Intervals

Maintenance should be carried out on a regular basis, we recommend three months from commissioning and at least annually thereafter as determined by the operating conditions and levels of airborne contamination to which the unit is exposed.

5.2 Maintenance check list

Item	Tick
Check that bird guards/safety grilles are secure and free of obstruction.	
Inspect all bolts, fixings and electrical terminals for security.	
Check motor for undue wear, signs of overheating and apply winding insulation and continuity tests.	
Remove all dust and dirt from impellers, be especially careful not to disturb balance weights.	
Generally clean.	
Check resilient mounts and replace any that show signs of wear or deterioration.	

5.3 Lubrication

Motors are fitted with sealed for life bearings and do not require any lubrication.

5.4 Impellers

Impellers are dynamically balanced during manufacture, no special treatment is required during maintenance, other to clean and remove all dust and dirt residue taking care not to disturb the balance weights. Remove stubborn dirt with warm soapy water – do not use caustic fluids.

If ATEX compliant, observe the advice of guidance note document 671216.

The maintenance programme must conform to 'good custom and practice' and to the published recommendations of associations such as the HVCA, CIBSE etc. The HVCA's publication 'Standard Maintenance Specification for Mechanical Services in Buildings' Vol 2 Ventilating and Air Conditioning is a recommended reference.

6.0 Replacement of Parts

Should any component need replacing Nuaire keep extensive stocks for quick delivery. Ensure that the unit is electrically isolated, before carrying out any work.

When ordering spare parts, please quote the serial number of the unit and the ARC number of the purchase if possible.

(This information will be available on the fan label).

7.0 Warranty

Axus AX units have a 3 year warranty.

Units with Ecosmart control have a 5 year warranty.

The warranty starts from the day of delivery and includes parts and labour for the first year.

The remaining period covers replacement parts only.

This warranty is conditional on planned maintenance being undertaken.

8.0 Service Enquiries

Nuaire can assist you in all aspects of service. Our Technical Support department will be happy to provide any assistance required.



Telephone 029 2085 8400

DECLARATION OF INCORPORATION AND INFORMATION FOR SAFE INSTALLATION, OPERATION AND MAINTENANCE

We declare that the machinery named below is intended to be assembled with other components to constitute a system of machinery. The machinery shall not be put into service until the system has been declared to be in conformity with the provisions of the EC Machinery Directive.

Designation of machinery: AXUS AXIAL FAN
Machinery Types: AX
Relevant EC Council Directives: 98/37/EC as amended by 98/79/EC (Machinery Directive)
Applied Harmonised Standards: BS EN ISO 12100-1, BS EN ISO 12100-2, EN294, EN60204-1, BS EN ISO 9001
Applied National Standards: BS848 Parts One, Two and Five

Signature of manufacture representatives:

Name:	Position:	Date:
1) C. Biggs 	Technical Director	29. 09. 13
2) A. Jones 	Manufacturing Director	29. 09. 13

INFORMATION FOR SAFE INSTALLATION, OPERATION AND MAINTENANCE OF NUAIRE VENTILATION EQUIPMENT

To comply with EC Council Directives 98/37/EC Machinery Directive and 2004/108/EC (EMC).

To be read in conjunction with the relevant Product Documentation (see 2.1)

1.0 GENERAL

1.1 The equipment referred to in this Declaration of Incorporation is supplied by Nuairé to be assembled into a ventilation system which may or may not include additional components.
 The entire system must be considered for safety purposes and it is the responsibility of the installer to ensure that all of the equipment is installed in compliance with the manufacturers recommendations and with due regard to current legislation and codes of practice.

2.0 INFORMATION SUPPLIED WITH THE EQUIPMENT

2.1 Each item of equipment is supplied with a set of documentation which provides the information required for the safe installation and maintenance of the equipment. This may be in the form of a Data sheet and/or Installation and Maintenance instruction.
 2.2 Each unit has a rating plate attached to its outer casing. The rating plate provides essential data relating to the equipment such as serial number, unit code and electrical data. Any further data that may be required will be found in the documentation. If any item is unclear or more information is required, contact Nuairé.
 2.3 Where warning labels or notices are attached to the unit the instructions given must be adhered to.

3.0 TRANSPORTATION, HANDLING AND STORAGE

3.1 Care must be taken at all times to prevent damage to the equipment. Note that shock to the unit may result in the balance of the impeller being affected.
 3.2 When handling the equipment, care should be taken with corners and edges and that the weight distribution within the unit is considered. Lifting gear such as slings or ropes must be arranged so as not to bear on the casing.
 3.3 Equipment stored on site prior to installation should be protected from the weather and steps taken to prevent ingress of contaminants.

4.0 OPERATIONAL LIMITS

4.1 It is important that the specified operational limits for the equipment are adhered to e.g. operational air temperature, air borne contaminants and unit orientation.
 4.2 Where installation accessories are supplied with the specified equipment eg. wall mounting brackets. They are to be used to support the equipment only. Other system components must have separate provision for support.
 4.3 Flanges and connection spigots are provided for the purpose of joining to duct work systems. They must not be used to support the ductwork.

5.0 INSTALLATION REQUIREMENTS

In addition to the particular requirements given for the individual product, the following general requirements should be noted.

5.1 Where access to any part of equipment which moves, or can become electrically live are not prevented by the equipment panels or by fixed installation detail (eg ducting), then guarding to the appropriate standard must be fitted.
 5.2 The electrical installation of the equipment must comply with the requirements of the relevant local electrical safety regulations.
 5.3 For EMC all control and sensor cables should not be placed within 50mm or on the same metal cable tray as 230V switched live, lighting or power cables and any cables not intended for use with this product.

6.0 COMMISSIONING REQUIREMENTS

6.1 General pre-commissioning checks relevant to safe operation consist of the following:
 Ensure that no foreign bodies are present within the fan or casing.
 Check electrical safety. e.g. Insulation and earthing.
 Check guarding of system.
 Check operation of Isolators/Controls.
 Check fastenings for security.
 6.2 Other commissioning requirements are given in the relevant product documentation.

7.0 OPERATIONAL REQUIREMENTS

7.1 Equipment access panels must be in place at all times during operation of the unit, and must be secured with the original fastenings.
 7.2 If failure of the equipment occurs or is suspected then it should be taken out of service until a competent person can effect repair or examination. (Note that certain ranges of equipment are designed to detect and compensate for fan failure).

8.0 MAINTENANCE REQUIREMENTS

8.1 Specific maintenance requirements are given in the relevant product documentation.
 8.2 It is important that the correct tools are used for the various tasks required.
 8.3 If the access panels are to be removed for any reason the electrical supply to the unit must be isolated.
 8.4 A minimum period of two minutes should be allowed after electrical disconnection before access panels are removed. This will allow the impeller to come to rest.
NB: Care should still be taken however since airflow generated at some other point in the system can cause the impeller to "windmill" even when power is not present.
 8.5 Care should be taken when removing and storing access panels in windy conditions.

Technical or commercial considerations may, from time to time, make it necessary to alter the design, performance and dimensions of equipment and the right is reserved to make such changes without prior notice.