



MRXBOX95B-LPI

Mechanical Ventilation Unit with Heat Recovery & Summer Bypass for Ceiling Void Mounting

Installation and Maintenance

CE The EMC Directive 2004/108/EC
The Low Voltage Directive 2006/95/EC

1.0 Introduction

IMPORTANT

The unit must remain switched on at all times to maintain ventilation within the dwelling. Turning the unit off will cause long term damage to the unit and building fabric.

This appliance is not intended for use by persons (including children) with reduced physical, sensory or mental capabilities, or lack of experience and knowledge, unless they have been given supervision or instruction concerning the use of the appliance by a person for their safety. Children should be supervised so that they do not play with the appliance.

MRXBOX95B-LPI ceiling void mounted unit is designed to provide mechanical supply and extract ventilation with heat recovery and incorporates summer bypass.

The unit is fitted with two independent fans. Each fan has full speed control for background and boost ventilation rates. To recover heat from the extract air the heat exchanger block is utilised. The heat exchanger can recover up to 80% of the normally wasted heat.

The bypass damper opens automatically via a wax actuator when the outside air reaches 20°C, when the outer air temperature returns below this level the unit returns to its original state. Outside air supplied through the bypass is still being filtered, so the air quality is optimal, irrespective of the bypass setting (open or closed).

The unit is fitted with a frost protection mode, in the event of the fresh air temperature dropping below -5 Deg C the supply fan will switch off. The unit will then automatically switch back on when the temperature raises back above -5 Deg C.

Figure 1. Airflow through unit.

Spigots 1 to 4

1. Intake air (Fresh Air from outside).
2. Supply Air (Supply in to house).
3. Extract Air (Warm air from house).
4. Exhaust Air (Waste air to outside).

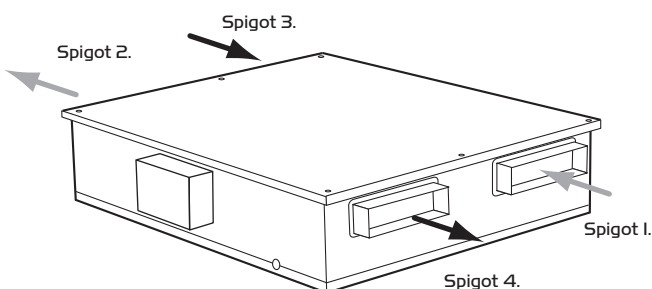

Note: The unit must be installed in an upright position as shown for the condensate drain and for compliance with safety regulations relating to IP protection for water drip ingress.

2.0 Installation

Installation must be carried out by competent personnel in accordance with the appropriate authority and conforming to all statutory governing regulations. All mains wiring must be in accordance with the current I.E.E. Regulations, or the appropriate standards. Ensure that the mains supply (Voltage, Frequency and Phase) complies with the rating label.

Please note a clear working space is required around the installed unit to allow the cover to be removed and provide sufficient access for maintenance such as filter change.

The fan must be installed indoors, in a suitable ceiling void away from direct sources of frost, heat, water spray or moisture generation. For a vibration-free result the unit must be mounted to a solid surface in the void.

The unit is designed for ceiling mounting only (Horizontal surface).

1. The unit is supplied with a steel mounting bracket.
2. Position & secure the steel bracket to the ceiling using appropriate fixings (supplied by others), ensuring that the two outer fixing holes on the unit are accessible.

Note: The mounting bracket should be on the same side as the condensate take off.

3. The unit can now be offered into position & located into the mounting bracket.
4. Using appropriate fixings (supplied by others), fix the unit to the ceiling. It is recommended that the unit is fixed through three holes on the non-bracket side and the two outer holes on the bracket side.

Figure 2. Installing the unit using appropriate fixing bolts.

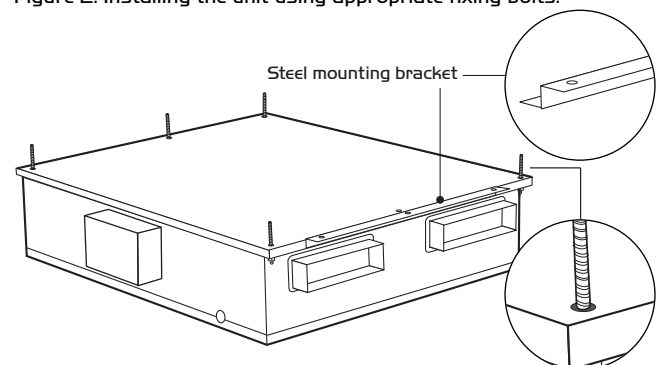
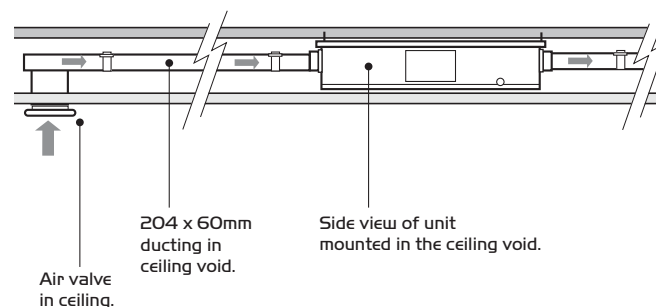

Figure 3. Typical side view example of a unit mounted in a ceiling void using 204 x 60mm rectangular ducting and air valves.



2.1 Condensate Drain installation

1. Unit comes complete with external drain pipe (21.5mm waste pipe). Use conventional plumbing connections to link up with U-trap or alternative drain method (Solvent cement connections or compression fit connections are recommended). The condensate must be discharged under a water level in a U-trap drainpipe or an alternative drain method which acts as an airlock.
2. This condensate discharge connection is suitable for 21.5mm dia. overflow pipe. Solvent cement should be used to make the joint.
3. If using a U-trap please ensure the U-trap has been filled to a suitable level of water to avoid any air locks.
4. If the condensation pipe is fitted in an unheated space the pipe should be insulated to prevent freezing.

Nuairé recommend MVHR-DRAIN be used as the primary condensate take-off. (see figures 4a and 4b).

Figure 4a. MVHR-DRAIN condensate drain, running to SVP.

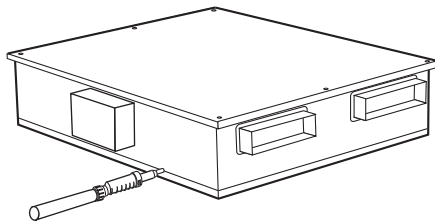
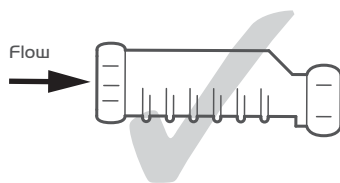
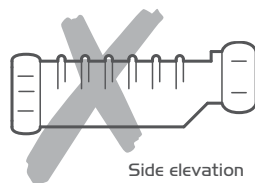

Figure 4b. MVHR-DRAIN correct installation.

RIGHT



WRONG



Side elevation

When installed horizontally the ribs must be at the bottom to ensure correct operation.

Fixing

Offer up the MVHR-DRAIN inlet to the threaded tail of the appliance waste outlet or MVHR-DRAIN knuckle or running adaptor, and tighten the threaded cap sufficiently hand-tight to provide a water-tight seal (check that the cap screws on square and does not 'cross-thread'). When the screwed cap is tight, the MVHR-DRAIN body is secure.

1. Cut the pipe to length, allowing for the full compression socket depth (using an appropriate pipe cutter, such as a Hepworth ratchet pipe cutter).
2. Remove any 'swarf' from the end of the plastic pipe. Ream the copper pipe end to remove any 'burr', and file if necessary to remove any external sharp edges. Mark the socket depth on the pipe, and check that the pipe section to be jointed is free of any surface damage which may affect the joint seal.
3. Unscrew the cap from the MVHR-DRAIN outlet, and slide the cap and rubber seal onto the pipe.
4. Insert the pipe end fully into the socket.
5. Slide the rubber seal and screwed cap up against the face of the socket, and tighten the cap sufficiently hand-tight (check that the cap is square to the body and does not 'cross-thread'). Hand tight should be adequate to form a proper seal.

2.2 Extract/input areas

The unit is designed to extract air from all wet rooms e.g. bathroom, kitchen, en-suite, utility room (with sink). WC's do not need to be ventilated if openable windows are fitted. Supply air should be to all habitable rooms e.g. bedrooms and lounge. Extract / input grilles should be adjustable valve types (not supplied). External grilles to have a minimum free area of 12,250 sq mm.

2.3 Ducting

Before commencing ducting installation reference should be made to building regulations document "Domestic ventilation compliance guide". This document supports ADF2010 and details installation, testing and commissioning of all ventilation systems.

It is recommended that rigid ducting must be used it all times. Flexible ducting has a very high resistance and it is impossible to calculate how much resistance will be on a system if used.

If used the flexible ducting must be kept to a minimum and should always be pulled taut. A maximum of 300mm should be used on each leg.

To prevent condensation on the outside of the outside air inlet duct and the air outlet duct from the MRXBOX95B-LPI, these ducts should be insulated.

Ducting must be installed in such a way that resistance to airflow is minimised. Bends should be kept to a minimum.

A minimum distance of 200mm between the appliance and any bends in ductwork is recommended.

204 x 60mm rectangular ducting should be used. (Refer to dwelling ducting design drawing, figure 6 on page 4 for further information).

Ducting joints must be sealed with silicone type sealant and needs to be taped. Ducting shall be adequately and reliably fixed to the appliance.

2.4 Ventilation flow rates

Table 1.

ADF2006 / 2010 – Extract ventilation rates

Room	Min high rate	Min low rate
Kitchen	13 l/s	Total extract rate should be at least the whole dwelling ventilation rate given in table 2.
Utility room	8 l/s	
Bathroom	8 l/s	
Sanitary accommodation	6 l/s	

Table 2.

Whole dwelling ventilation rates

	Number of bedrooms in dwelling				
	1	2	3	4	5
Whole dwelling ventilation rate l/s 1, 2	13	17	21	25	29

Notes:

1, In addition, the minimum ventilation rate should be not less than 0.3 l/s per m² of internal floor area.

(This includes all floors, e.g. for a two-story building add the ground and first floor areas).

2, This is based on two occupants in the main bedroom and a single occupant in all other bedrooms. This should be used as the default value. If a greater level of occupancy is expected add 4 l/s per occupant.

2.5 Air permeability and infiltration

Is the uncontrolled exchange of air between inside and outside through cracks, porosity and other unintentional openings in the building. ADF2006 gives an allowance for this in both multi and single storey buildings, however ADF2010 has an allowance for multi storey only. Additionally ADF2010 only applies this allowance for dwellings leakier than $5 \text{ m}^3/(\text{h.m}^2)$ at 50Pa. (See below).

2.6 ADF 2006 Ventilation calculations Continuous supply and extract

Step 1: Determine the whole building ventilation rate from **Table 2**. Allow for infiltration by subtracting from this value:

- for multi-storey dwellings: $0.04 \times$ gross internal volume of the dwelling heated space (m^3);
- for single-storey dwellings: $0.06 \times$ gross internal volume of the dwelling heated space (m^3).

Step 2: Calculate the whole dwelling air extract rate at maximum operation by summing the individual room rates for 'minimum high rate' from **Table 1**.

(For sanitary accommodation only, as an alternative, the purge ventilation provisions given in ADF 2006 can be used where security is not an issue. In this case 'minimum high extract rate' for the sanitary accommodation should be omitted from the step 2 calculation).

Step 3: The required airflow rates are as follows:

- the maximum extract rate (e.g. boost) should be at least the greater of step 1 and step 2. Note that the maximum individual room extract rate should be at least those given in **table 1**. for minimum high rate.
- the minimum air supply rate should be at least the whole building ventilation rate found in step 1.

IMPORTANT

Any air intake terminal **MUST** be installed in accordance with the appropriate regulation.

As a guide, the BS5440 series of British Standards deals with this issue and currently states that an air intake must be at a minimum distance of 300mm from a gas boiler balanced flue.

Installers are advised to be aware of the requirements of this standard when installing 'through the wall' supply air ducting.

Similarly, supply and extract air grilles should be at least 300mm apart.

2.7 ADF 2010 Ventilation calculations

Design of MVHR systems

The MVHR system has been sized for the winter period. Additional ventilation may be required during the warmer months and it has been assumed that the provisions for purge ventilation (e.g. openable windows) could be used.

Step 1: For any design air permeability, determine the whole dwelling ventilation supply rate from **Table 2**.

As an alternative where the design air permeability is intended to be leakier than ($>$) $5 \text{ m}^3/(\text{h.m}^2)$ 50 Pa, allow for infiltration for all dwelling types by subtracting from the whole dwelling ventilation supply rate from **Table 2**; $0.04 \times$ gross internal volume of the dwelling heated space (m^3).

Step 2: Calculate the whole dwelling extract ventilation rate by summing the individual room rates for 'minimum high rate' from **Table 1**.

(For sanitary accommodation only, as an alternative, the purge ventilation provisions given in ADF 2010 can be used where security is not an issue. In this case 'minimum high extract rate' for the sanitary accommodation should be omitted from the step 2 calculation).

Step 3: The required airflow rates are as follows:

- the maximum whole dwelling extract ventilation rate (e.g. boost) should be at least the greater of step 1 and step 2.

Note that the maximum individual room extract rate should be at least those given in **table 1**. for minimum high rate.

- the minimum air supply rate should be at least the whole building ventilation rate found in step 1.

For Scotland refer to **BRE Digest 398**.

Pre Commissioning MRXBOX95 MVHR Units

MRXBOX95 units are designed to ventilate the whole dwelling and must not be used during site construction or the clean-up period. Cement and plaster dust can be abrasive and can affect fan performance and reliability. Please ensure that the filters are checked prior to commissioning to ensure there is no build-up of dust or debris.

While the property is drying out, very high moisture levels are likely to occur. Therefore it is advisable that if the installation and building works are complete the unit is left running. If the building works are not complete please close the air valves or cover up the air valves to prevent condensation forming in the ductwork and the MRXBOX95 unit due to natural migration of warm air.

3.0 Dimensions (mm)

Figure 5. Also shows the working space required.

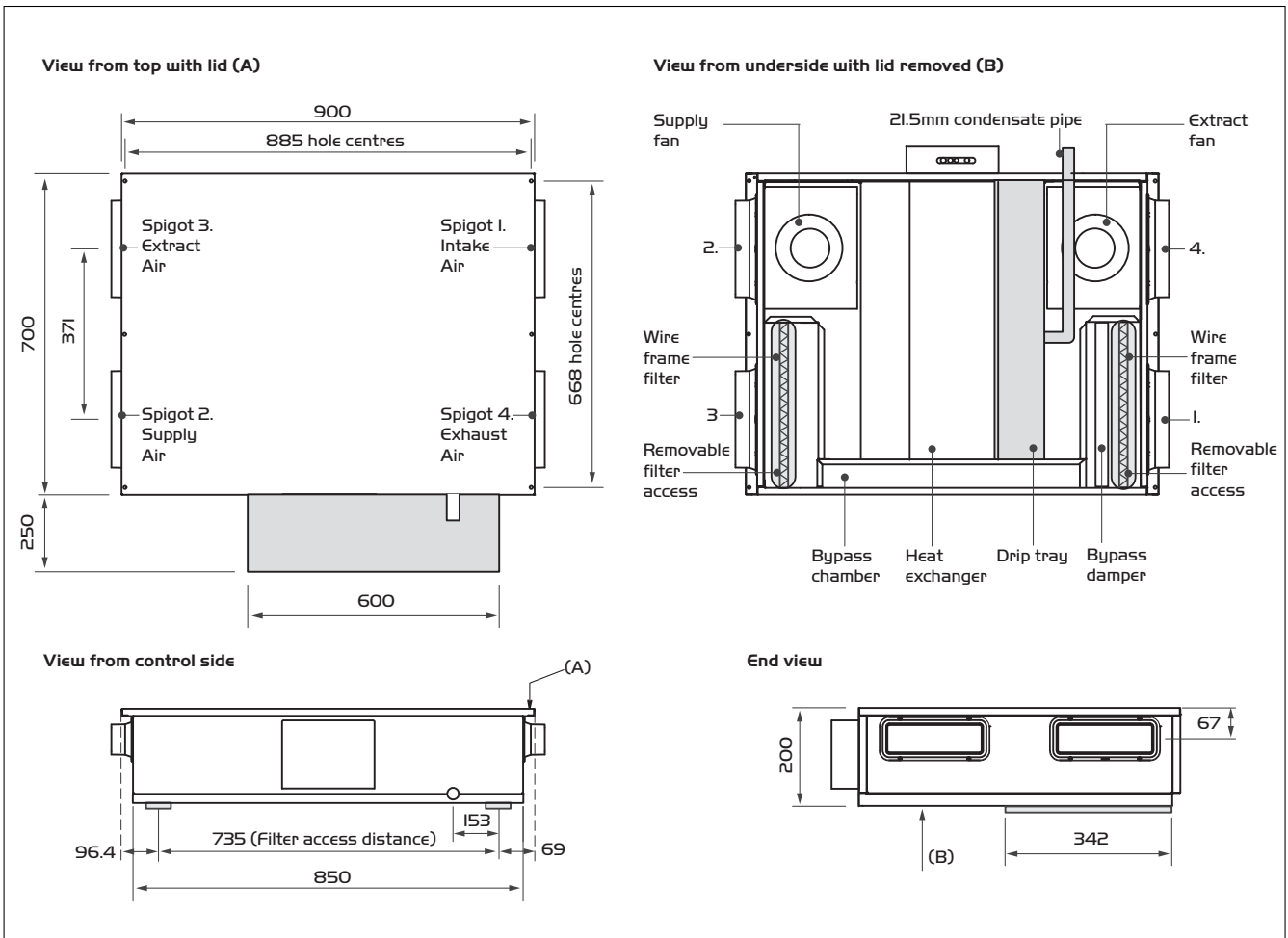

4.0 Ducting arrangements

Figure 6. Typical ducted arrangement for a void mounted unit using using rectangular 204 x 60mm ducting and ceiling air valves.

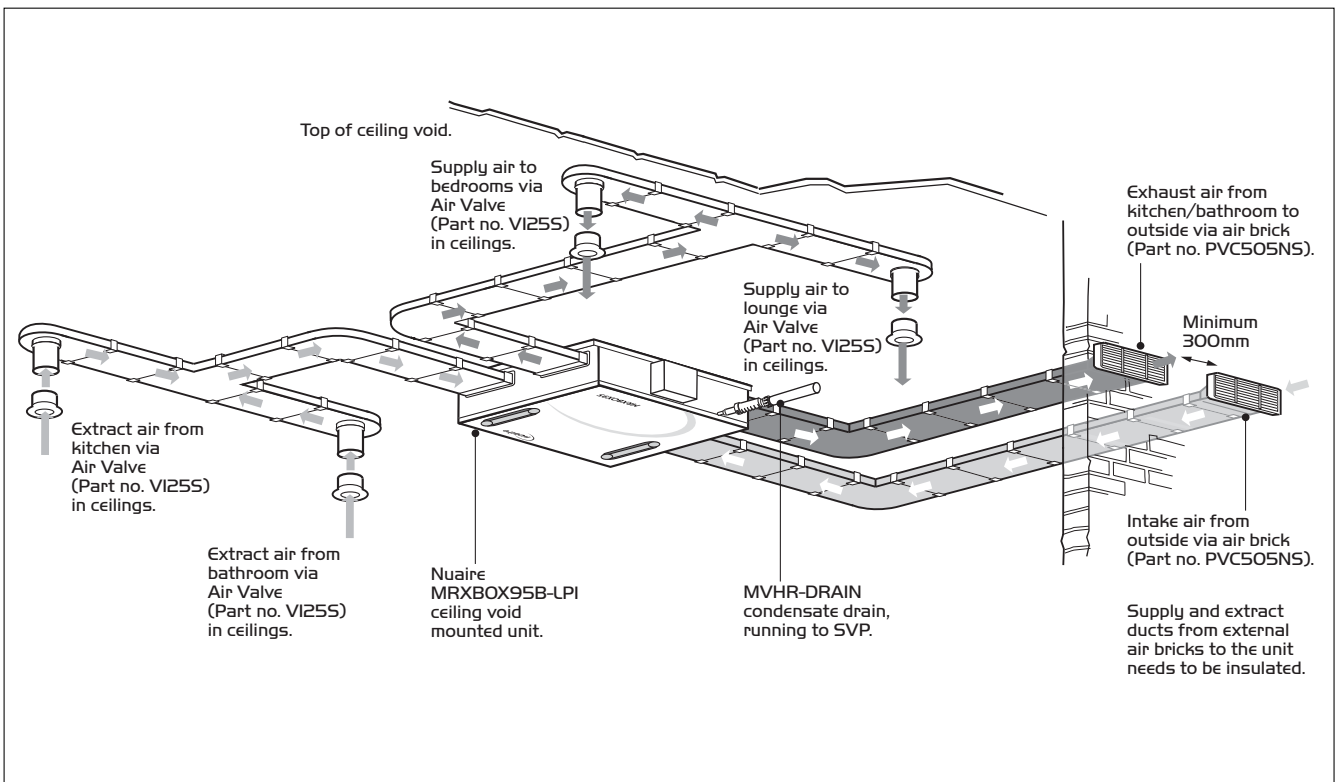

5.0 Electrical Connection

IMPORTANT

For good EMC engineering practice, any sensor cables or switched live cables should not be placed within 50mm of other cables or on the same metal cable tray as other cables.

Please note: the electrical connection of the unit must be carried out by a qualified electrician.

The unit is supplied with a flexible cord for connection to the mains supply.

Electrical details:-

Voltage: 240V lph 50Hz

Consumption: LPI - 1.3 Amp

Fuse rating: 3 Amp

NOTE This unit must be earthed.

The three core cable from the mains power supply should be connected to a fixed wiring installation, via a fused isolator, in accordance with current IEE wiring regulations.

Figure 7.

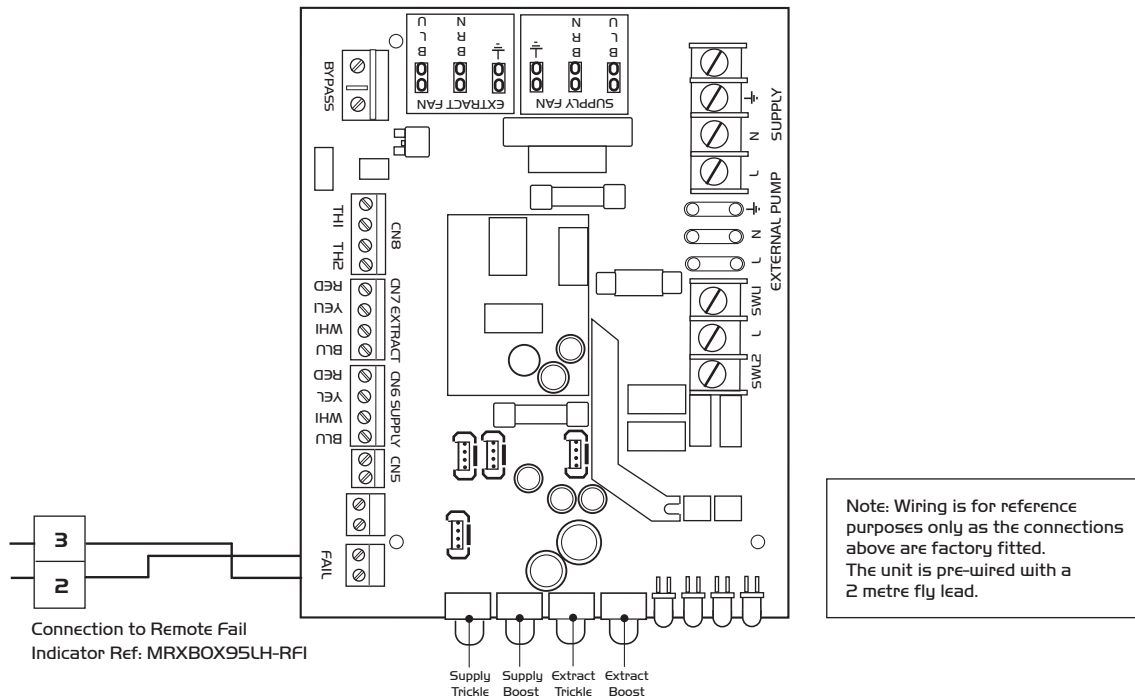

Unit serving kitchen and bathroom

Figure 8.

Disconnection from the supply mains must be incorporated within the fixed wiring in accordance with the wiring regulations and shall have a minimum contact separation of 3mm.

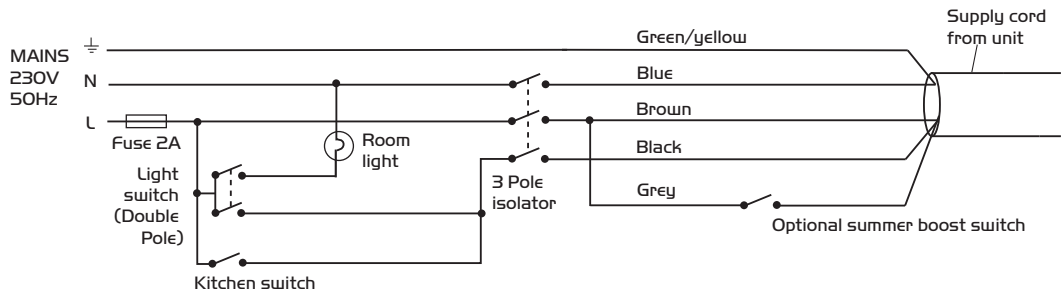

Unit serving kitchen and two bathrooms

Figure 9.

Disconnection from the supply mains must be incorporated within the fixed wiring in accordance with the wiring regulations and shall have a minimum contact separation of 3mm.

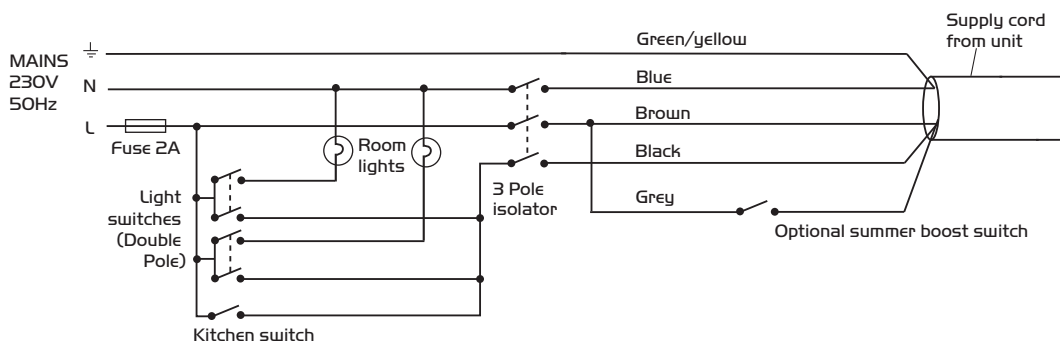

6.0 Commissioning

IMPORTANT

The filters fitted inside the unit are protected with a plastic film. Prior to commissioning remove the covers (fig 13), take off the film and replace.

1. For the required air flow rates please refer to the design specification for the property, follow 2.4, or refer to building regulations ADF 2006/2010.
2. The unit is supplied with independent control for both normal and boost airflows. (see fig. 10).
3. Correct commissioning is essential to ensure the ventilation air flowrates are met. It also ensures the unit is not over ventilating and causing excessive power consumption.
4. Commissioning should be carried out in accordance with building regulations document "Domestic ventilation compliance guide". A calibrated moving vane anemometer and hood will be required to carry out commissioning.
5. Adjustment valves should be locked in place to prevent further adjustment.
6. Once commissioned the home owner / tenant should be informed that the unit should not be adjusted as it will have a detrimental effect on the indoor air quality and could result in condensation and mould growth. The label covering the control has an adhesive panel which should be removed post commissioning to prevent tampering.

Figure 10. PCB inside enclosure.

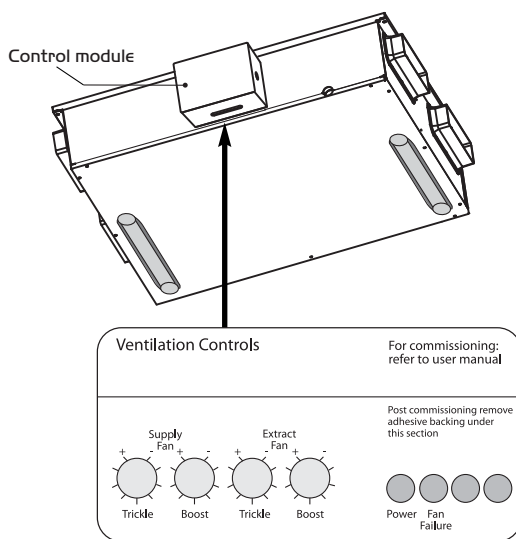

7.0 Maintenance/Cleaning

IMPORTANT

Isolation - Before commencing work make sure that the unit, switched live and Nuair control are electrically isolated from the mains supply and switched live supply.

We recommend that the two G3 filters are inspected after 6 months, and replaced every 12 to 18 months.

The filters can be removed from the unit by removing the two filter covers on the bottom panel of the unit. Take hold of the two circular tabs either end of the filter covers and pull to remove. (see fig. 11).

The filter can now be extracted by pulling the removal loop on the edge of the filter. Once the filters have been inspected return or replace them as necessary.

Inspect the heat exchanger every 5 years. Generally check for damage and security of components. Refit cover.

Figure 11. Remove the two filter covers on the underside panel of the unit, and the filters can be pulled out of the unit using the tab on the lower edge of the filter.

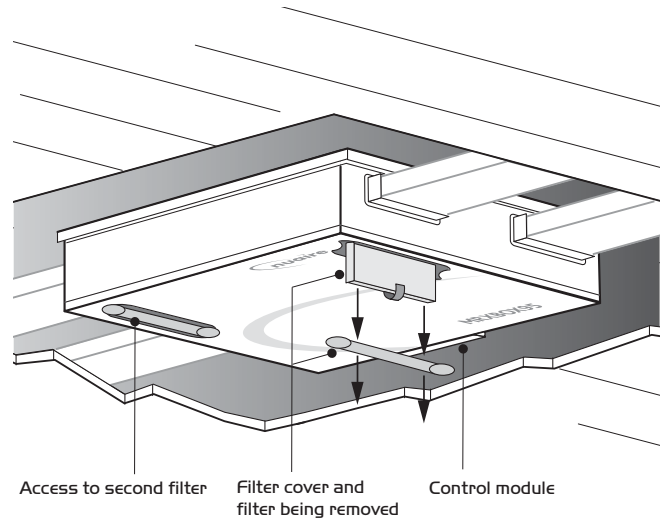

8.0 Replacement of Parts

Should any component need replacing Nuair keep extensive stocks for quick delivery. Ensure that the unit is electrically isolated, before carrying out any work.

Note: The supply cable must be replaced by an electrically competent person.

When ordering spare parts, please quote the serial number of the unit and the ARC number of the purchase if possible. (This information will be available on the fan label).

9.0 Warranty

The 5 year warranty starts from the day of delivery and includes parts and labour for the first year and parts only for the remaining 4 years. This warranty is conditional on planned maintenance being undertaken.

10.0 Service Enquiries

Nuair can assist you in all aspects of service. Our service department will be happy to provide any assistance required, initially by telephone and if necessary arrange for an engineer to call.

Technical Support
029 2085 8400

Technical or commercial considerations may, from time to time, make it necessary to alter the design, performance and dimensions of equipment and the right is reserved to make such changes without prior notice.



DECLARATION OF INCORPORATION AND INFORMATION FOR SAFE INSTALLATION, OPERATION AND MAINTENANCE

We declare that the machinery named below is intended to be assembled with other components to constitute a system of machinery. All parts except for moving parts requiring the correct installation of safety guards comply with the essential requirements of the Machinery Directive. The machinery shall not be put into service until the system has been declared to be in conformity with the provisions of the EC Machinery Directive.

Designation of machinery: MRXBOX95B-LPI
Machinery Types: Mechanical Ventilation with Heat Recovery & Summer Bypass
Relevant EC Council Directives: 2006/42/EC (Machinery Directive)
Applied Harmonised Standards: BS EN ISO 12100-1, BS EN ISO 12100-2, EN60204-1, BS EN ISO 9001, BS EN ISO 13857
Applied National Standards: BS848 Parts 1, 2.2 and 5

Note: All standards used were current and valid at the date of signature.

Signature of manufacture representatives:

Name:	Position:	Date:
1) C. Biggs 	Technical Director	12. 05. 12
2) A. Jones 	Manufacturing Director	12. 05. 12

CE DECLARATION OF CONFORMITY

We declare that the machine named below conforms to the requirements of EC Council Directives relating to Electromagnetic Compatibility and Safety of Electrical Equipment.

Designation of machinery: MRXBOX95B-LPI
I & M Serial No.: 671582
Machinery Types: Mechanical Ventilation with Heat Recovery & Summer Bypass
Relevant EC Council Directives: 2004/108/EC (EMC), 2006/95/EC (Low Voltage Directive)
Applied Harmonised Standards: EN55014-1, EN55014-2, EN61000-3-2, EN61000-3-3, EN60335-2-80
Basis of Self Attestation: Quality Assurance to BS EN ISO 9001 BSI Registered Firm Certificate No. FM 149

Signature of manufacture representatives:

Name:	Position:	Date:
1) C. Biggs 	Technical Director	12. 05. 12
2) A. Jones 	Manufacturing Director	12. 05. 12

Nuaire Ltd,
 Western Industrial Estate,
 Caerphilly CF83 1NA.

Note: All standards used were current and valid at the date of signature.

INFORMATION FOR SAFE INSTALLATION, OPERATION AND MAINTENANCE OF NUAIRE VENTILATION EQUIPMENT

To comply with EC Council Directives 2006/42/EC Machinery Directive and 2004/108/EC (EMC).

To be read in conjunction with the relevant Product Documentation (see 2.I)

1.0 GENERAL

1.1 The equipment referred to in this Declaration of Incorporation is supplied by Nuaire to be assembled into a ventilation system which may or may not include additional components.

The entire system must be considered for safety purposes and it is the responsibility of the installer to ensure that all of the equipment is installed in compliance with the manufacturers recommendations and with due regard to current legislation and codes of practice.

2.0 INFORMATION SUPPLIED WITH THE EQUIPMENT

2.1 Each item of equipment is supplied with a set of documentation which provides the information required for the safe installation and maintenance of the equipment. This may be in the form of a Data sheet and/or Installation and Maintenance instruction.

2.2 Each unit has a rating plate attached to its outer casing. The rating plate provides essential data relating to the equipment such as serial number, unit code and electrical data. Any further data that may be required will be found in the documentation. If any item is unclear or more information is required, contact Nuaire.

2.3 Where warning labels or notices are attached to the unit the instructions given must be adhered to.

3.0 TRANSPORTATION, HANDLING AND STORAGE

3.1 Care must be taken at all times to prevent damage to the equipment. Note that shock to the unit may result in the balance of the impeller being affected.

3.2 When handling the equipment, care should be taken with corners and edges and that the weight distribution within the unit is considered. Lifting gear such as slings or ropes must be arranged so as not to bear on the casing.

3.3 Equipment stored on site prior to installation should be protected from the weather and steps taken to prevent ingress of contaminants.

4.0 OPERATIONAL LIMITS

4.1 It is important that the specified operational limits for the equipment are adhered to e.g. operational air temperature, air borne contaminants and unit orientation.

4.2 Where installation accessories are supplied with the specified equipment e.g. wall mounting brackets. They are to be used to support the equipment only. Other system components must have separate provision for support.

4.3 Flanges and connection spigots are provided for the purpose of joining to duct work systems. They must not be used to support the ductwork.

4.4 In the event of RF interference the fan may change speed. This is normal and will have no adverse effect on the fan. The speed will return to normal once the interference has subsided.

5.0 INSTALLATION REQUIREMENTS

In addition to the particular requirements given for the individual product, the following general requirements should be noted.

5.1 Where access to any part of equipment which moves, or can become electrically live are not prevented by the equipment panels or by fixed installation detail (eg ducting), then guarding to the appropriate standard must be fitted.

5.2 The electrical installation of the equipment must comply with the requirements of the relevant local electrical safety regulations.

5.3 For EMC all control and sensor cables should not be placed within 50mm or on the same metal cable tray as 230V switched live, lighting or power cables and any cables not intended for use with this product.

6.0 COMMISSIONING REQUIREMENTS

6.1 General pre-commissioning checks relevant to safe operation consist of the following:

Ensure that no foreign bodies are present within the fan or casing.

Check electrical safety. e.g. Insulation and earthing.

Check guarding of system.

Check operation of Isolators/Controls.

Check fastenings for security.

6.2 Other commissioning requirements are given in the relevant product documentation.

7.0 OPERATIONAL REQUIREMENTS

7.1 Equipment access panels must be in place at all times during operation of the unit, and must be secured with the original fastenings.

7.2 If failure of the equipment occurs or is suspected then it should be taken out of service until a competent person can effect repair or examination. (Note that certain ranges of equipment are designed to detect and compensate for fan failure).

8.0 MAINTENANCE REQUIREMENTS

8.1 Specific maintenance requirements are given in the relevant product documentation.

8.2 It is important that the correct tools are used for the various tasks required.

8.3 If the access panels are to be removed for any reason the electrical supply to the unit must be isolated.

8.4 A minimum period of two minutes should be allowed after electrical disconnection before access panels are removed. This will allow the impeller to come to rest.

NB: Care should still be taken however since airflow generated at some other point in the system can cause the impeller to "windmill" even when power is not present.

8.5 Care should be taken when removing and storing access panels in windy conditions.

Installation Guide and Checklist

Mechanical Ventilation with Heat Recovery

(Version – 11 February 2011)

The Electric Heating and Ventilation Association have developed this guidance and checklist document in partnership with the Residential Ventilation Association (a HEVAC association), BRE and EST.

NOTE: This guide and checklist has been superseded for dwellings assessed under 'The Building Regulations 2010', specifically SAP 2009 and Approved Documents L and F. Completion of this document is therefore only required for dwellings assessed by SAP 2005.

Customer Details
Customer Name:
Address:
Telephone Number:
Date of Installation:
Name of Lead Contractor:
Design Project Number:

It should be noted that this guidance is not intended to replace product manufacturer installation instructions; it is a generic addition which defines good practice. Installers are advised to complete this form for each installation and keep a copy to provide to Building Control Officers in case requested.

Introduction

This document is to be used in support of the SAP Appendix Q scheme which provides tested performance values for MVHR products.

Note that all checklist items must be answered YES in order for the SAP Appendix Q test figures to be used in 'As built' SAP calculations. If any checklist items are answered NO then SAP default figures must be used. Systems must be designed by a manufacturer designer and sized correctly to qualify for SAP Appendix Q figures.

SECTION 1: INSTALLATION GUIDANCE

1. Ductwork Installation	Decision Yes, No or N/A
<p>Have the ducts been installed with as little air resistance and leakages as possible (flexible ducts should be avoided)?</p> <p>Note: Refer to HVCA DW/143 document 'A Practical Guide to Ductwork Leakage Testing' for detailed guidance on air tightness. Rigid plastic ducting is recommended and flexible duct should only be used in very short lengths and mainly just to connect the ductwork to the units/diffusers or to overcome particular obstructions.</p>	
<p>If flexible ducting has been used, has it been pulled taut to minimise system resistance?</p>	
<p>Has the number of duct bends been minimised to ensure adequate air flow and least resistance? Bends should have a minimum radius at least the same as the diameter of the ducting used?</p> <p>Refer to Figure 1 if using flexible ducting</p>	
<p>Have the fans and ducting placed in unheated voids been insulated to reduce the possibility of condensation forming (see notes below)?</p> <p>Note: Ducts should be insulated with the equivalent of at least 25mm of insulating material with a thermal conductivity of 0.04W/mK. Where a duct rises vertically it may be necessary to fit a condensation trap in order to prevent backflow of any moisture in the product. Insulation should be applied to both warm and cold air ducts. Cold air ducts should be wrapped additionally with a vapour barrier outside the insulation. Ducts with cold air running in warm environments will condense on the outside of the duct.</p>	
<p>Have recommended duct jointing collars and components been used to ensure appropriate duct performance (duct runs should be as air tight as possible)?</p> <p>Note: All the joints should be sealed correctly either using duct tape or silicon.</p>	



Figure 1 Ductwork Visual Guide

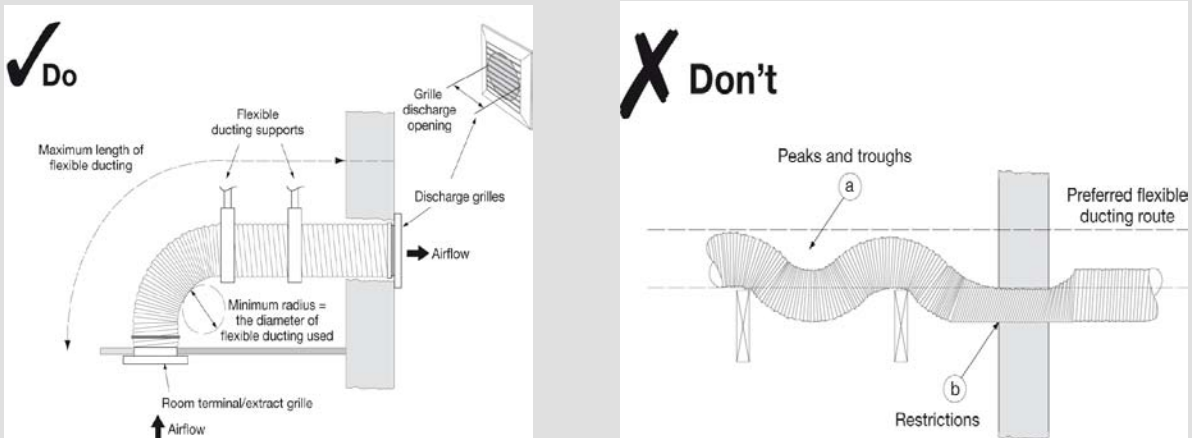

Source: Approved Document F (England & Wales) 2006

2. Unit Fixing	Decision Yes, No or N/A
Has the heat recovery unit been effectively insulated? Note: If the unit is not pre-insulated then ensure additional insulation is installed around the unit to minimise heat loss	
Has the heat recovery unit been fixed to a stable element of the building fabric (e.g. wall or floor) using manufacturer recommended/supplied fixing brackets?	
Has the condensation drain been fitted and the pipe insulated?	
Have approved acoustic/anti-vibration mountings been used? Note: Special attention is needed to avoid transmission and stress to duct joints	
Has the unit been installed in a position that will permit access for maintenance purposes?	
Have all grilles or ductwork that penetrate the building's air barrier, as identified in the construction drawings, been sealed to ensure continuity of the air barrier?	



Figure 2 Sample Mounting Positions



3. Electrical Connection	Decision Yes, No or N/A
Has the rating label been verified to establish suitability for the installation strategy and whether an earth is required (e.g. voltage, class I or II product status)?	
Has a local isolator been provided to enable the unit to be isolated for maintenance purposes?	
Has the unit been fused in accordance with its power rating?	

1. System Balancing & Calibration	Decision Yes, No or N/A
Has the air flow been checked using a proprietary device such as an anemometer (recommended)?	
Have the controls been set following a defined process? Refer to figure 3 flow diagram	
Have all distribution grilles been locked where possible to minimise unapproved occupant adjustment?	

Figure 3

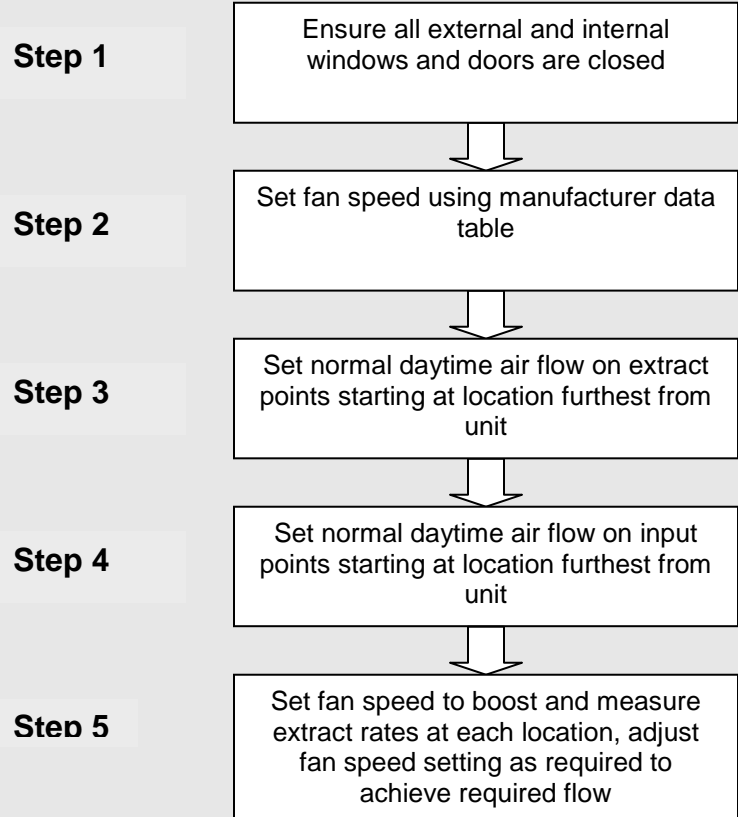

2. Handover and Control/Maintenance Advice	Decision Yes, No or N/A
Has the customer been supplied with suitable documentation detailing maintenance and operational requirements?	
Has the customer been advised that opening windows is not recommended during normal use in order to ensure the energy efficient operation and performance of the balanced system?	
Has the customer been advised not to seal natural air flows from room to room (e.g. avoid door seals and thick pile carpets)	
Has the customer been advised not to alter settings post-commissioning?	
Has the customer been advised to clean the filters as explained in the manufacturer's instructions?	