

ductmaster

NTD-125-* & NTD-204-*

Nuaire Rectangular & Round Thermal Ducting Installation Guide

1.0 Introduction

Nuaire Ductmaster Thermal Ducting (NTD) is a range of ducting and ancillaries intended for installation in domestic properties.

Nuaire Thermal Ducting is available in two different sizes and profiles, based on the internal dimension: 125mm diameter or 204 x 60mm rectangular.

Unlike other thermal ducting systems Nuaire's unique ducting design negates the need for solid plastic inner ducting to achieve the required thermal properties and leakage rates stipulated by building regulations.

Nuaire's thermal ducting clamps connect system is designed to use with Nuaire Thermal Ducting and allows quick and easy installation without the need for any tapes or sealants.

Using Nuaire thermal ducting will achieve a level of leakage substantially lower than the maximum allowed for a class A duct as defined in DW/143 (Ductwork leakage testing).

2.0 Installation

Installation must be carried out by competent personnel in accordance with the appropriate authority and conforming to all statutory governing regulations.

The ducting must be installed indoors, on a suitable vibration free solid surface away from direct sources of frost, heat, and water spray or moisture generation.

Prior to installation a dimensional check of the chosen installation location should be undertaken to ensure suitability.

IMPORTANT

Do not place heavy objects on the ducting as this could cause distortion or breakage. Distorted ducting could result in airflow leakage at the seal joint with the connector.

Fig 1. Dimensions of rectangular duct + or - 2mm.

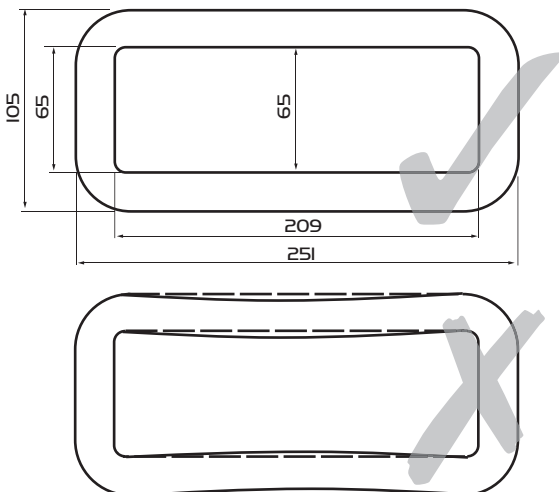

IMPORTANT

Nuaire Thermal Ducting is supplied in 1 meter lengths. If shorter lengths are required the duct can be cut to the desired length. (see page 3 fig 9).

2.1 Thermal Ducting Clamps

Nuaire thermal ducting clamps are available in 2 options to match 125mm diameter or 204 x 60mm rectangular duct. Both types are with fixing lugs or without fixing lugs.

Fig 2. Rectangular and round Thermal Ducting Clamp options.

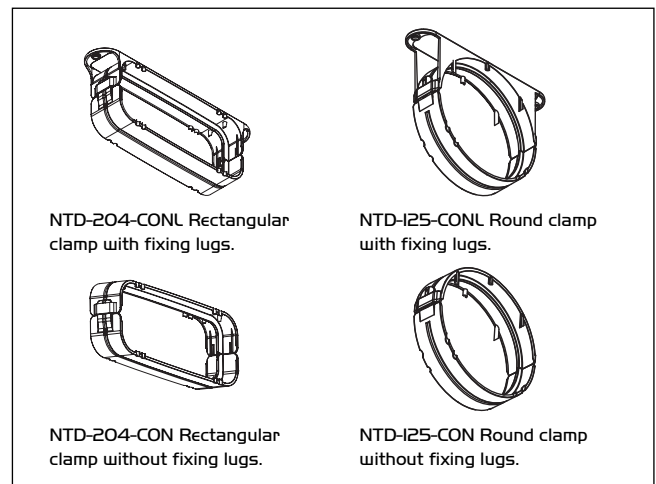

Note: Use of Thermal ducting clamps with and without fixing lugs must be used as follows on the duct bends shown below.

Fig 3. Thermal ducting clamp use.

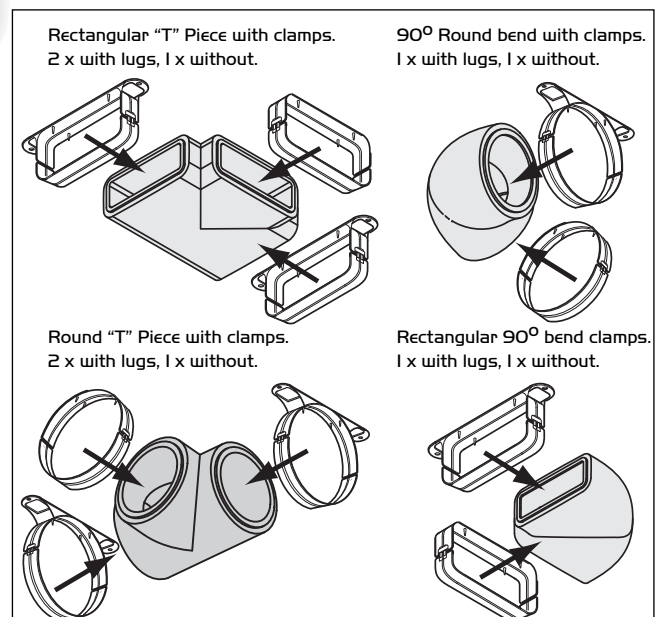

3.0 Use of flexible duct connections with thermal plenums and bends

Where it is necessary to use semi-rigid acoustic flexible duct (max length 300mm) between the MVHR unit and a plenum or bend please ensure that a rigid 125mm dia. PVC duct connector is installed into the plenum or bend for successful connection.

Fig 4. Using the PVC duct connector (code PVC593WH).

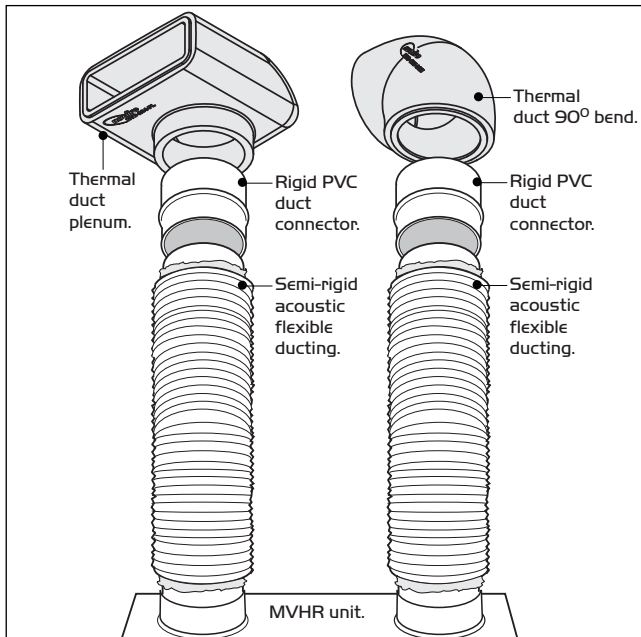

3.1 Use of flexible duct connections between air valves and plenums/bends

Fig 5. Use of standard flexible ducting (max length 300mm) between an air valve (code VS125) and plenum or bend.

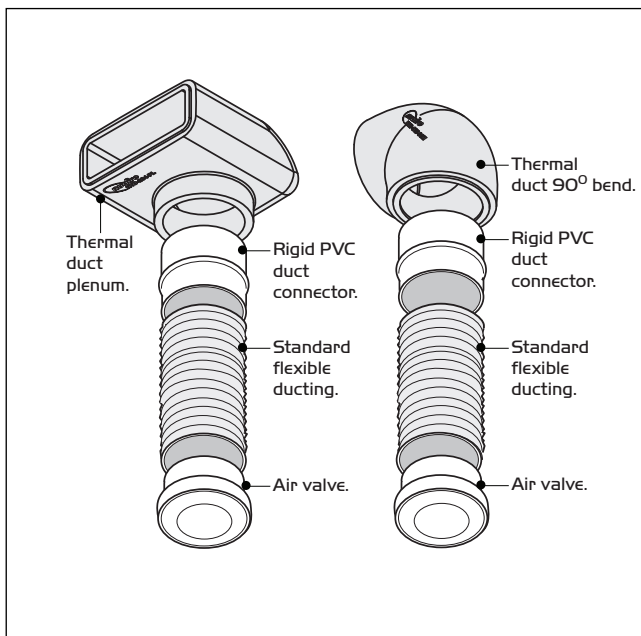

3.2 Installation of a condensation trap in thermal ducting

Fig 6. Use of condensate trap (code CONTRAPI25) with rigid PVC duct connectors (code PVC593WH).

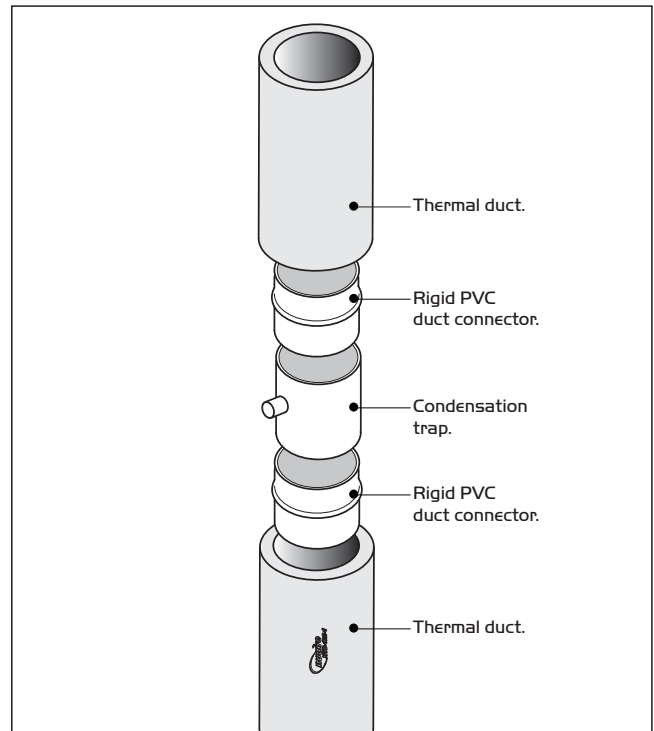

3.3 Installation of an attenuator in thermal ducting

Fig 7. Use of rectangular and round thermal duct with an attenuator.

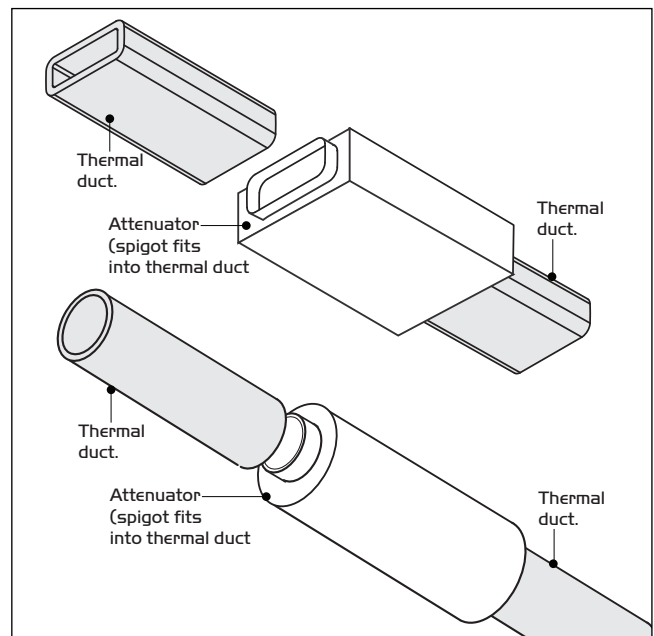

4.0 Cutting ducting lengths

A flush, square 90° cut is required to ensure that an air tight seal is made with centre ridge in the clamp. If an angled cut is made, this will not allow the duct clamps to create a seal on the duct. We advise that the duct is cut with a very sharp blade or fine toothed saw (we recommend a minimum of 14 teeth per inch). The cutting blade length should be at least the same length as the wall thickness of the ducting.

Ensure duct is placed into Duct Clamp connector prior to installation to check the squareness of the cut ducting.

Fig 9. A square 90° cut is required to ensure an air tight seal. Duct and clamp viewed from below.

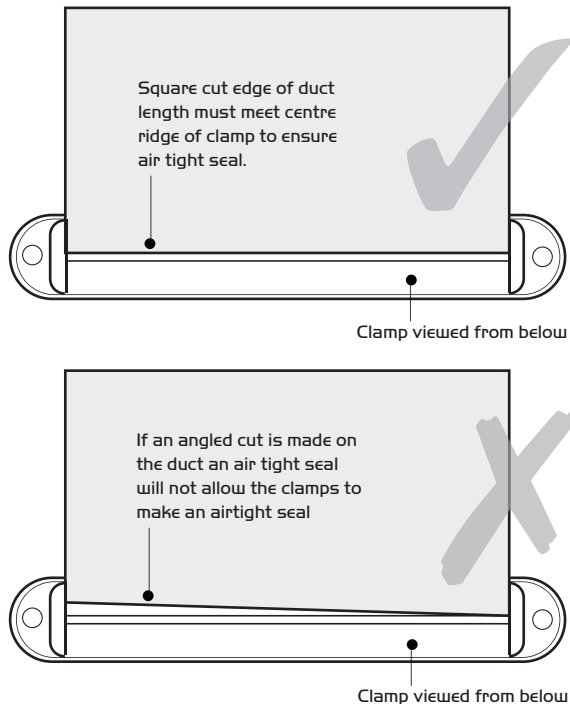

IMPORTANT

Nuair Thermal Ducting is supplied in 1 meter lengths. If shorter lengths are required the duct can be cut to the desired length with a fine toothed saw. (We recommend a minimum of 14 teeth per inch). Failure to make a square cut may result in airflow leakage when connecting to other ducting pieces. Ensure duct is placed into Duct Clamp connector prior to installation to check the squareness of the cut ducting. (see fig 9).

5.0 Fitting Clamps with fixing lugs

Note: only clamps with fixing lugs (NTD-204-CONL) and (NTD-125-CONL) should be used for fitting/securing duct to the installation surface.

Having established the installation position for the ducting and clamps with lugs, drill 2 holes to suit the clamp position.

Fig 10a. Round lugged (NTD-125-CONL) clamp features.

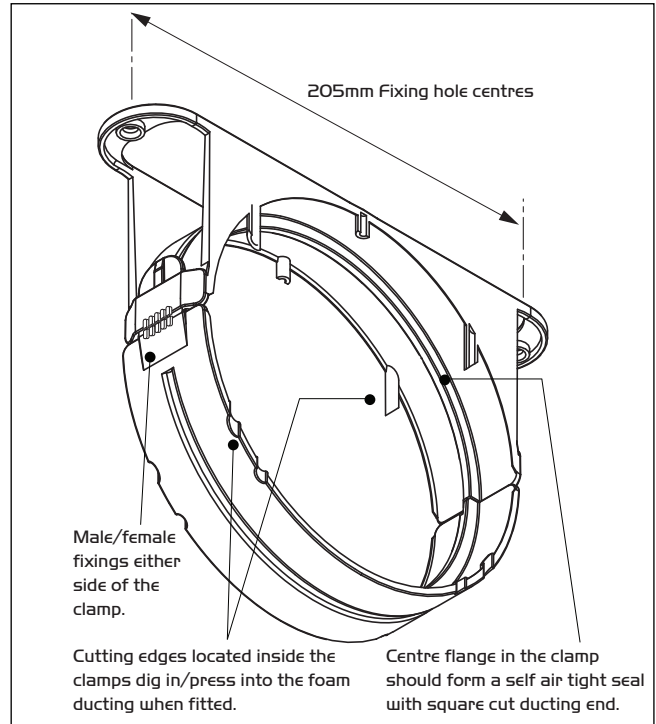
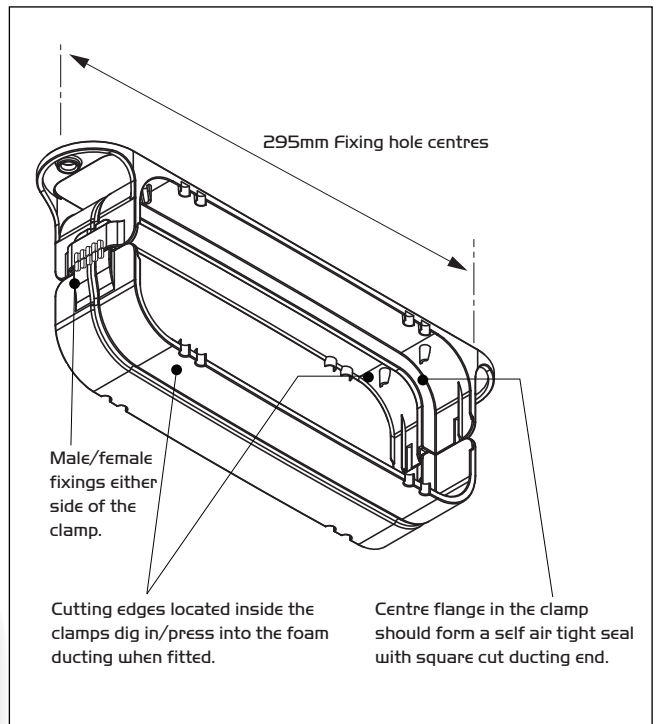

Fig 10b. Rectangular lugged (NTD-204-CONL) clamp features.



5.0 Fitting Clamps with fixing lugs

2. Having drilled 2 fixing holes to suit the clamp position, remove the top half of the clamp from the bottom half.

Fig 11a. Hole centres on round lugged clamps.

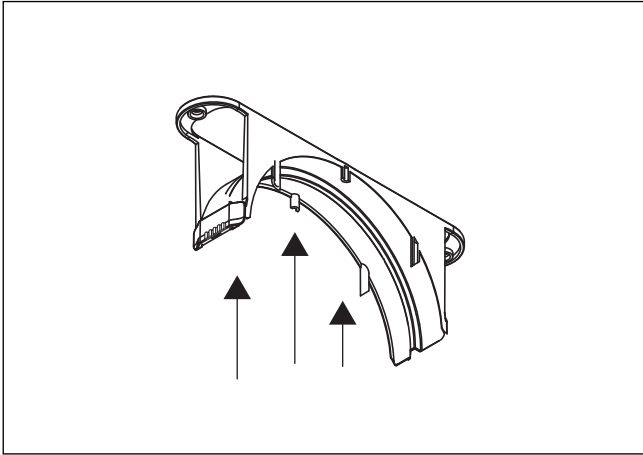

Using appropriate fixings fix the top half of the clamp to the solid surface. (Fixings supplied by others).

Fig 11b. Hole centres on rectangular lugged clamps.

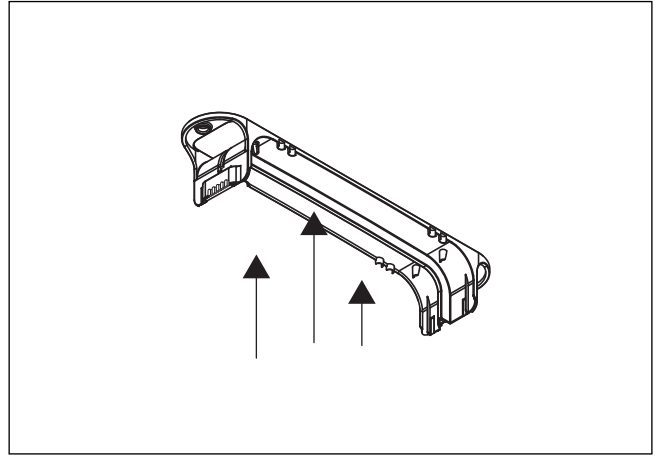

3. Fit the end of Nuairé thermal ducting into the lugged clamp. Do this by aligning the flush edge/end of the duct to the centre flange of the clamp and push duct into clamp. **Ensure the duct**

Fig 12a. Round lugged clamp and duct.

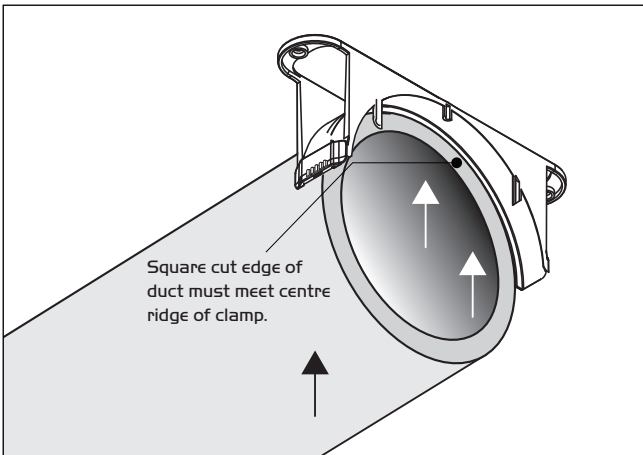

is fully pressed into the clamp allowing the fixing teeth to embed into the duct, to create an air tight seal. Failing to do so may cause air leakage. (see Fig 8).

Fig 12b. Rectangular lugged clamp and duct.

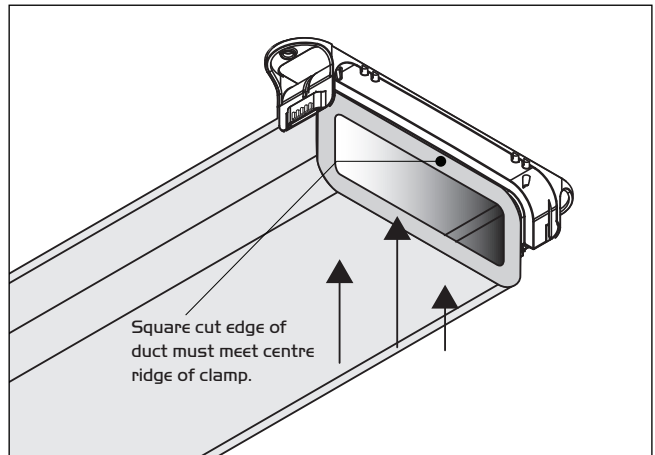

4. Insert another duct piece into the other side of the clamp. Once both sets of duct pieces are in place the male half of the clamp can be fitted. Line up the fixing tabs on the male half of

Fig 13a. Round lugged clamp and duct.

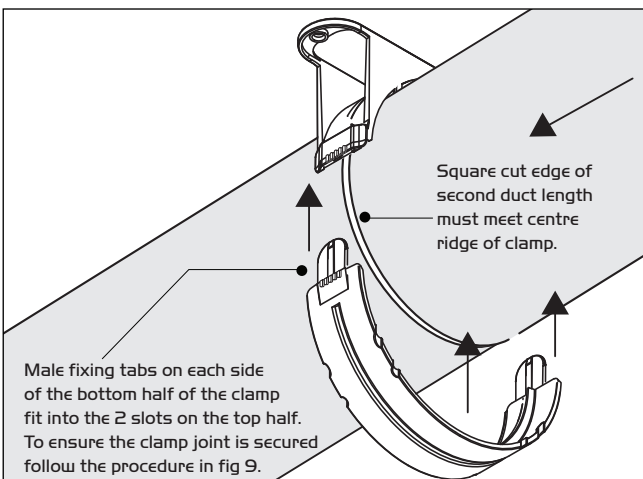

the clamp with the slots on the female half, then press together. **Ensure the ducting is fully pressed into the clamp to create an air tight seal. Failing to do so may cause air leakage.**

Fig 13b. Rectangular lugged clamp and duct.

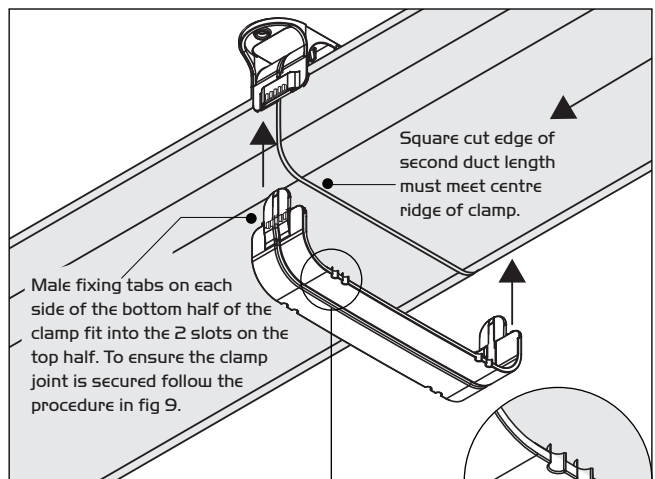

Note: ensure when fitting male/female joints together the cutting edges on the insides of the clamps dig in/press into the foam ducting.

5.0 Fitting Clamps with fixing lugs cont.

5. To ensure clamp is closed securely and the duct sealed, the use of a pinching tool/pipe grip is needed. Position the gripping mouth above and below the five raised nodules on the top and

bottom halves of the male and female parts of the clamp fixing joints. Squeeze together until a “pop” sound is heard, this confirms the correct closure has been achieved.

Fig 14.

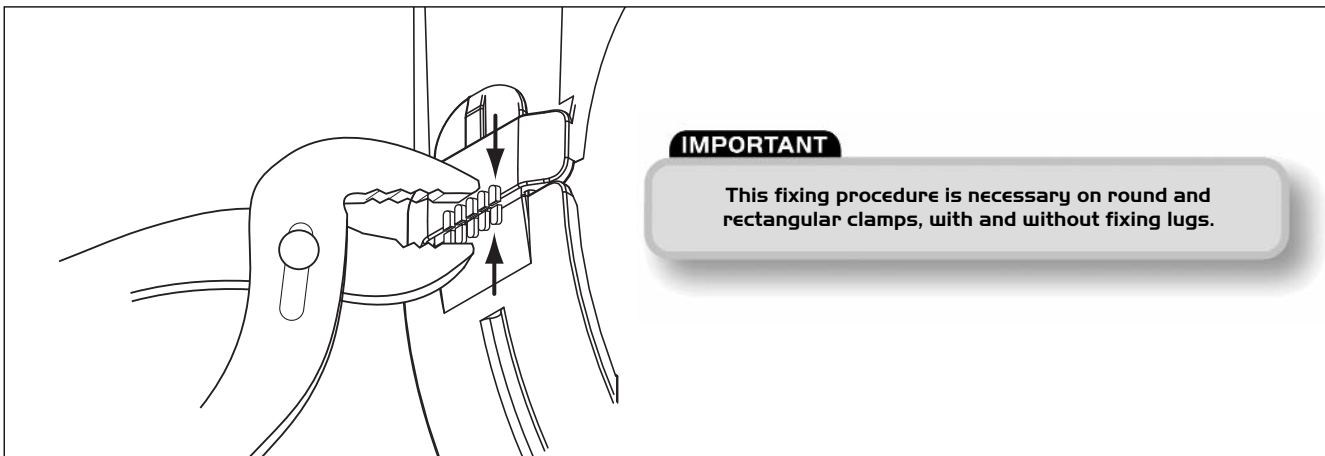

Fig 15a. Lengths of round duct installed with lugged clamp.

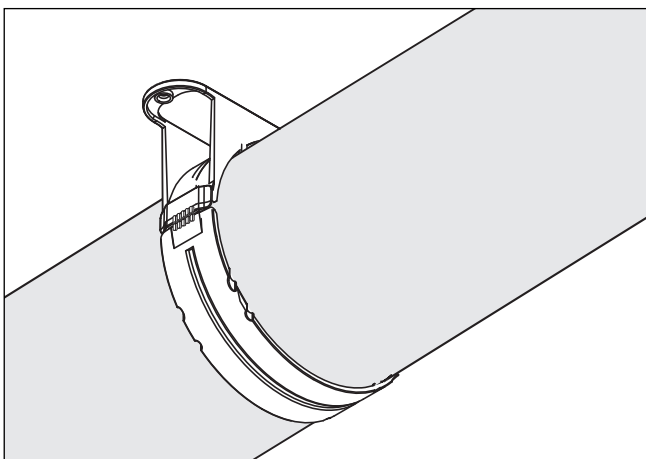
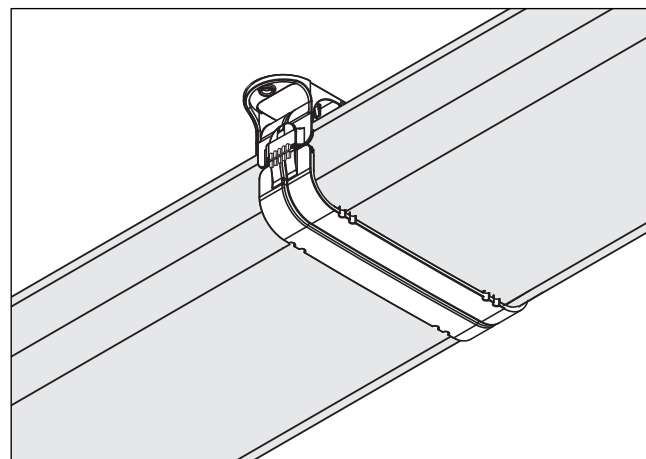

Fig 15b. Lengths of rectangular duct installed with lugged clamp.



6.0 Fitting Clamps without fixing lugs

Note: The clamps without fixing lugs (NTD-204-CON) and (NTD-125-CON) should only be used to connect two ducting items together, they should not be used for installing duct to any surface.

Fig 16. Note: If lugged clamps cannot be used to support ducting, PVC banding should be used at least every 1m for fixing. This applies to both round and rectangular ducting.

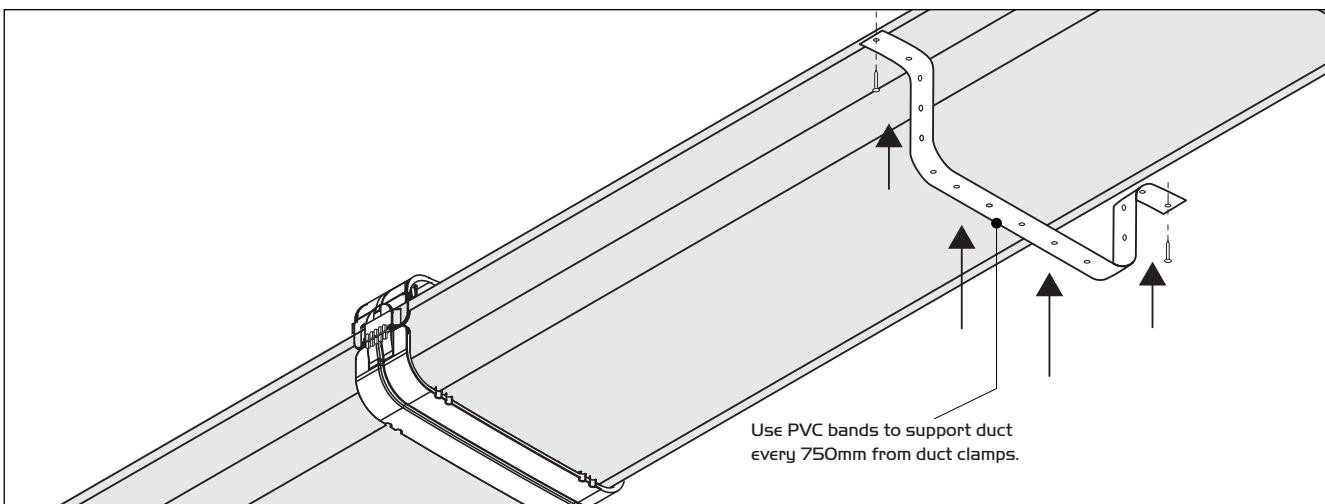

7.0 Typical MVHR ducted arrangement using insulated and uninsulated 204 x 60mm ducting

Fig 17.

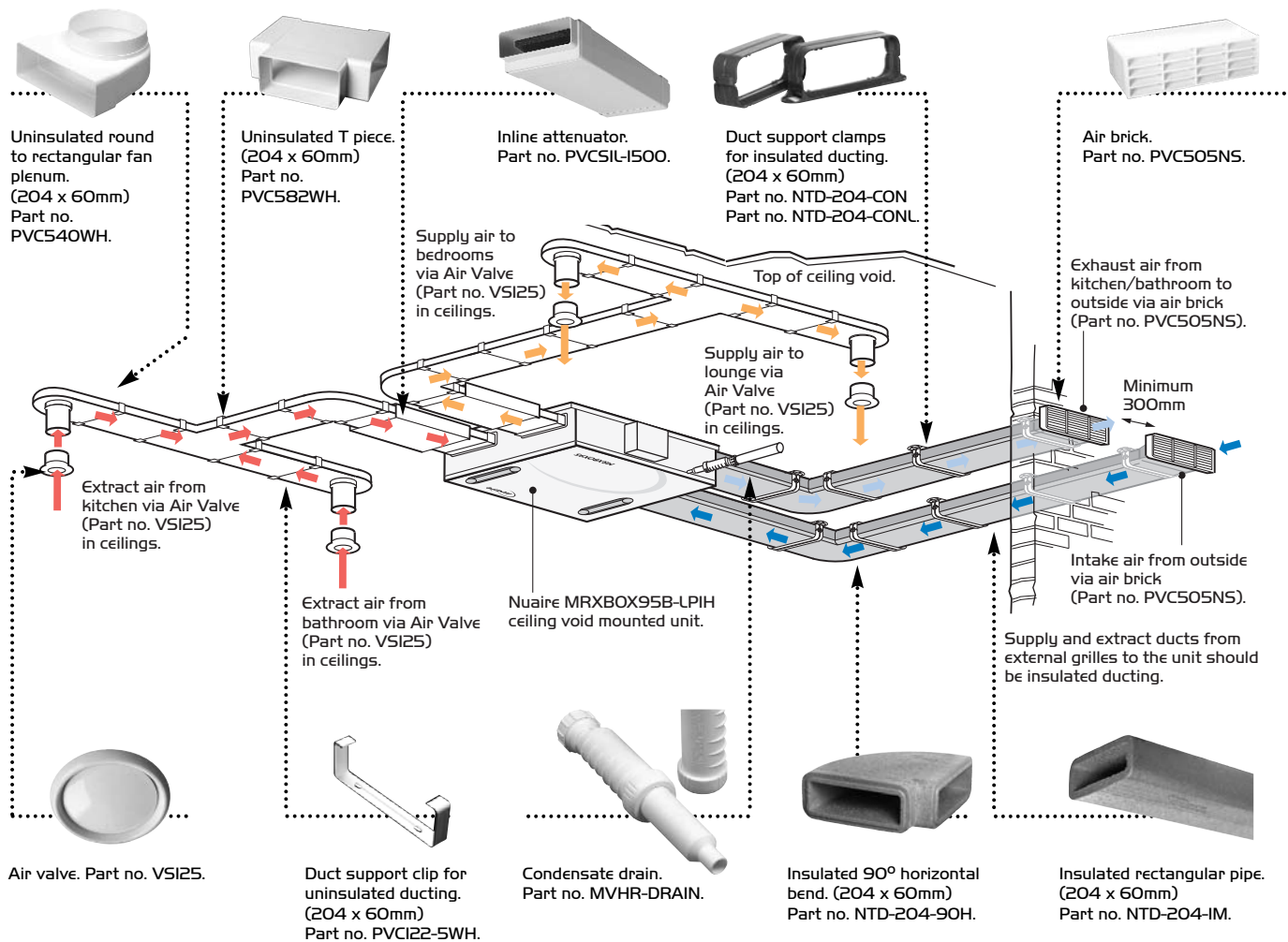

8.0 Installing a fire sleeve with 125mm dia. thermal ducting

Fig 18. Ducting and fire sleeve set-up. **Note: Rectangular 204mm x 60mm thermal ducting requires the same process, with a fire wrap and PVC ducting needing to be applied.**

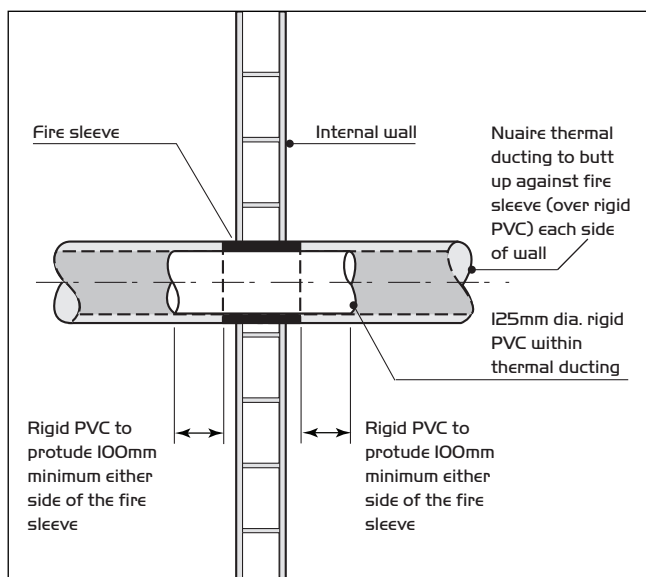

9.0 Replacement of Parts

Should any ancillary need replacing, Nuairé keep extensive stocks for quick delivery.

When ordering spare parts, please quote the product code embossed on each ancillary component.

10.0 Warranty

The 5 year warranty starts from the day of delivery and includes parts and labour for the first year and parts only for the remaining 4 years. This warranty is conditional on planned maintenance being undertaken.

11.0 Service Enquiries

Nuairé can assist you in all aspects of service. Our Technical Support department will be happy to provide any assistance required.

**Technical Support
on 029 2085 8444**

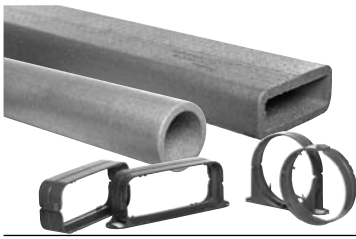

ductmaster

NTD-125-* and NTD-204-*

Nuaire Rectangular & Round Thermal Ducting

Range Details 204 x 60mm Ducting

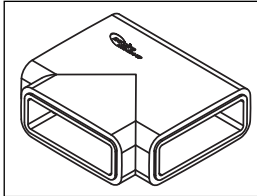

INSULATED "T" PIECE

Part Number	Duct Size	Box Description	Box Quantity	Resistance in PA				
				@8l/s	@13l/s	@21l/s	@29l/s	@37l/s
NTD-204-TP	204mm x 60mm	Insulated T Piece	6	0.9	2.3	5.9	11.2	18.3

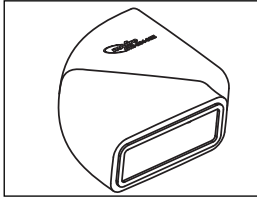

INSULATED 90° HORIZONTAL BEND

Part Number	Duct Size	Description	Box Quantity	Resistance in PA				
				@8l/s	@13l/s	@21l/s	@29l/s	@37l/s
NTD-204-90H	204mm x 60mm	Insulated 90° Horizontal Bend	6	0.6	1.6	4.1	7.9	12.8

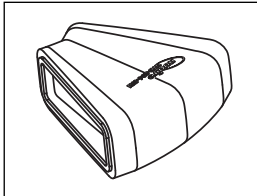

INSULATED 45° HORIZONTAL BEND

Part Number	Duct Size	Description	Box Quantity	Resistance in PA				
				@8l/s	@13l/s	@21l/s	@29l/s	@37l/s
NTD-204-45H	204mm x 60mm	Insulated 45° Horizontal Bend	6	0	0.3	1.2	2.6	4.5

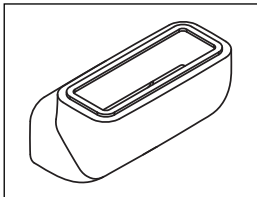

INSULATED 90° VERTICAL BEND

Part Number	Duct Size	Description	Box Quantity	Resistance in PA				
				@8l/s	@13l/s	@21l/s	@29l/s	@37l/s
NTD-204-90V	204mm X 60mm	Insulated 90° Vertical Bend	6	0.7	1.9	5.2	10.1	16.6

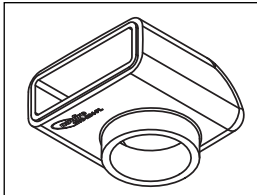

INSULATED PLENUM

Part Number	Duct Size	Description	Box Quantity	Resistance in PA				
				@8l/s	@13l/s	@21l/s	@29l/s	@37l/s
NTD-204-PL	204mm x 60mm	Insulated Plenum	6	0.5	1.3	3.4	6.4	10.4

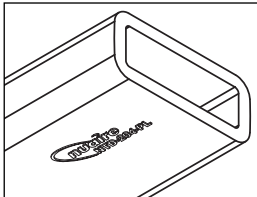

INSULATED DUCT IM LENGTH

Part Number	Duct Size	Description	Box Quantity	Resistance in PA				
				@8l/s	@13l/s	@21l/s	@29l/s	@37l/s
NTD-204-IM	204mm x 60mm	Insulated Duct IM length	6	0.2	0.4	0.8	1.4	2.2

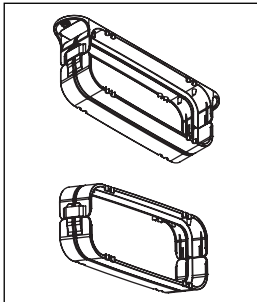

RECTANGULAR DUCT CLAMPS FOR INSULATED DUCT

Part Number	Duct Size	Description	Box Quantity	Resistance in PA				
				@8l/s	@13l/s	@21l/s	@29l/s	@37l/s
NTD-204-CONL	204mm x 60mm	Insulated Duct Clamps with Fixing Lugs	6	-	-	-	-	-
NTD-204-CON	204mm x 60mm	Insulated Duct Clamps without Fixing Lugs	6	-	-	-	-	-

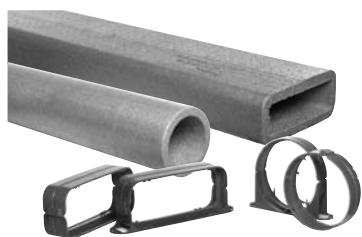

ductmaster

NTD-125-* and NTD-204-*

Nuaire Rectangular & Round Thermal Ducting

Range Details 125mm dia. Ducting

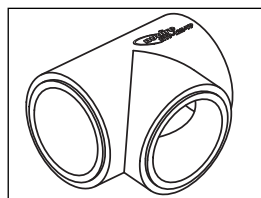

INSULATED T PIECE

Part Number	Duct Size	Description	Box Quantity	Resistance in PA				
				@81/s	@131/s	@211/s	@291/s	@371/s
NTD-125-TP	125mm Dia.	Insulated T Piece	6	0.5	1	2.2	3.9	6.1

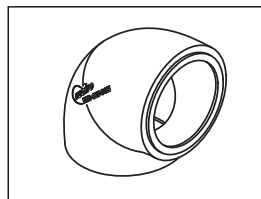

INSULATED 90° BEND

Part Number	Duct Size	Description	Box Quantity	Resistance in PA				
				@81/s	@131/s	@211/s	@291/s	@371/s
NTD-125-90H	125mm Dia.	Insulated 90° Bend	6	0.5	1.4	4	7.9	13

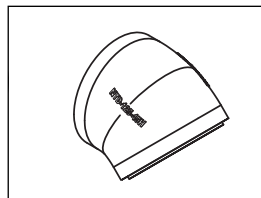

INSULATED 45° BEND

Part Number	Duct Size	Description	Box Quantity	Resistance in PA				
				@81/s	@131/s	@211/s	@291/s	@371/s
NTD-125-45H	125mm Dia.	Insulated 45° Bend	6	0.2	0.5	1.4	2.7	4.5

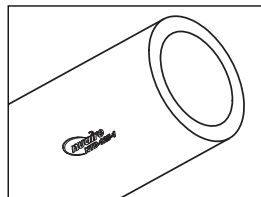

INSULATED DUCT IM LENGTH

Part Number	Duct Size	Description	Box Quantity	Resistance in PA				
				@81/s	@131/s	@211/s	@291/s	@371/s
NTD-125-IM	125mm Dia.	Insulated Duct IM length	6	0.1	0.2	0.4	0.65	0.9

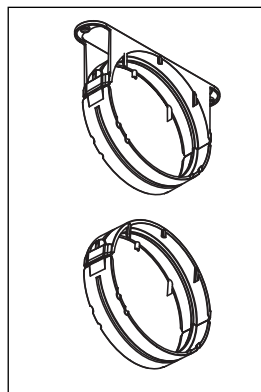

ROUND DUCT CLAMPS FOR INSULATED DUCT

Part Number	Duct Size	Description	Box Quantity	Resistance in PA				
				@81/s	@131/s	@211/s	@291/s	@371/s
NTD-125-CONL	125mm Dia.	Insulated Duct Clamps with Fixing Lugs	6	-	-	-	-	-
NTD-125-CON	125mm Dia.	Insulated Duct Clamps without Fixing Lugs	6	-	-	-	-	-

Technical or commercial considerations may, from time to time, make it necessary to alter the design, performance and dimensions of equipment and the right is reserved to make such changes without prior notice.