

Shared Details: NOR350 Fitting Components

1. Fitting the Top Centre Pivot

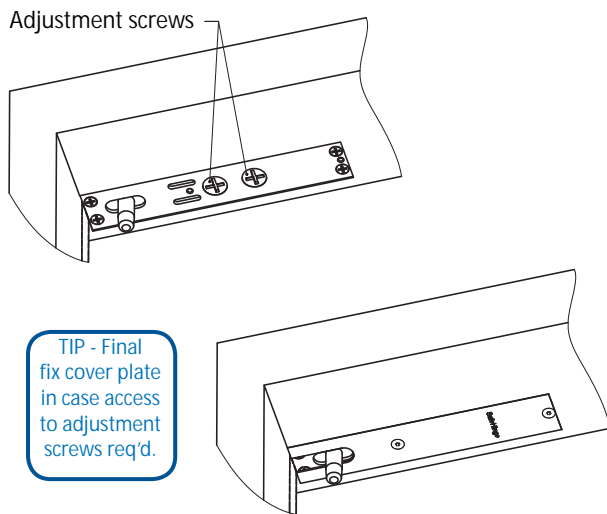
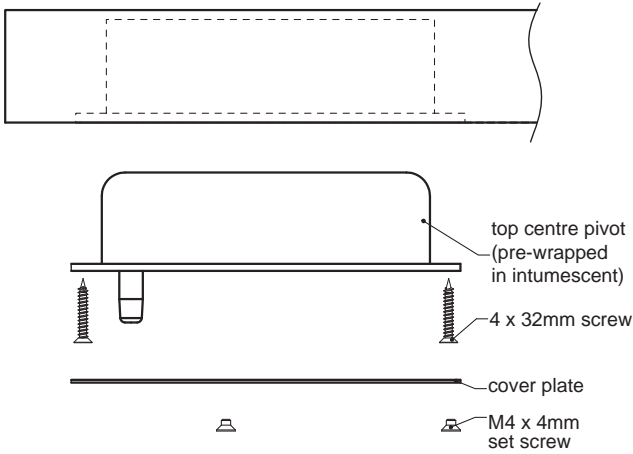

i) Ensure the intumescent wrap is inserted into the mortice or present around the top centre pivot mechanism.

ii) Use supplied 4No. 4 mm x 32 mm screws to fit the top centre to the frame.

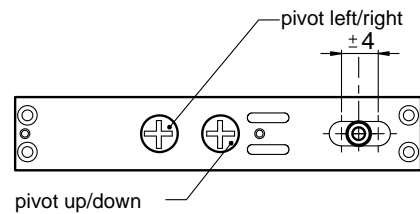

iii) Use supplied 2No. M4 x 4 mm set screws to fit the cover plate.

2. Fitting the Aluminium Edge Profiles

NOR350 44mm

Intumescent supplied loose. Fit for FD30 rating.

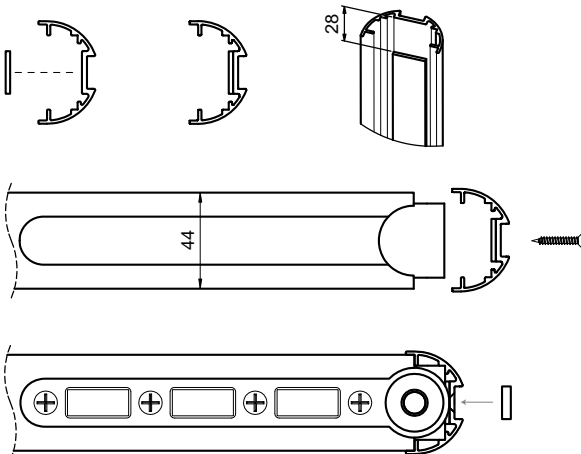

NOR350 54mm

Intumescent behind profile comes pre-fitted as standard

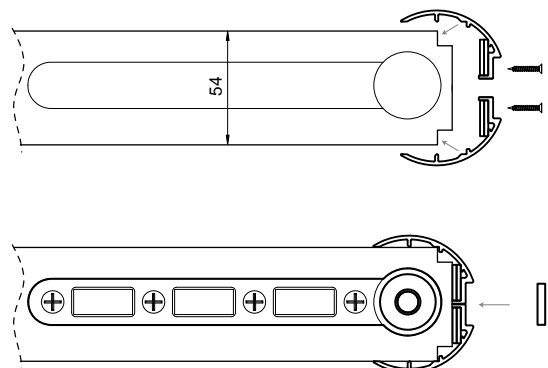

Undercuts & Floor Pivot Adjustment

The flooring configurations shown in the following section should be regarded as illustrative only.

Standard Undercut

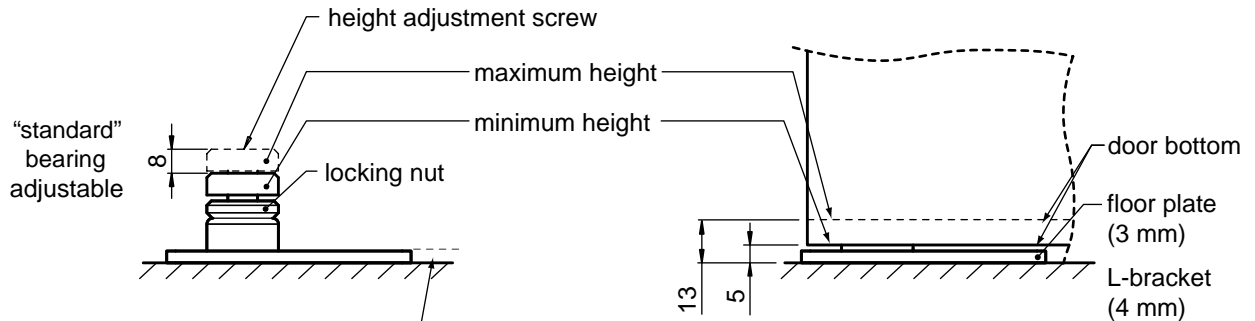

The "standard" bearing is supplied with all regular Safehinge kits.

Large Undercut Option A

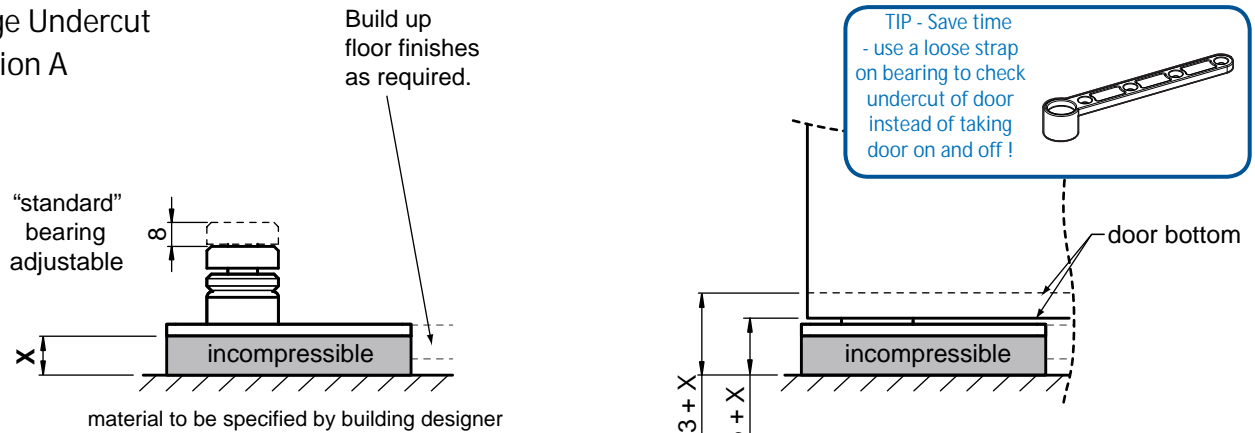

The "standard" bearing is supplied with all regular Safehinge kits.

Large Undercut Option B

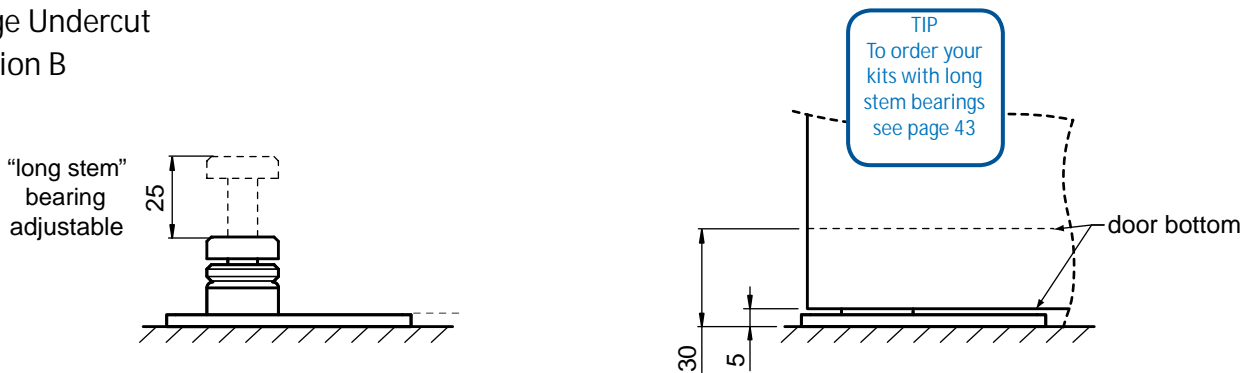

Sizing Door Stops to Perfection

The hanging side stop is not always the same width as the head stop because of the important finger-safe 2-3mm gap between aluminium profile and stop.

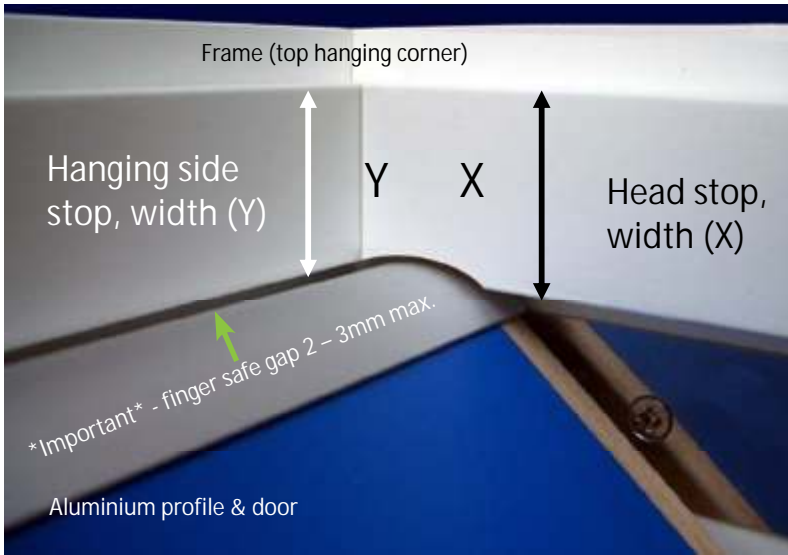

Helpful gap check!



50 pence coin DOES fit



1 pound coin DOES NOT fit

NOR350 (44 mm) Hanging Side Stop

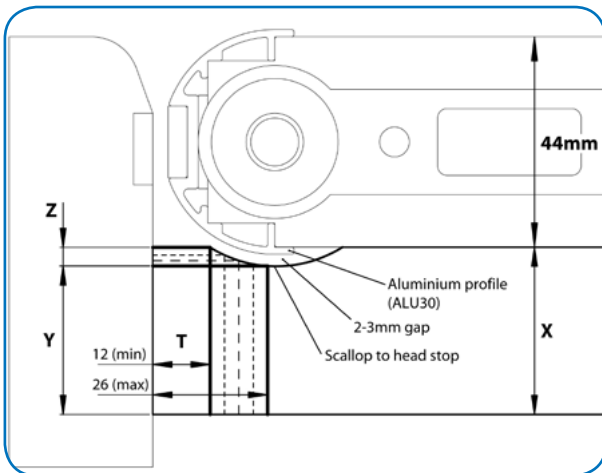

$$Y = X - Z$$

T (mm) stop thickness	Z (mm)
12	0
15	2
18	3
21	4
26 (max for hanging stop)	4

Example: If head stop is 35x15 mm, then

X = 35 mm T = 15 mm.

Z = 2 mm (taken from table)

$$Y = X - Z$$

$$Y = 35 - 2 = 33 \text{ mm}$$

TIP
Use pinned door stops. These can be moved if req'd.

NOR350 (54 mm) Hanging Side Stop

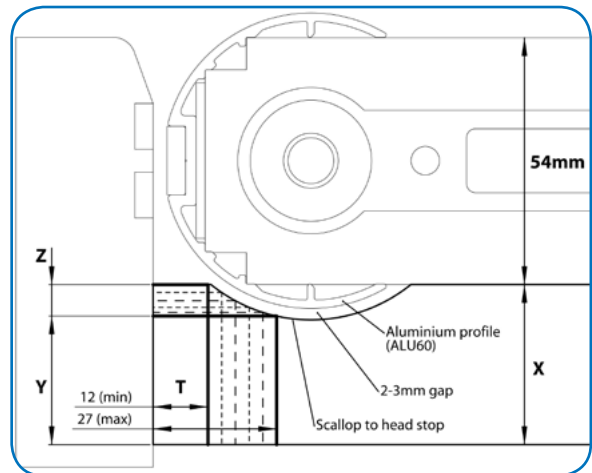

$$Y = X - Z$$

T (mm) stop thickness	Z (mm)
12	0
15	2
18	3
21	5
24	6
27 (max for hanging stop)	7

Example: If head stop is 40x18 mm, then

X = 40 mm T = 18 mm.

Z = 3 mm (taken from table)

$$Y = X - Z$$

$$Y = 40 - 3 = 37 \text{ mm}$$

Opening Angle Limit

All pivot doors - whether NOR350 or not - have a maximum opening angle beyond which they will "bind" on the door frame. It is strongly recommend that measures are taken to prevent binding from occurring.

Recommended stop angle: 100°
(Maximum opening angle: 110°)

TIP
Limiter stay
can be used as
alternative to
door stop.

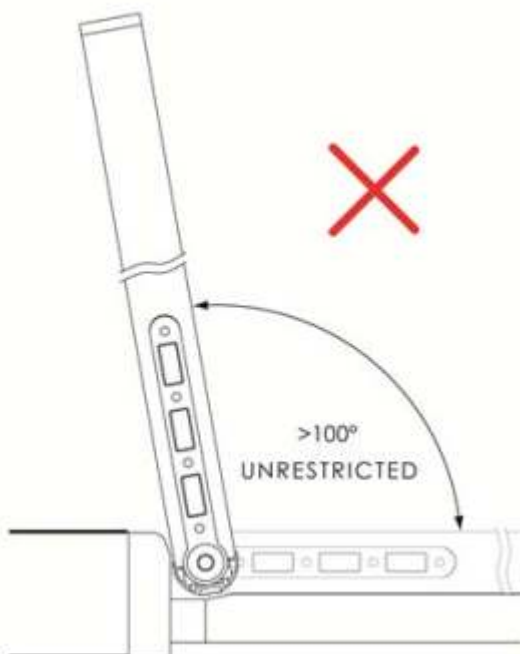
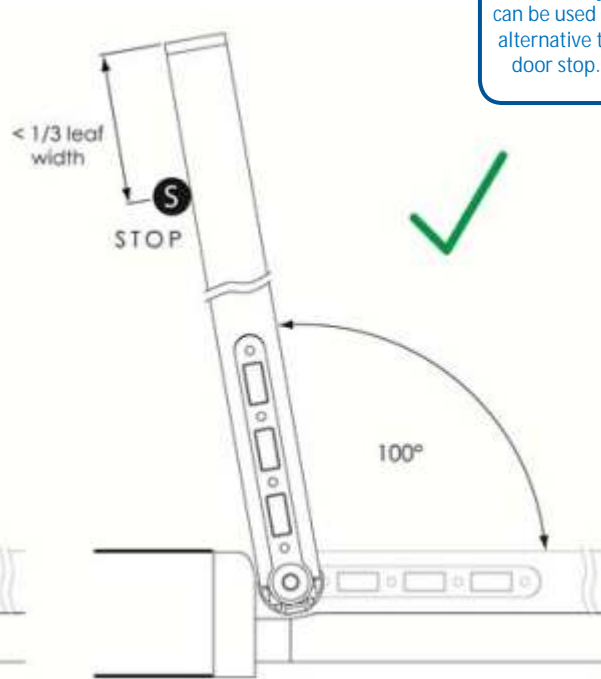
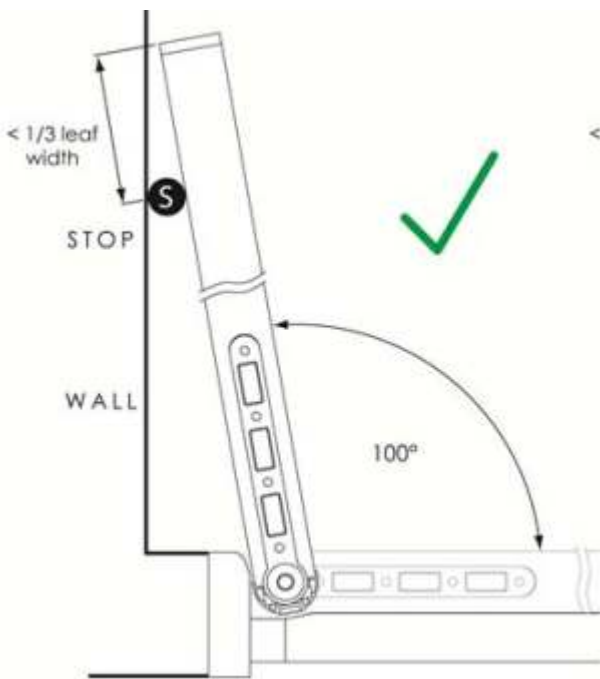

WARNING - Door binding on frame exerts extreme force on door, frame and ironmongery and may lead to damage/failure.

Door closer with back check improves situation, but should not be used in place of door stop or limiter stay.

Installation Instructions

Step 1 - Install Frame

Install the frame assembly into the structural opening. For fire, smoke and acoustic doors, pack the gap between the door assembly and the wall in accordance with BS8214:2008 and ASDMA Best Practice Guide to Timber Fire Doors. Take particular care to ensure hanging jamb is set straight as this will influence the finger-safe gap between the door and the frame.

Step 2 - Positioning of Bottom Pivot

Position the bottom pivot (floor plate or L-bracket) as directed.

Use the supplied screws and plugs to fix the bottom pivot in position. Always fix the L-bracket to both floor and frame.

IMPORTANT: Care should be taken to position correctly as this will influence the finger-safe gap between the door and the frame.

Recommended to rebate the bottom pivot into the floor to eliminate a minor trip hazard.

Step 3 – Height Adjustment of Bottom Pivot

Determine the desired gap at the threshold and then set the height of the pivot bearing accordingly.

IMPORTANT: Ensure the thread of pivot bearing is securely engaged with the threaded boss bottom pivot. After height adjustment has been made, securely tighten locking nut against thread. This will require a flat head screwdriver and spanner.

Step 4 – Prepare the Top Centre Pivot

Remove and store the top centre cover plate (if fitted). Check that the pivot pin is fully retracted and central (not positioned to the Left or Right extremes).

IMPORTANT: Do not operate the adjustment screws with power tools.

Step 5 – Hanging the Door

IMPORTANT: It is Recommended to follow Health and Safety Executive guidelines when lifting (www.hse.gov.uk)

With the door in a 90° open position and tilted slightly, lift the door and carefully locate the bottom strap cup onto the pivot bearing. When this has been located, raise the door to align the retracted top centre pivot pin with the top strap bearing (NOTE - it can help to mark the pivot centre of strap on the door edge to help align when hanging.). Extend the pivot pin to locate it in the bearing.

IMPORTANT: Ensure the pin is fully extended and securely located in the top strap bearing (this requires approximately eight full turns of the “retract/extend” adjustment screw). Additionally, on the top centre adjustment ruler, look for the markers - these should be visible when the pin is fully down.

If required, a half turn in the “retract” direction (after fully extending) can ease the “hanging edge gap” adjustment screw.

Step 6 – Check Threshold Gap

Check the gap at the threshold hanging side is as required. If height adjustment is necessary, remove the door, adjust the floor plate and then re-hang the door in accordance with Steps 3 – 5.

Step 7 – Set the Finger-Safe Gap

The finger safe gap (hanging edge) should be 2-3 mm. Adjust the “pivot left/right” adjustment screw on top centre until this dimension is achieved at the top of the door. Check the gap is consistent the full height of the door (test as shown on page 40).

Step 8 – Check Swing

Check the door is swinging correctly. Check that gap sizes around the perimeter are correct and that there is no excessive rubbing on the hanging side. Make necessary adjustments. Fix the cover plate in position over the top centre pivot when complete.