



**NeoTimber<sup>®</sup>**  
COMPOSITE DECKING

**INSTALLATION AND  
CARE GUIDE**

# TABLE OF CONTENTS

## Pre-Installation Guide

Handling Your Decking	03
Tools For The Job	04
Elements To Consider	05

## Installation Guide

Subframe Installation	
Subframe Options	08
Using NeoTimber Composite Joists	10
Using NeoTimber Adjustable Pedestals	14
Using NeoTimber Plastic Joists And Posts	19

## Deck Board And Trim Installation

Fitting NeoTimber Deck Boards	24
Fixing NeoTimber Trims	27

## Design Considerations

Picture Framing	29
Decking Steps	33

## Care Guide

Routine Cleaning	38
Stubborn Spot Stains	38
Surface Mildew And Mould Growth	38
Water Staining	39
Clearing Ice And Snow	39



This installation guide is purely a guidance document on how to install NeoTimber products. We understand that not every project will use all of the products outlined, but we recommend that key elements should be followed regardless of the chosen sub-structure solution.



NeoTimber<sup>®</sup>  
COMPOSITE DECKING

## PRE-INSTALLATION

Key areas should be considered prior to embarking on the installation of your NeoTimber deck boards and ancillary products. This section shall cover advice on handling, recommend tools for the job and a selection of important elements to consider ahead of installation.

# PRE-INSTALLATION HANDLING YOUR DECKING

- Ensure a suitable, flat area is cleared to lay your decking prior to installation. Laying your deck boards and any accompanying products on wooden battens at approximately 400-500mm centres will ensure that the boards avoid any sitting water, dirt or grit that may scratch or damage the boards ahead of installation.
- When storing your boards outside for an extended period of time, be sure to cover them with a layer of sheeting.
- Take extra care when lifting, moving or fitting boards to avoid accidental scratching. Do not drag, slide or drop boards when laying over one another.
- Keeping your work area as tidy as possible will help to keep the surface of the boards free of any construction debris.

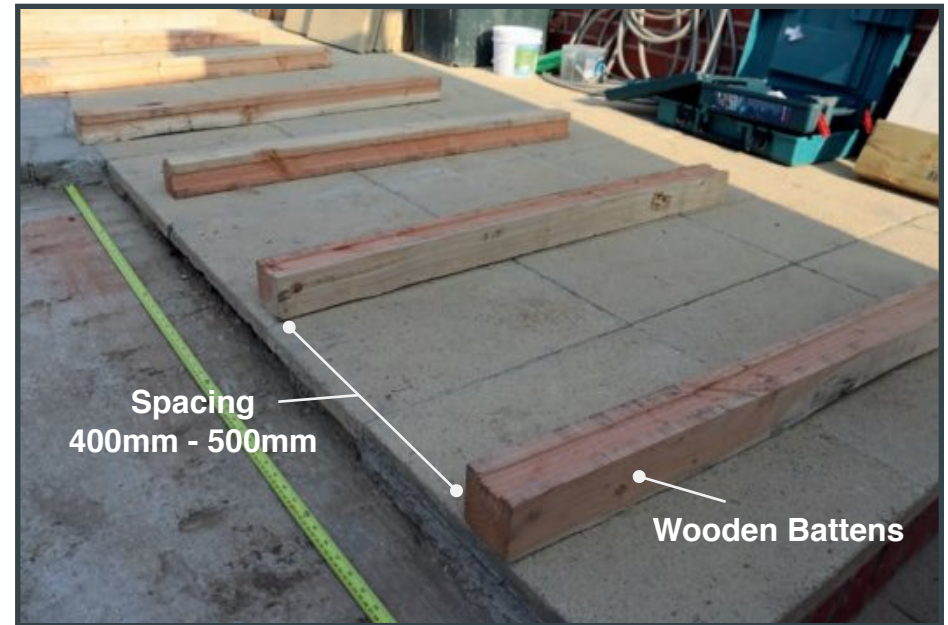

## NeoTimber Advice

### How Temperature Can Affect Your Decking

Composite materials are receptive to temperature. Allow a period of at least 24 hours prior to installation for your deck boards to climatise to the outside environment.

# PRE-INSTALLATION TOOLS FOR THE JOB

## RECOMMENDED TOOLS



HAMMER DRILL



HAND DRILL



TAPE MEASURE



PENCIL OR CHALK



JIG SAW



CIRCULAR / MITRE SAW



SPIRIT LEVEL



CARPENTRY SQUARE

## SAFETY & PPE



EAR PROTECTION



SAFETY GLASSES



SAFETY GLOVES



LONG SLEEVES



DUST MASK



SAFETY FOOTWEAR

## TOOL TIPS

- Standard wood working tools can be used with NeoTimer decking.
- We recommend carbide-tipped blades for the cleanest saw cuts. When using circular saws we recommend a 40-50 teeth blade.
- Use a 3mm drill bit for countersinking.
- If you are unsure on how to use a specific tool, please consult the tool manufacturer's user manual.

# PRE-INSTALLATION ELEMENTS TO CONSIDER

## Pre-Planning

The size, shape and orientation of your decking area should be considered in the early phases of your project. You will need to establish your chosen laying pattern as this will dictate the placement of your joists and the placement of joins if necessary.

Also factor in any fixed elements such as drains, walls, fences and door openings when planning the height, shape, location and orientation of your decking project.

## Subframe Options

Our decking system should not be installed without a framework in place. All deck boards must be installed directly onto a subframe of composite, plastic, timber or metal joists. Allow a minimum of 35mm space beneath the decking subframe to ensure adequate airflow beneath the structure.

## Temperature

Composite decking naturally contracts and expands in varying temperatures. Our FastClip installation system allows for adequate side-to-side spacing to manage these effects. However, it is advised that suitable gaps should be maintained at end-to-end joins as outlined in adjacent illustration and table.

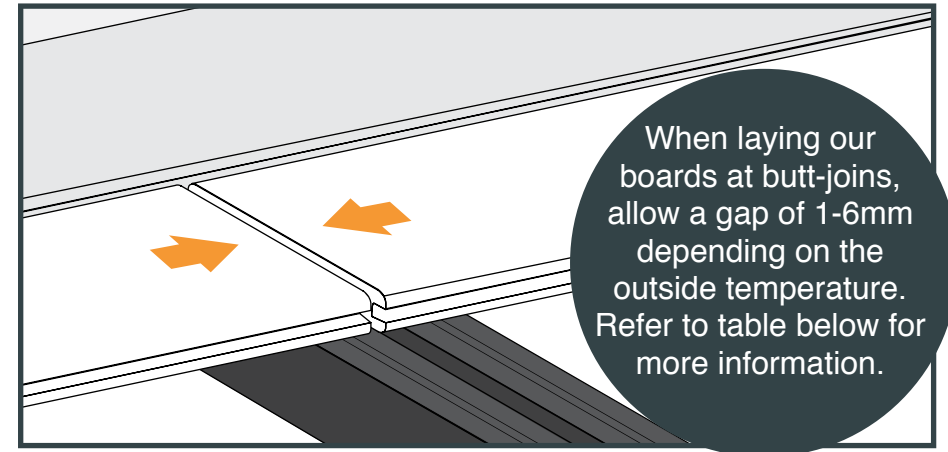

TEMPERATURE GUIDANCE TABLE	
Outside Temperature	End-To-End Gap
Below 4°C	6mm
Between 4°C - 25°C	3mm
26°C or over	1mm

## Colour Characteristics

### Traditional Composite Decking

Our traditional composite deck boards (NeoTimber Essential and Classic ranges) shall undergo a level of weathering (lightening-up) within the opening 3-6 months of installation. This initial weathering process is a result of the boards reacting to UV rays. Once this process has taken place, the rate of change will be nominal.

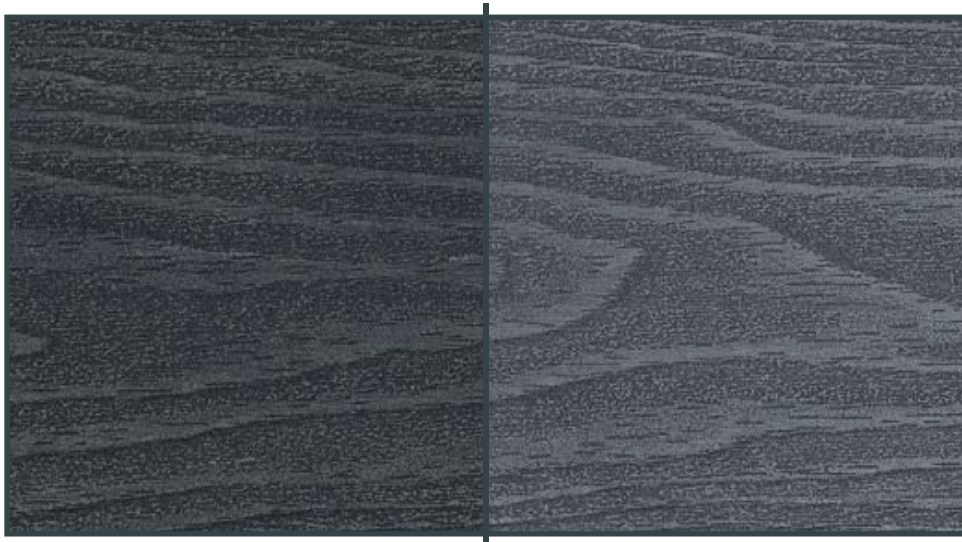

You may also notice a colour contrast between the skirting/corner trims and your deck boards especially if you are installing the boards wood-grain side up. Once the boards find their weathered colour-tone, the contrast will be more subtle.

### Capped Composite Decking

Our capped composite deck boards (NeoTimber Advanced and Deluxe ranges) come equipped with a protective polymer shell, ensuring high UV and fade resistance. They have been designed to have a high quality dual-toned appearance. The colour tone of these boards shall slightly vary from board-to-board in order to mimic a more authentic, real woodgrain finish. Consideration of this should be taken upon installation.



#### NeoTimber Advice

#### Account For Wastage

We recommend that you allow for a 5-10% wastage allowance. A 15% allowance is advised when laying boards in a diagonal pattern or angled orientation.



## INSTALLATION SUBFRAME OPTIONS

Decking environments can be diverse and varied, and unfortunately there is not a “one size fits all” subframe solution. Subsequently - we have developed the following three core installation options for customers to use in conjunction with our fixing clips and boards.

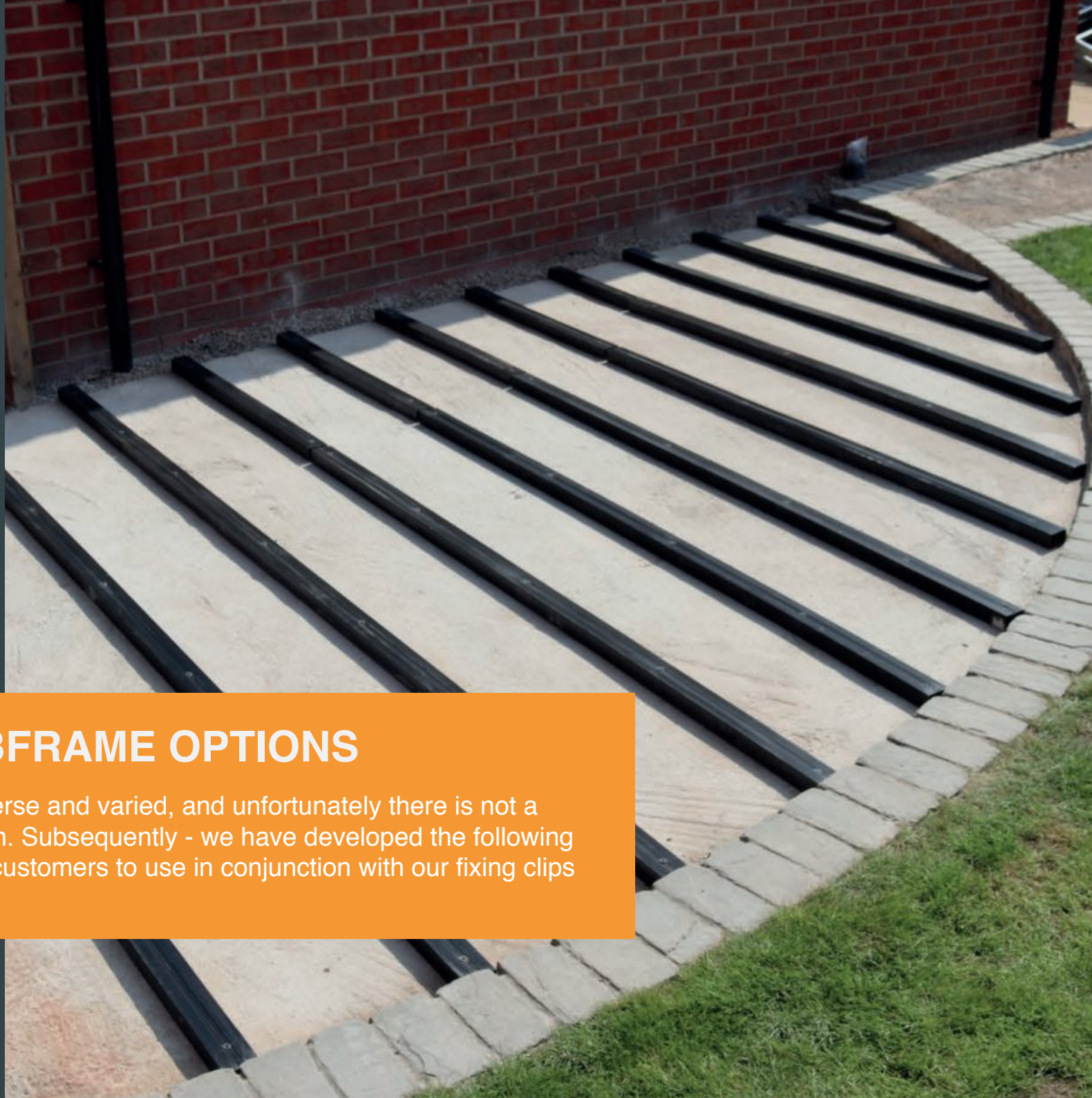

# INSTALLATION **SUBFRAME OPTIONS**



## **Using Composite Joists**

Our Composite Joists are a moisture-resistant, long-life subframe alternative to timber. This low load-bearing solution is designed to be installed directly onto a solid, flat concrete base.



## **Using Adjustable Pedestals**

Our Adjustable Pedestals are designed to elevate a decking subframe without the use of posts. Usually used on roof terrace installations and those with solid flat foundations.



## **Using Plastic Joists And Posts**

Our Plastic Lumber is apt for low-lying and raised decking projects that require a Joist and Post network. This solution is especially effective in areas with sloped and uneven ground.

Not sure which installation option is right for your project?  
Contact a member of our experienced NeoTimber sales team on 01509 323 170 who can help.



## INSTALLATION USING OUR COMPOSITE JOISTS

This section of the guide shall outline how we recommend fixing the NeoTimber Composite Joists onto a solid, flat base, to form a low-lying subframe.



# INSTALLATION COMPOSITE JOISTS

## Our Composite Joists

NeoTimber Composite Joists are designed to be installed directly onto a solid concrete base. This low-load bearing subframe option is made from a similar material as our composite deck boards and is a moisture-resistant, long-life alternative to timber joists.



### NeoTimber Advice

#### Alternative Subframe Options

Composite Joists are a recommended NeoTimber solution for installing our boards onto solid, flat foundations. However, customers can also use plastic, timber or metal joists as a subframe alternative.

# INSTALLATION COMPOSITE JOISTS

## 1 Begin With The Base

Your concrete base should have a minimum thickness of 60mm and have a slight decline to allow for drainage. You may also wish to add drainage holes to the base. We recommend an 80mm hole every 4 square metres (4m<sup>2</sup>).

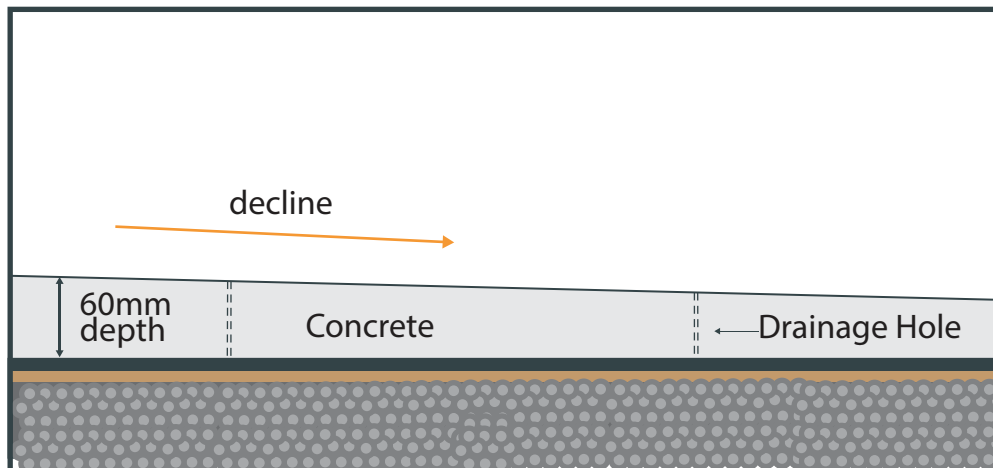
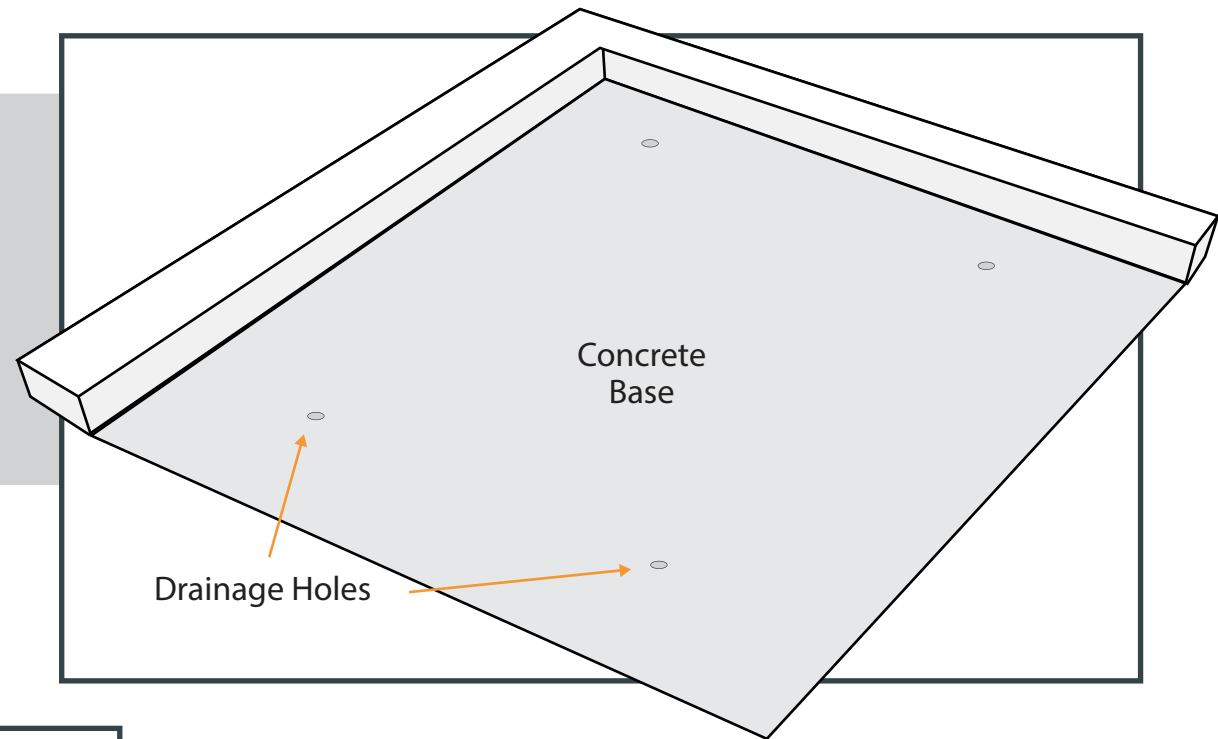

### NeoTimber Advice

#### Incorporate A Decline To Aid Drainage

In order to reduce the level of sitting water underneath your decking, we recommend including a 1% decline on your concrete base.

## 2 Laying Your Joist Network

Begin laying your joists directly onto your concrete base. The spacings (or centres) of your joists should be 250-350mm, and they should ideally run at right angles to the direction of your deck boards.

Ensure that your joists are orientated with the guidance channel facing upwards before attaching them to the concrete base (this will assist with screwing and water drainage).

A gap of approximately 8mm should be left between joins in joists, allowing for expansion. Double joisting is required where you expect deck boards to meet at butt-joints.

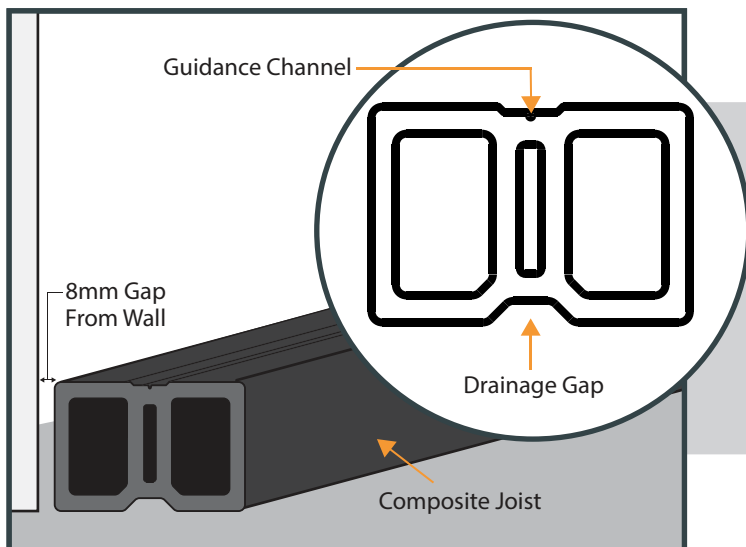
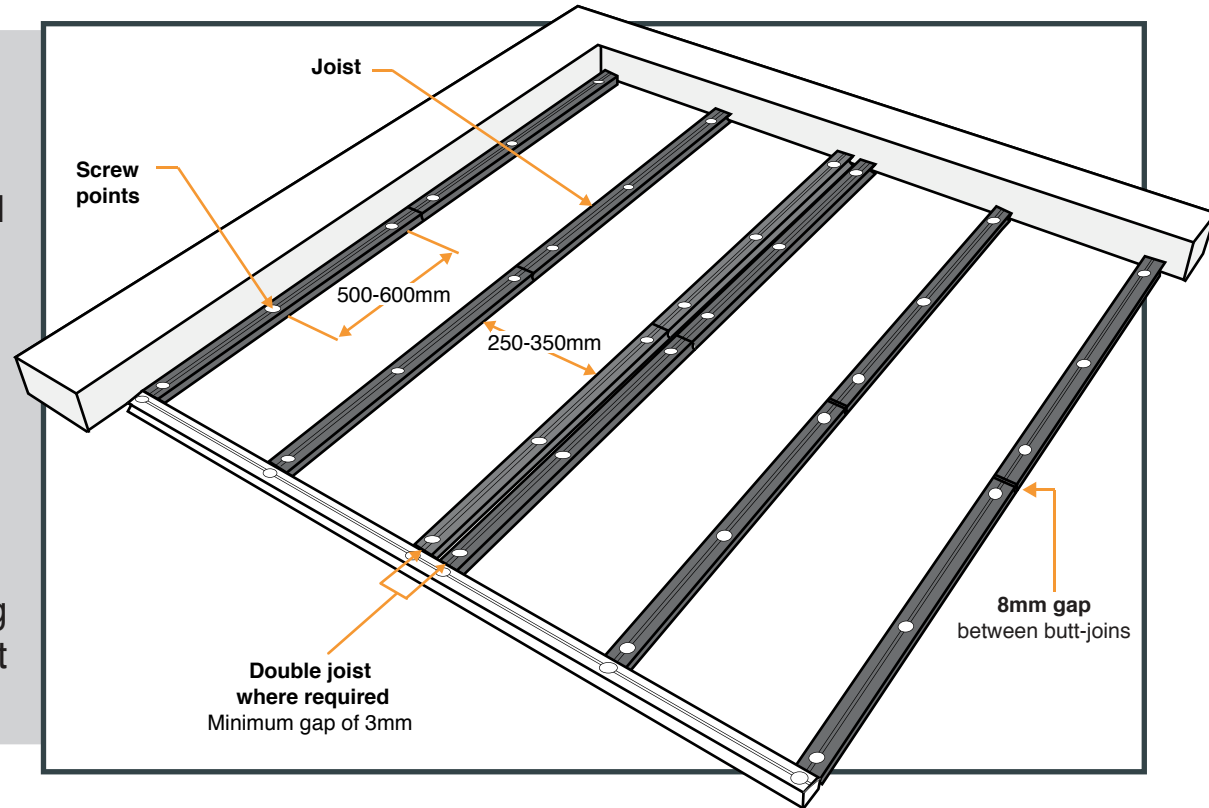

## 3 Attach The Joists To Your Concrete Base

Begin attaching the subframe by pre-drilling through the joist and into your concrete base. Your first fixing should be approximately 70mm from the edge of the joist. Continue to attach the joist at 500-600mm intervals using a 60mm screw.

A close-up photograph showing the installation of a decking subframe. Several parallel wooden joists are laid out on a dark, flat surface. Each joist is supported by a black adjustable pedestal with a green gear-like top. The pedestals are spaced evenly along the joists. In the upper right corner, a portion of a dark brown composite decking board is visible, showing its wood-grain texture.

NeoTimber<sup>®</sup>  
COMPOSITE DECKING

## INSTALLATION USING OUR ADJUSTABLE PEDESTALS

The NeoTimber Adjustable Pedestal solution can be used in conjunction with our Plastic Lumber in order to provide your decking subframe with height - ideal for installation on a flat, solid base, such as roof terraces, balconies and concrete areas.

# INSTALLATION ADJUSTABLE PEDESTALS

## Our Fully Adjustable Pedestal Range

Our selection of fully adjustable pedestals provide you with an easy-to-use system that elevates your subframe without the use of posts. We provide a selection of 5 pedestals, the adjustable heights of which can be seen in the table below.

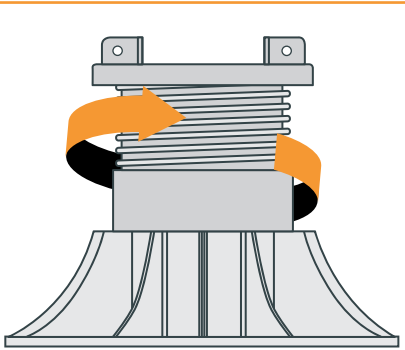
Pedestal Options	
18-30mm	 <p>Adjustable Height Pedestal</p>
30-60mm	
60-140mm	
140-220mm	
150-310mm	

When achieving the required height of your decking project you must factor in the adjustable height of the pedestal, the thickness of the chosen joist and the thickness of your chosen board.



### NeoTimber Advice

#### Using Adjustable Pedestals On A Roof Terrace

When fitting to a roof terrace, screwing into or interfering with a waterproof membrane should be avoided at all costs. The collective weight of the subframe and decking, means that there is no requirement to bolt the Adjustable Pedestals to a base.

# INSTALLATION ADJUSTABLE PEDESTALS

## 1 Laying Your Pedestals

Starting at the edge of the proposed area, begin by laying the pedestals in a linear fashion to form a grid layout.

For gridlines which will support the span of the joists (Gridline A), the spacing distance between pedestals are determined by the maximum support span of the joists used (see table below for reference).

Joist Type	Max Support Span
Small Plastic Joist	500mm
Large Plastic Joist	1500mm

For gridlines which will support the span of the deck boards (Gridline B), follow standard spacings at a distance of between 250-350mm.

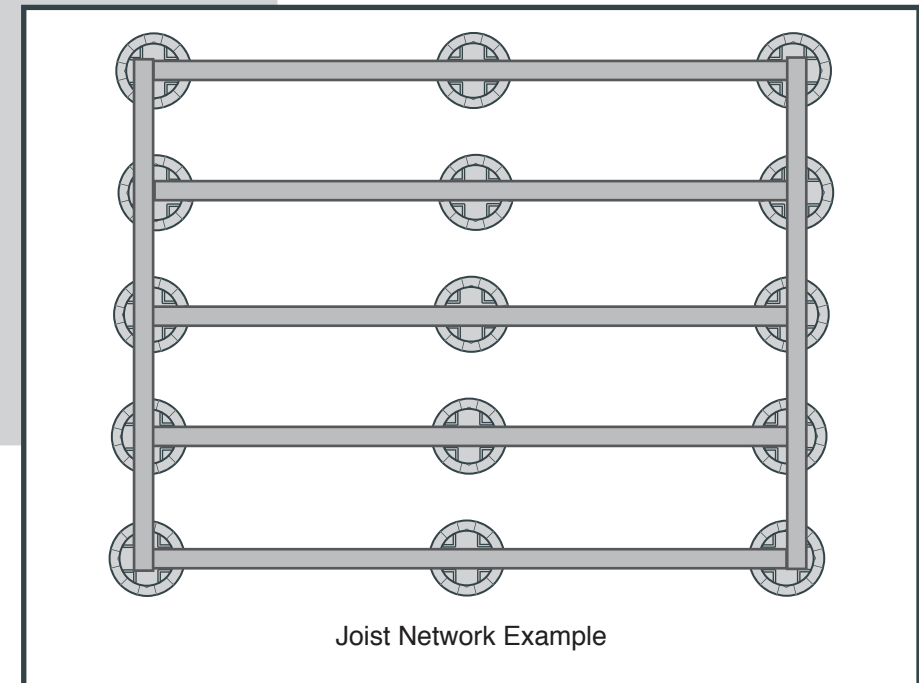
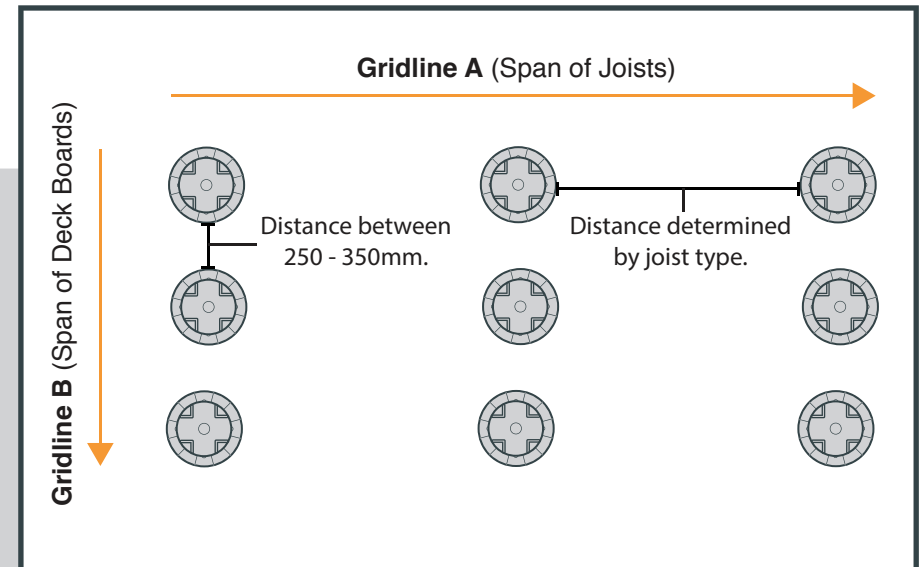

## 2 Lay Your Joists Onto Your Pedestals

Once your pedestal network is in place and correctly aligned, lay each joist on top of your pedestal network. The direction of your joists should be laid at right angles to the direction you wish to lay the boards.

If required, level the height of your joists by rotating the base of each pedestal. Ensure your joists sit level with the assistance of a spirit level.

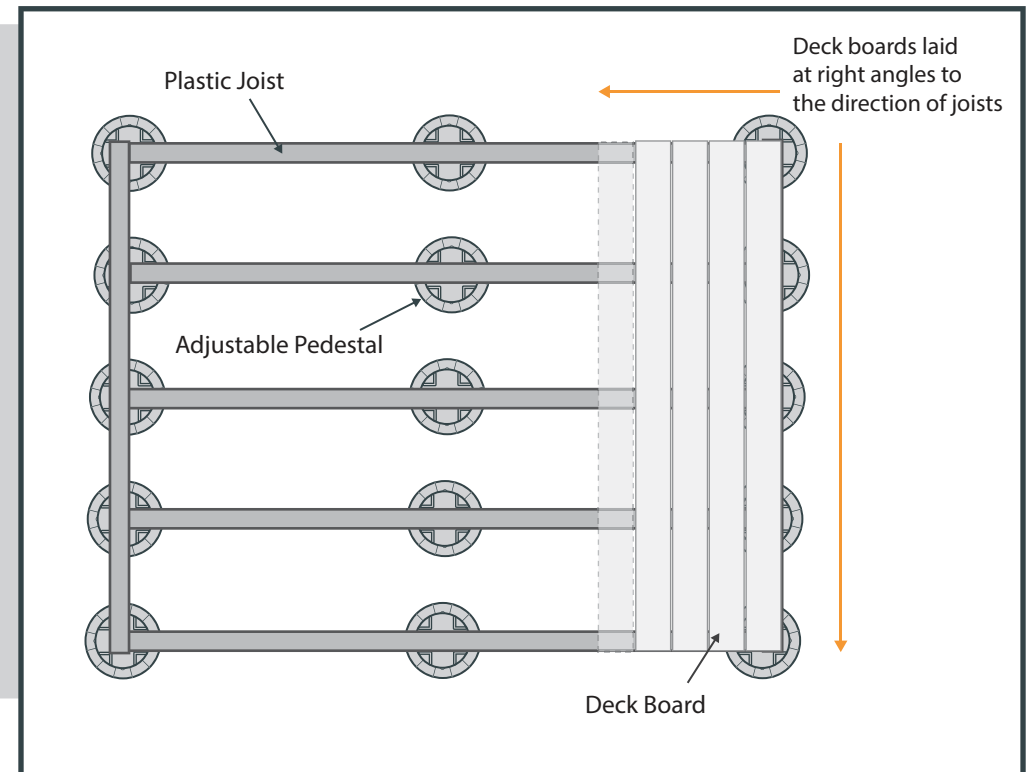
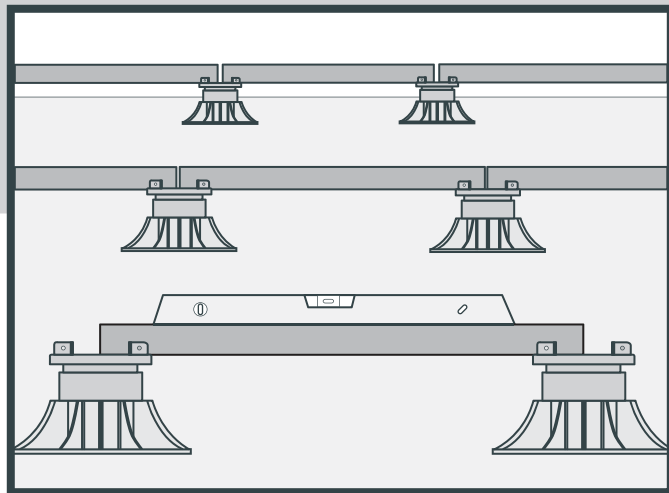

## 3 Fix The Joist Network To The Pedestals

When your joists are firmly in place, secure them into the pedestal by screwing through the joist cradle and into the side of the joist.

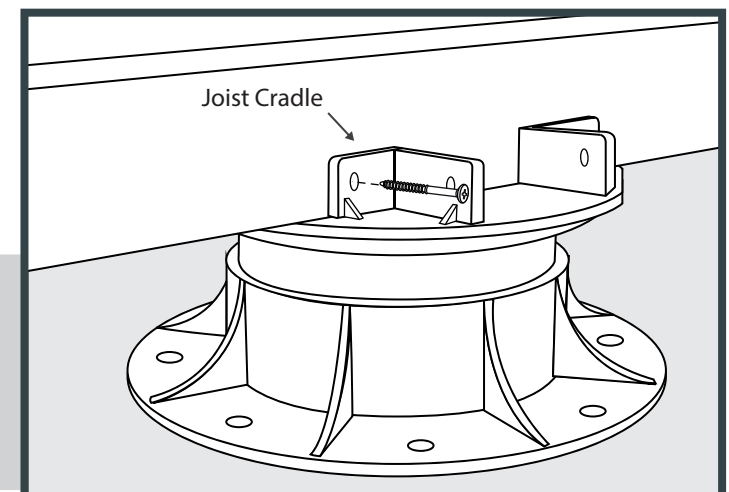

## 4 Securing Joists At Joins

Butt-joints must be supported by a pedestal and an expansion gap of 20mm should be left between two joining joists. The use of a 250mm length of plastic joist can be used as a cross member for additional structural support.

Ensure that joins in the boards are supported by the use of double joists.

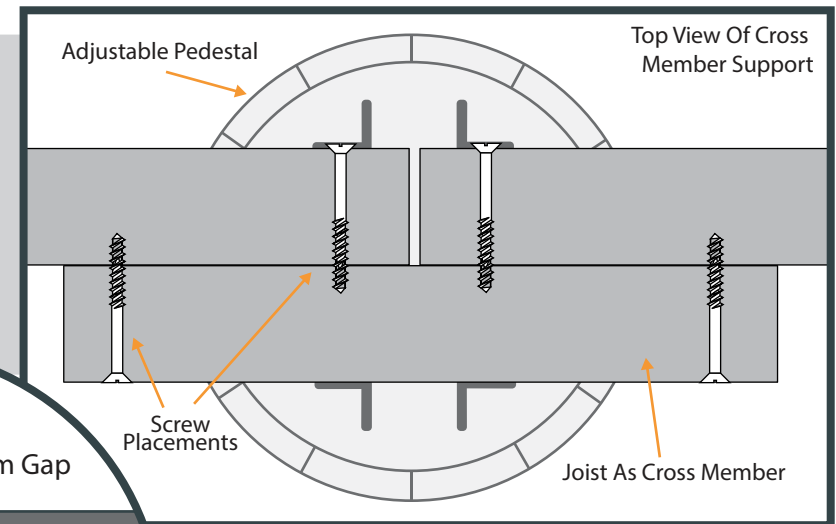
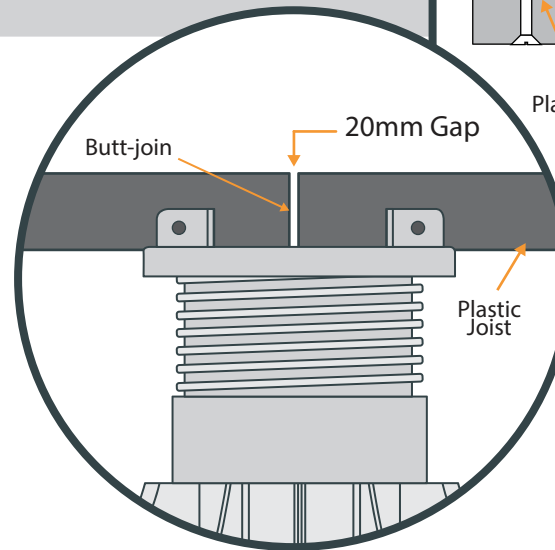

## 5 Laying Boards Onto Your Subframe

Once your subframe is securely in place, lay your boards over your joist network, following the same principles as outlined in pages 24-27 of the Installation Guide. Begin with the first row of boards and work your way down the proposed area using both our Starter Clips and FastClips to securely attach the boards to the joists.



**NeoTimber**<sup>®</sup>  
COMPOSITE DECKING

## INSTALLATION USING OUR PLASTIC JOISTS AND POSTS

NeoTimber Plastic Joists and Posts offer a long-life decking framework solution that is designed as a like-for-like alternative to a traditional timber subframe. This section outlines a three phase guide on how these products should be installed.

# INSTALLATION PLASTIC JOISTS AND POSTS



## Our Plastic Joists And Posts

For installation of decking subframes on uneven, soft ground, NeoTimber recommend the use of Plastic Lumber.

Consisting of a Plastic Joist and Post product, this solution represents a long-life, moisture resistant solution formed entirely from recycled material.

The installation of our Plastic Joist and Post product follows a three-phase process, as shown below:

### Phase 1

#### Install A Plastic Post Network

The NeoTimber Plastic Post system is fixed to a base and elevates the subframe, providing the deck area with a solid framework for which a consistent height can be achieved.

### Phase 2

#### Attach A Bearer Network

Installing the NeoTimber Large Plastic Joist as a supporting bearer will provide the project with additional structural support.

### Phase 3

#### Fix A Joist Network

The NeoTimber Large Plastic Joist is then laid to form a network for which the NeoTimber decking boards are laid upon. Added noggins can be used for additional structural support.

## 1 Lay Your Post Network And Secure Into Place

Once your area is clearly outlined, mark a grid-layout and evenly lay your post network. Space the posts at 1,500mm intervals in residential settings and 1,000mm in commercial settings. This is in-keeping with the maximum support span of the Large Plastic Joist that will be used to form your cross-bearer and joist network.

Fix the posts to your base by forming a hole and cementing them into the ground. A third of the length of the post (or at least 500mm) should be secured under the surface of your base. Ensure the posts remain in an upright position as the concrete sets and that the tops of the posts are level with one another.

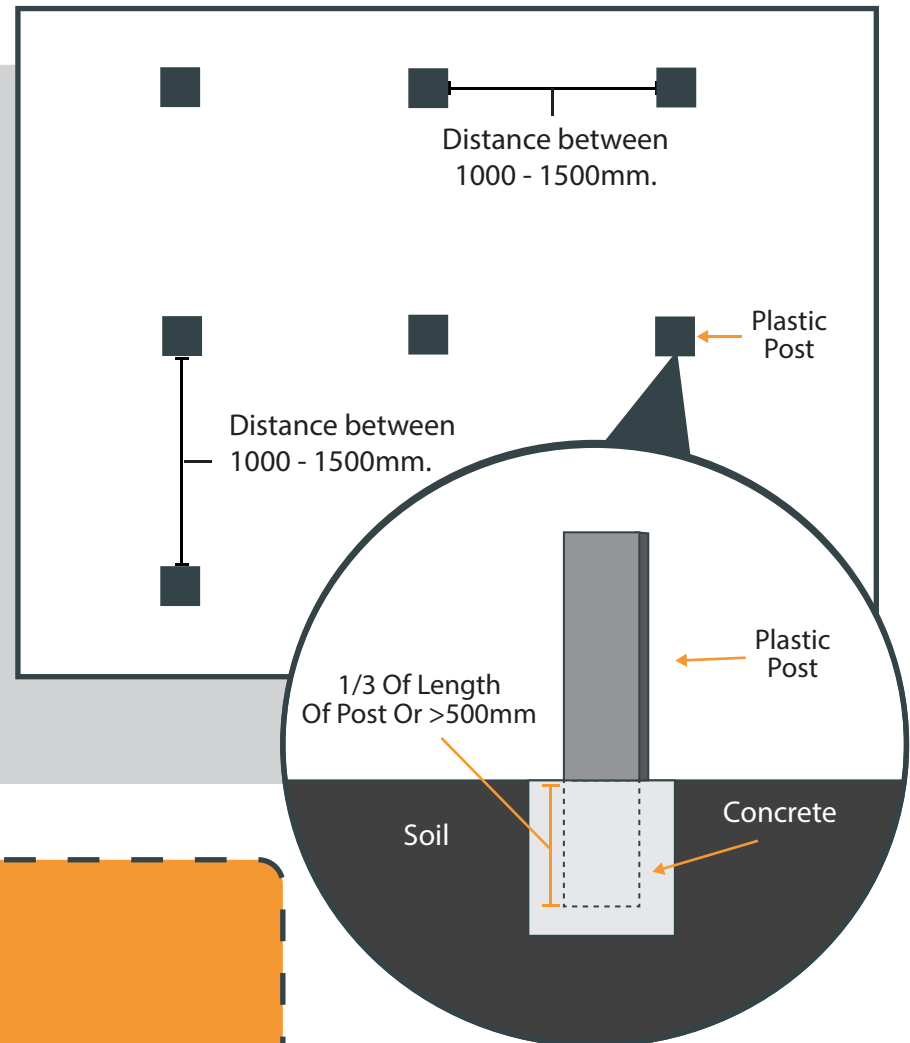

### NeoTimber Advice

#### Preparing Your Base

We recommend clearing all vegetation from below your decking area prior to install, especially on low-lying projects. Laying a weed control mat once your post network is laid reduces the promotion of plant and weed growth beneath your framework.

This can be held in place either by a layer of gravel or with fixing pegs.

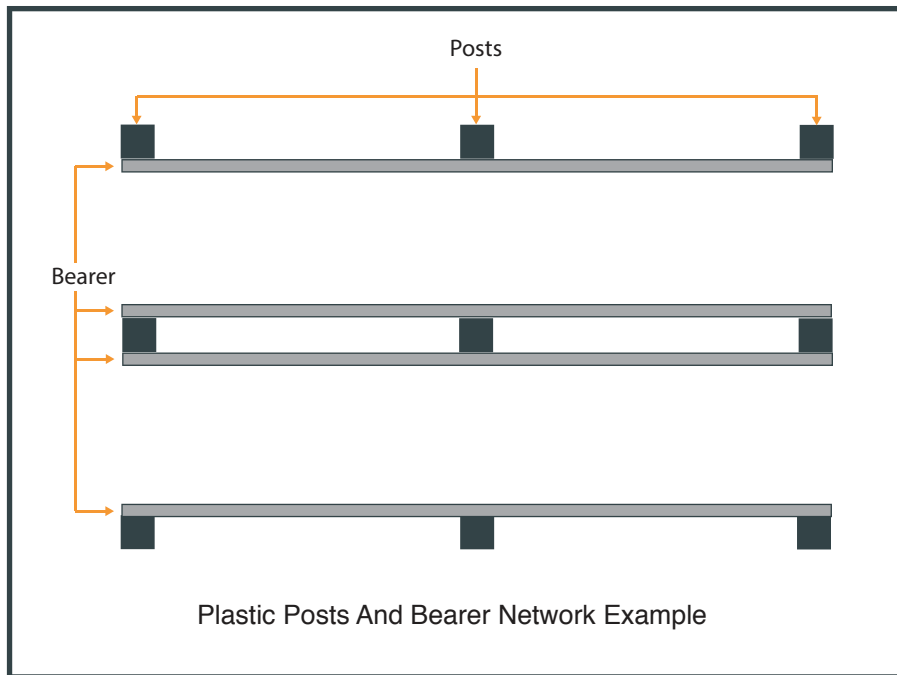

## 2 Laying Plastic Joists To Form A Bearer Network

Form a network of cross-bearers along the length of posts with the NeoTimber Large Plastic Joist, providing a base of structural support for your joist network. When fixing the bearers to the posts, a gap of 125mm should be left above the bearer in order to accommodate for the thickness of the joist.

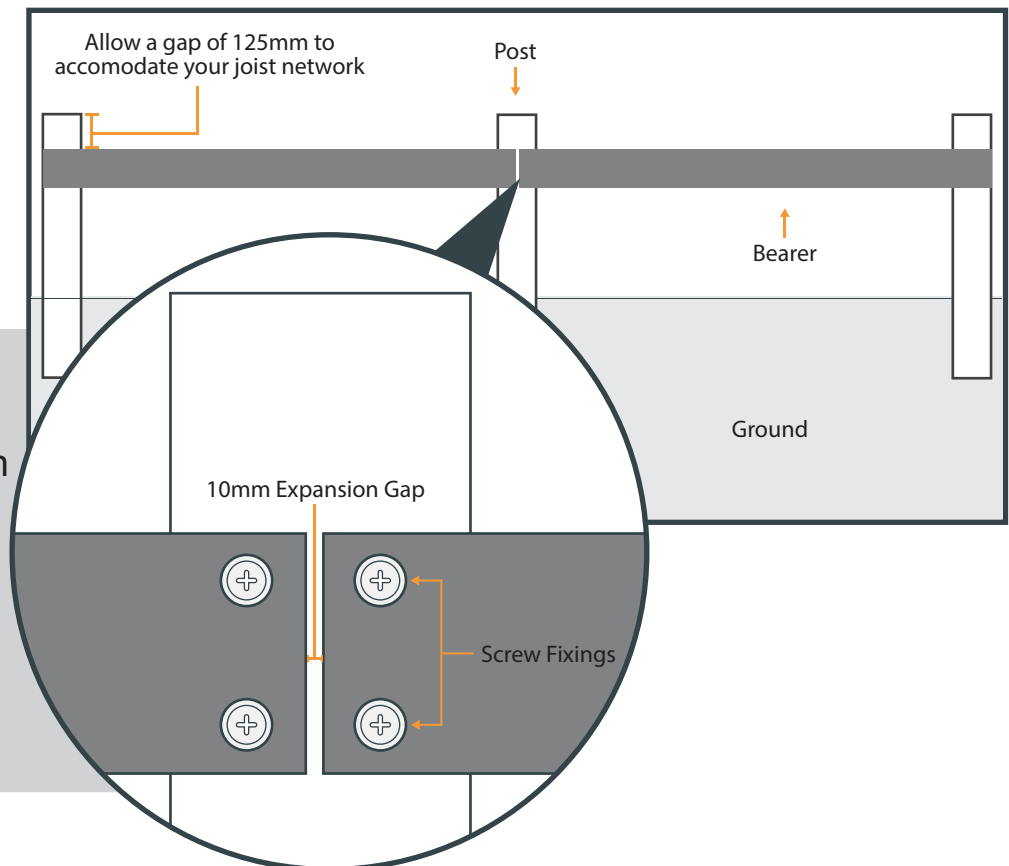

## 3 Securing Bearers At Joins

Joining bearers must be supported by a post and an expansion gap of 10mm must be observed. Ensure that joins in joists are supported by double bearers.

Use 2 x 6-10mm single thread screws at every intersection between a bearer and post to fix securely. Pre-drill the material with an oversized pilot hole (approximately 3mm).

## 4 Laying Your Joist Network

Joists should be laid directly onto your bearer network in accordance with the recommended spacings of 250-350mm. Begin by installing the outside joists to the subframe and continue fixing along the decking bearer network.

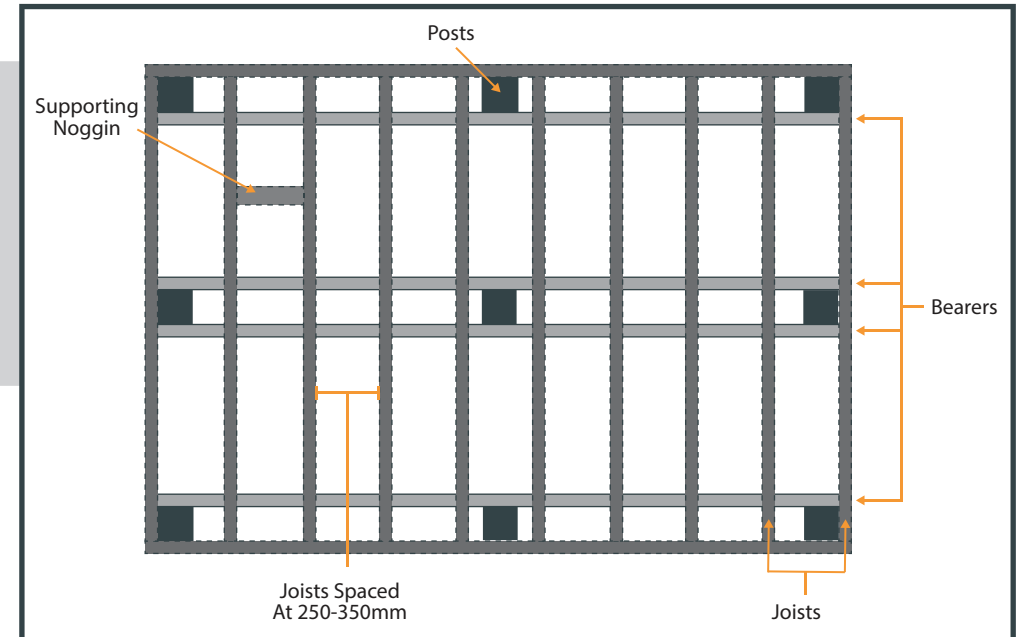
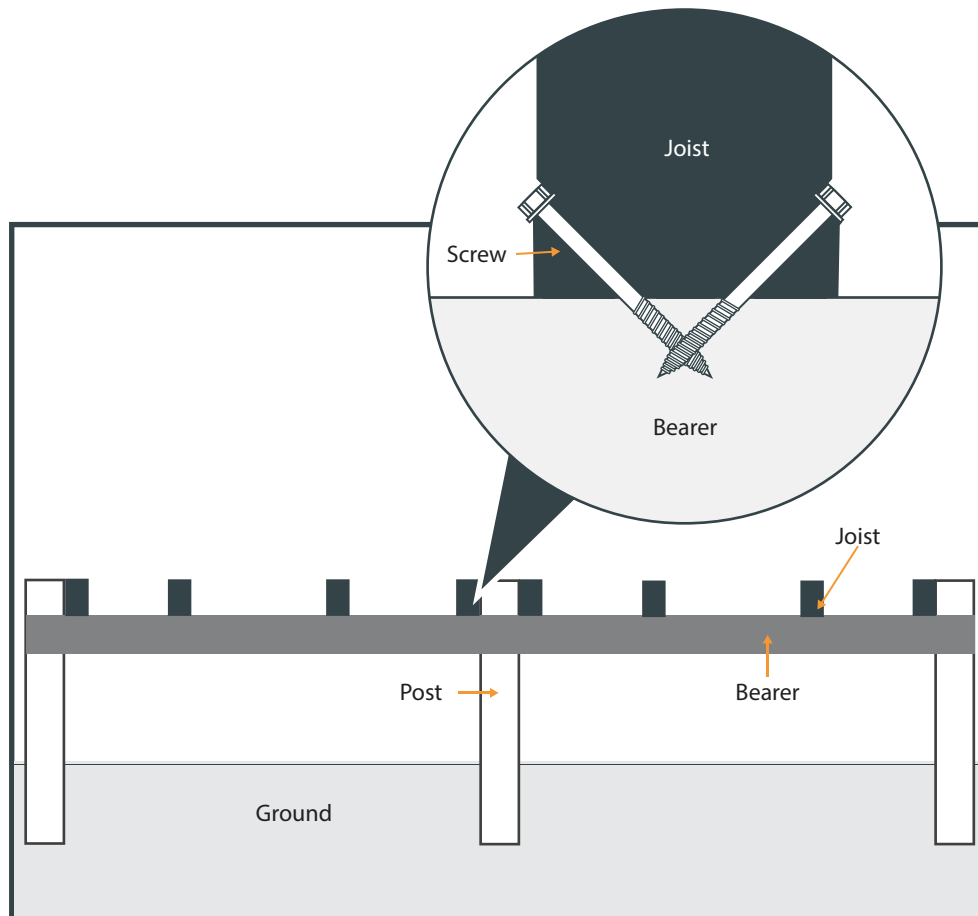

## 5 Fixing Your Joists

Fix by screwing diagonally through the joist into the bearer. Use a 6-10mm single thread screw to ensure proper fixing and pre-drill the material with an oversized pilot hole (approximately 3mm).

Off-cuts of the Plastic Joist can be used to form a series of noggins along the length of your joists to offer additional support. When joining two joists, ensure an expansion gap of 10mm is left.

Where two boards are expected to meet, ensure sufficient support is provided in the form of a double joist.



**NeoTimber**<sup>®</sup>  
COMPOSITE DECKING

## INSTALLATION **DECK BOARDS AND TRIMS**

Our hidden Starter and FastClip system allows for easy, convenient installation of your NeoTimber deck boards, while our trims provide the finishing touches to the exposed edges of your project. This section will provide a step-by-step guide on how to install our boards and trims, regardless of the subframe option you opt for.

# INSTALLATION DECK BOARDS AND TRIMS

## 1 Install The First Board Using Starter Clips

Once your subframe is in place and your joists are laid at 250-350mm spacings, you are set to begin installing your deck boards. Starting at the outside edge of the decking project, begin attaching Starter Clips to the edge of your framework using the steel screws provided. We recommend counter-sinking to assist with insertion of the screws.

Position a Starter Clip at the intersection of each joist to ensure a secure fixing.

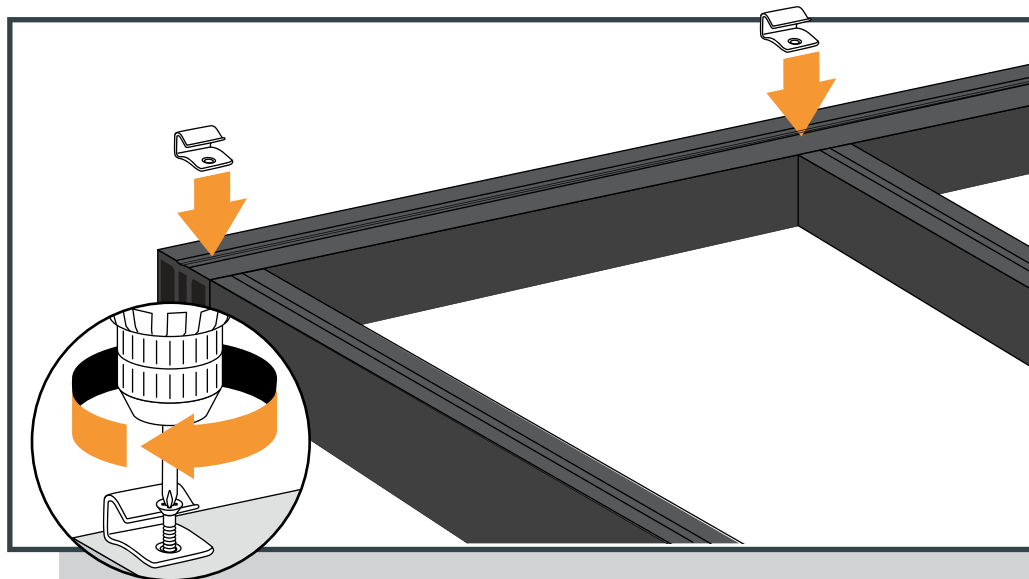
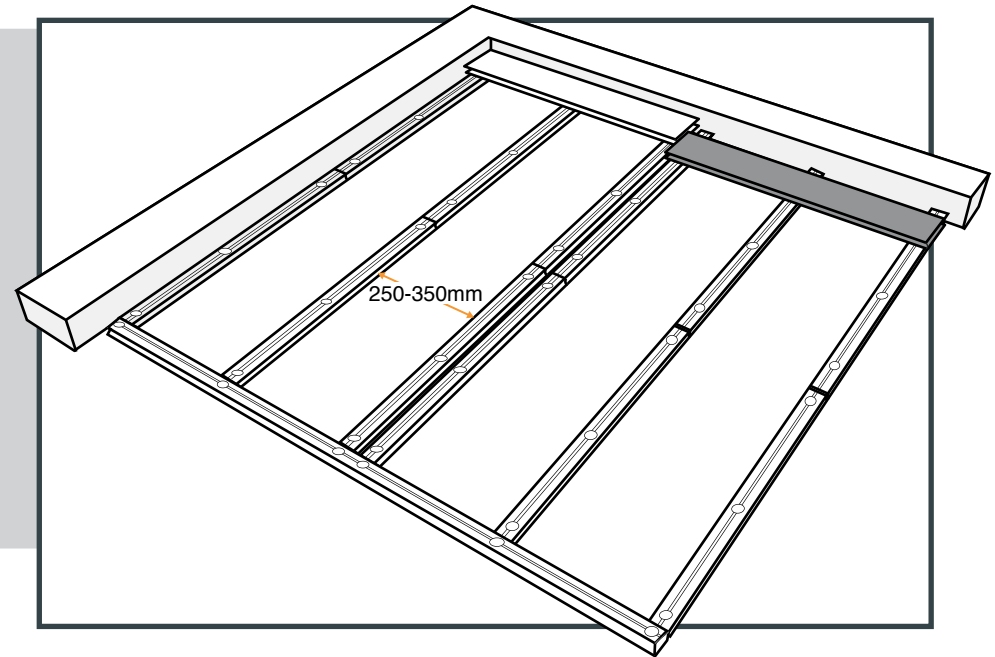

When all Starter Clips are securely positioned, align the grooved-channel of our deck boards with the opening on the Starter Clip and position securely.

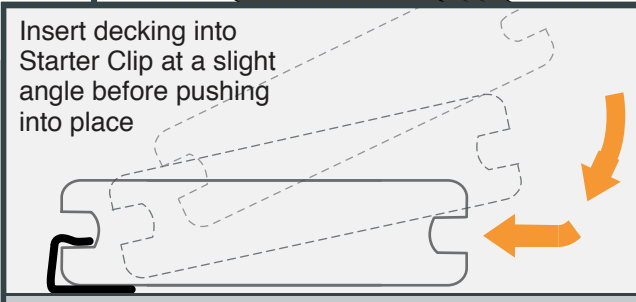
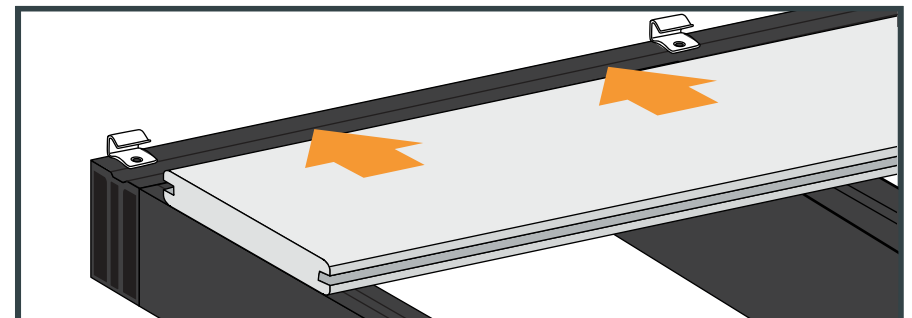

# INSTALLATION DECK BOARDS AND TRIMS

## 2 Install All Subsequent Boards Using Metal FastClips

Once your first row of deck boards are in place, use our 3mm Metal FastClips to fix all subsequent boards to the subframe.

Place the singled pronged side of the Metal FastClip into the exposed grooved-channel of the first board. Using one screw, secure the clip into place by screwing through the counter-sunk hole. Attach a clip at every intersection between a board and a joist.

Line-up your second row of boards and align the grooved-channel with the opening of the clip and click into place.

Repeat this process to fix subsequent boards along the decking area.

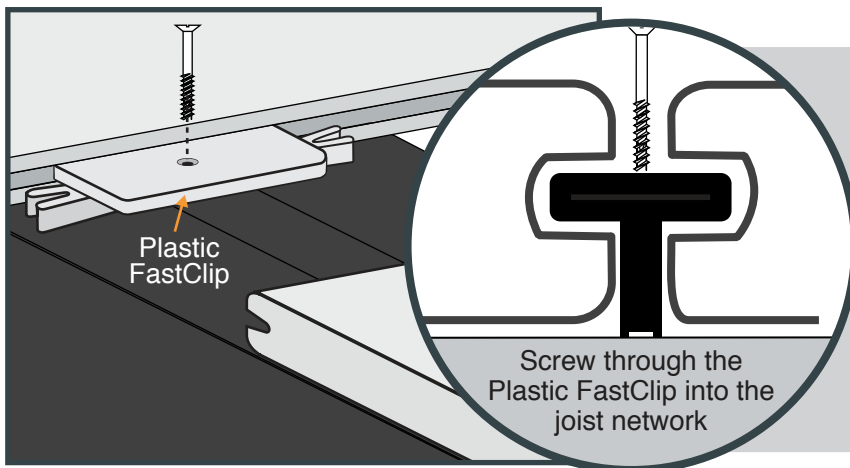
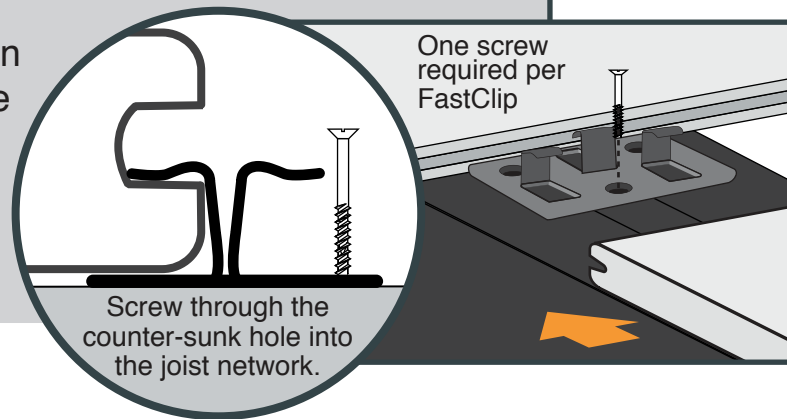
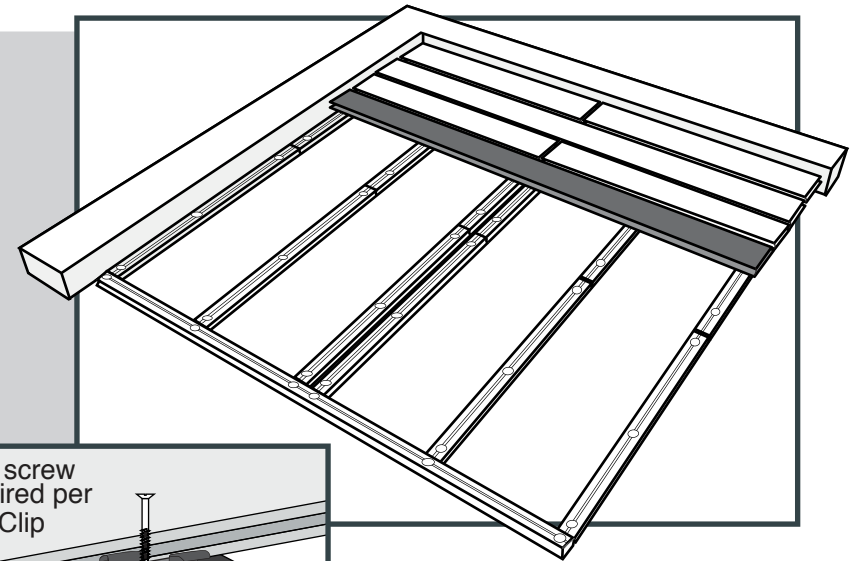

## Alternative Fixing Using Plastic FastClips

6mm Plastic FastClips can be used as an alternative to our Metal FastClips. Aside from having a different fixing method, the same principles should be followed when installing either clip. The benefit of using our Plastic FastClip is that it allows you to access any board along the length of a project without the need to remove the previous run of boards.

## 3 Attach The Final Board

Place the grooved-channel on the inside of the final board into the last row of FastClips. Once secured, pre-drill an oversized pilot hole at a 45° angle (when possible) into the grooved-channel on the exposed edge, as per illustrations below. Screw into the joist at 300mm intervals to securely fix the board to the subframe.

We recommend the use of NeoTimber Coloured Decking Screws for a secure and discreet fixing.

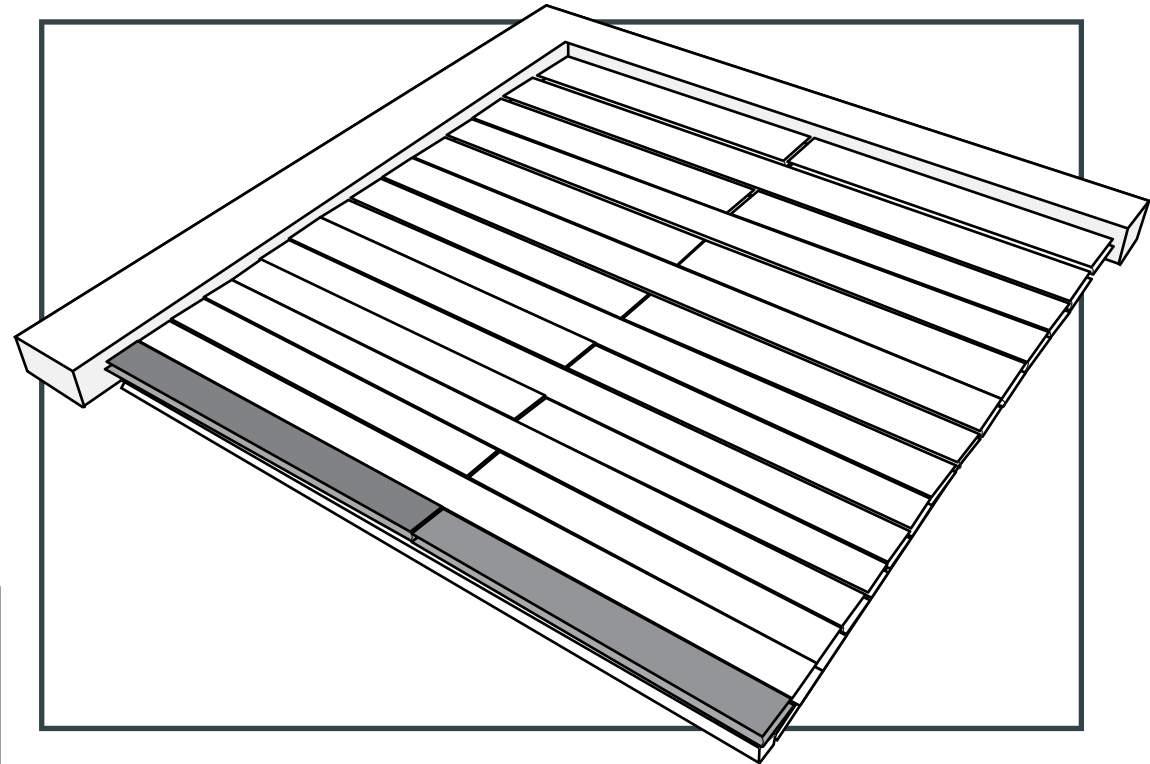
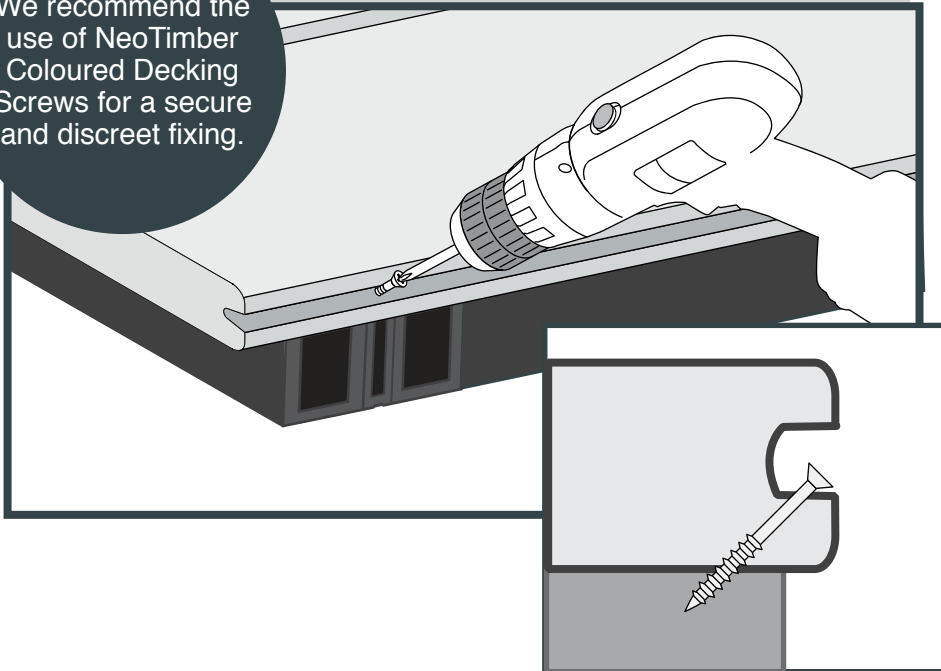

### NeoTimber Advice

#### Alternative Fixing Method

When the grooved-channel is not fully accessible, screw directly through the top of the board into the joist network. Pre-drill an oversized pilot hole to avoid cracking the deck board

## 4 Apply Finishing Touches

Edges of the deck boards can be finished with either a Skirting Trim, Corner Trim or a combination of both.

Both the Corner and Skirting Trims can be screwed directly into joists or deck boards. It is advised that before doing so, an oversized pilot hole is drilled into the trim to ensure that it does not split or crack when screwed. We recommend the NeoTimber Coloured Trim Screw for a discreet finish.

When joining one trim to another, a minimum gap of 2mm should be left between trim ends allowing for expansion.

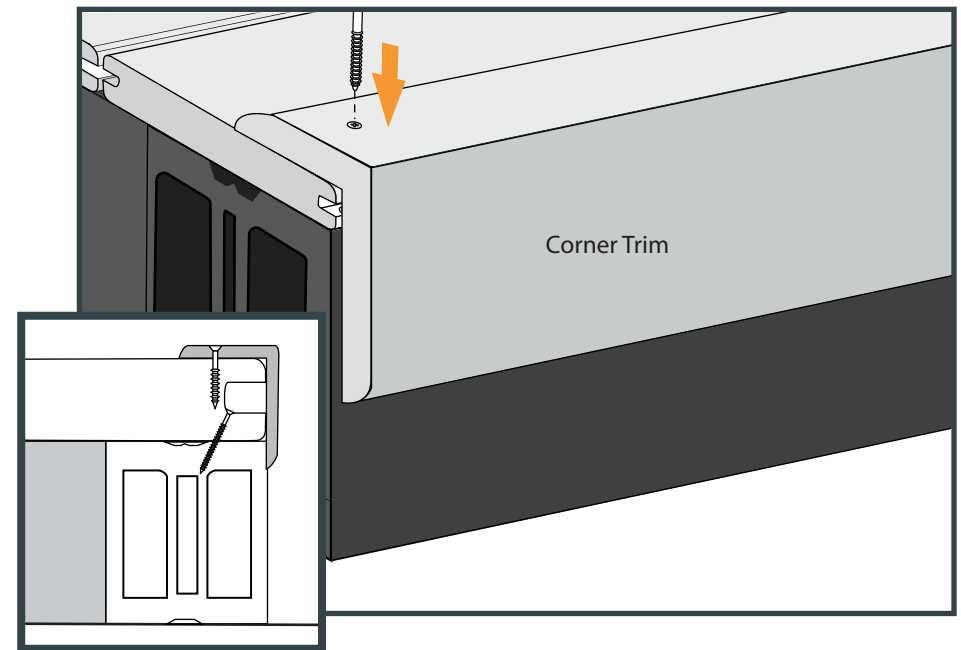
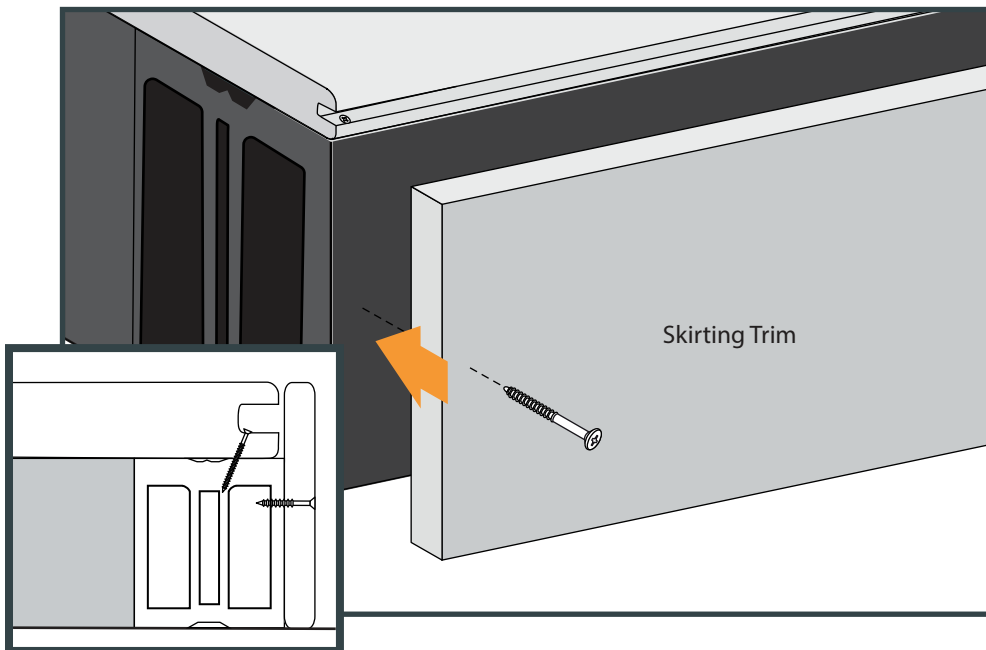
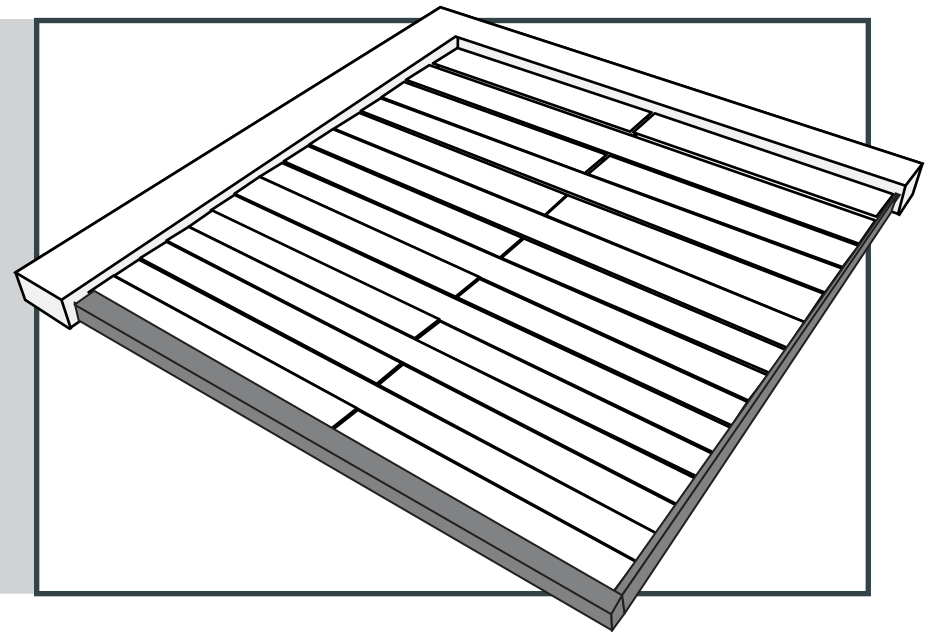



## INSTALLATION DESIGN CONSIDERATIONS

Additional design considerations often need to be taken into account when completing a decking project. This section will cover guidance on picture-framing, whereby instructions on how to install the NeoTimber Edge Board are included; this is followed by a how-to on incorporating decking steps into your project.

## Picture Framing And Subframe Considerations

A picture frame design involves forming a border around the perimeter of a decking project. Consideration of this design should be taken when forming your subframe, as it is important to install double joists in areas of the project where boards will run perpendicular to the main run of decking.

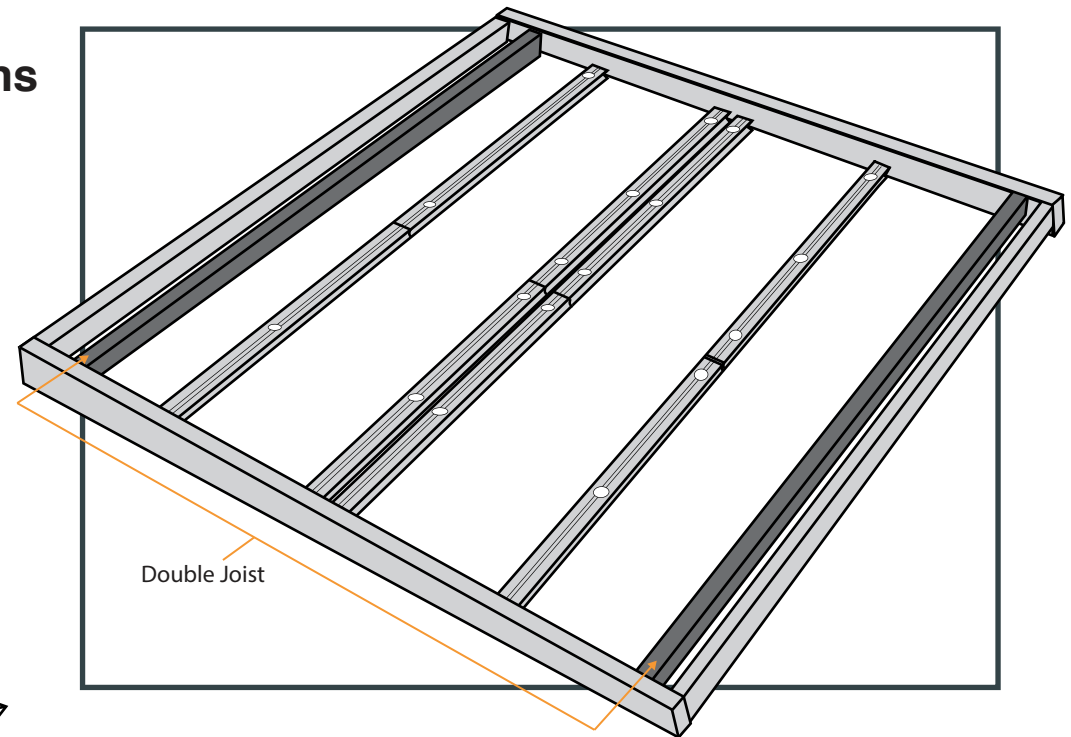
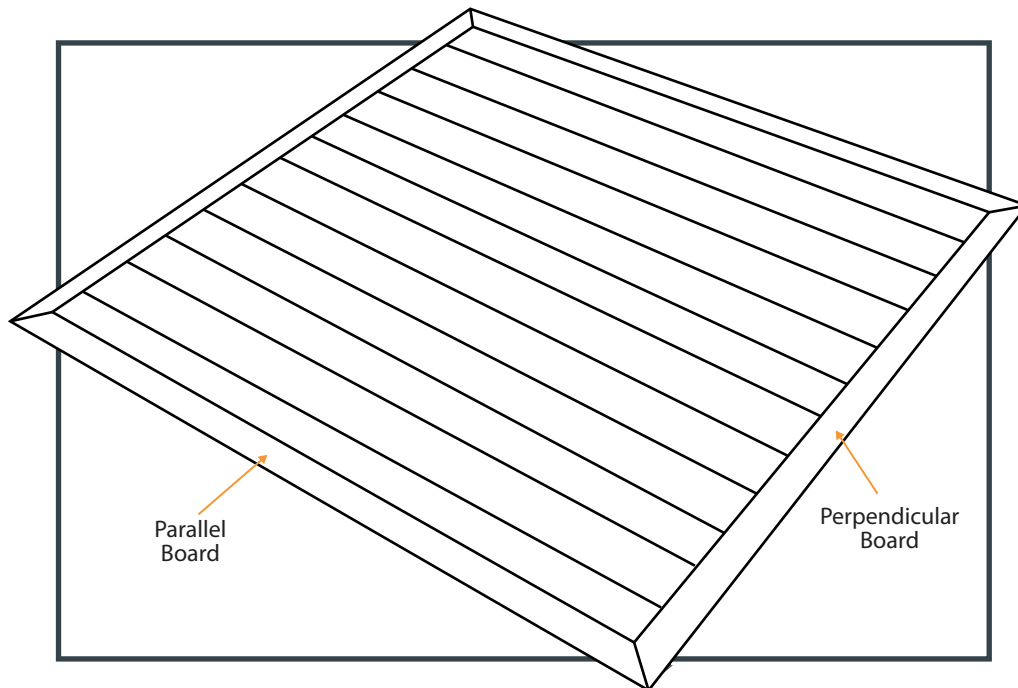

## Frame Options And Laying Considerations

This guide provides installation methodology for two different types of picture framing options. One option involves utilising the NeoTimber deck board, the other involves the use of the NeoTimber Edge Board.

Regardless of which option you choose, a picture frame design involves two different types of installation method: installation of the perpendicular board and the installation of the parallel board.

## Option 1: Deck Boards As A Picture-Frame

The method for laying parallel and perpendicular deck boards differ from one another and consideration of both is outlined below.

### 1 Installing The Parallel Frame Board

Boards that run parallel to the main run of boards can be installed following standard installation methods, outlined in pages 24-26. Where boards meet at corners of the picture frame, a 45-degree mitered edge should be made and an expansion gap of 4mm must be observed.

### 2 Installing The Perpendicular Frame Board

Boards that run perpendicular to the main decking area must be laid on a run of double joists. For fixing this board, you must install a Starter Clip on the inside joist. Once the inside of the board is securely fastened, screw the exposed grooved edge into the subframe.

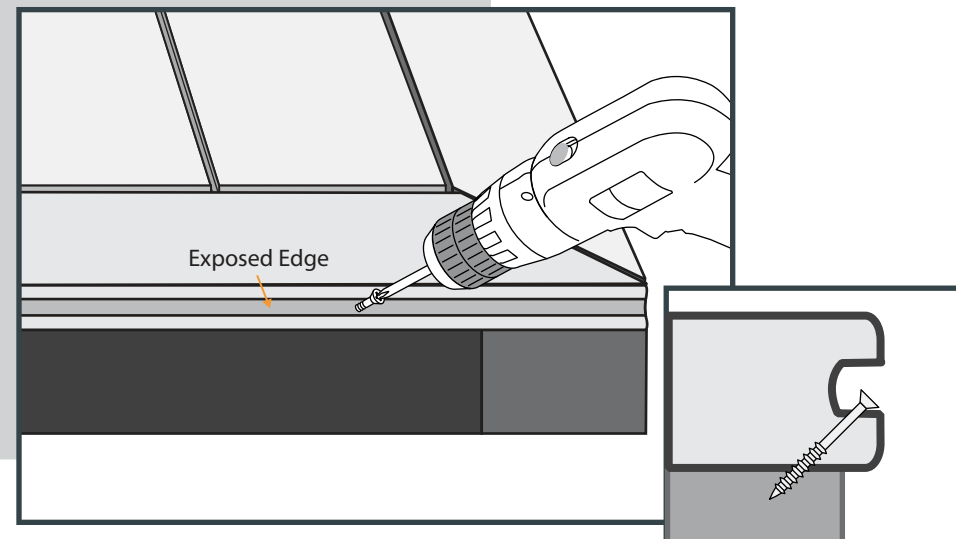
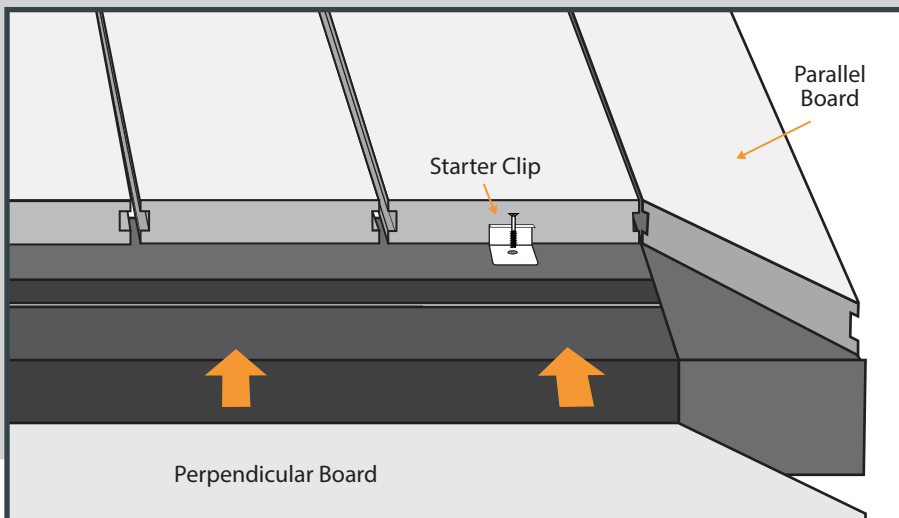
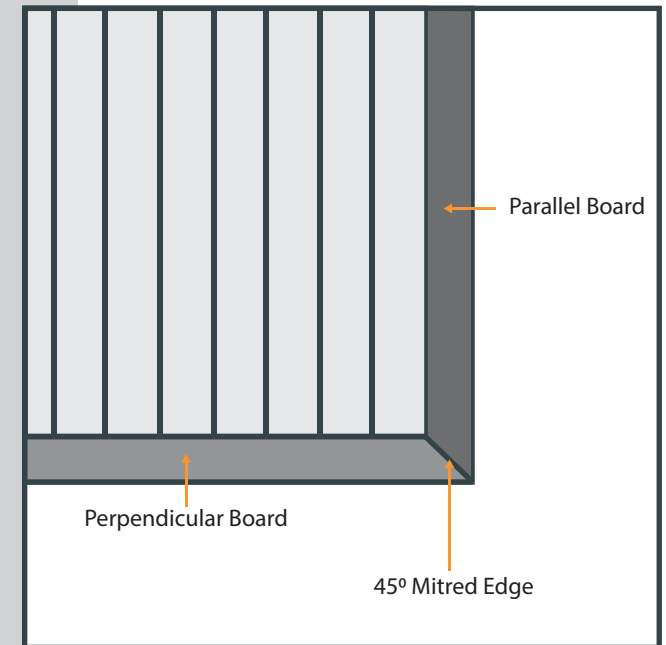

# DESIGN CONSIDERATIONS **PICTURE FRAMING**

## Option 2: Edge Boards As A Picture Frame

NeoTimber Edge Boards that form the picture frame of your project must be laid before installing the main run of decking. This allows the picture frame to be correctly fixed on all sides.

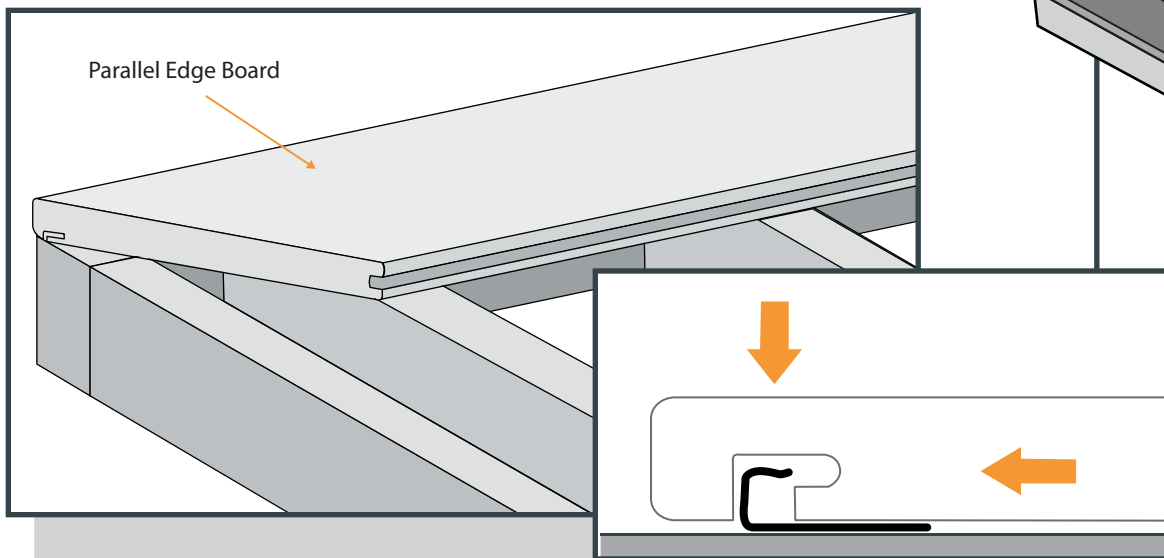
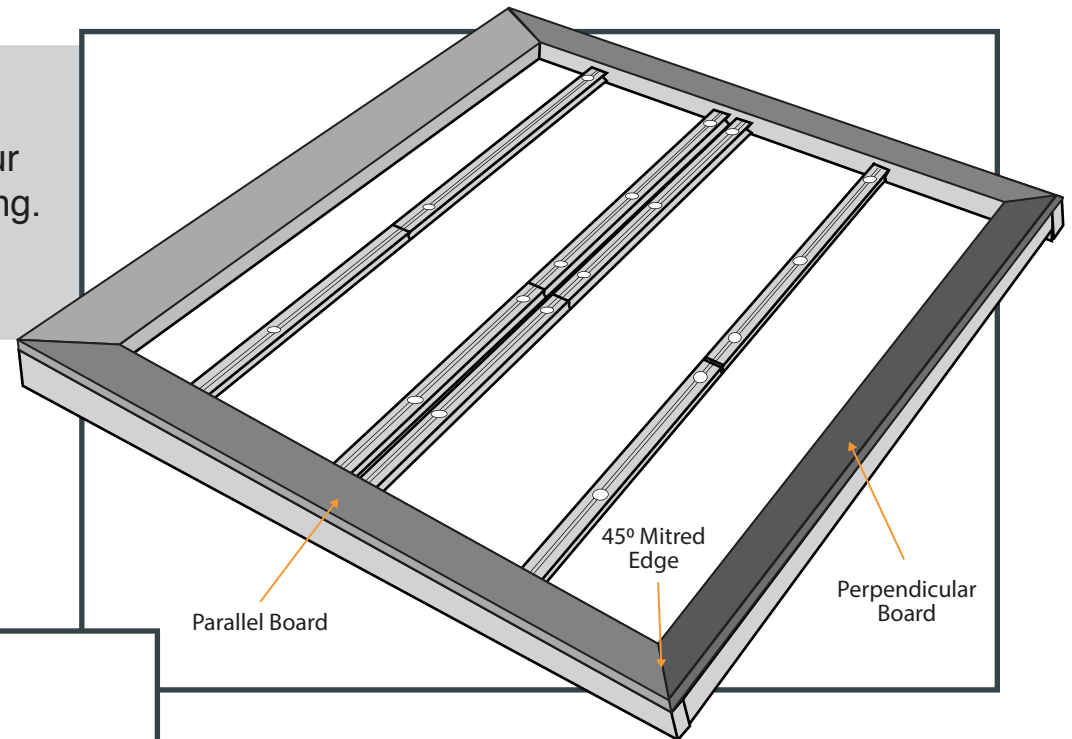

### 1 Installing The Parallel Edge Board

Install a Starter Clip on the outside edge of your joist framework and fix to the opening on the underside of the Edge Board, securely fastening into place. Once your Edge Board is securely positioned, install a FastClip to the exposed grooved-edge on the inside of the Edge Board, ready for laying all subsequent deck boards. Where boards meet at corners of the picture frame, a 45-degree mitered edge should be made and an expansion gap of 4mm must be observed.

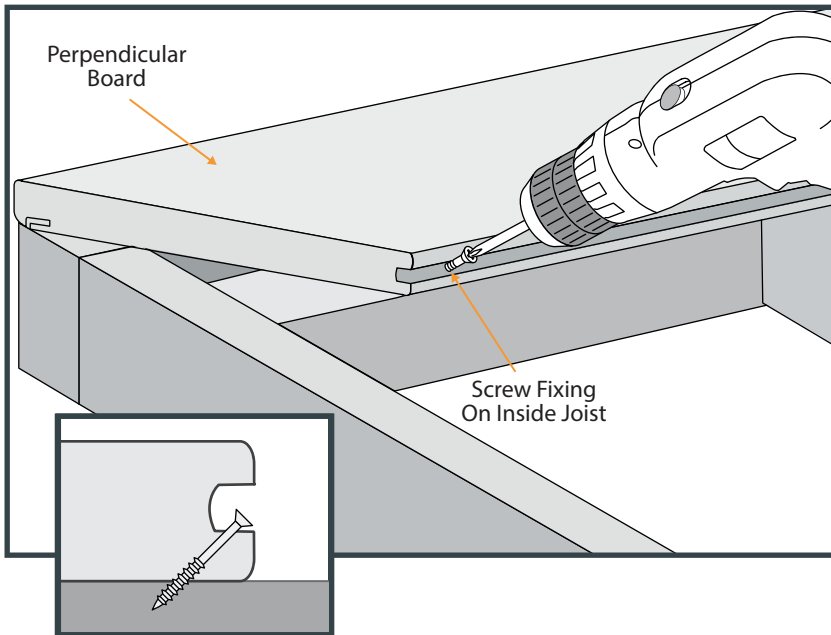

## 2 Installing The Perpendicular Edge Board

Fix the outside edge of the perpendicular Edge Board by securing the underside with a Starter Clip, as outlined in Step 1. Then attach the inside of the Edge Board to your joist network by screwing into the exposed grooved-edge at a 45 degree angle. Join at 350mm intervals along the board and insert an over-sized pilot hole prior to screwing.

## 3 Installing Subsequent Boards

Once the Edge Board perimeter is securely fastened, install the main run of deck boards in a uniform fashion. Follow the steps outlined in page 25 of our installation guide for advice on using our FastClips to fix boards to your subframe.

Install the final board(s) of the decking run by face-fixing it to your joist network. Pre-drill the boards before screwing to avoid cracking them. Fix at every intersection between a board and joist. For a discrete and secure fixing, we recommend NeoTimber Coloured Decking Screws.

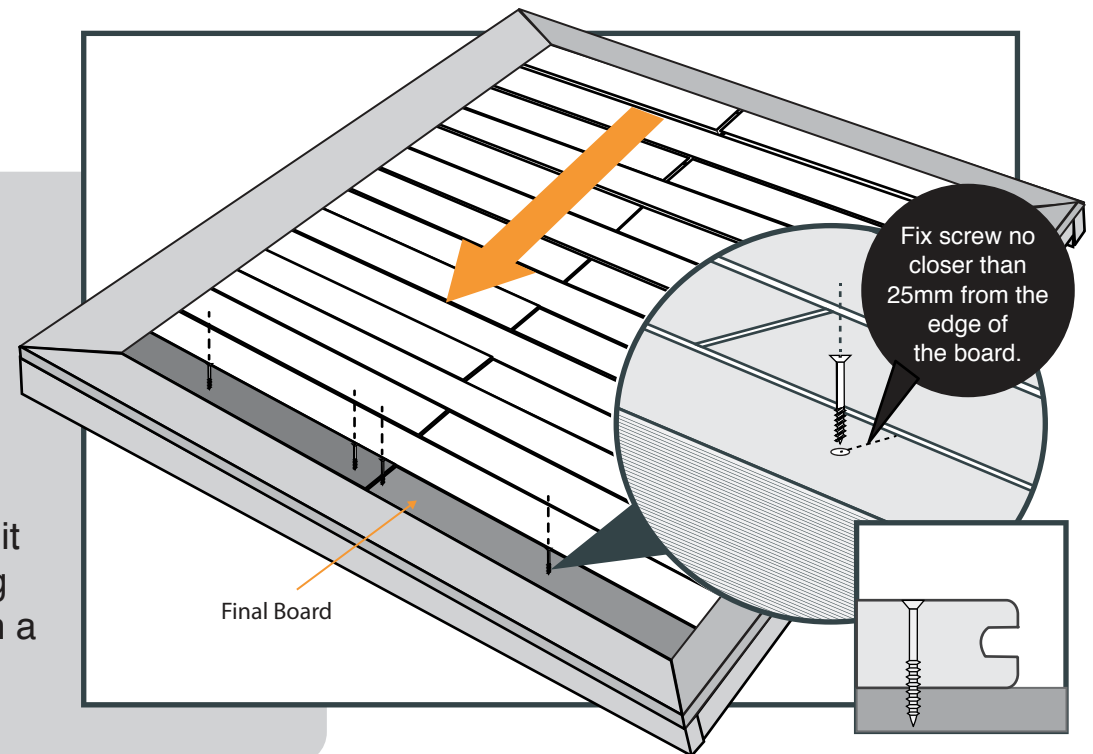

# DESIGN CONSIDERATIONS **DECKING STEPS**

## Step Framework Options

Decking steps should be carefully planned to ensure the rise and tread remain consistent along the run: the rise of the step should not exceed 190mm; the tread of the step must be between 250-450mm deep.

A flat, solid landing pad formed of concrete or gravel is recommended to provide a sufficient level of structural support below your step area.

There are two main methods you can employ to install steps to your decking project: Stringer and Box-Framed Steps.

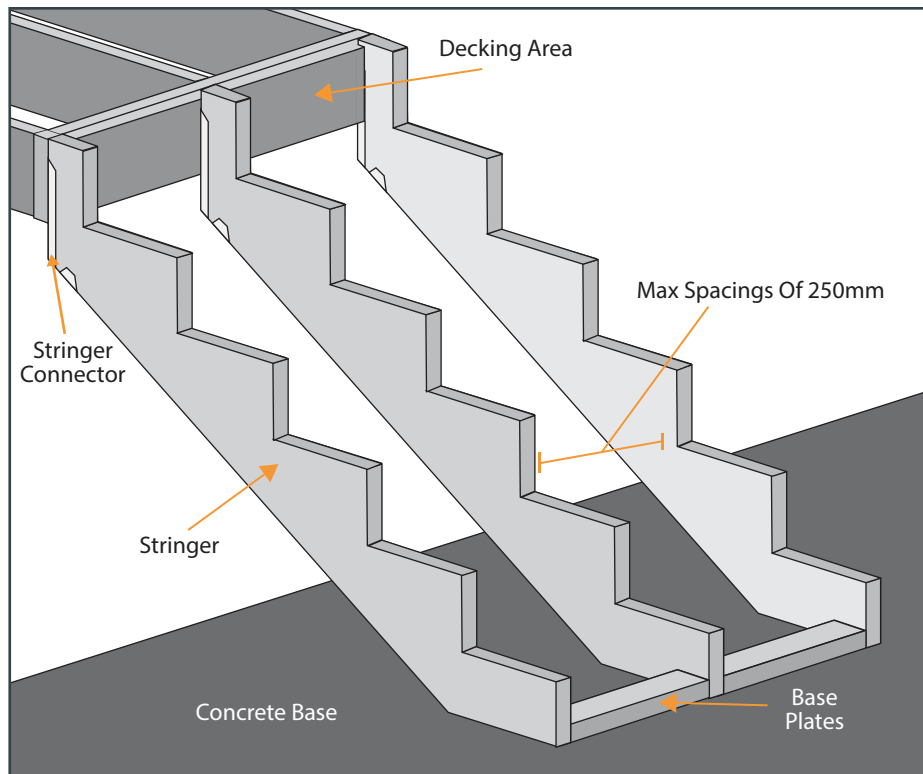

## Stringer Steps

Most commonly constructed from timber, a stringer is a support that spans from a decking subframe to the base of the step area. A network of stringers form the framework of a step.

- Notches should be formed in pressure treated timber and a carpentry square and a saw should be used to form the rise and tread
- To fix the stringer steps at the base of the steps, anchor the steps with a base plate and attach to the landing pad
- To fix the stringer steps to your deck area, reinforce the area of the subframe behind the steps with a stair header and install a stringer connector

## Box-Framed Steps

Box-framed steps are a series of boxes that are stacked on top of one another to form a run of steps.

- Form a box framework and infill with joists at 250mm spacings.
- Box-framed steps can be formed from timber, metal or NeoTimber Large Plastic Joists.
- Secure the box-frame to the decking subframe at every intersection using appropriate fixings.

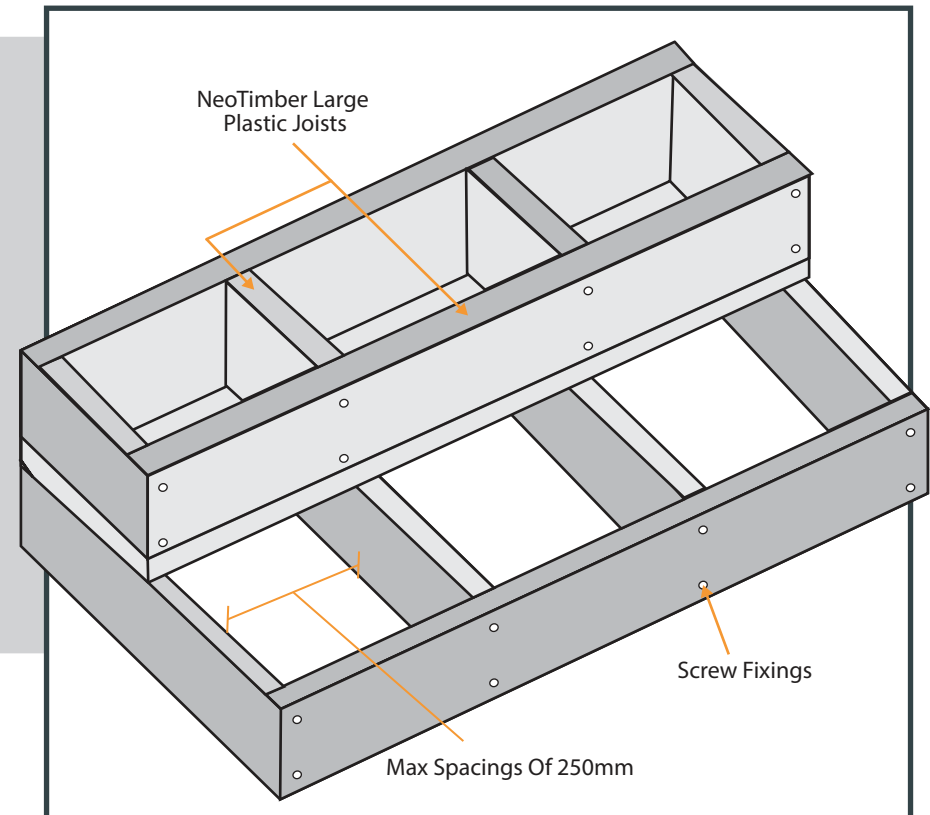

### When Forming The Box-Framed Steps With NeoTimber Large Plastic Joists:

- 1 Attach the joist to the frame with two screws at each end of the box-frame.
- 2 Pre-drill the material with an oversized pilot hole of approximately 3mm.
- 3 NeoTimber Plastic Posts can be fixed to the inside edge of the box-framed steps to provide additional structural support.

## Step Fixing Options

NeoTimber products can be used in a variety of ways to cover both the rise and tread of a step area. There is no “one-size-fits-all” solution when it comes to using our boards and trim products for step areas and the chosen finish often comes down to personal preference. The following provides installation advice on a variety of fixing options you have available to you - all of which offer a discrete finish for your decking step area.

### 1 Using NeoTimber Edge Board

Securely fix the Edge Board to the tread of your step by following Step 1 on page 31 of the installation guide.

#### Option A: Fix with NeoTimber Metal FastClip

When fixing the Edge Board with the Metal FastClip, the inside deck board on the step tread must be face fixed to be secured.

#### Option B: Fix with NeoTimber Plastic FastClip

When fixing the Edge Board with the Plastic FastClip, boards can be fastened to the subframe without the need to face fix the end board - a clip can be installed inbetween the boards and screwed when the boards are in-situ.

Option A: Metal FastClip Installation

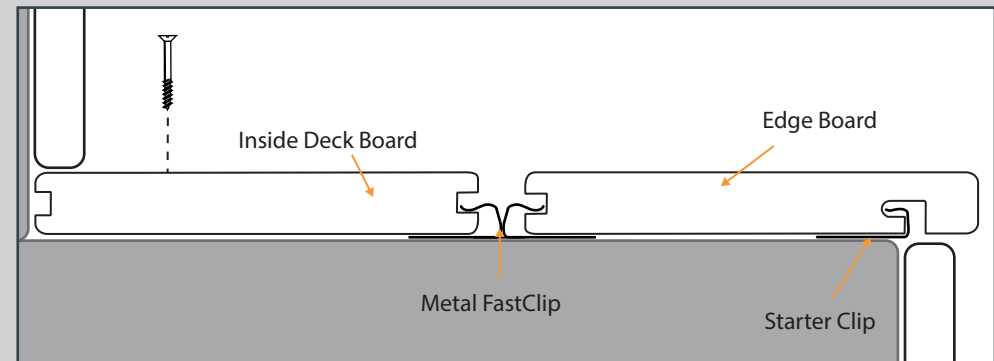

Option B: Plastic FastClip Installation

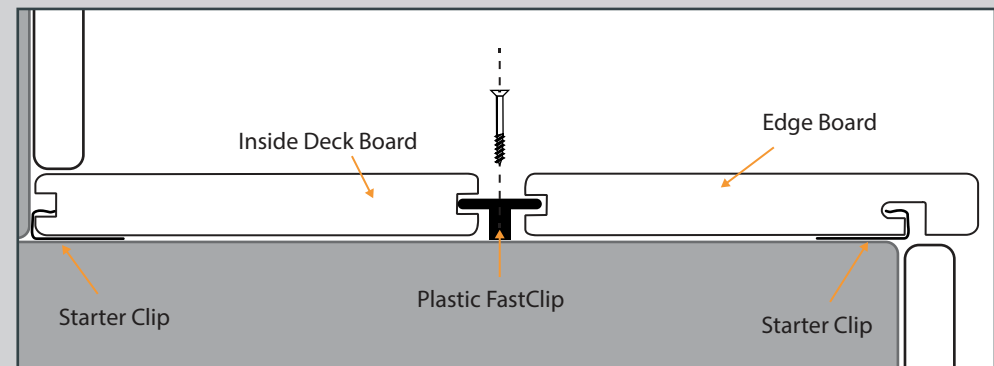

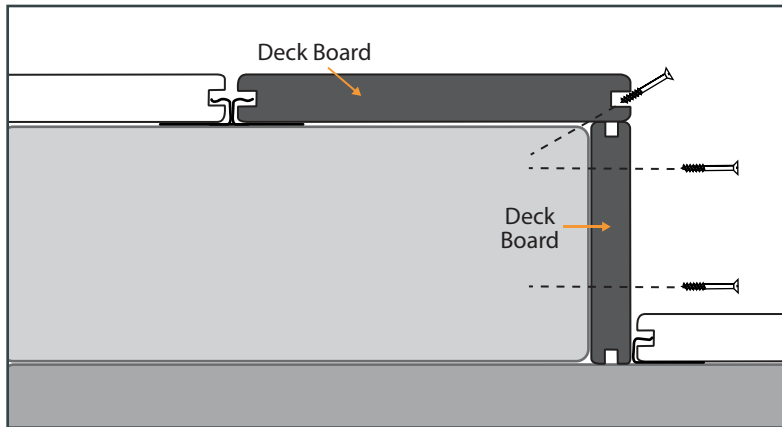

## 2 Using NeoTimber Deck Board

Fix the NeoTimber deck board to form both the tread and rise of your steps, installing directly onto your step framework using our clip system where accessible. Screw fix the exposed grooved edges or face fix the board with a composite screw.

## 3 Using NeoTimber Skirting Trim

Face fix the NeoTimber Skirting Trim to the step framework to form the fascia for the rise of the step.

Pre-drill an over-sized pilot hole prior to screwing and attach securely using a NeoTimber Coloured Trim Screw.

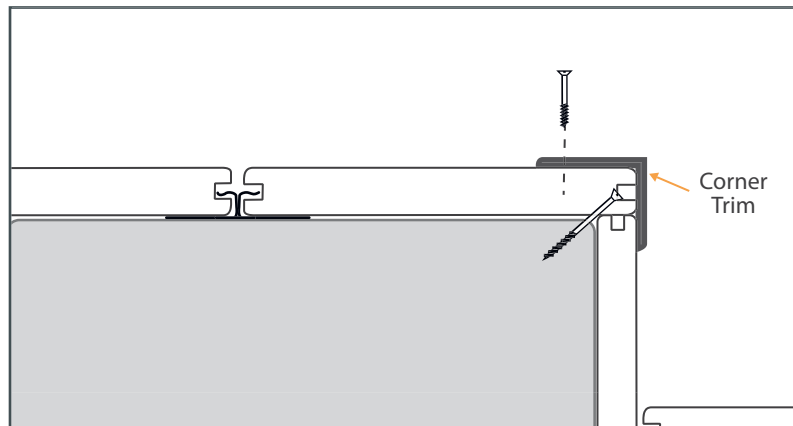
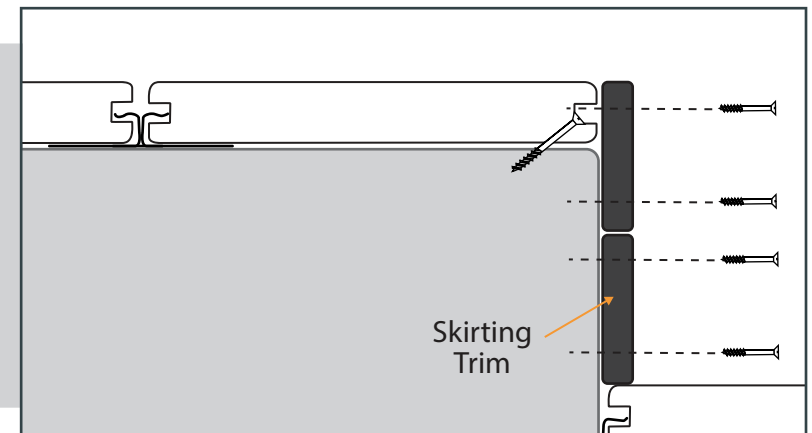

## 4 Using NeoTimber Corner Trim

Face fix the NeoTimber Corner Trim to the exposed edge of the board.

Pre-drill an over-sized pilot hole prior to screwing and attach securely using a NeoTimber Coloured Trim Screw.



**NeoTimber**<sup>®</sup>  
COMPOSITE DECKING

## CARE GUIDE **USEFUL TIPS**

Our low-maintenance composite decking comes with the reassurance of continual performance year-on-year, however we know that with a little care and attention once in a while our boards can continue to look their sparkling best. This section will give you some handy tips on how to care for your decking.

## Routine Cleaning

NeoTimber recommend a routine clean of your decking every 3-6 months to clear away dirt, mud and soil that can accumulate and sit on your boards over the course of time.

**For a general clean** - We recommend applying warm soapy water to the surface of the boards and cleaning with a soft bristled brush.

**For a deeper clean** - You can opt for using a jet wash with no greater than 3100 PSI to clear surface debris from your deck. Using the fan attachment, ensure that this is not applied any closer than 250mm away from the surface of the boards. Following these tips will ensure you preserve the long-term finish of the board.

Regardless of which cleaning option you choose, be sure to clean along the length of the boards to avoid accumulation of material that can interfere with drainage.

## Stubborn Spot Stains

For stubborn stains, such as oil and grease marks, we recommend that you use similar techniques outlined in the Routine Cleaning section as well as the advice below:

- Treat the affected area within the first 7-days.
- A water-based composite decking cleaner can be used which is designed specifically to remove oil from the surface of composite deck boards.
- If treating our Essential and Classic ranges, you may lightly sand the surface of the stained area, which will remove the surface layer of the board and lift the stain. The surface of the deck board will appear a lighter tone than the rest of the board initially, but this difference will clear over time as the boards lighten-up. Please note that the protective shell technology on our Advanced and Deluxe ranges means that they are highly stain-resistant and must not be sanded under any circumstances.

## Surface Mildew And Mould Growth

While our boards are resistant to the damaging effects of both mould and mildew growth, this type of growth can occur on almost every outdoor surface and may collect on the surface of our boards. Following the steps in our Routine Cleaning section will help avoid excessive build-up of such growth.

## Water Staining

Although great care is taken in the manufacturing process of our products, residual oils can remain present in our Essential and Classic ranges, which can sometimes leach out and appear as white streaks on the surface of the deck boards. While these water stains will gradually disappear over a period of approximately 6-8 weeks when the boards are exposed to rain water, there are a few methods that you can follow to speed this process up:

- Use warm soapy water to thoroughly clean the affected boards. Again, you may wish to use a jet wash on the affected area to assist with the removal of surface residue.
- To further speed-up this process, use a composite decking brightener, which is specifically designed to remove the residual oils present in the boards.

Our Advanced and Deluxe range deck boards are protected with a polymer sleeve, which ensures the oils within its composite core do not leach-out onto the surface. This makes this type of board highly resistant to the effects of water staining.

## Clearing Ice And Snow

We recommend maintaining a safe deck when the winter hits by ensuring snow and ice are thoroughly cleared from the surface. You can follow the points below to keep your decking protected from the effects of winter:

- Avoid using metal shovels, rakes, hoes and ice chippers and any other sharp objects to clear snow or ice off your deck. Instead use a plastic shovel, otherwise you run the risk of scratching or damaging the surface of the boards.
- We recommend using a salt-free, non-corrosive ice melt which is designed not to leave any residue on the surface of the boards and is generally more effective than salt-based alternatives. This can be laid either prior to a forecast frost or to areas where ice has already formed.
- While rock salt can be used on our composite decking, we advise that this is cleared away shortly after it has been applied to ensure that it does not damage or scratch the surface of the boards.

# NeoTimber<sup>®</sup>

COMPOSITE DECKING

For more helpful information on installing your decking or  
any of our other products please visit [neotimber.com](https://neotimber.com)

**e:** [enquiries@neotimber.com](mailto:enquiries@neotimber.com) | **t:** 01509 323 170 | **w:** [neotimber.com](https://neotimber.com)