



## Installation Guidelines for Timber Windows.



Photo courtesy of Hoban Design

Timber windows produced by members of the Wood Window Alliance are designed and manufactured using the best available techniques to produce performance-rated products.

These guidelines will help to ensure the installation of your windows lives up to their quality, performance, sustainability and looks. They give you confidence that best practice is being followed, whether the manufacturer or a third-party is installing your windows.

Windows within the Wood Window Alliance scheme are delivered to site fully finished – coated, glazed and fitted with hardware in controlled factory conditions. Other windows may be available as joinery items supplied with a primer or stain base coat for site glazing and finishing. It is always advisable to choose factory-finished windows where possible.

### 1. Delivery, storage and handling on site

Units should be brought to site as close to installation time as possible. Check items on delivery to ensure they match the order, the delivery is complete and there are no signs of damage to the products or the wrapping.

Take care not to damage the product during the unloading process. Lift windows and door sets by the outer frame, not by the opening sashes, ironmongery, or glazing bars. Carry them vertically to avoid twisting or distortion of the outer frame and damage to the connecting joints. Don't drag them.

Avoid using metal storage containers, as excessive heat can damage the products. Where containers are used, ensure air can circulate freely to all products on the pallet and avoid storage in direct sunlight.

Store inside on a minimum of three level, full-width, evenly-distributed bearers in a dry, shaded area clear of the ground. Ensure products stored outside are protected from the elements with a waterproof cover, such as a heat-resistant tarpaulin. Allow air circulation between products.

Products should not be stored in a damp room or building - particularly where plastering will be carried out. Avoid storing products flat. Water lying on a horizontal window or door will cause the timber to swell and will invalidate the warranty.

Take care, when using sharp objects, to remove packaging so as not to cause damage to the product or paint finish.

Inspect products regularly while in storage to ensure the conditions are correct and to check the base coat, primer or finish coats are in good condition.

Our joinery products are manufactured to a carefully controlled moisture content in line with the requirements of BS EN 942. Should they get wet in storage or during installation, their finish and operation could be compromised.

### 2. Glazing

All factory-finished products undergo quality checks before glazing and again prior to leaving the factory. It is the installer's responsibility to ensure they are protected against site activities that could mark the glass. Do not use sharp instruments or abrasive pads to remove marks.

Following the revision to the building regulations in guidance document *Approved Document K 2013 for glazing in critical locations*, the customer is responsible for indicating whether special safety glass etc. is required for specific locations.

Glazing warranties only cover units that have been factory-glazed.



### 3. Planning and preparation

Installers shall ensure they:

- Have received and understood all necessary drawings, survey detail etc.
- Carry within their vehicle sufficient fixings, sealants, and architraves/trims for the installation.
- Ensure the availability of adequate protective coverings for the immediate vicinity of the installation and all walkways to the area.
- Have adequate availability of tools and personal protective equipment.
- Protect the safety of the customer and general public where the installation requires portable access equipment for working at height.
- Plan to install and seal the new windows and doorsets on the same day that the existing windows or doorsets are removed.
- Have in place arrangements for ensuring that, when unavoidable circumstances arise, structural openings, windows, and doorsets can be made secure and weathertight.
- Give the customer sufficient notice of the sequence of installation and for the removal of any furniture, fittings or fixtures that may be damaged during the installation.

### 4. Removing existing windows

First, measure both the existing structural opening and the new window or doorset to make sure they fit. If you are concerned about any discrepancies, resolve the issue before you start any removal.

Avoid unnecessary damage to the structural opening and its surrounding finishes. This will save time spent on making good later on.

If you expose any potentially hazardous materials during the removal, stop work immediately and seek guidance from the window manufacturer.

Removed windows and doors are a hazard. As soon as you take them out, move them to a safe place until they can be dealt with properly. Most of the materials will be recyclable.

Ensure all safety precautions are taken, for example when working at heights, and that suitable protection equipment is worn, for example goggles, hard hats, safety shoes, gloves, wrist protection.

#### Removing timber windows

First, remove all opening lights, complete with their glass, by levering the screws from the frame, or unscrewing or cutting through the hinges.

Take care to remove fixed light glazing safely. If possible, take the glazing out in one piece by removing the putty, sprigs or fixing nails. If you

have to break the glass, ensure the fragments fall on the outside.

After removing the opening lights and fixed light glazing, cut through any mullions and transoms and remove them from the outer frame.

If you cannot locate original fixing nails or screws, you will have to cut twice through the outer frame to remove a small central piece so you can lever the frame from the aperture, causing the minimum damage to the opening.

#### Removing metal windows

There are two types of metal windows that will need removing: aluminium and steel.

Aluminum windows are typically set into timber sub-frames. Locate and remove the screws holding the frame to the sub-frame (this might require removing the glass), then remove the timber sub-frame as described earlier.

Steel windows are often set directly into brickwork or concrete, secured by lugs attached to the outer frame. Remove opening lights and cut through any transoms and mullions with an angle grinder or hacksaw to remove.

Locate the screws holding the frame to the fixing lugs and either unscrew or punch through the frame, before levering it over the lugs.

#### Removing plastic windows

Remove glazing beads, release any glazing tape using a knife blade between frame and glazing and remove all glazing before removing the opening lights by unscrewing their hinges.

Remove any trim profiles around the window or doorset frame to allow easier access and to determine what kind of fixing has been used.

Plastic windows and doorsets are often secured by through-frame fixings or fixing brackets. Through-frame fixings can usually be unscrewed to allow removal of the frame from the structural opening.

If fixing brackets are used, remove any mullions and transoms, cut the outer frame and lever each section out. Try to unscrew the fixings from the brackets; otherwise lever out each fixing bracket carefully.

#### Removing sub-cills

Sub-cills (and sometimes heads, window boards, and mullions) are often 'horned' into the fabric of the structural opening. When cutting and levering them out, take care to keep damage to plaster, renders and brickwork to a minimum. If you damage the DPC, it must be properly repaired or replaced.



### 5. Forming openings

Windows can be fitted either during the course of construction or into pre-formed openings at a later stage.

Don't fit too tightly as this can lead to distortion of the frame. Side clearances however should not exceed 10mm on each side.

When not building-in, openings can be formed using either proprietary templates or site-constructed templates. These templates should produce openings that are in the order of 10mm to 20mm larger than the actual window size.

In exposed conditions, consider using a rebated check reveal. (Figure 1)

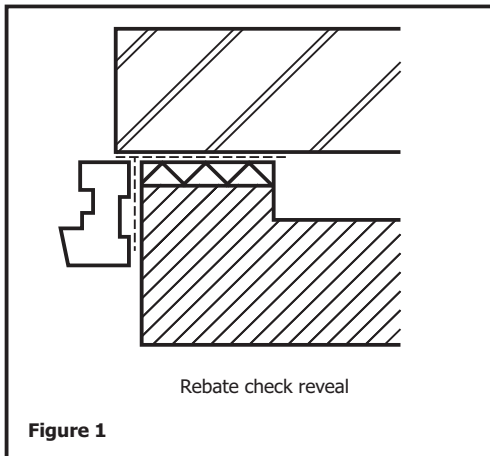

Figure 1

### 6. Fitting

Fit DPCs as the construction proceeds, either by:

- fixing the DPC to the frame prior to building in
- or by fitting the DPC into the structure when making pre-formed openings.

In the latter case, it is often convenient to use a DPC that is wider than necessary. (Figure 2)

Avoid forming a cold bridge, which could lead to condensation.

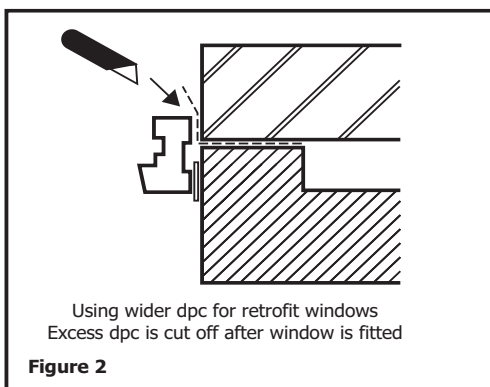

Figure 2

### 7. Support

When building-in, use a mortar bed to provide continuous support at cill level. To prevent the mortar becoming too thin under the weight of the window, it may be necessary to support the window temporarily while the mortar bed sets.

Otherwise, support windows on durable packings at a maximum of 150mm from each jamb and beneath mullions.

The window should be fitted level and plumb. (Figure 3)

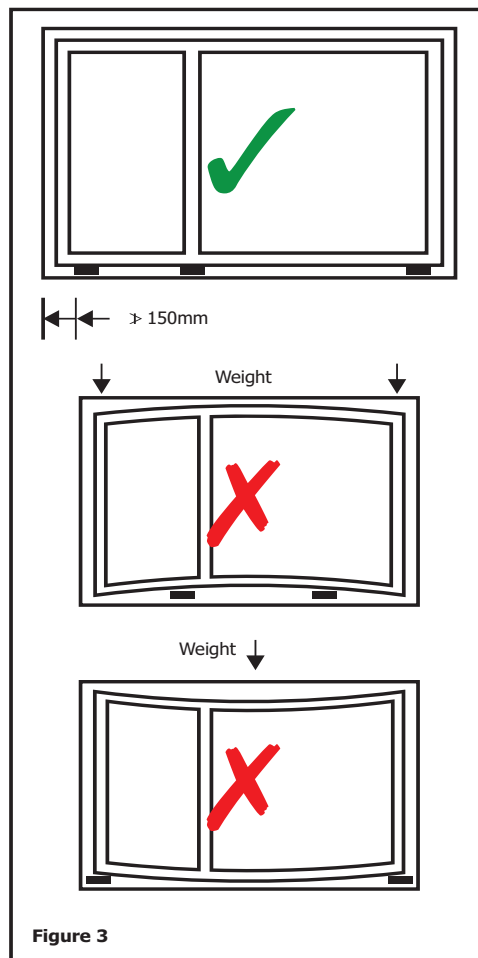

Figure 3

Support for the frame should prevent distortion and avoid damaging any protection or finish.

Locate side packings where fixings occur and ensure the window is fitted without distorting the frame.

Take particular care when providing packings for sliding sash windows, as even minor distortions can prevent movement of the sashes or introduce excessive clearance. (Figure 4)

Check the operation of the window before final fixing.

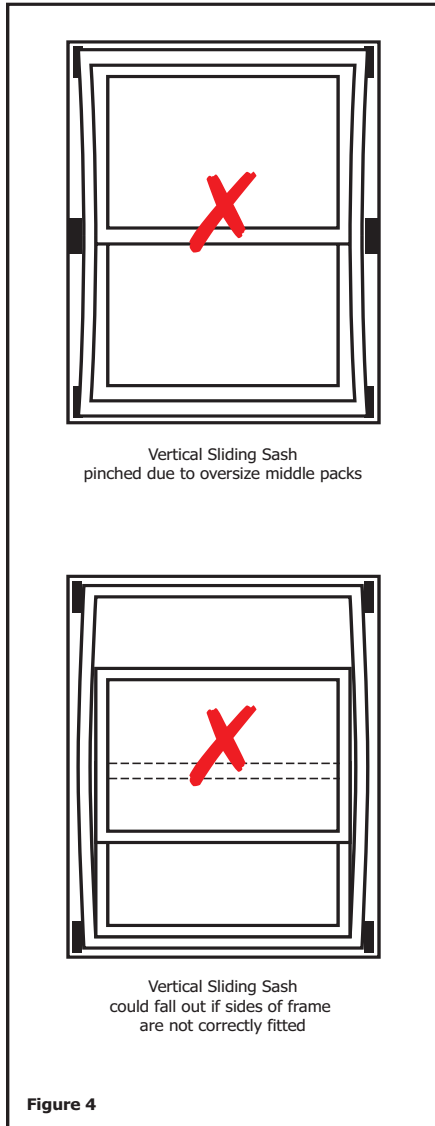

Special requirements may be necessary when fixing windows into preformed openings. Unless internally fitted fixing clips are used (*Figure 6*) you will have to fix through the frame. Choose unobtrusive locations.

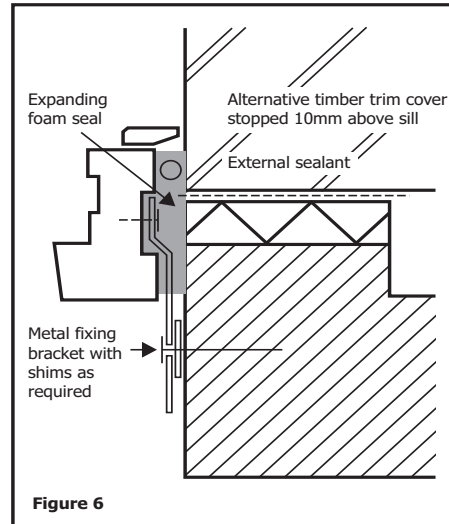

Insulated cavity closers should be installed where appropriate, specific guidance on usage will be available from the manufacturer.

Purpose made nylon frame fixings are available, usually supplied complete with the screw. These use the same diameter hole through the timber as the substrate.

Alternative fixings include a proprietary screw device, which enables the window to be adjusted in position on the screw fixings.

(*Figure 7*)

## 8. Fixings

Side fixings should generally be between 150mm and 250mm from the top and bottom of the frame and no more than 600mm between centres.

Where a window is more than 1800mm wide or formed from two or more units, provide fixings at both the head and cill (*Figure 5*).

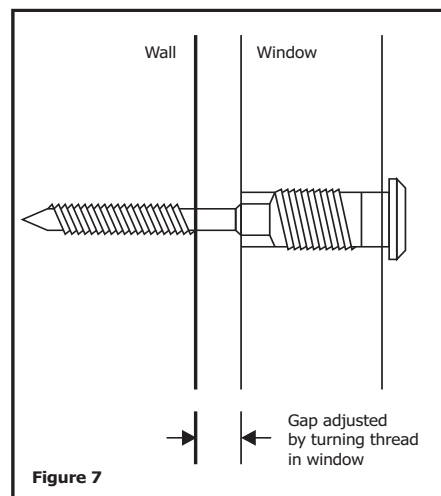
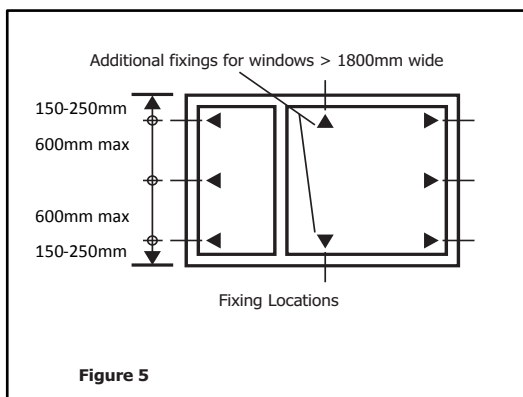



## 9. Sealing

### Perimeter sealing of windows and doorsets

The gap between the window or doorset and the aperture should be sealed to repel water and prevent air leakage while allowing for any movement that may occur between the frame and the aperture.

Replacement windows and doorsets need only be sealed on the outside, whereas in new build sealing is required to both the inside and the outside. The correct sealant, selected to suit the construction and frame materials involved, will maintain its flexibility and adhesion throughout its service life. The sealant could either be a wet sealant or an impregnated foam tape.

### Wet sealants

Wet sealants, e.g. silicones, should be tested and classified in accordance with **BS EN ISO 11600**<sup>1</sup> as class 20LM or 25LM (meaning they are low modulus with a movement capability of 20% or 25%). They should also be neutral curing, with good adhesion.

**Sealant manufacturers**<sup>2</sup> can be consulted on sealing large gaps and on sealant adhesion to specific substrates and materials and on whether primers are required. They can also propose sealant/primer systems, which will minimize the potential for staining.

The presence of old oil-based mastics and bituminous DPCs can adversely affect the behaviour or appearance of otherwise correctly specified and applied 'wet' sealants. This risk should be avoided by removal of unwanted mastic and by keeping newly applied sealant away from DPCs.

In situations where sealants rely upon atmospheric moisture to initiate curing, deep filling should be avoided.

For larger gaps a wet sealant should be applied against a firm backing, such as a closed-cell, circular, foam strip, so that it is forced against the sides of the joint during application. The sealant should not adhere to the foam strip.

### Impregnated foam tapes

They should remain permanently flexible and accommodate at least the same joint movement as a 'wet' sealant as classified above. They should comply with DIN 18542 with exposure category of BG1.

Foam tapes do not require primers as they are held under compression within the joint, rather than relying on adhesion to the substrate.

#### Notes

<sup>1</sup>British adhesives and sealants association (BASA), Guide to the use of BS EN ISO 11600

<http://www.basaonline.co.uk/publications/guides.aspx>

<sup>2</sup>British adhesives and sealants association (BASA) list of members

<http://www.basaonline.co.uk/membership/listofmembers.aspx>

**BS EN ISO 11600:2003+A1:2011**, Building construction. Jointing products. Classification and requirements for sealants

**DIN 18542**, Sealing of outside wall joints with impregnated sealing tapes made of cellular plastics - Impregnated sealing tapes - Requirements and testing.

## 10. Decoration

Wherever possible, windows and doors should be factory finished. Any further finishing should be carried out in dry weather using good exterior quality materials in accordance with the manufacturer's instructions (see the BWF's 'Care of timber windows on site' for advice).

**Note:** *Whilst every effort has been made to ensure the accuracy of advice given, the federation cannot accept liability for loss or damage arising from the use of the information supplied in this publication. This document is due to be updated in 2015 in line with revisions to BS 8213-4.*



Mumford & Wood Limited  
Tower Business Park, Kelvedon Road, Tiptree, Essex CO5 0LX  
T: 01621 818155  
E: [sales@mumfordwood.com](mailto:sales@mumfordwood.com)  
W: [mumfordwood.com](http://mumfordwood.com)