

8 Channel Dimmer Module



An eight circuit dimmer module rated at 500W per circuit for the control of resistive and inductive lighting loads with the facility to select dimming or switched only operation of any circuit. A custom designed housing provides reliable power handling in a compact format.

Modules may be used in a standalone mode with simplified functionality providing programmable scene setting or Impulse (ON/OFF/DIM) type control from a single keypad. Alternatively conventional momentary switches can be linked to a Contact Input Module (DIN-INT-00-08) to provide Impulse control of up to eight lighting circuits using eDIN Dimmer Modules.

An on-board menu system provides simple setup of circuit functions, maximum and minimum dimming levels, circuit test facility and power percentage monitoring. eDIN Dimmer modules may also be used in conjunction with a Network Processor Module to provide flexible, adaptable control for small to medium scale projects.

Key Features

- » 8 x 500W Dimmer Module (total 10A maximum).
- » Leading Edge Dimming.
- » Compact 9M width DIN Rail Mounting Module.
- » Selectable dimming or switching operation.
- » Programmable circuit Cap and Cup levels.
- » M-BUS enabled.
- » Low Load Compatible.
- » Operates resistive and inductive loads including low voltage electronic transformers (leading edge compatible type only).
- » Energy Saving Display.
- » Quiet operation.
- » Can be installed as part of a 17th Edition Compliant installation.
- » ISO9001 certified design and manufacturing facility.
- » 2 year warranty.



System Architecture

Networked

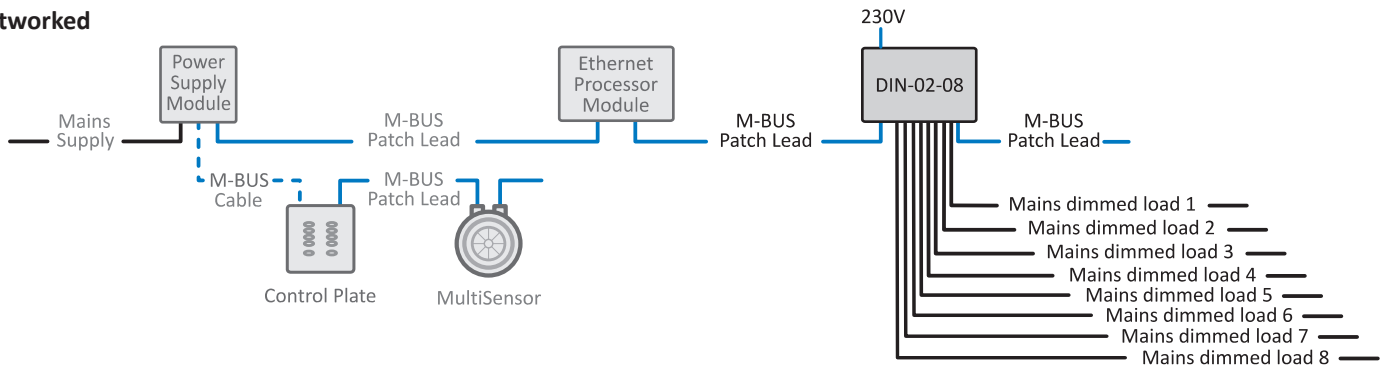

Standalone

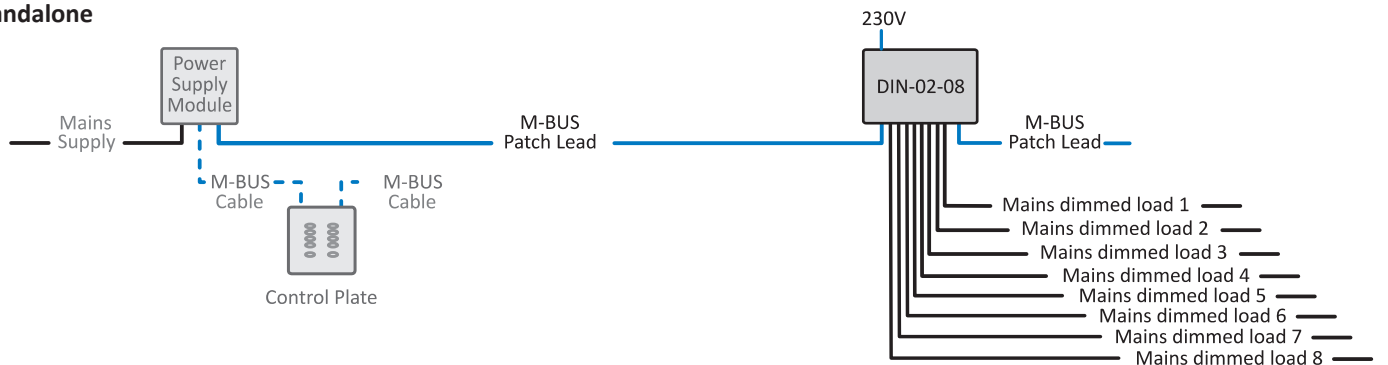

Technical Data

Power	
Mains Supply	» 230V AC +/- 10% @ 50/60Hz single phase
Output Type	» Mains dimmed, Leading Edge
Channel Load	» 2A (≈500W) maximum per channel, resistive or inductive load
Module Load	» 10A Maximum
Connections	
Control Input	» MBUS
MBUS Current Consumption	» 80mA
Output Control Type	» 8 dimmed live outputs » 8 neutral connections » 8 earth connections » Rising cage screw terminals (max. wire size 1.5mm)
Mechanical & Standards	
Material	» Extruded aluminium case
Dimension	» 156mm Wide x 100mm High x 64mm Deep
Standards CE, EMC and low voltage directives	» EN55015, EN61547, EN61000-3-2, EN61000-3-3 and EN60669-2-1
Weight	» 0.95Kg
Module size for DIN enclosure	» 9 Module (9M)

Note

For additional technical information refer to Installation Guide DIN-02-08-PLUS.

