



Metsec plc
Lightweight Structural Systems
SFS Division
Broadwell Road, Oldbury
West Midlands B69 4HF
T. +44 (0) 121 601 6000
F. +44 (0) 121 601 6021
E. sfs@metsec.com

Metsec SFS Installation Manual

Load Bearing

September 2009

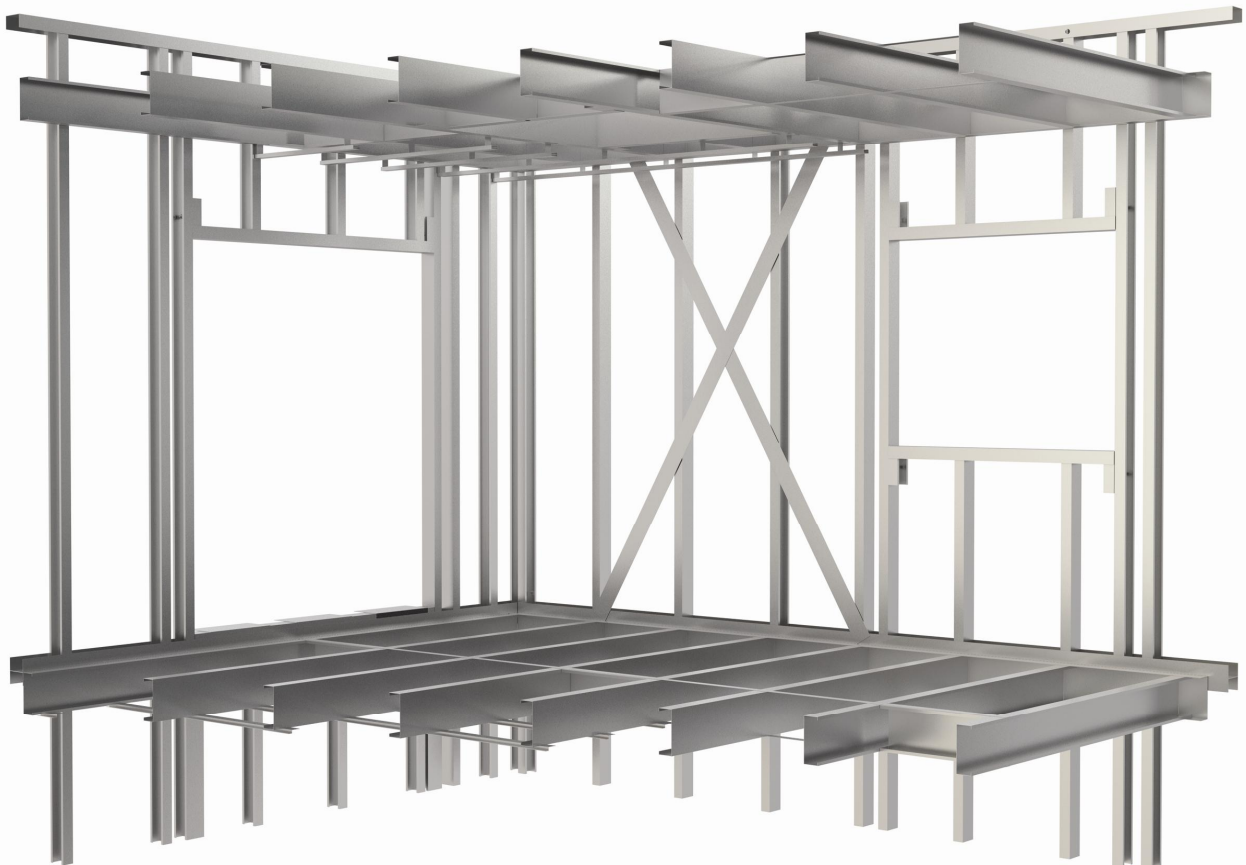

www.metsec.com

Registered in England No. 1551970.
VAT No. GB 428 7252 38. Registered office as above.

voestalpine

ONE STEP AHEAD.

Contents

Section

Introduction	0
Product Description : SFS	0
Components : SFS	0
Metsec Framing Section Range : SFS	0
SFS Site Installation	0
Details for Base Track Installation (SF100 series)	1
Details for Stud Installation (SF300 series)	2
Details for Framing Openings (SF400 series)	3
Details for Floor & Roof Joist Installation (SF600 series)	4
Details for Loadbearing Structures (SF700 series)	5
Details for Finishes (SF800 series)	6
Fixing Application Guide	A



Introduction

Metsec PLC manufactures a comprehensive range of cold rolled steel profiles for both the construction and manufacturing industry.

The company was established in 1932 and is now a wholly owned subsidiary of the Austrian steel manufacturer, VOEST ALPINE STAHL AG.

Metsec Framing division was formed in 1984 and forms one of eight divisions within Metsec. The other divisions are Purlins, Hepsec, Lattice Beams, Metstrut, CRF, Manipulation (MPM) and Windows.

Metsec Framing division has two main products, SFS and Meframe. The SFS product is split further into four distinct product groups: Infill External Walling, Continuous External Walling, High Bay Walling and Load Bearing Structures. This installation guide deals only with the SFS Load Bearing Structures system. For guides for SFS Walling and Meframe please contact Metsec.

The key objectives of this guide are to provide:

- General details showing the typical fixing requirements which can be used by installers on site along with project specific designs and drawings to install the SFS product.
- Information for installers to assist with the preparation of specifications, method statements and risk assessments.
- Site reference guide for contractors.

Throughout this manual Metsec Framing will be referred to as Metsec.

All text & drawings contained in this document are the property of Metsec and must not be copied or printed, in part or in full, without prior written agreement from Metsec.

All text & drawings contained in this document show typical details and reference to project specific drawings & calculations should be made for confirmation of section sizes / connection details.

Whilst every effort has been taken to ensure this manual contains full & accurate information Metsec cannot accept any liability for errors or omissions. The contents constitute advice, given in good faith.

Where details show overall construction this does not imply agreement by Metsec or the installer to provide all elements shown.

Metsec reserves the right to change details and specifications at any time, without prior notice.



Product Description - SFS

SFS is a fast-track solution to construct external walling, high bay separating walls and load bearing elements in lightweight cold-rolled galvanized steel sections.

SFS has been extensively used in construction projects covering residential flats, apartments, nursing homes and sheltered accommodation, commercial developments, public buildings and industrial properties. It is also ideally suited to refurbishment projects, particularly involving sub-division of buildings, conversions or roof extensions.

SFS projects are usually designed in house by Metsec's team of engineers and typical details and calculations are provided to aid construction.

Sections are typically supplied to site as individual components and fully assembled in-situ. This is an advantage where site access/craneage is restricted. Components can be supplied in final required lengths or standard lengths cut to suit on site. By cutting to length on site construction tolerances in structures being worked alongside can be fully accommodated.

Generally SFS sections are fixed together using self-drilling / self-tapping (Tek) screws.

SFS External Infill Walling requires support at the slab edge between a hot-rolled steel or concrete frame structures. This allows insulation and external finishes to be installed continuously outside the main structural frame. The system is suitable for both low and high-rise constructions.

SFS External Continuous Walling is fitted outside the line of the structural frame using support cleats at each floor level with connections designed to allow slab deflection. It is particularly suited to situations where cladding materials are sensitive to differential movement of the mainframe.

Both the above systems achieve early weather protection of the building allowing other internal fitting trades to work inside the structure and removing external cladding from the critical path.

SFS external walling will provide lateral support to most cladding materials including masonry, profiled metal sheets, proprietary panels and insulated render systems.

SFS High Bay Walling is a single-span separating wall typically used within existing buildings such as warehouses and industrial units. Its lightweight construction and uniformly distributed loading minimizes disruption to the existing structure.

SFS Load Bearing Structures are used to provide individual elements or a complete stand-alone structure. Roofs, floors and internal walls are lightweight, quick to install and flexible in detail and performance characteristics.

SFS structures are particularly suited to developments where access is limited or lightweight loadings are required eg/extensions supported by existing structures.

Only SFS Load Bearing Structures are covered in this guide.



Components - SFS

The following tables show the Metsec Framing standard section ranges for SFS.

These consist of the section profiles listed below;

- 'C sections': Used as studs in wall panels and joists in floor panels.
- 'Channels': Used as tracks on top and bottom of wall panels and ends of floor panels.
- 'Angles': Used for various arrangements to provide additional or temporary support.
- 'Straps': A range of straps is available to use as bracing members when screw fixed to face of wall panels.

Examples of section references are:

100M12 = Lipped C section of 100mm depth, 1.2mm material thickness.
'M' reference denotes SFS section.

104M12 = Non-lipped channel section of 104mm depth, 1.2mm material thickness.

Where necessary the Metsec SFS range of sections can be used in conjunction with other ranges produced in the Metsec Framing Division.

All components are formed from pre-hot dipped galvanized steel G275 coating, minimum yield strength = 280N/mm².

All other components shown in our details but not listed in our range are not supplied by Metsec.



Metsec Framing Section Range - SFS

Section Reference	Area cm ²	Weight kg/m	D mm	F1 mm	F2 mm	L mm	t mm	Service Slot
70M15	2.31	1.83	70	35	35	10	1.5	72x32
100M12	2.75	2.14	100	53	53	14	1.2	72x32
100M15	3.45	2.67	100	54	54	14	1.5	72x32
100M20	4.60	3.56	100	55	55	14	2.0	72x32
100M23*	6.04	4.67	100	71	71	15	2.3	72x32
100M29*	7.67	5.83	100	72	72	16	2.9	72x32
100M30*	10.56	8.26	100	110	110	22	3.0	72x32
150M12	3.37	2.64	150	55	55	13	1.2	72x32
150M15	4.23	3.37	150	56	56	13	1.5	72x32
150M20	5.64	4.47	150	57	57	13	2.0	72x32
150M30*	8.76	6.83	150	62	62	15	3.0	72x32
200M12	3.97	3.13	200	55	55	13	1.2	72x32
200M15	5.28	4.18	200	65	65	14	1.5	72x32
200M20	7.08	5.56	200	67	67	14	2.0	72x32
200M30*	10.56	8.26	200	68	68	14	3.0	72x32
250M16	6.55	5.11	250	68	68	15	1.6	72x32
250M20	8.16	6.38	250	68	68	15	2.0	72x32
300M20	8.80	6.97	300	59	59	15	2.0	72x32
300M29	12.83	10.1	300	62	62	15	2.9	72x32
74M12	1.82	1.47	74	40	40	0	1.2	None
74M20	4.00	3.26	74	65	65	0	2.0	None
104M12	2.71	2.14	104	62	62	0	1.2	None
104M15	3.38	2.67	104	62	62	0	1.5	None
104M20#	4.52	3.56	104	63	63	0	2.0	None
108M30*	6.78	5.35	108	62	62	0	3.0	None
154M12	3.33	2.64	154	63	63	0	1.2	None
154M20#	5.64	4.47	154	66	66	0	2.0	None
158M30*	8.70	6.83	158	69	69	0	3.0	None
204M12	3.93	3.13	204	63	63	0	1.2	None
204M20#	6.96	5.56	204	74	74	0	2.0	None
208M30*	10.38	8.26	208	72	72	0	3.0	None
254M12	3.93	3.13	254	38	38	0	1.2	None
254M20	8.00	6.38	254	79	79	0	2.0	None
304M16	6.41	5.11	304	53	53	0	1.6	None
304M20	8.72	6.97	304	68	68	0	2.0	None
306M29	12.65	10.1	306	68	68	0	2.9	None
38VB09	0.34	0.27	38	0	0	0	0.9	None
100VB12	1.20	0.94	100	0	0	0	1.2	None
45x45x2.0	1.76	1.38	0	45	45	0	2.0	None
100x100x2.0	3.96	3.11	0	100	100	0	2.0	None

* - Non-Standard section sizes. Availability and lead in times may vary from typical periods.

- Section is available with deflection head slots with an 'S' reference i.e. 104M20S.

When provided the service slot is on the centre of the web.

All other components shown in our details but not listed in our range are not supplied by Metsec.

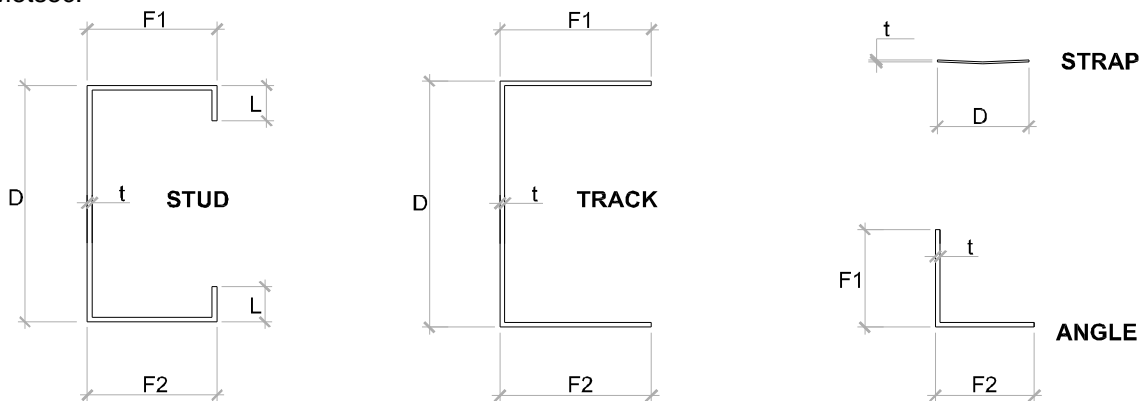

SFS Load Bearing Structures – Site Installation

To be read in conjunction with all details in sections 1 to 6 and also project specific calculations and drawings.

Please note that any details shown in project specific calculations/drawings take precedent over general details within this installation guide.

The details in this guide are split into sections which follow a sequence similar to how the systems should be constructed on site.

GENERAL SITE PROCEEDURE GUIDANCE NOTES

It is the installer's responsibility to produce a cutting list and order Metsec materials. This should be co-ordinated to suit the desired construction programme.

The installer should conduct a site survey to establish the as built dimensions of the 'main frame' to enable material to be ordered in the most economic manner, alternatively material can be cut to suit on site. Splices in sections are not permitted except where specifically designed by Metsec.

The following points are guidelines that the installer should carefully consider before producing his site-specific method statement:

- SFS Sections are delivered to site in bundles on an articulated lorry unless requested otherwise.
- When lifting bundles and hot-rolled steel using a crane a tail line must be used with an operative on the ground to control lift.
- Where materials are put into temporary storage on site it must be in designated areas with suitable protection to prevent damage.
- Any materials that are damaged upon arrival on site or during construction must be reported and replaced.
- Leading edge protection must be in place throughout roof/floor works and adequate barriers provided around stairwells and voids. Alternatively a fall arrest system of air bags or netting may be suitable.
- Where components need to be cut on site they should be cut with a chopsaw with TCT blade and not an abrasive disk. Care should be taken to cut the components square where they are used in right-angled connections, or as required for an angular fit against abutting members.
- Fixing of components shall be with self-tapping screws. Screw type and size shall be as typical details attached / project specific design. Screw details are included in Appendix A. All screw fixings must be installed perpendicular to the surface unless advised otherwise.
- No holes are to be cut or formed in SFS steelwork without prior reference to Metsec.
- 72mm deep x 32mm wide service slots can be provided 600mm from each end of studs when requested.
- All drylining, insulation and boarding must be installed in accordance with the project specification and manufacturers recommendations.
- Drylining specification to be in accordance with the contract requirements for fire protection, thermal and acoustic performance. Wall make-up is to be agreed with the Architect.
- Plasterboard pallets cannot be loaded onto Metsec Joisted Floors unless previously agreed in writing from Metsec and with a loading plan.

Reference should be made to the project specific Metsec drawings and Metsec Design Plan and Assessment



LOAD BEARING STRUCTURES

In all cases project specific design and drawings will be necessary to enable installation. Under no circumstances should these types of structures be built off indicative drawings.

In load bearing structures it is important to use the correct number of fixings as shown even if the number seems excessive. The quantities of fixings have been specified to meet disproportionate collapse requirements as laid out in the building regulations.

Material should be stacked adjacent the area it is to be utilized following storage/loading restrictions applied by the Main Contractor.

It is important that the supporting structure / foundations are correctly set out to receive base tracks. No overhang of the base track is permitted and hence Metsec recommend that the supporting structure is constructed larger than required to allow for construction tolerances.

Base Tracks should be installed as per the **SF100 series** details. No overhang is permitted.

Studs can be installed as per the **SF300 series** of details. Studs shall be plumbed, aligned and securely attached/located within the base and head tracks. The ends of the studs must fit snugly and squarely into the head and base tracks to transfer the loads in the structure. Deflection heads should not be used in load bearing applications unless designed specifically by Metsec.

Openings can be framed as per the **SF400 series** of details. Where compound sections are shown for lintels, cills & jamb studs these sections should be full length and not spliced.

Resistance to bending and rotation about the minor axis shall be provided by blocking and strapping as shown on the drawings and detail **SF361**.

Temporary and permanent bracing may be required to the walls as per details **SF711 to SF714** and should be installed before any floor or roof joists.

Floors and Roofs can be installed following the **SF600 series** of drawings. Track and joist connections can be made using details **SF610 to SF617** using the quantity of fixings shown. Joists can also be installed as per details **SF621 to SF625**. Where joists run parallel to SFS walls or other building elements then they should be connected using details **SF631 to SF637**. Resistance to bending and rotation about the minor axis shall be provided by restraint details **SF641 to SF644** as shown on the drawings. Openings and cold rolled beams can be constructed as per details **SF645** and **SF651 to SF653** when specified on the drawings.

In order to meet disproportionate collapse requirements all connections should have the correct number of fixings as shown on the details and in addition where there the building is more than one storey in height then the wall connections should be as details **SF721 to SF723**.

Examples of various roof constructions can be found in details **SF731 to SF735**. These show typical examples and therefore project specific drawings should be followed.

Details for the fixing of finishes can be found in the **SF800 series** of details and in all cases the installation of these components should be done with to the manufacturers' recommendations.



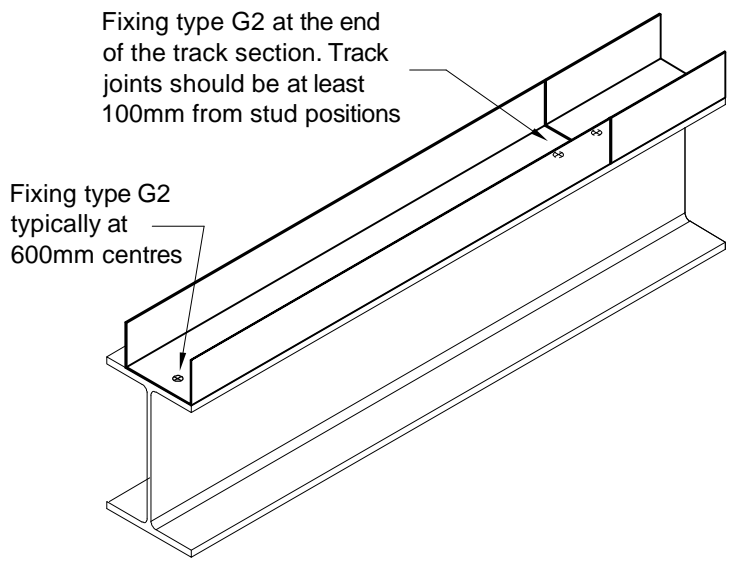

NOTE: For load bearing structures no overhang is permitted

NOTE: Fixings should be close to the centre of the track but outside the edge distance stated

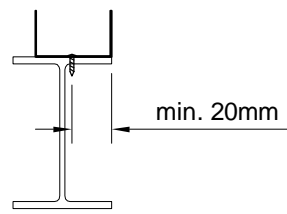

DETAIL SF113

Base Track: Fixing to Steel

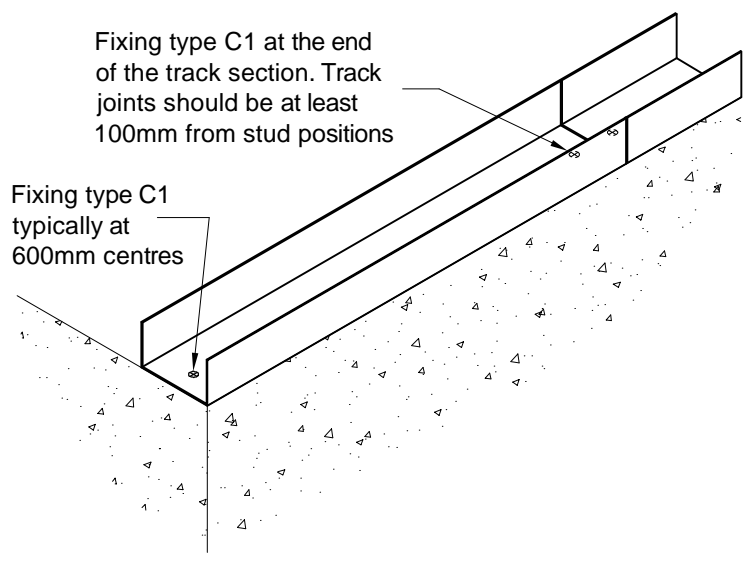

NOTE: For load bearing structures no overhang is permitted

NOTE: Fixings should be close to the centre of the track but outside the edge distance stated

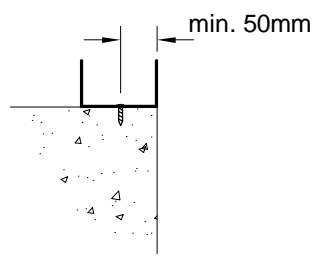

DETAIL SF123

Base Track: Fixing to Concrete



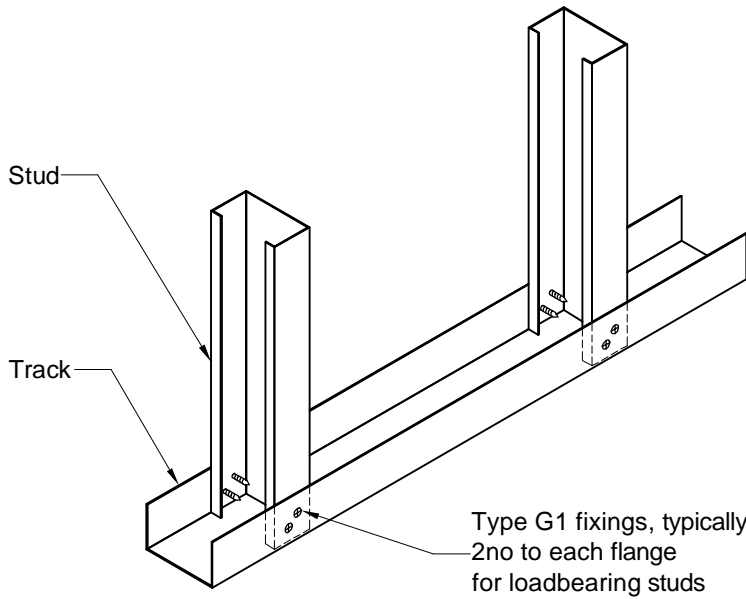

NOTE: The ends of the studs must fit snugly and squarely into the head and base tracks to transfer the loads in the structure

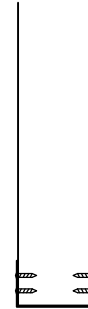

DETAIL SF311

Loadbearing Stud to Base Track Connection

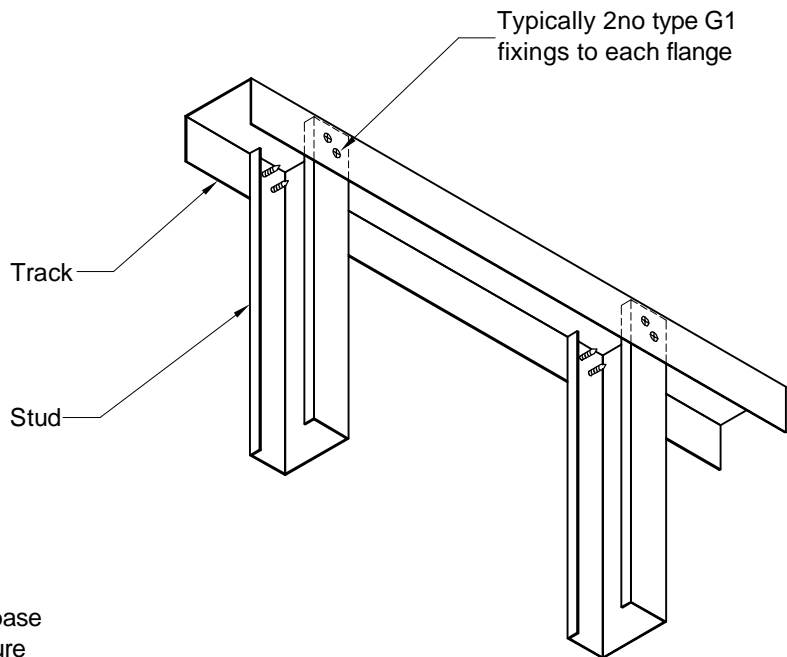

NOTE: The ends of the studs must fit snugly and squarely into the head and base tracks to transfer the loads in the structure

DETAIL SF321

Loadbearing Stud to Head Track Connection

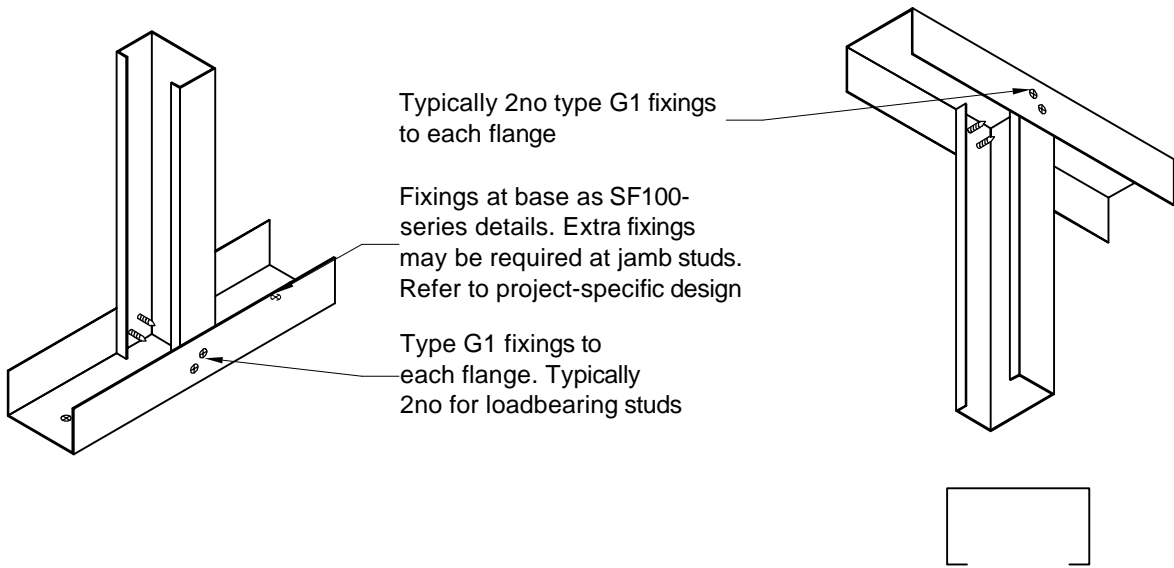

Typically 2no type G1 fixings to each flange

Fixings at base as SF100-series details. Extra fixings may be required at jamb studs. Refer to project-specific design

Type G1 fixings to each flange. Typically 2no for loadbearing studs

DETAIL SF411-5
Single Jamb Stud - No Deflection Head

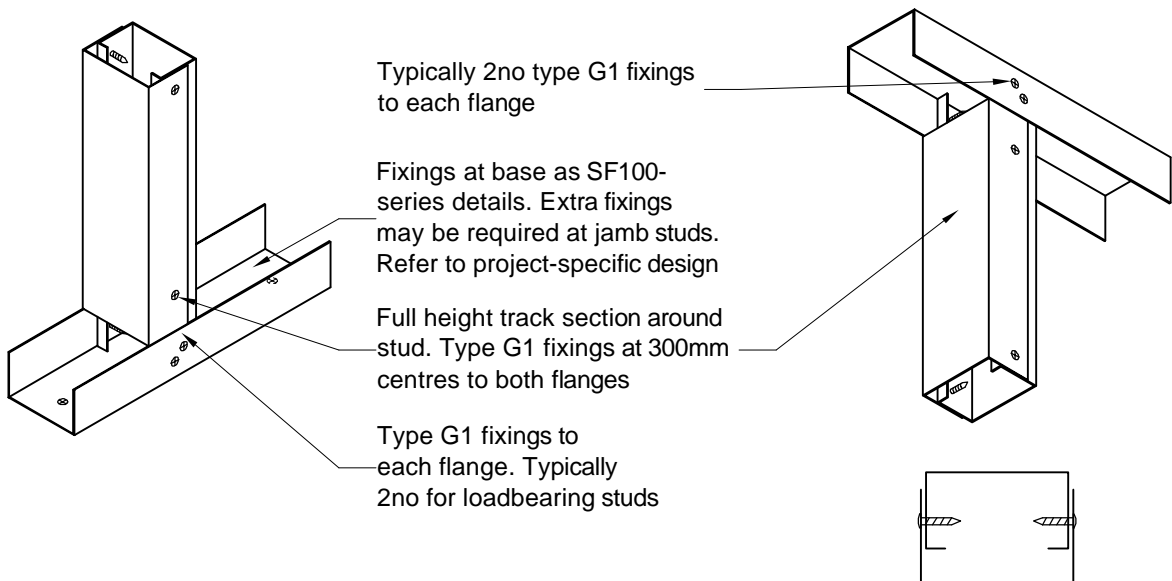

Typically 2no type G1 fixings to each flange

Fixings at base as SF100-series details. Extra fixings may be required at jamb studs. Refer to project-specific design

Full height track section around stud. Type G1 fixings at 300mm centres to both flanges

Type G1 fixings to each flange. Typically 2no for loadbearing studs

DETAIL SF412-5
Compound Jamb - Two-Member Section - No Deflection Head

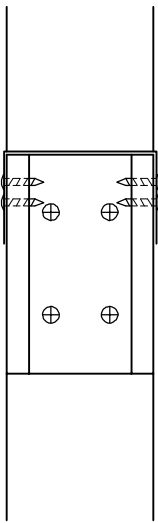

2no type G1 fixings to each flange of stud

Full length track forming base of opening

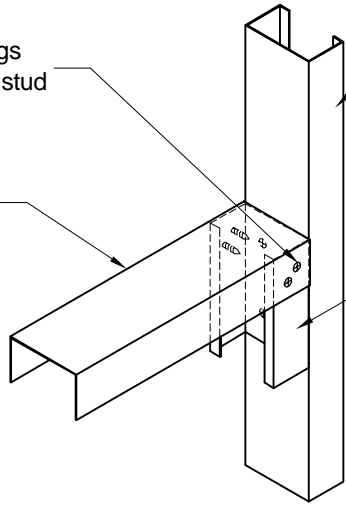

Full height jamb stud

Minimum 150mm section fixed with 4no type G1 fixings to jamb stud

DETAIL SF420

Single Cill

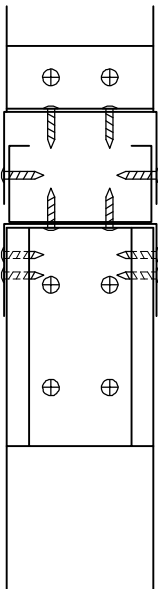

45x45x2 angle cleat fixed to cill and jamb with 2no type G1 fixings each leg

2no type G1 fixings to each flange of stud

Full length stud and 2no track sections arranged as shown. Type G1 fixings at 300mm centres to web and both flanges

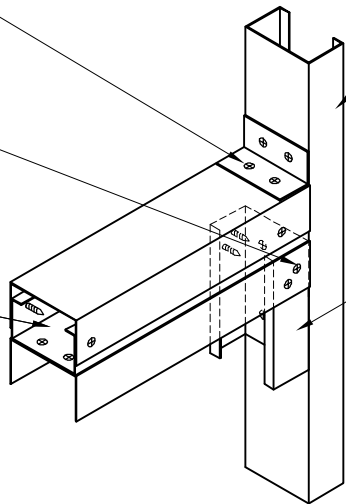

Full height jamb stud

Minimum 150mm section fixed with 4no type G1 fixings to jamb stud

DETAIL SF421

Compound Cill

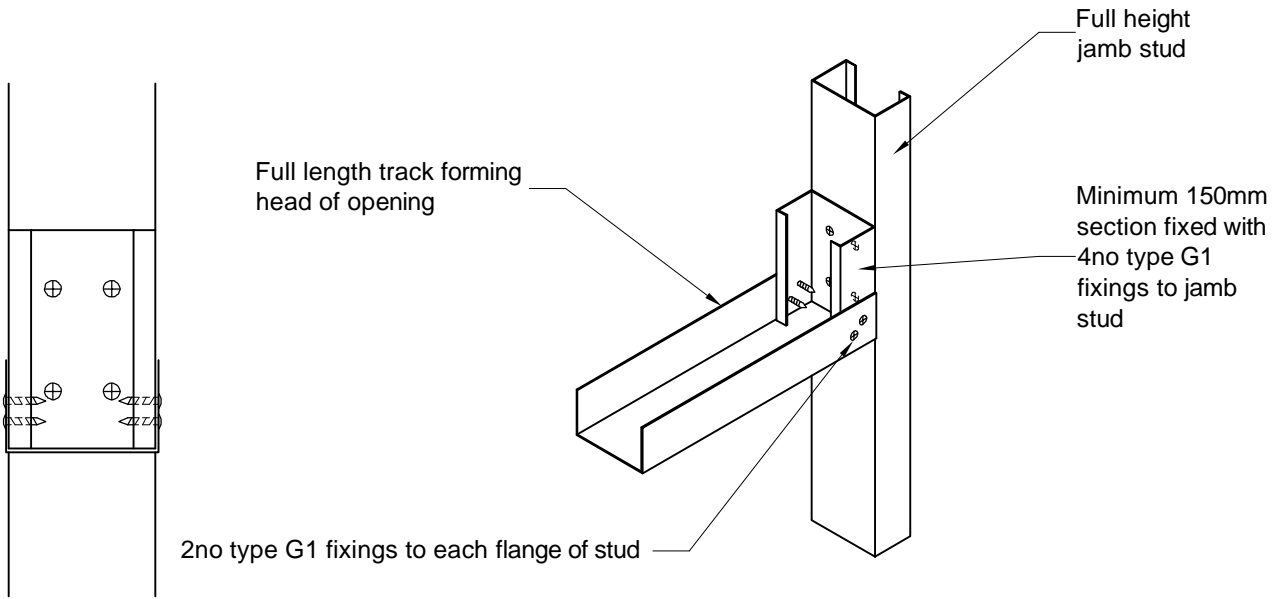

DETAIL SF430
Single Lintel to Single Jamb Stud

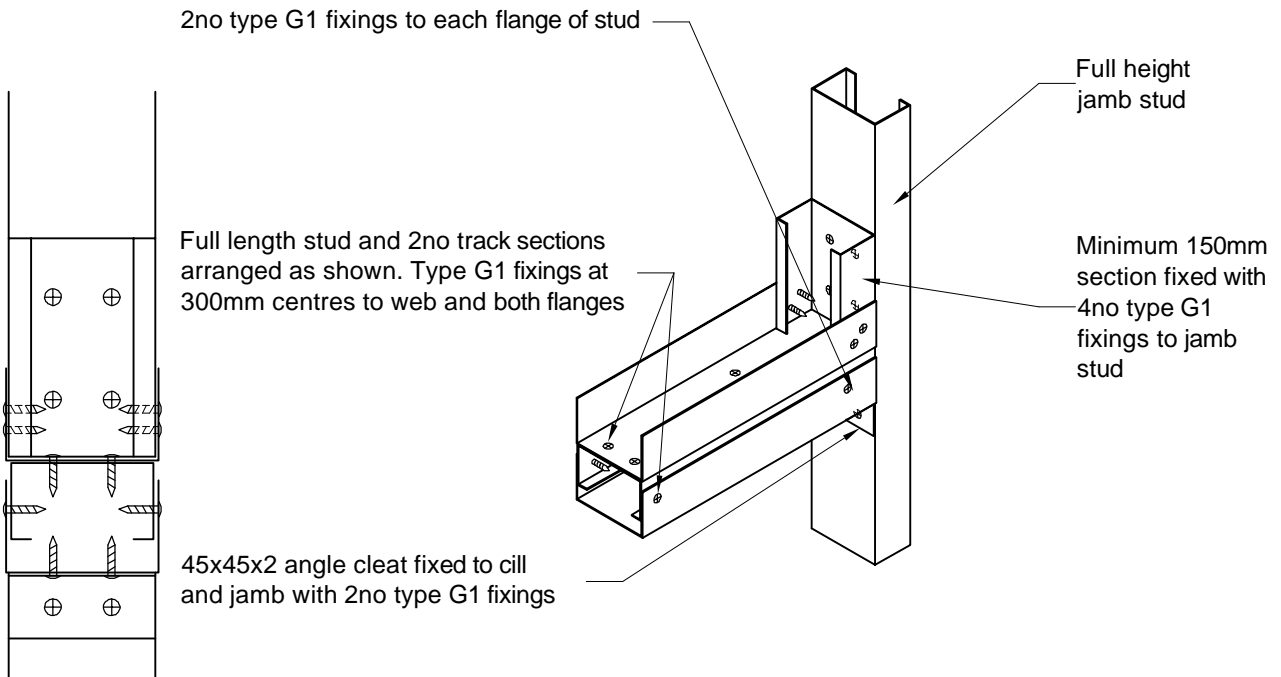

DETAIL SF431
Three-Member Compound Lintel to Single Jamb Stud

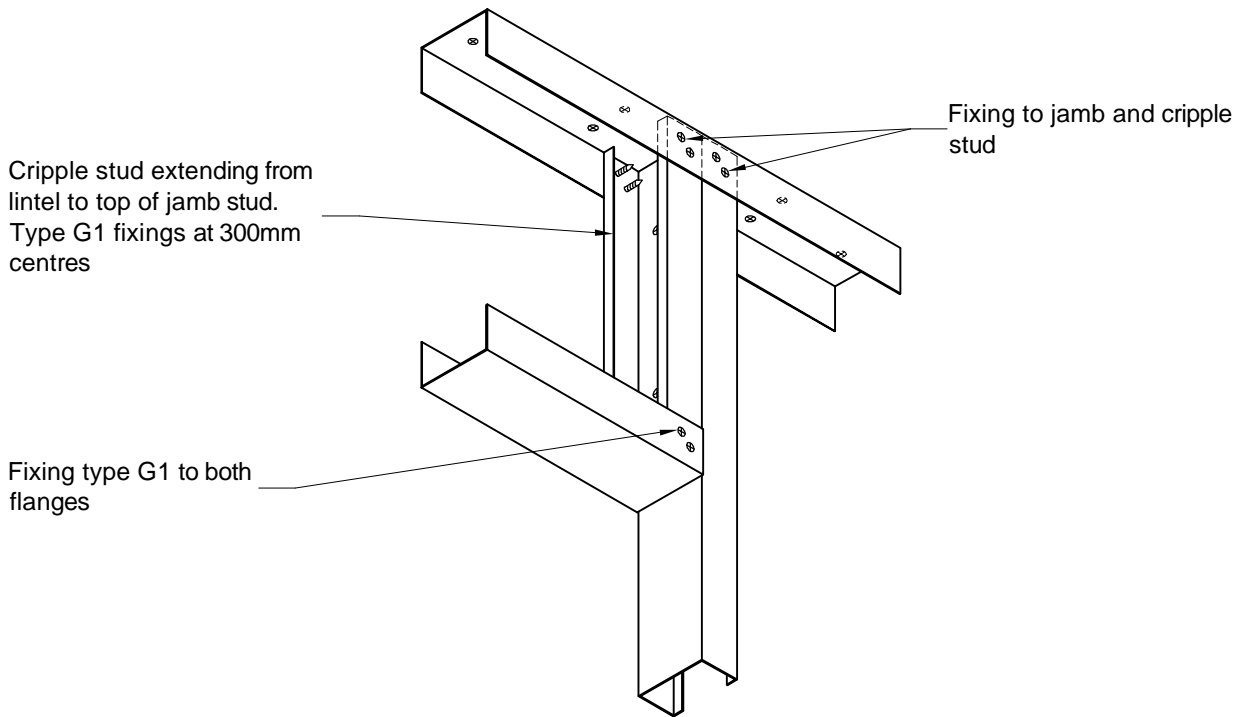

DETAIL SF441-5

High Load Single Jamb - No Deflection Head

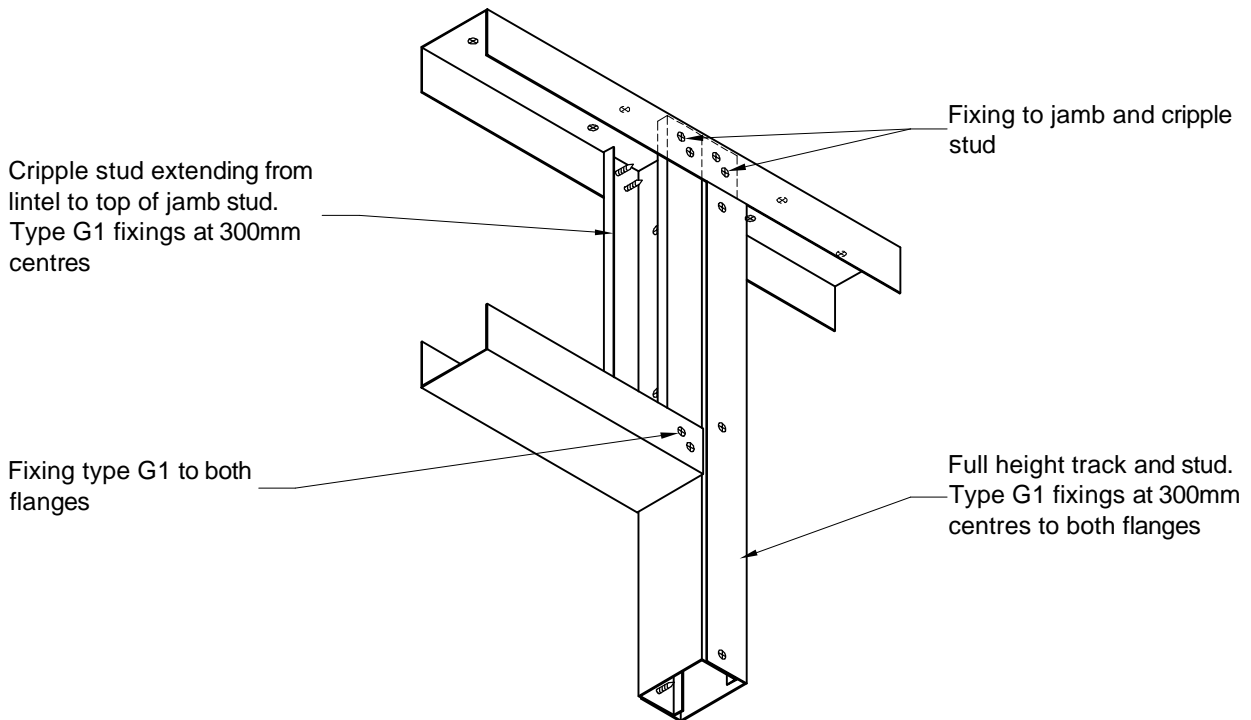

DETAIL SF442-5

High Load Two-Member Compound Jamb - No Deflection Head

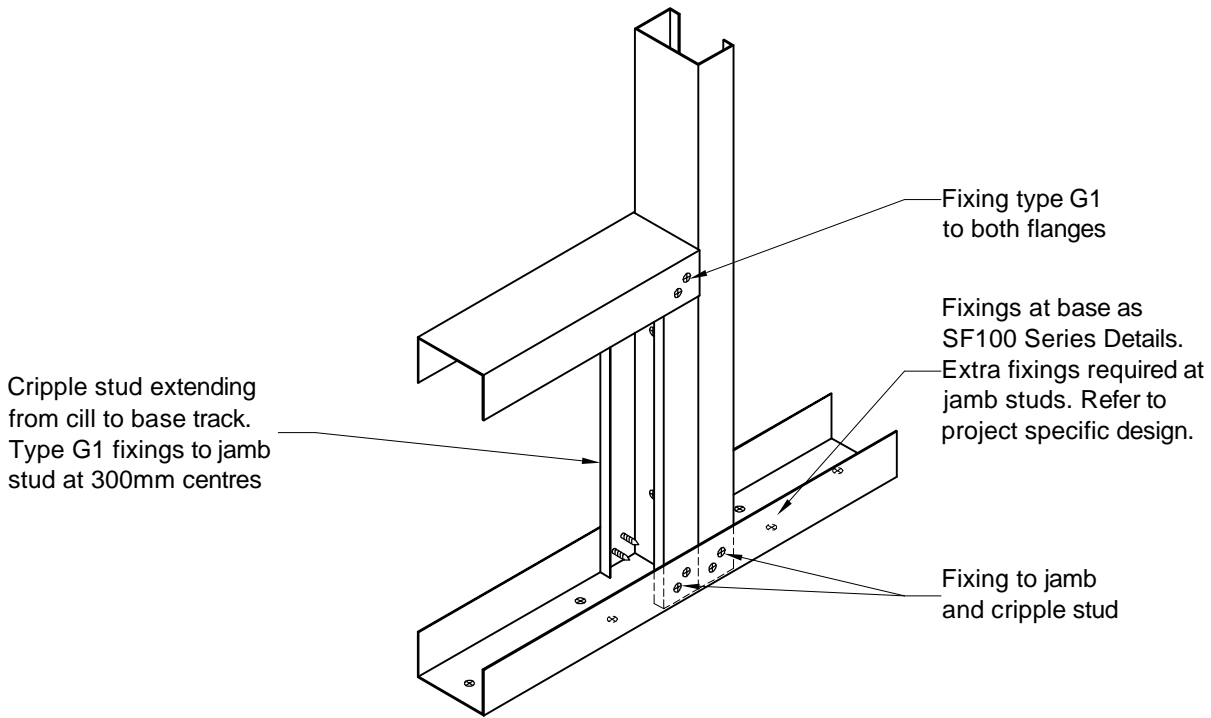

DETAIL SF445

High Load Base Detail - Single Jamb

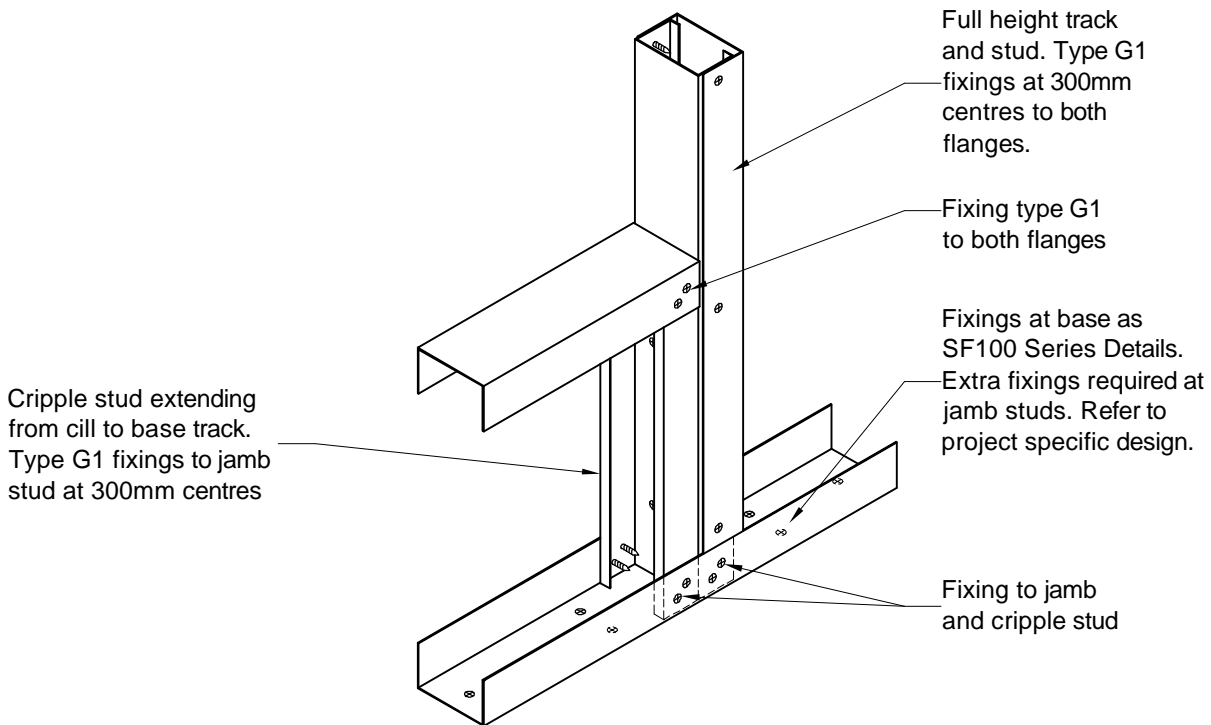

DETAIL SF445-2

High Load Base Detail - Two-Member Compound Jamb

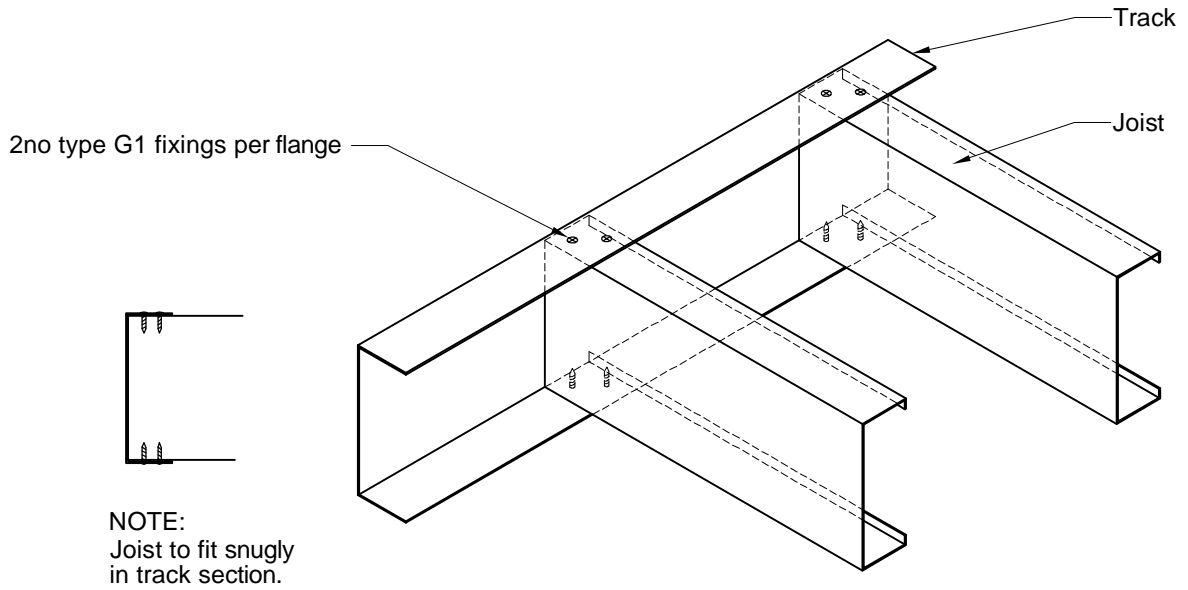

DETAIL SF610

Fixing Joists to Track: General Connection Detail

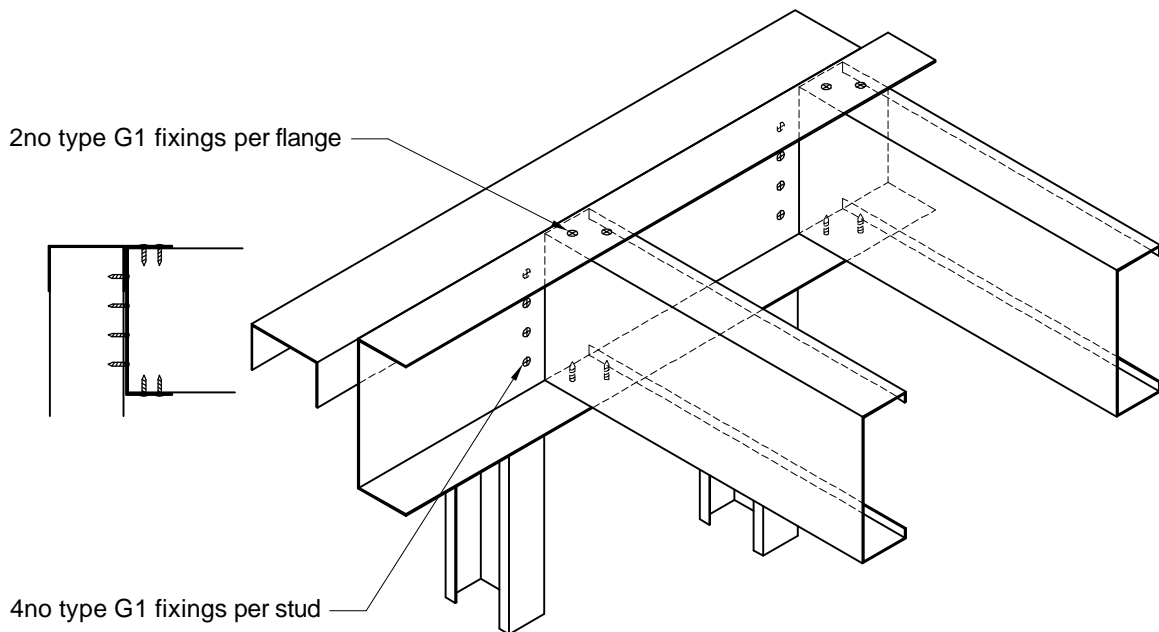

DETAIL SF611

Fixing Joists to Track: Side of Metsec Wall



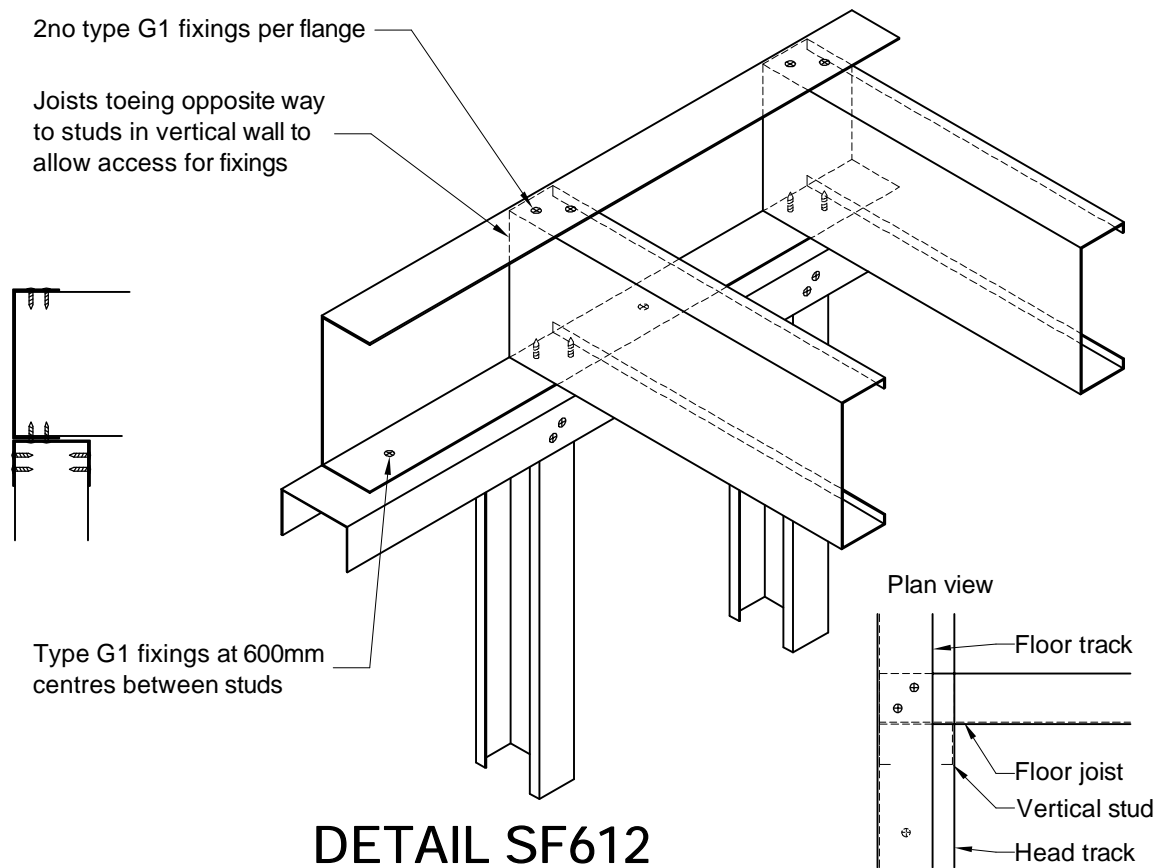

DETAIL SF612

Fixing Joists to Track: Top of Metsec Wall

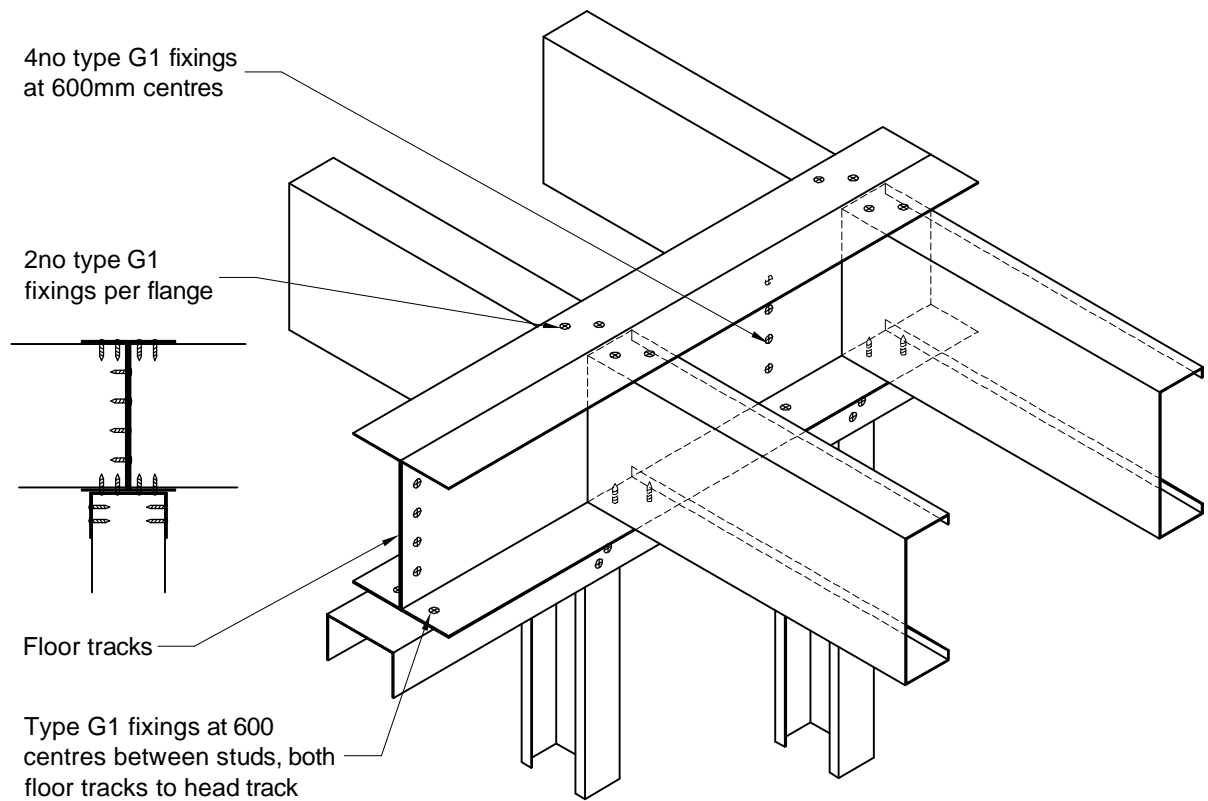

DETAIL SF613

Fixing Joists to Track: Central to Top of Metsec Wall



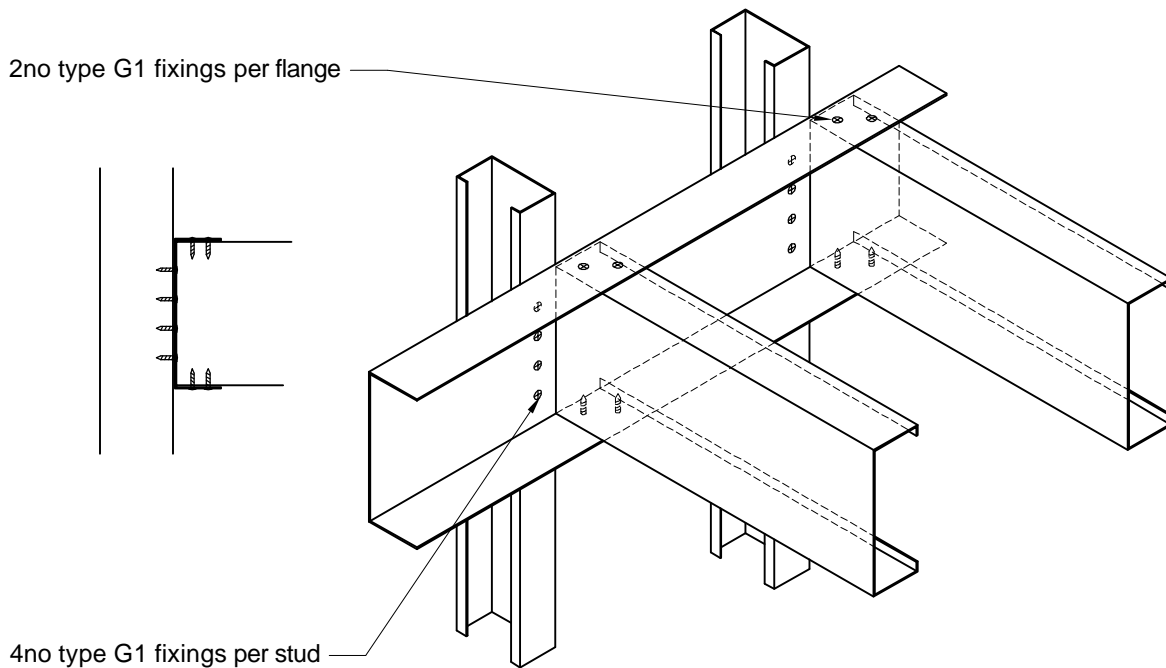

DETAIL SF614

Fixing Joists to Track: Middle of Metsec Wall

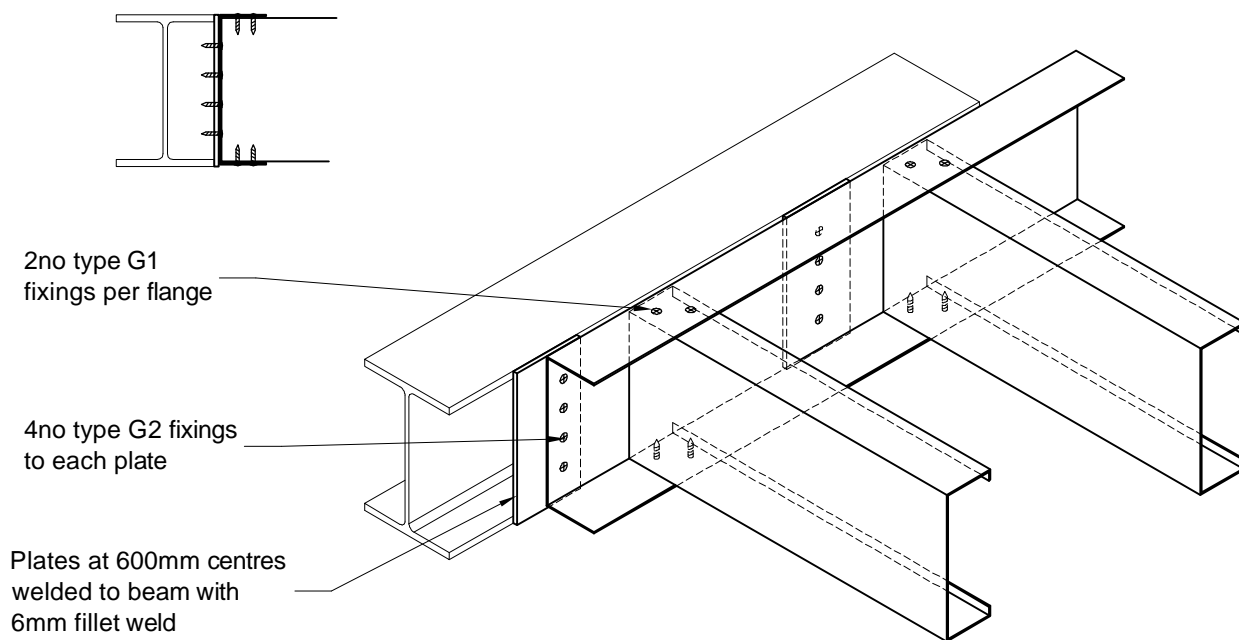

DETAIL SF615

Fixing Joists to Track: Hot Rolled Steel - Plates



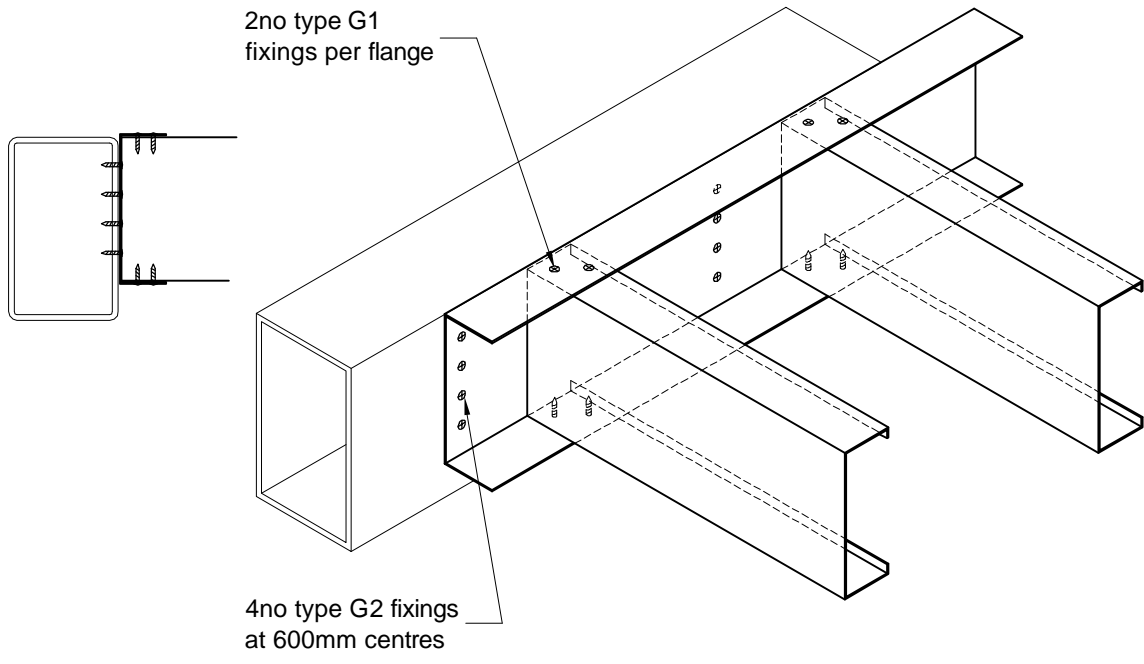

DETAIL SF616

Fixing Joists to Track: Hot Rolled Steel - Direct

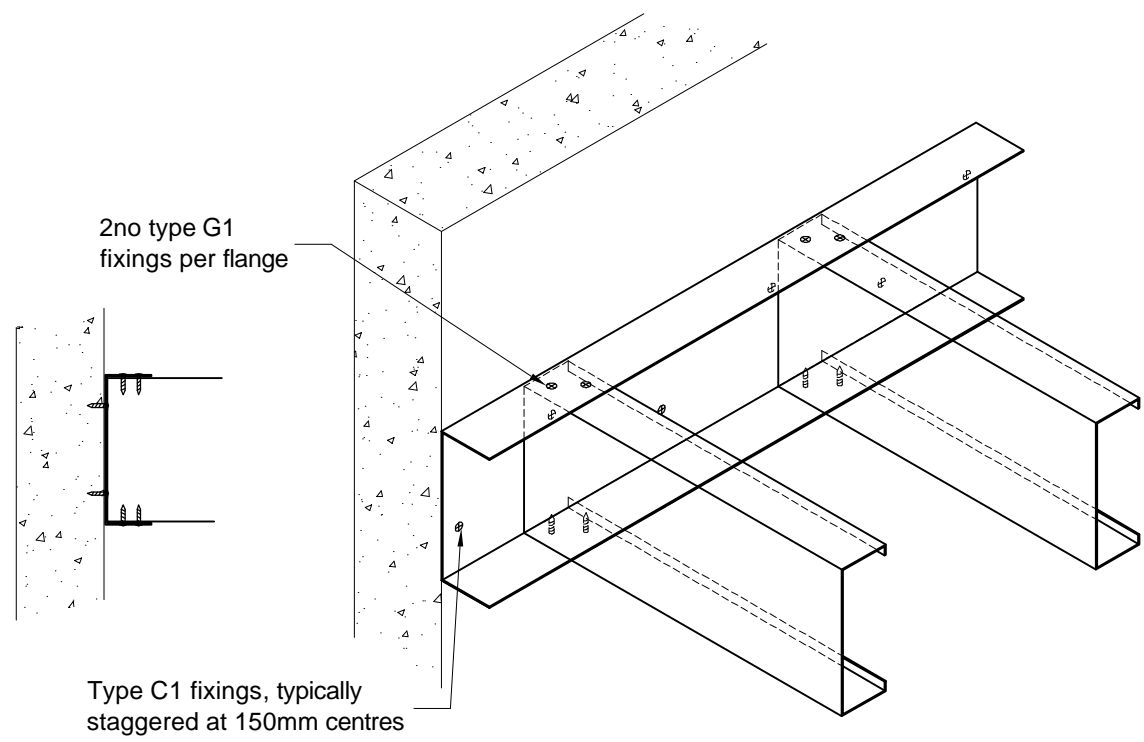

DETAIL SF617

Fixing Joists to Track: Concrete Wall



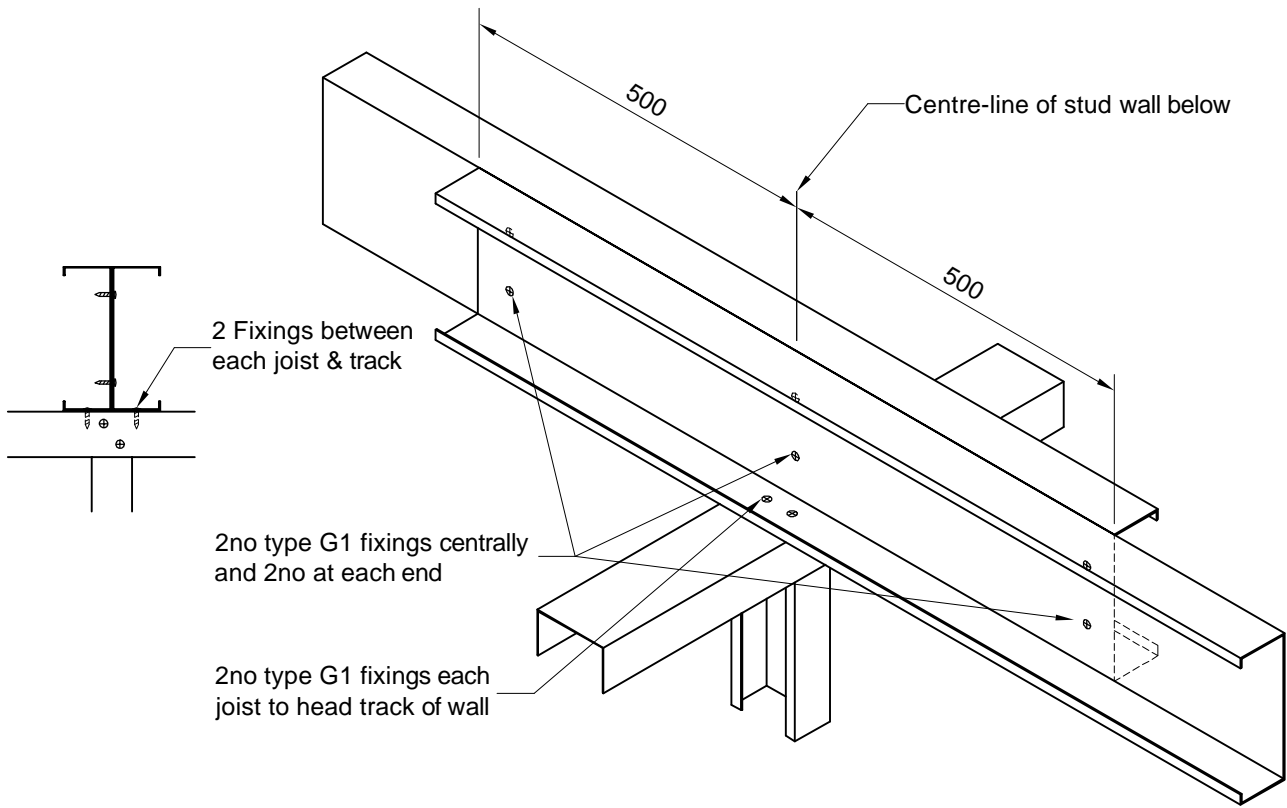

DETAIL SF621

Joisted Floor / Roof: Joists Lapped Over Support

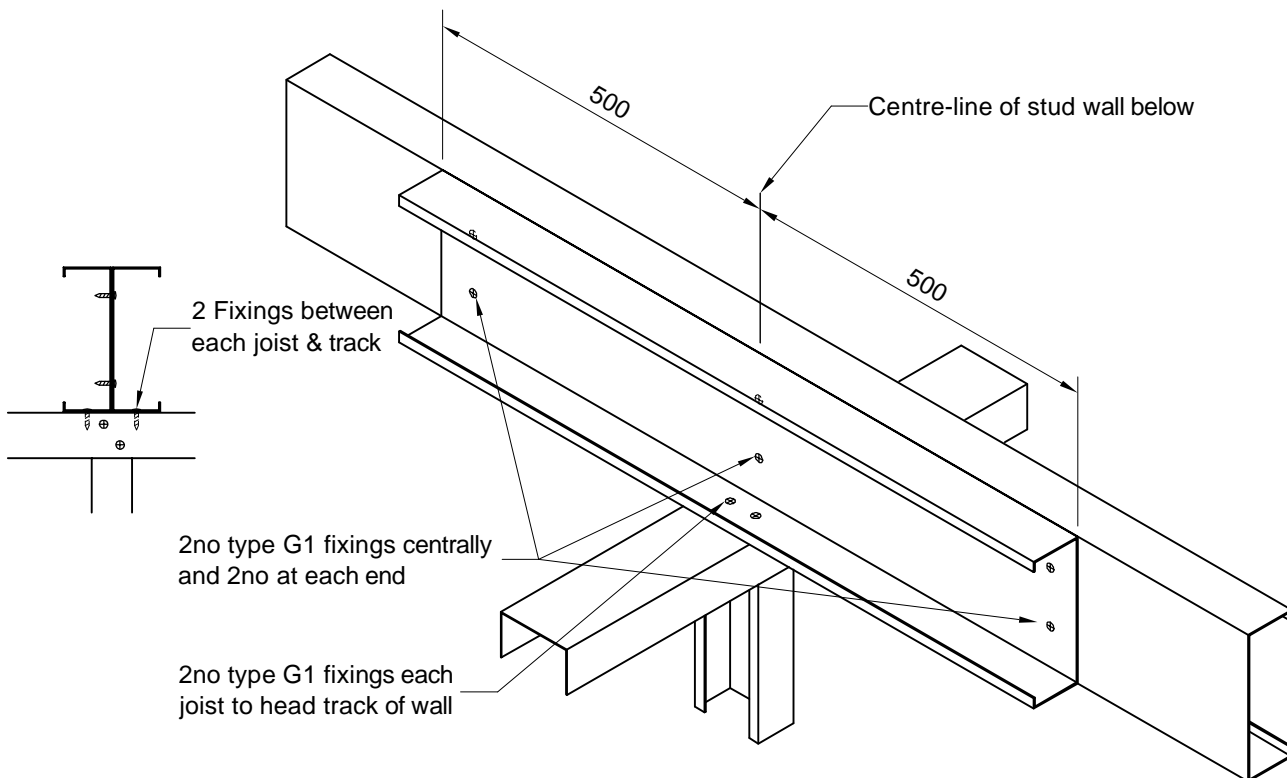

DETAIL SF622

Joisted Floor / Roof: Joists Strengthened at Support



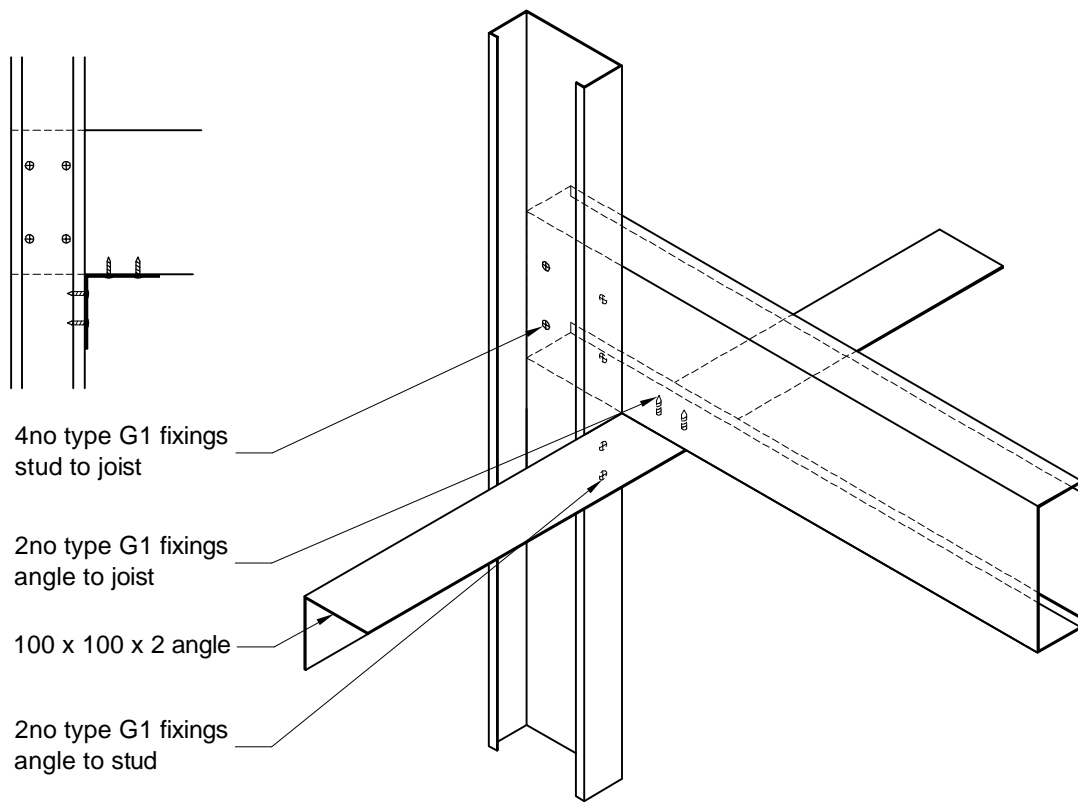

DETAIL SF623

Joisted Floor / Roof: Joist Fixed to Middle of Metsec Wall

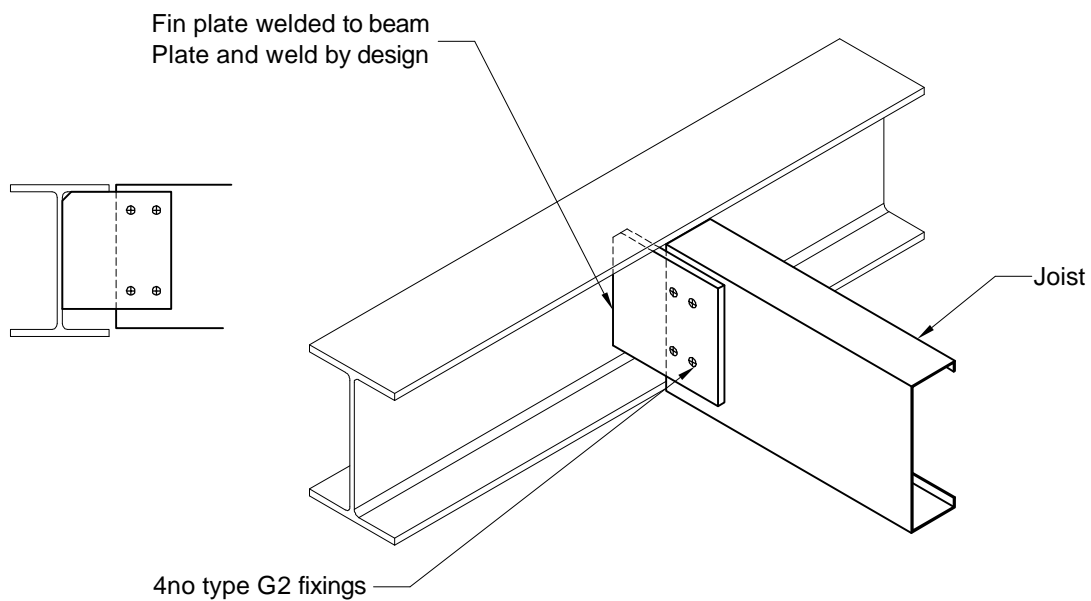

DETAIL SF624

Joisted Floor / Roof: Joist Fin-plated to Hot Rolled Steel



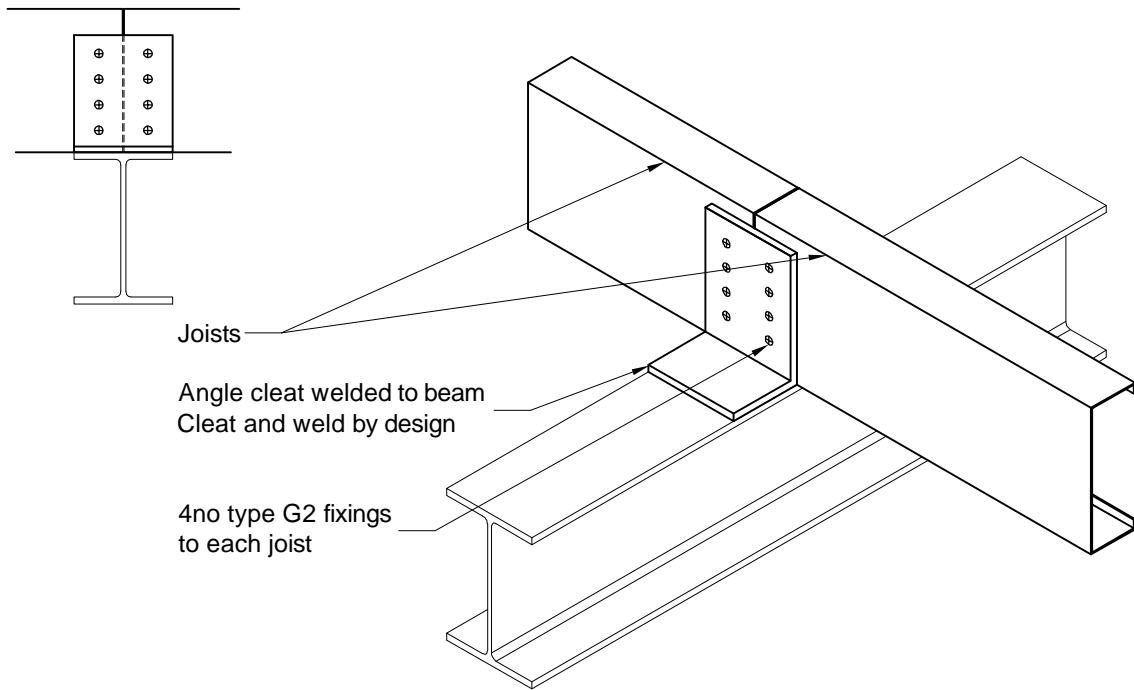

DETAIL SF625

Joisted Floor / Roof: Joist Cleated to Hot Rolled Steel

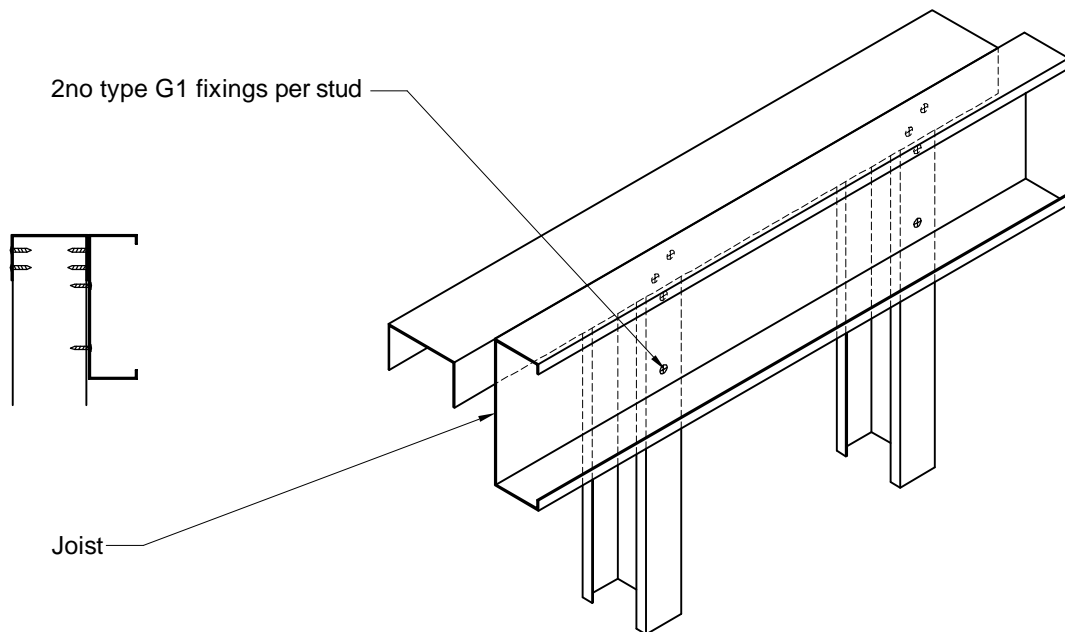

DETAIL SF631

Joisted Floor / Roof: Joist Connection to Side of Metsec Wall



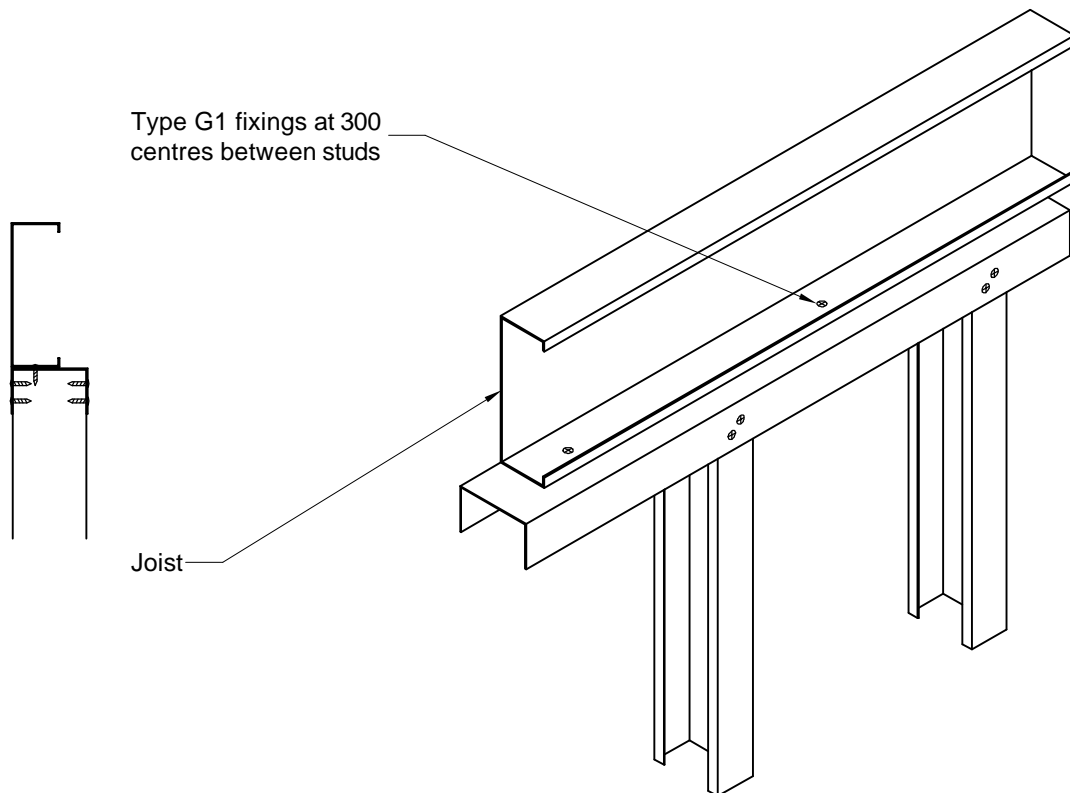

DETAIL SF632

Joisted Floor / Roof: Joist Connection to Top of Metsec Wall

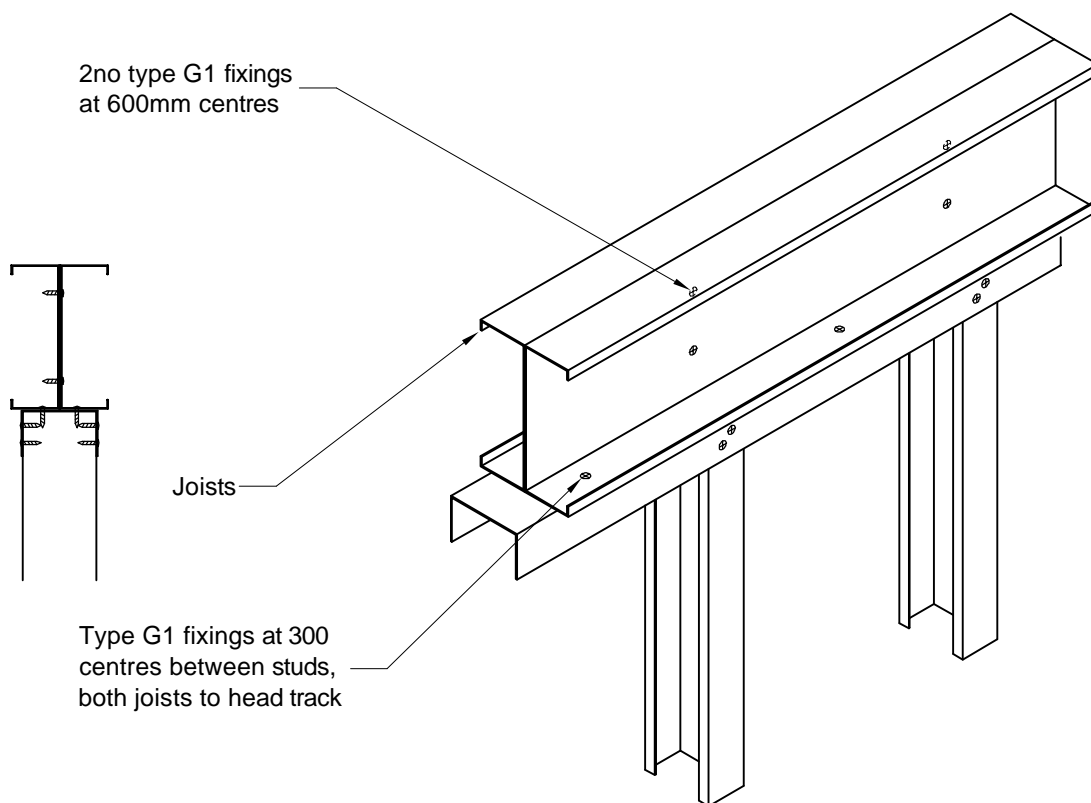

DETAIL SF633

Joisted Floor / Roof: Joist Connection Central to Top of Metsec Wall



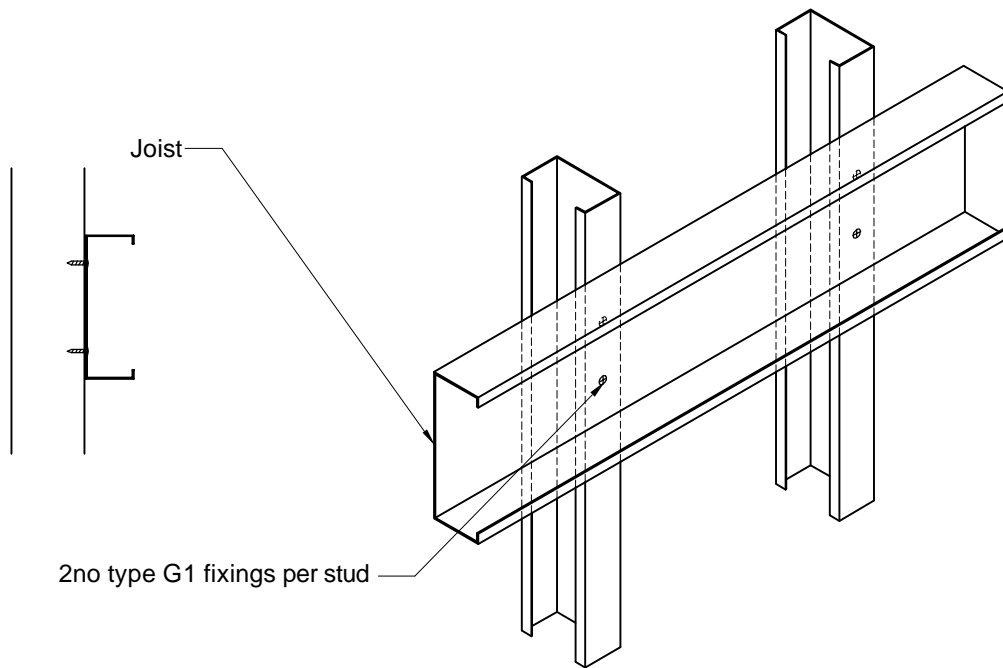

DETAIL SF634

Joisted Floor / Roof: Joist Connection to Stud

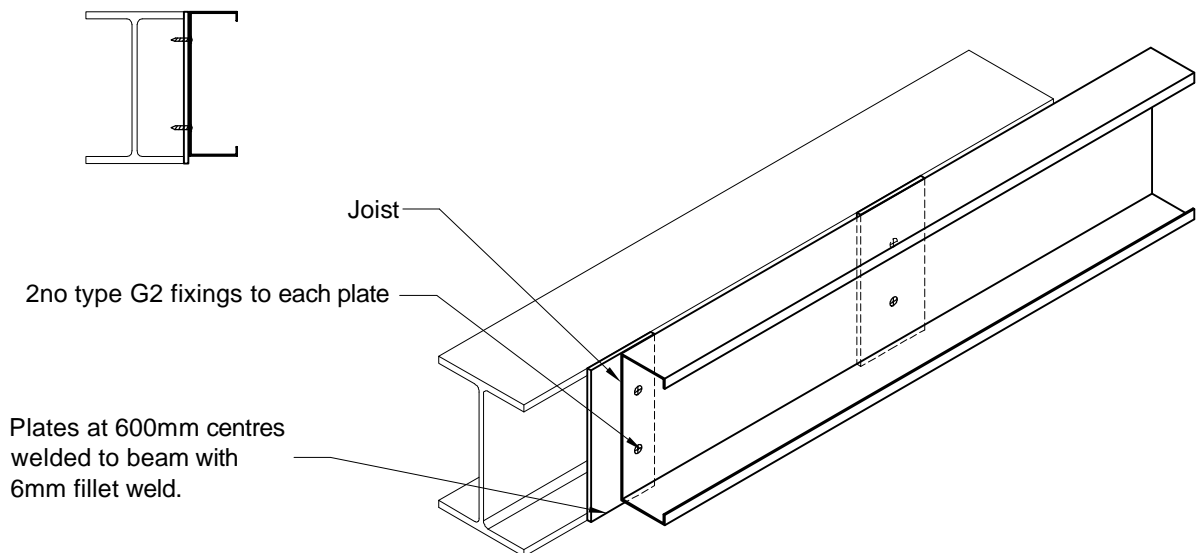

DETAIL SF635

Joisted Floor / Roof: Joist Connection to Hot Rolled Steel - Plates



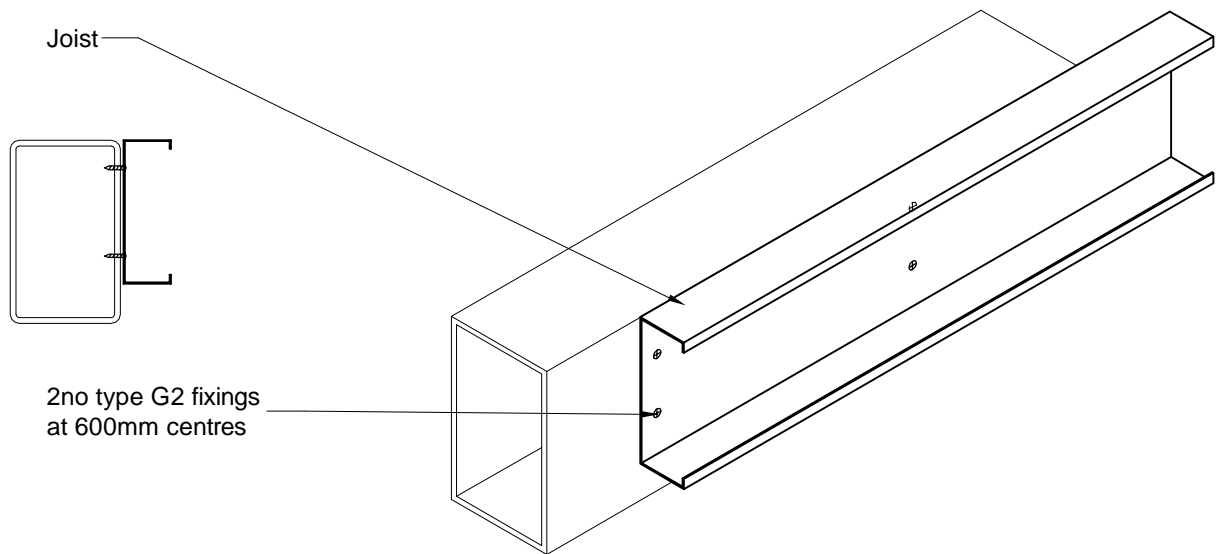

DETAIL SF636

Joisted Floor / Roof: Joist Connection to Hot Rolled Steel - Direct

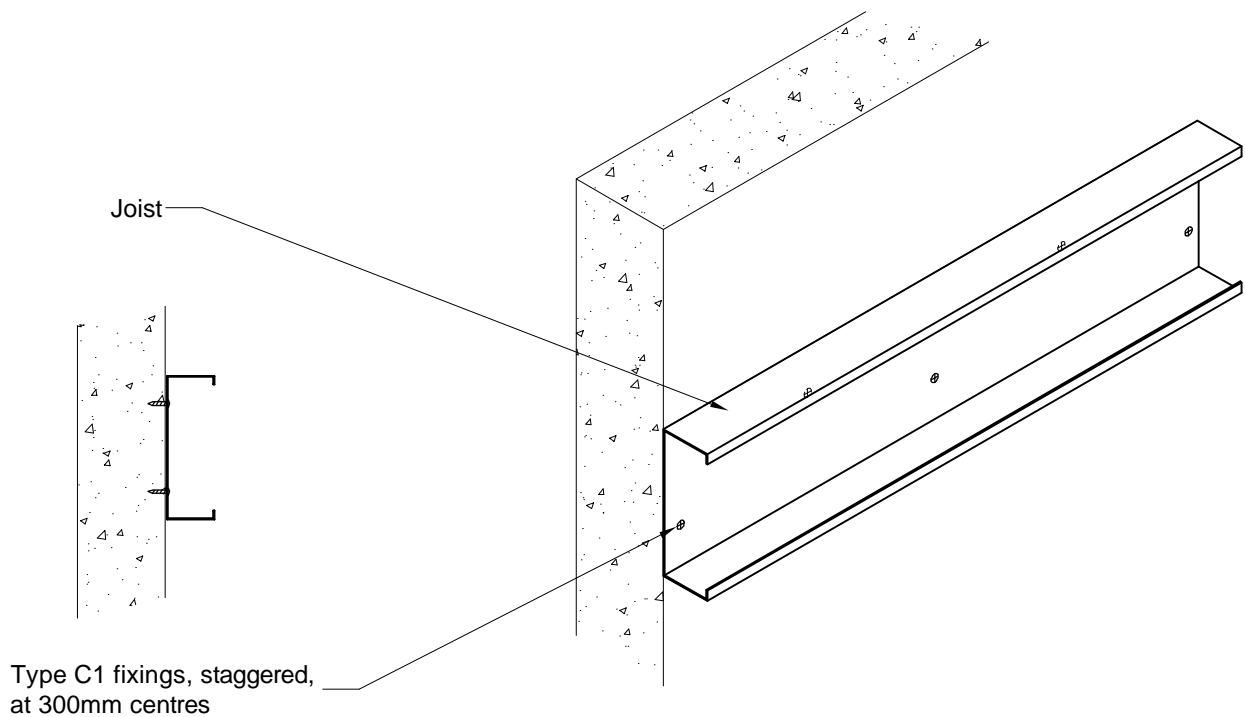

DETAIL SF637

Joisted Floor / Roof: Joist Connection to Concrete Wall

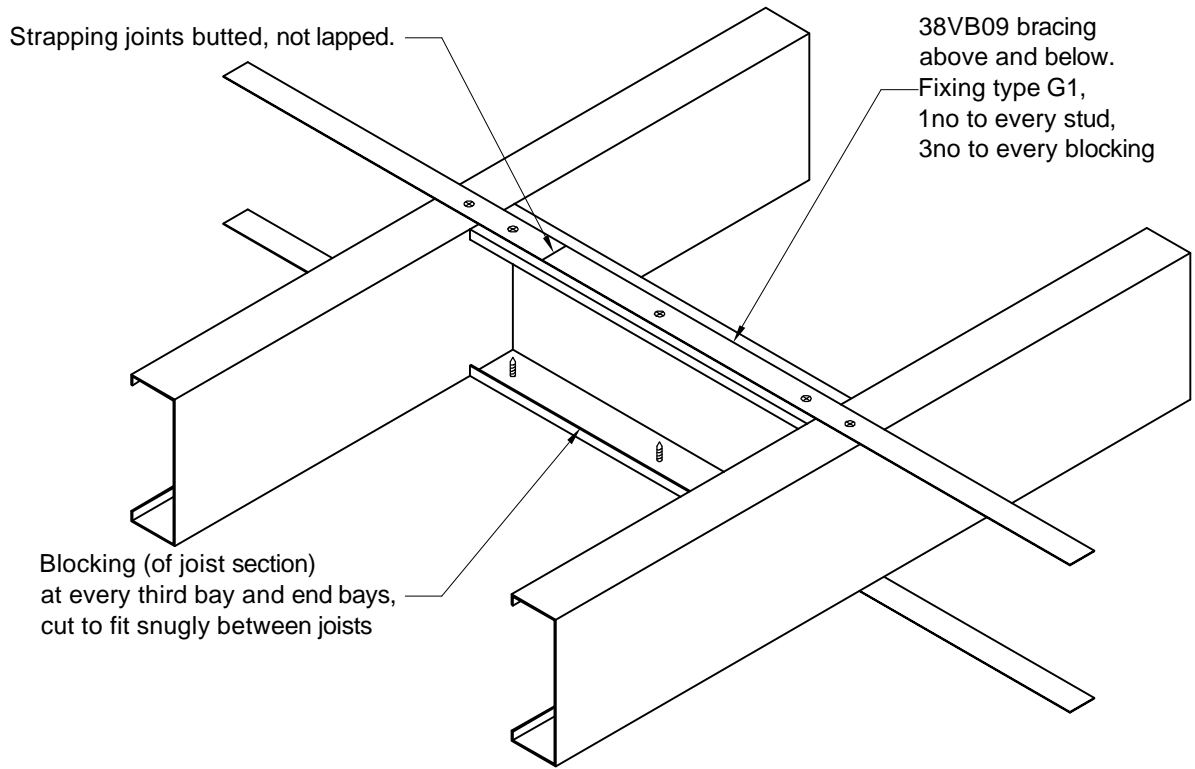

DETAIL SF641

Joisted Floor / Roof: Restraint Blocking

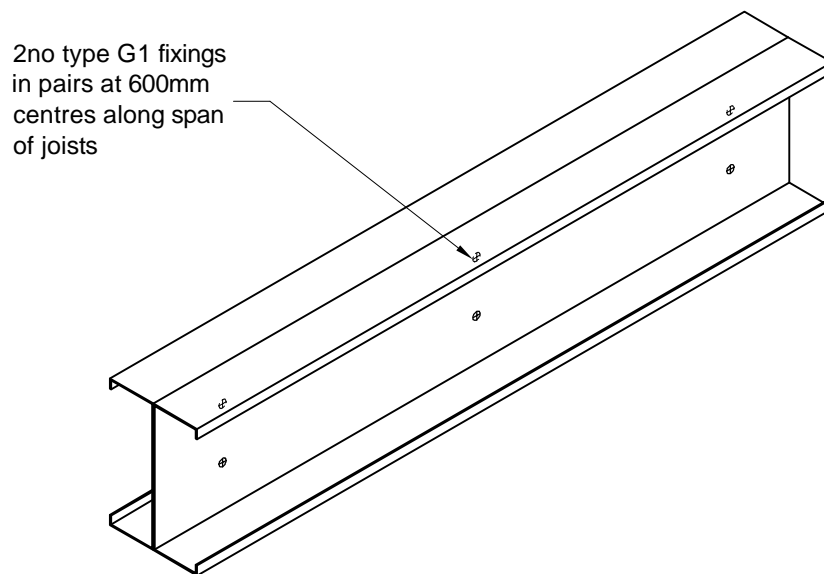

DETAIL SF644

Joisted Floor / Roof: Back-to-back Joists

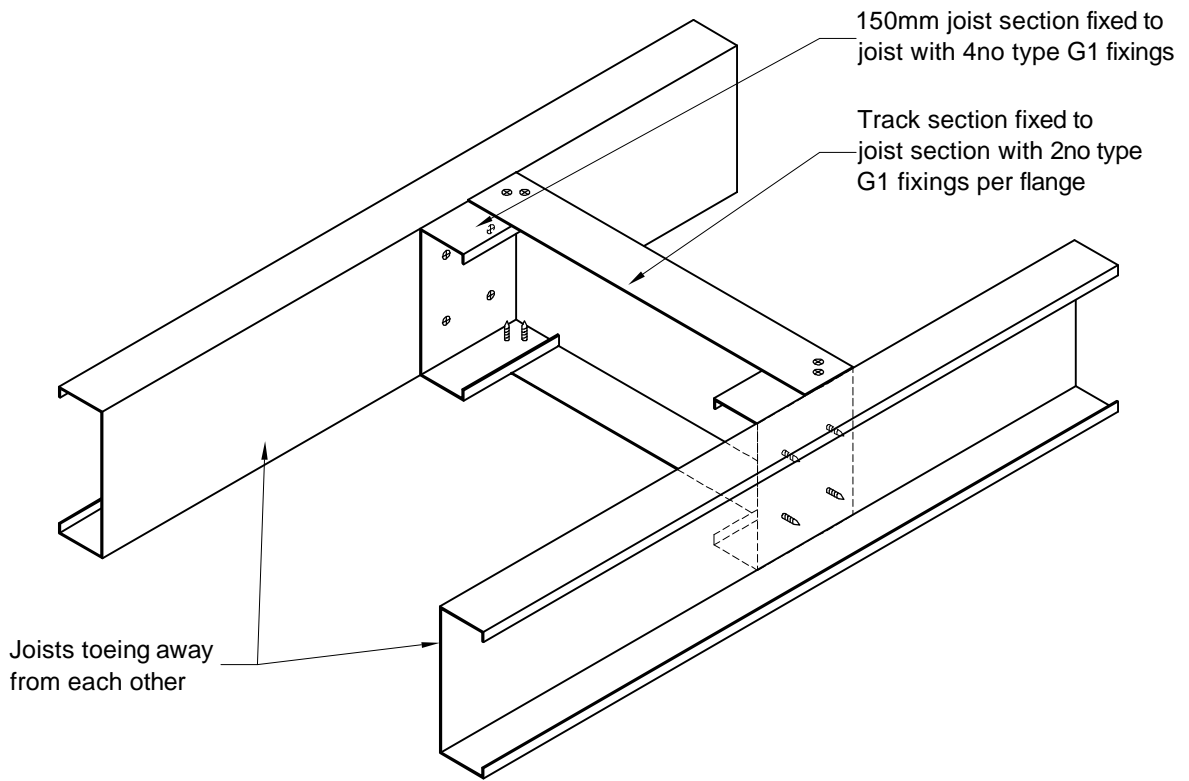

DETAIL SF645

Joisted Floor / Roof: Standard Trimmer Detail

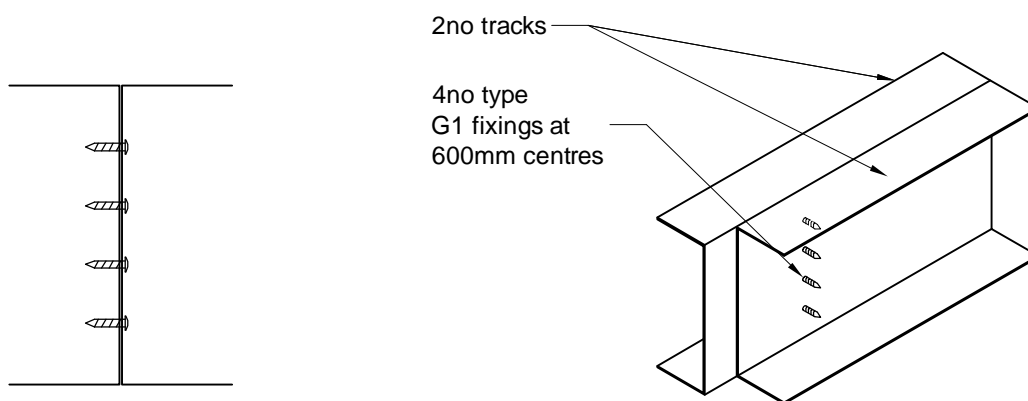

DETAIL SF651

Back-to-back Track Beam



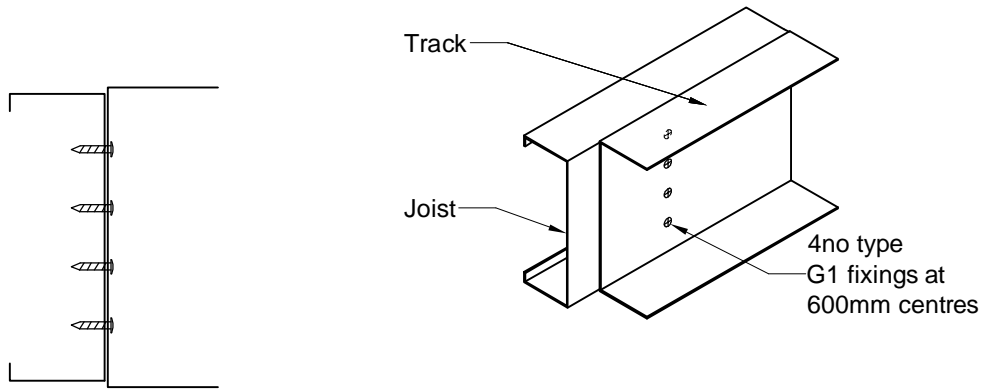

DETAIL SF652

Track and Joist Beam

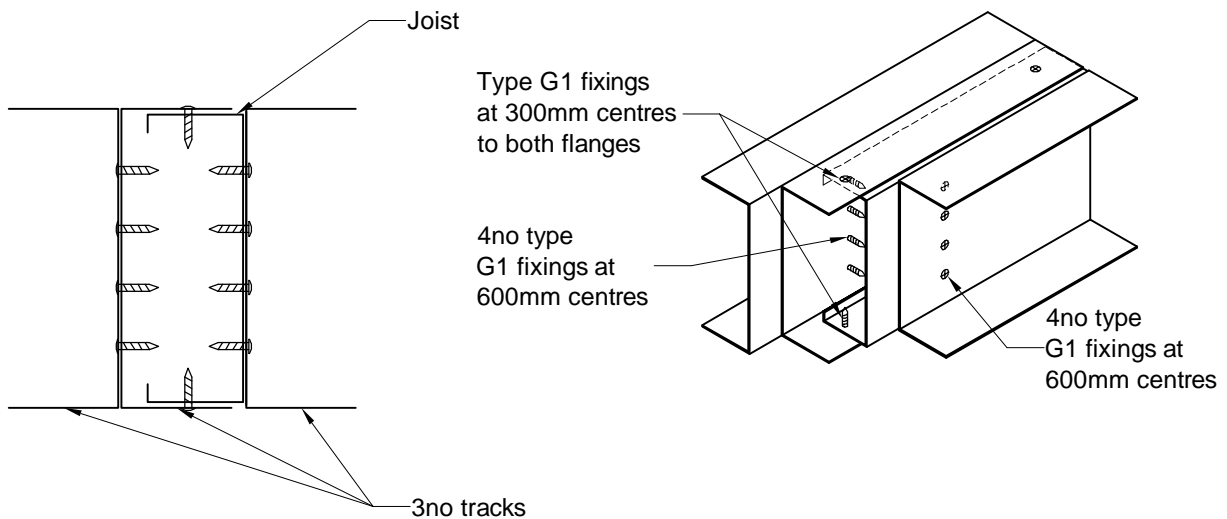

DETAIL SF653

Compound Back-to-back Track Beam



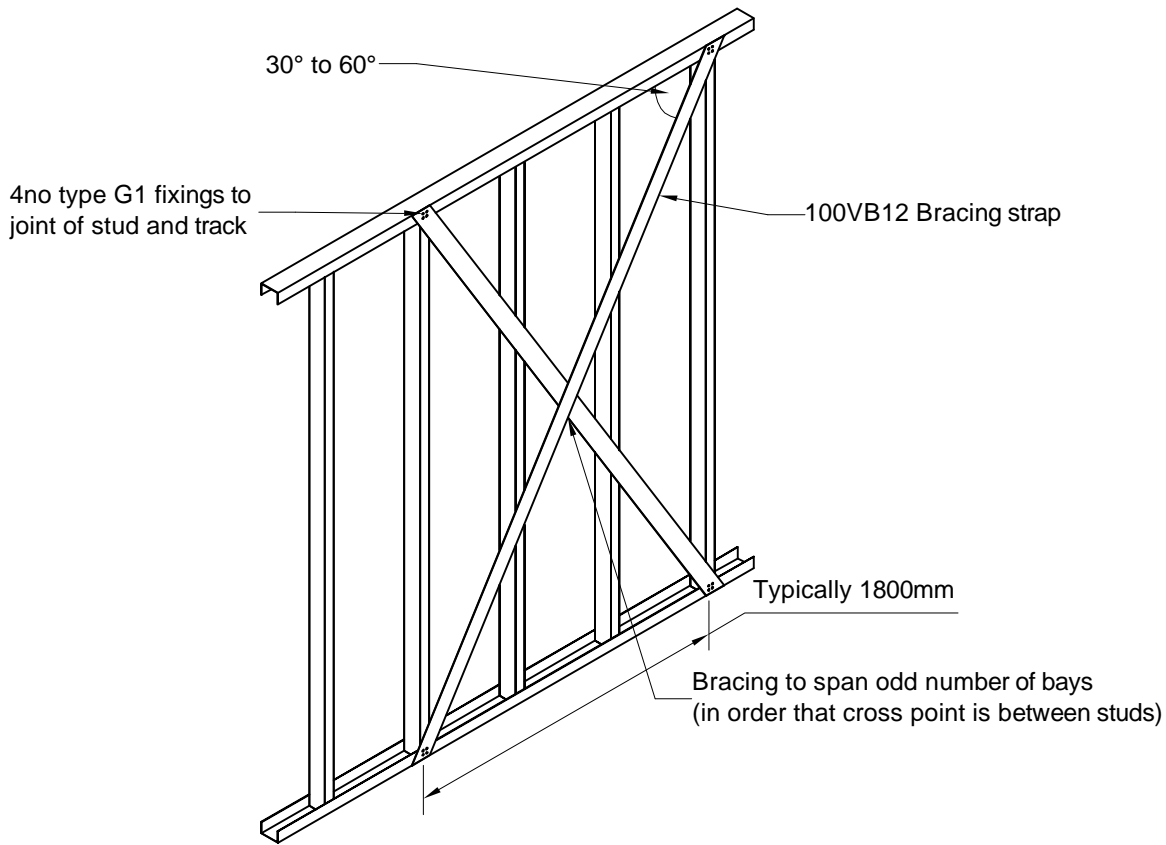

DETAIL SF711

Typical Bracing Setout for Walls

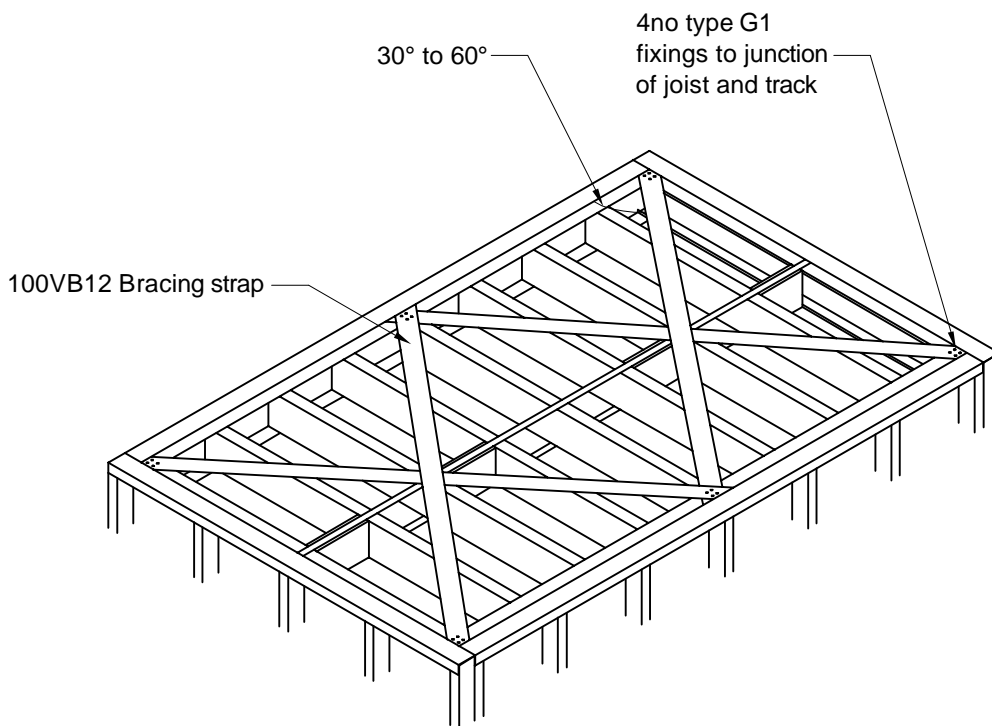

DETAIL SF712

Typical Bracing Setout for Floors

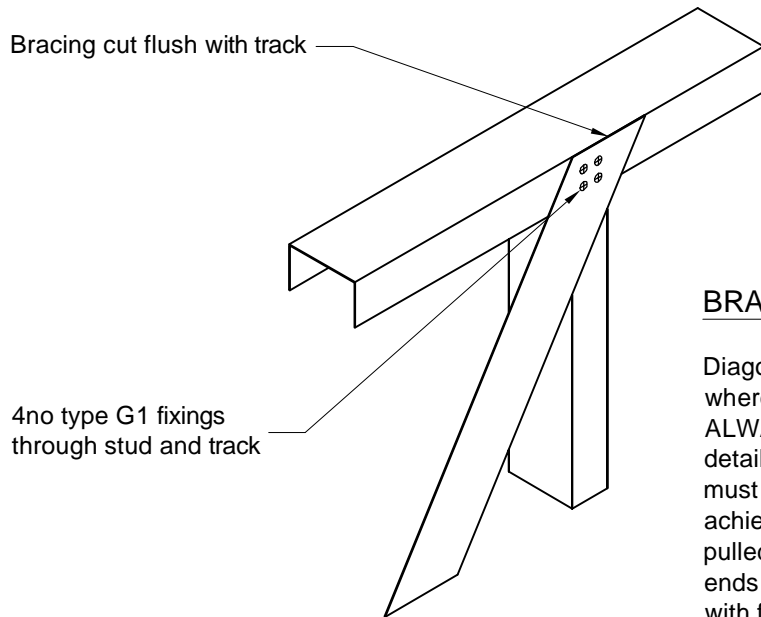

BRACING IMPORTANT NOTES

Diagonal strap bracing is fitted to walls / floors where shown on the Metsec drawings. Straps ALWAYS connect to stud / track junctions. Screw details as shown above. Diagonal strap bracing must be installed TIGHT. Use clamps or levers to achieve this - but check that the wall / floor is not pulled out of square. Protruding corners of strap ends are to be removed with snips to finish flush with frame ends.

DETAIL SF713

Bracing Connections

6no type G1 fixings equally positioned (10mm Min edge distance)

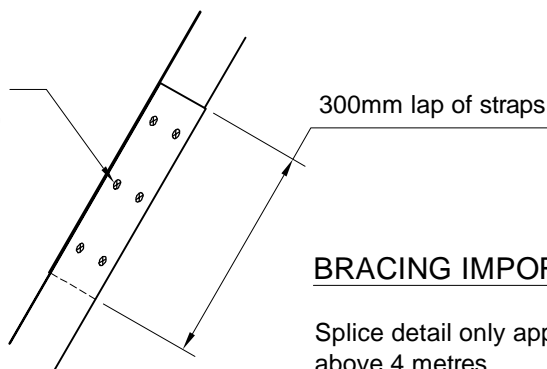

BRACING IMPORTANT NOTE

Splice detail only applies when brace length is above 4 metres.

DETAIL SF714

Bracing Splice



2no type G1 fixings per flange

Type G1 fixings at typical 300 centres. Alternate screws staggered at 50mm cross-centres

4no type G1 fixings per stud

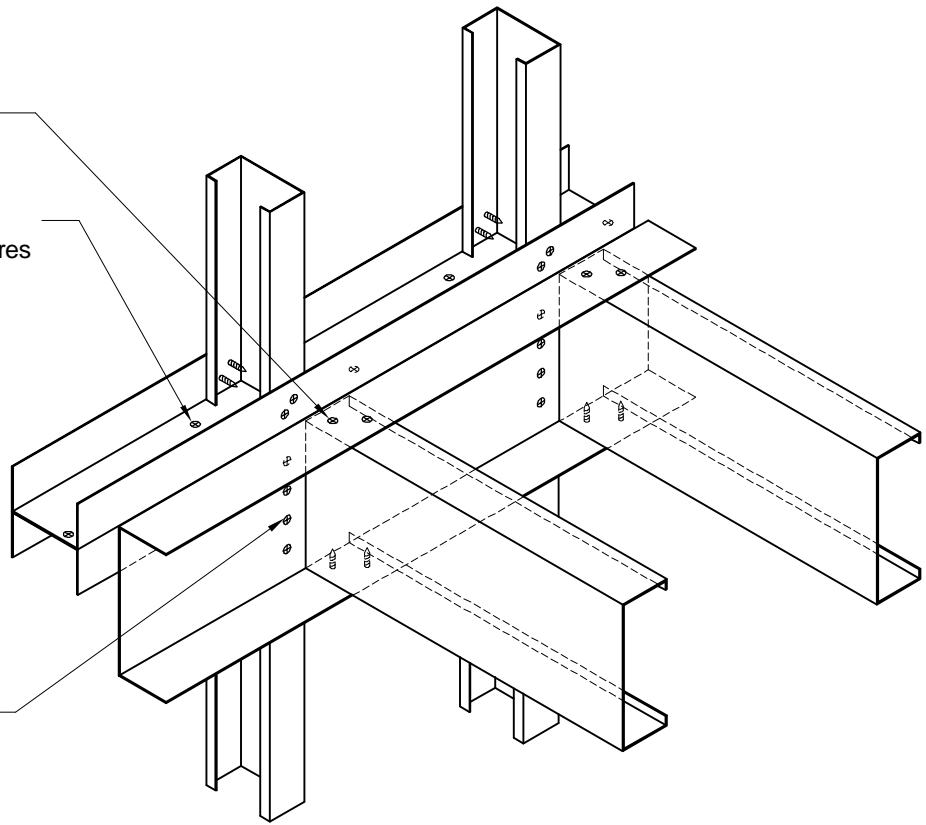
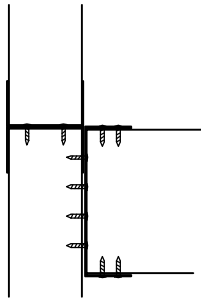

DETAIL SF721

Disproportionate Collapse: Wall Connection - Wall on Wall Below

Length of stud section to match joist depth fixed to joist web with 4no type G1 fixings. Stud orientation and alignment as wall studs

Type G1 fixings at 300mm centres

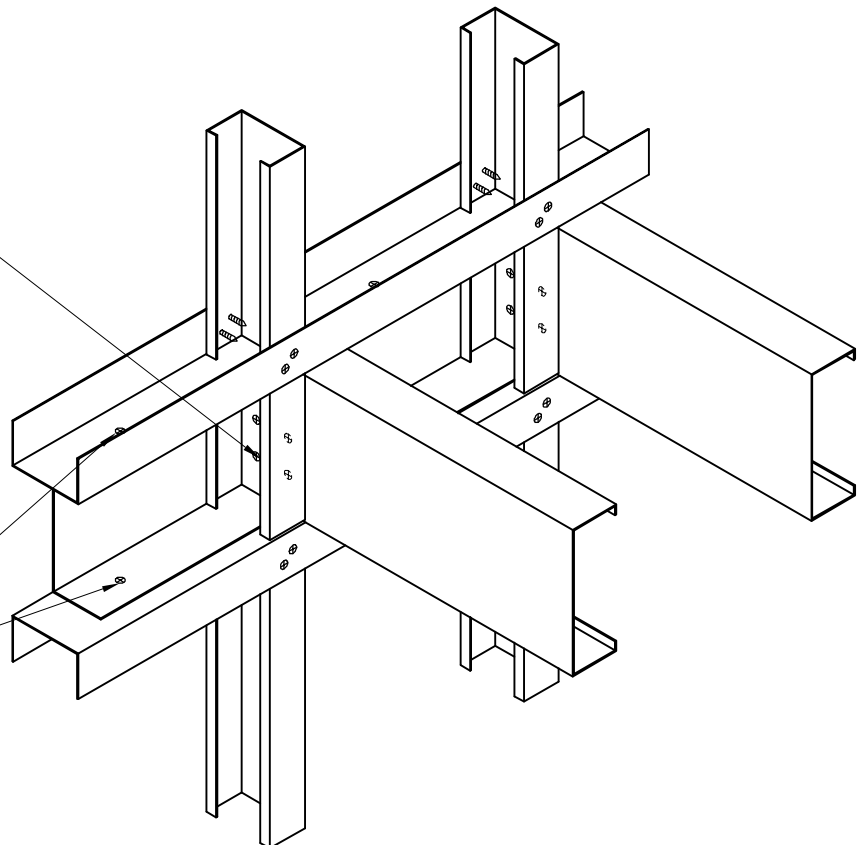
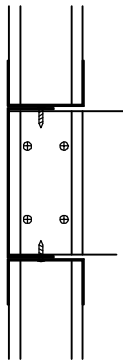

DETAIL SF722

Disproportionate Collapse: Wall Connection - Wall on Joist Track



Type G1 fixings
at 600mm centres

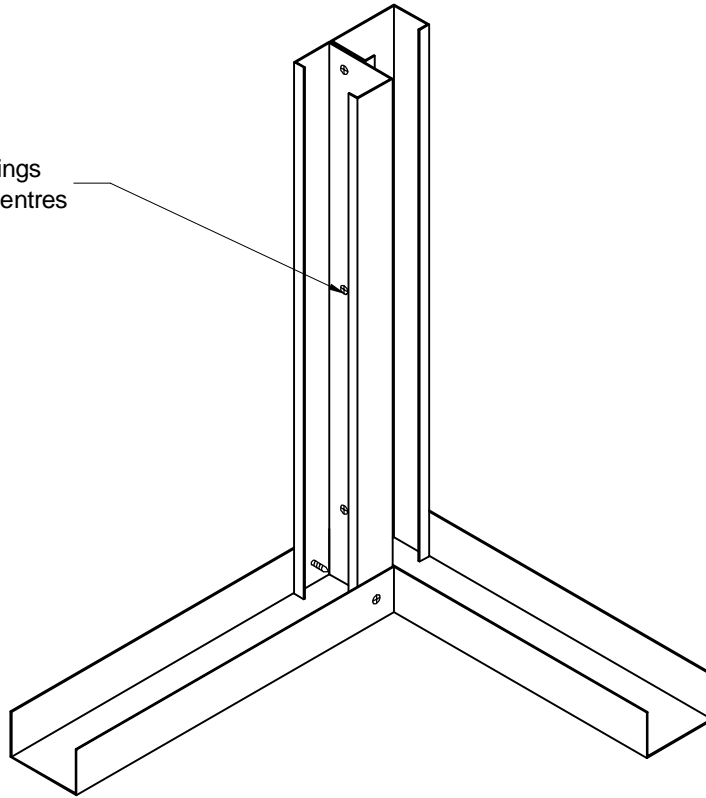

DETAIL SF723

Disproportionate Collapse: Wall Connection At Junction

2no type G1
fixings per flange

4no type G1 fixings
at 600mm centres

Sloping tracks

Sloping track

Type G1 fixings at 600
centres between studs, both
floor tracks to head track

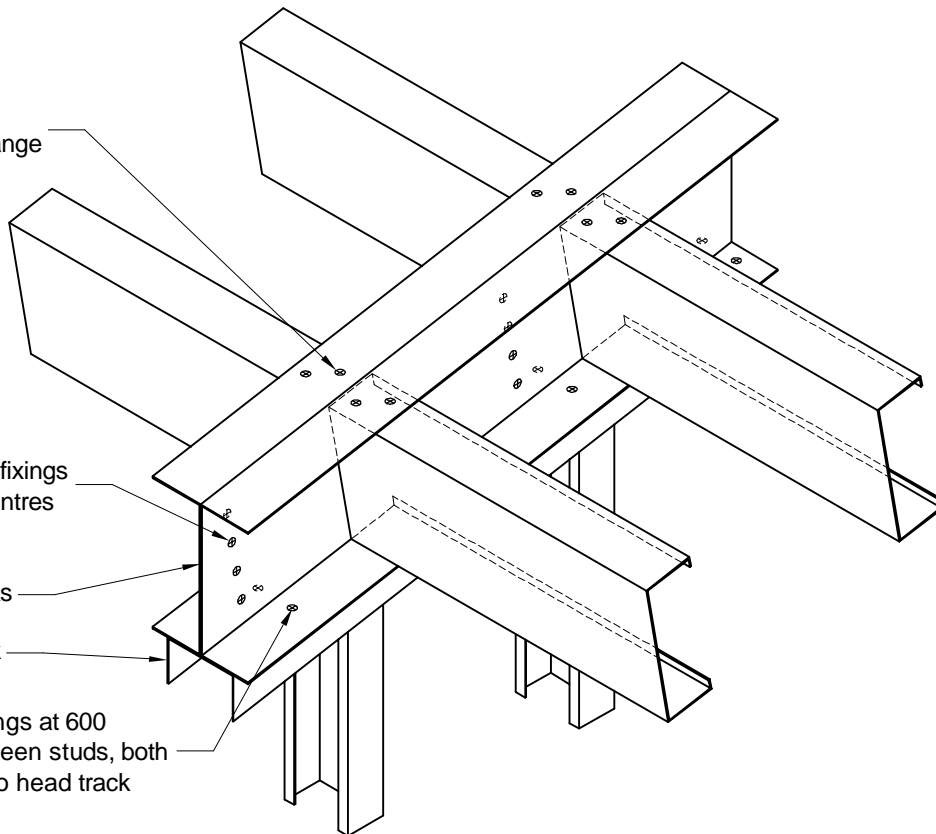

DETAIL SF731

Alternate Roof Details: Sloped Metsec Roof



SFS Load Bearing Installation Guide Section 5
© Copyright METSEC plc 2009
Tel: 0121 601 6000 Fax: 0121 601 6126

voestalpine

ONE STEP AHEAD.

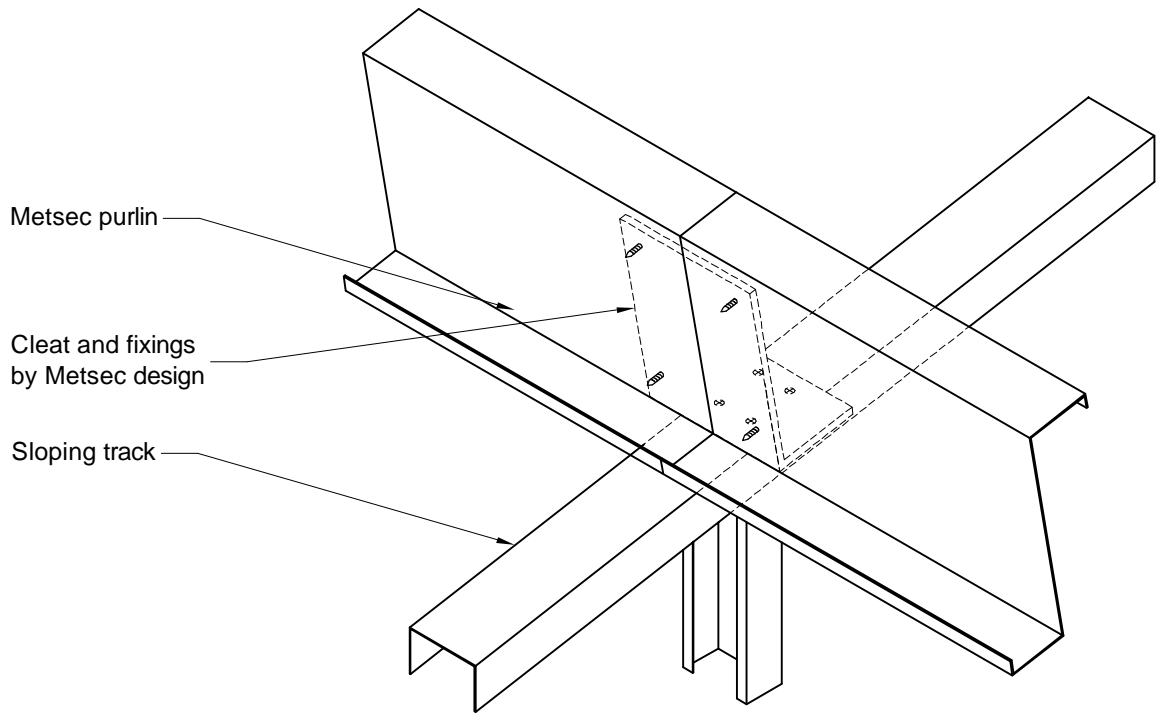

Metsec purlin

Cleat and fixings
by Metsec design

Sloping track

DETAIL SF732

Alternate Roof Details: Sloped Purlin Roof

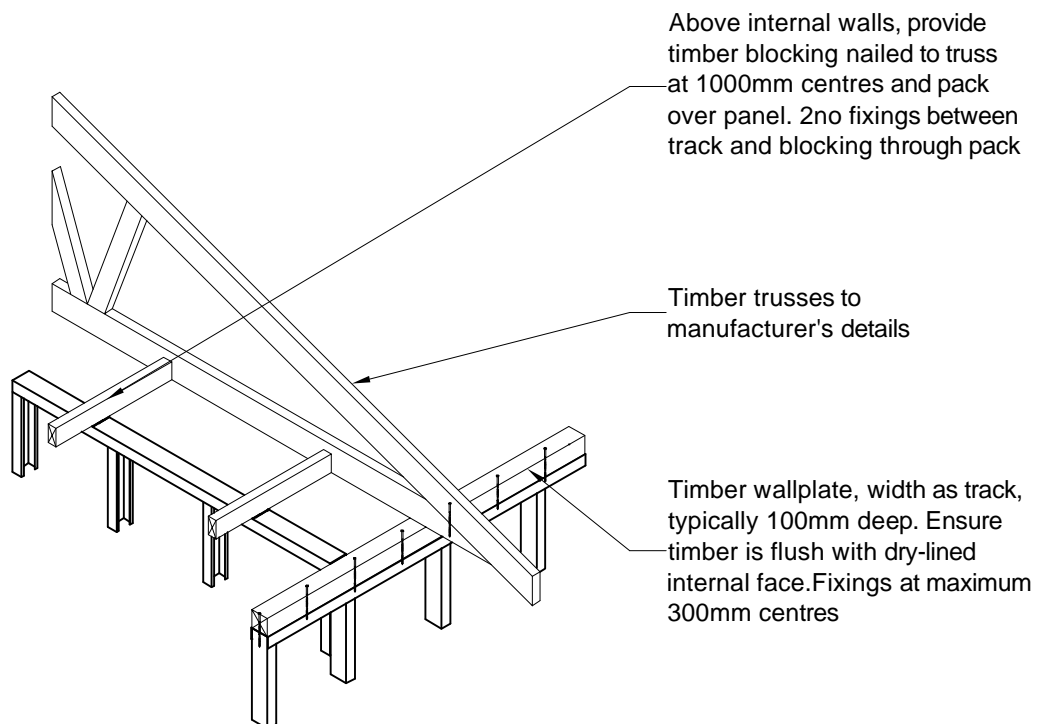

Above internal walls, provide
timber blocking nailed to truss
at 1000mm centres and pack
over panel. 2no fixings between
track and blocking through pack

Timber trusses to
manufacturer's details

Timber wallplate, width as track,
typically 100mm deep. Ensure
timber is flush with dry-lined
internal face. Fixings at maximum
300mm centres

DETAIL SF733

Alternate Roof Details: Timber Truss Roof



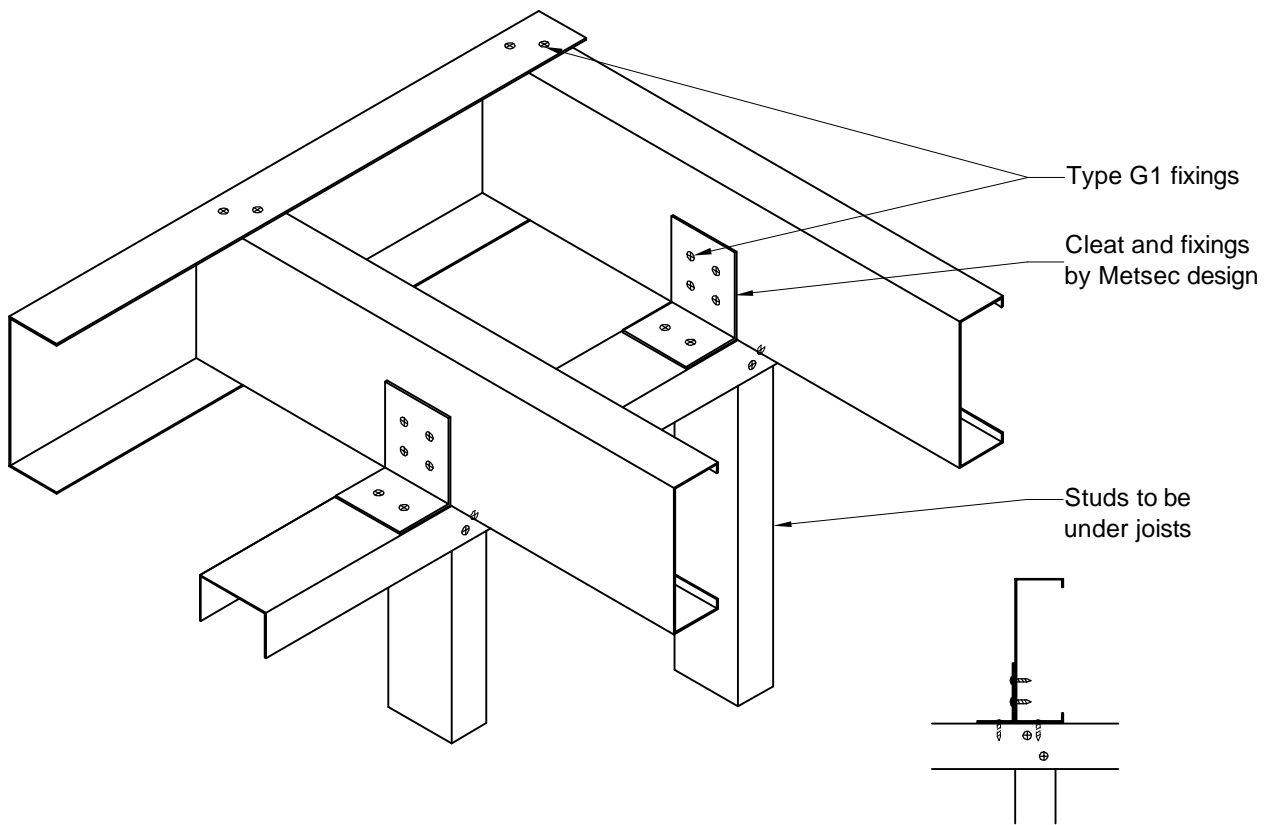

DETAIL SF734

Alternate Roof Details: Roof Overhang Cantilevered Joist

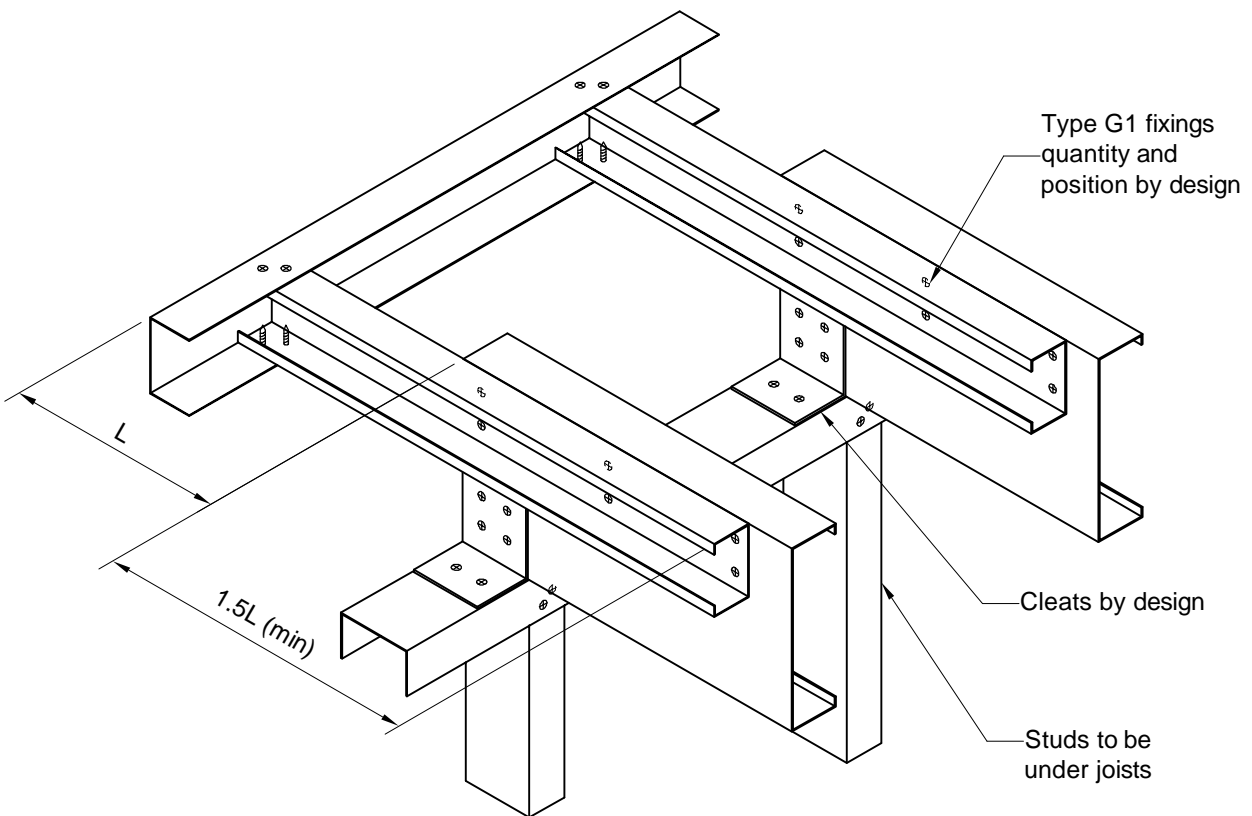

DETAIL SF735

Alternate Roof Details: Roof Overhang Shallow Projection



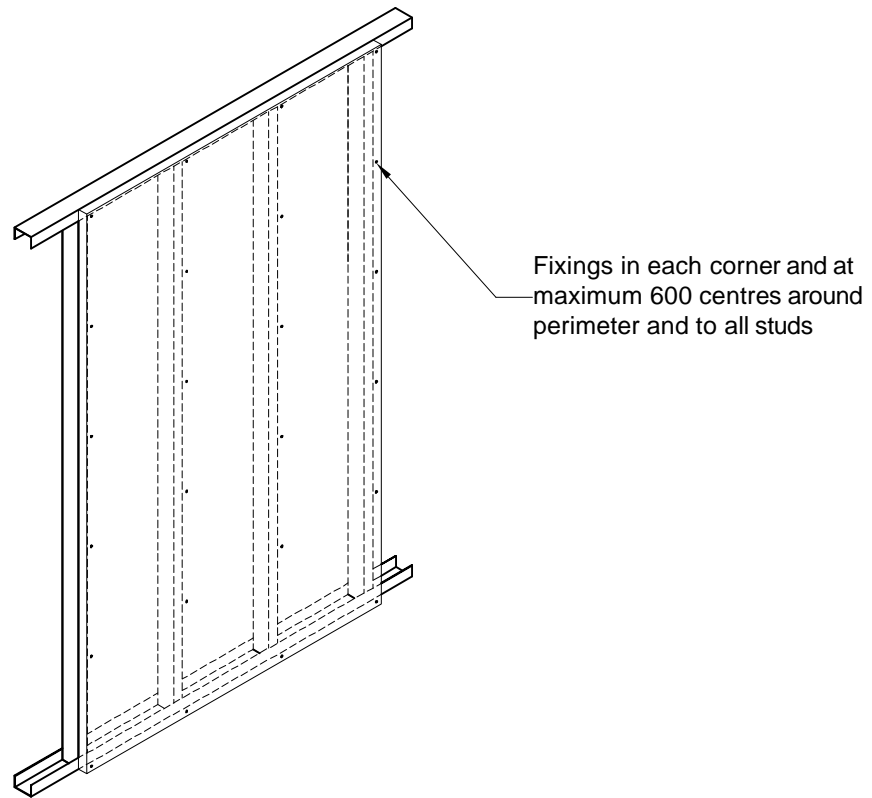

Fixings in each corner and at maximum 600 centres around perimeter and to all studs

DETAIL SF811-1

Fixing Rigid Insulation to Load-bearing

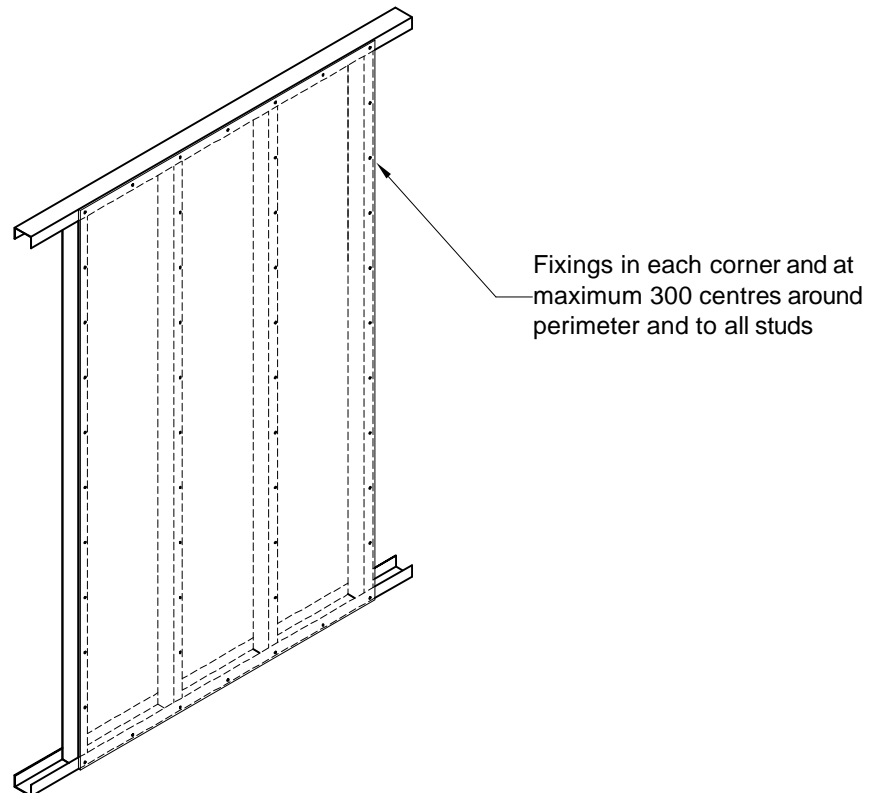

Fixings in each corner and at maximum 300 centres around perimeter and to all studs

DETAIL SF813-1

Fixing Boarding - (CPB, OSB, PLY) to Load-bearing



SFS Load Bearing Installation Guide Section 6
 © Copyright METSEC plc 2009
 Tel: 0121 601 6000 Fax: 0121 601 6126

voestalpine

ONE STEP AHEAD.

Fixings at 300mm centres
around perimeter and
to all studs & strap

100VB12 strap for
fixing edge of board
to between studs

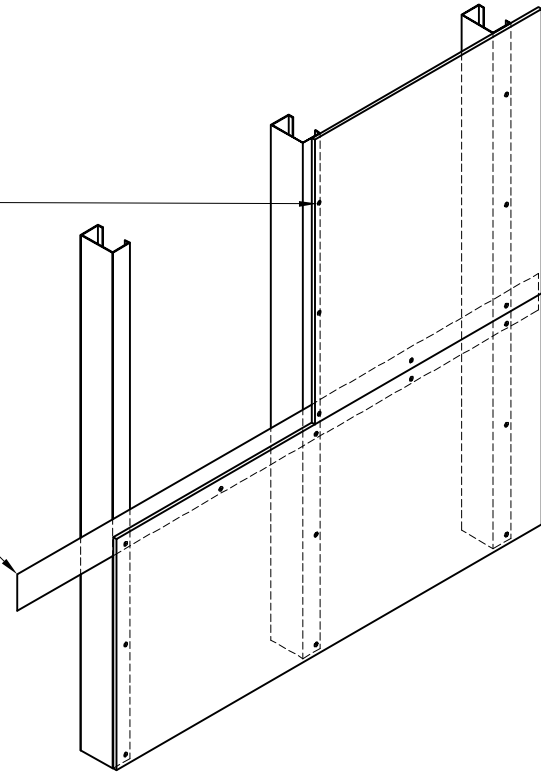

DETAIL SF815

Horizontal Board Joint

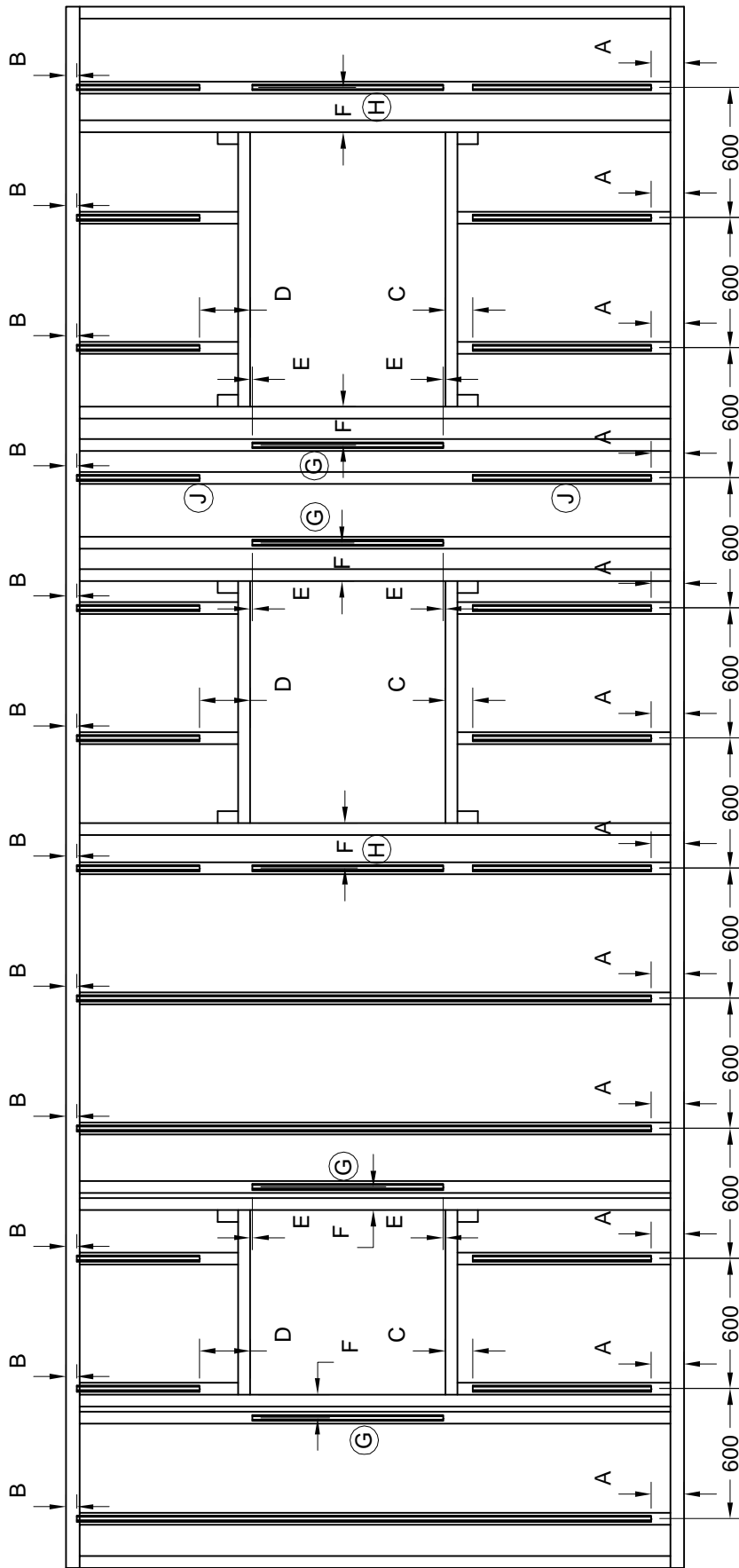

DETAIL SF821

Typical Arrangement of Brick Tie Channels

A = 150mm, u/s basetrack to bottom of brick tie channel (btc).
 B = 50mm, top of btc to top of panel.
 C = 125mm, Metsec cill to top of btc below.
 D = 235mm, Metsec lintel to bottom of btc over.
 E = 10mm, Metsec cill/lintel to bic adjacent window.
 F = 70-215mm, brickwork reveal to btc - see detail SF823.

⊙ = Additional btc required where btc's at 600mm centres do not satisfy dimension F.
 (H) = Detail where btc's at 600mm centres satisfy dimension F.
 (J) = Where btc's between windows are at less than 600mm centres any btc's falling between do not need to be full height.

Notes:

1. All btc dimensions are to centreline of channel
2. These rules must be read in conjunction with architect's project-specific opening setout/drawings.
3. Btc's fixed to studs with stand-off screws at 450mm vertical centres. Minimum 2no screws per panel.
4. Brick ties to be built into brickwork at 450mm vertical centres.

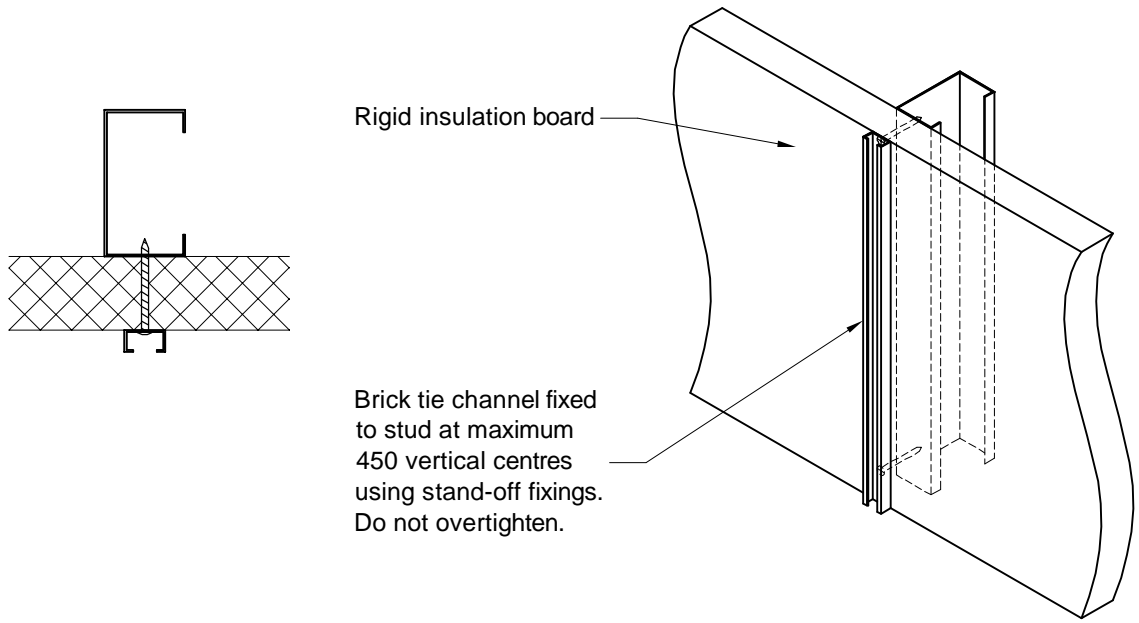

DETAIL SF822

Fixing Brick Tie Channels

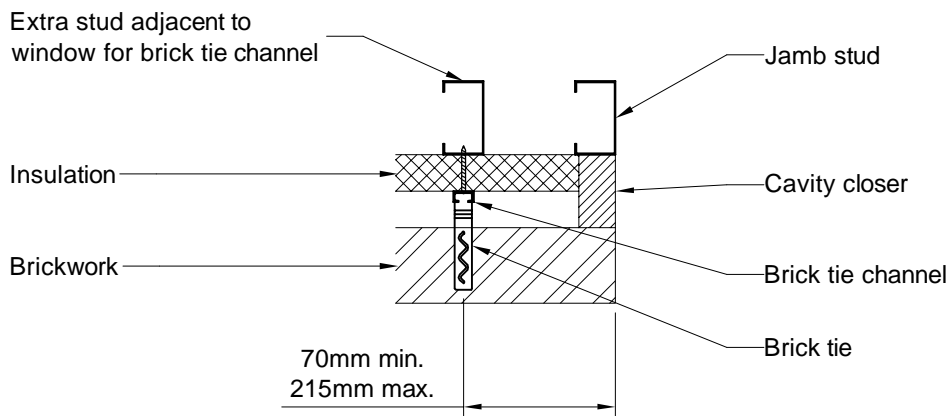

DETAIL SF823

Brick Tie Detail Adjacent to Opening

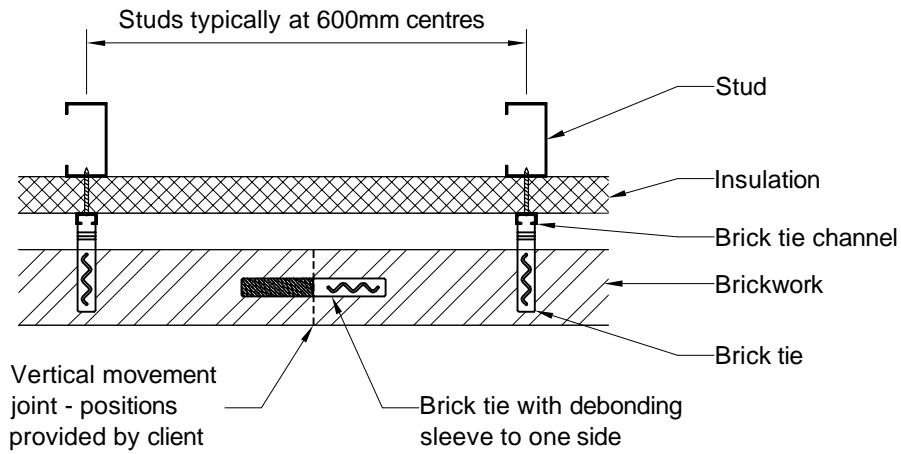

DETAIL SF824

Brick Tie Detail Adjacent Movement Joint

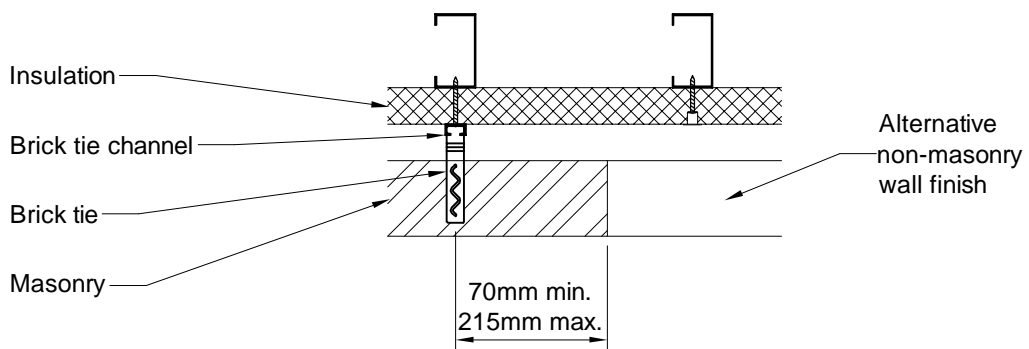

DETAIL SF825

Stud / Brick Tie Arrangement at End of Masonry-Finished Area

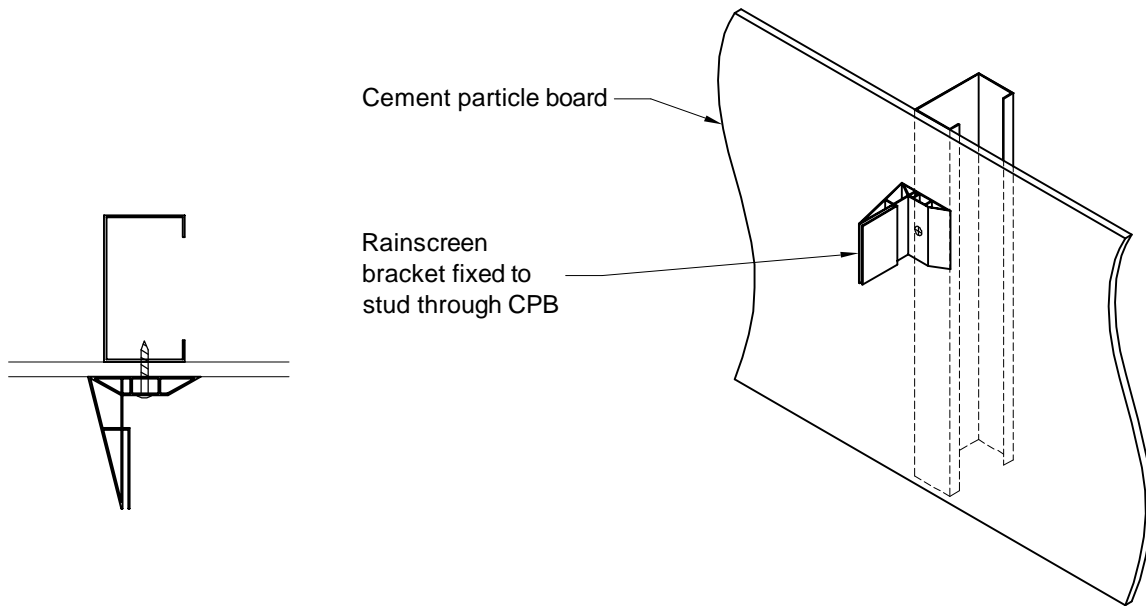

DETAIL SF831
 Typical Rainscreen Brackets

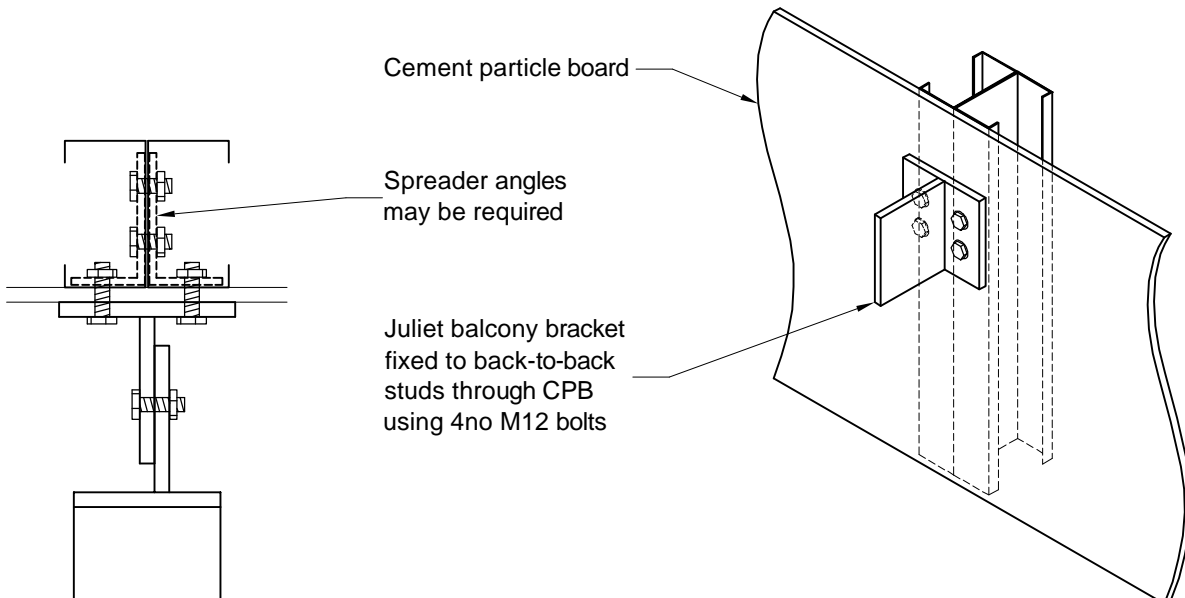

DETAIL SF832
 Typical Juliet Balcony Brackets

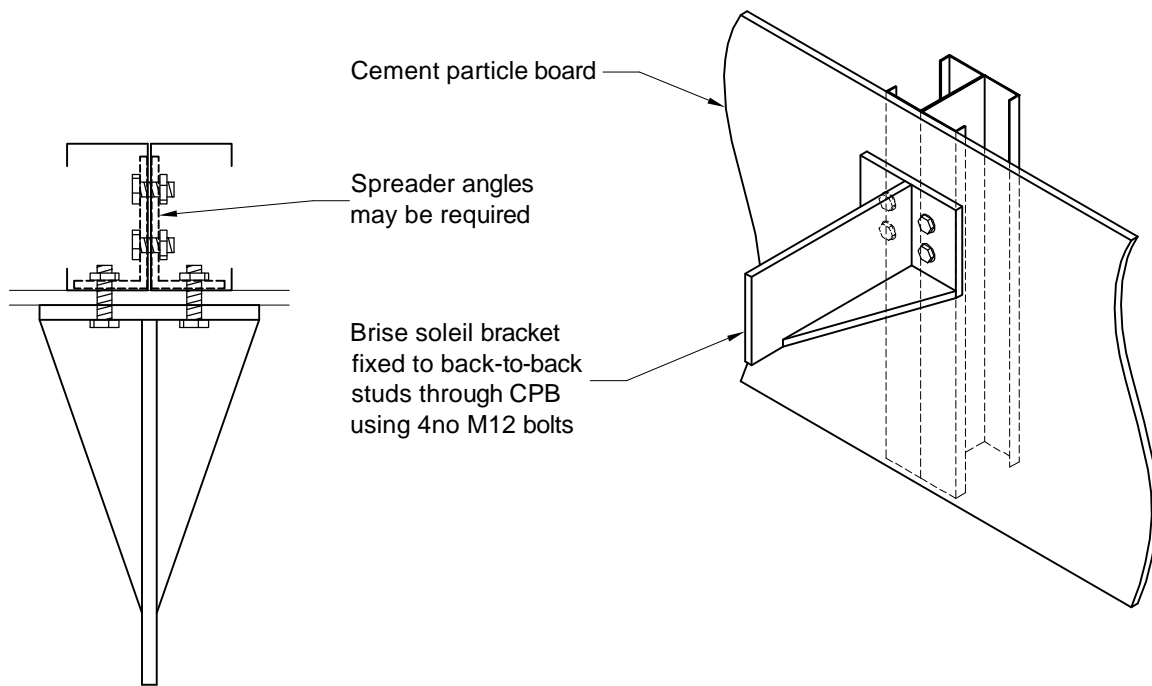

DETAIL SF833

Typical Brise Soleil Brackets



Section A - Metsec Framing Fixing Application Guide

Notes on the Fixing Guide:

- Only the fixings specified below or similar recommended should be used with Metsec Framing.
- For similar recommended fixings please contact Metsec.
- Fixing codes have been supplied by the fixing manufacturer and in the event of any fixing not performing as required the fixings manufacturer should be contacted before Metsec.
- Fixings given below are a guide to the range of fixings often used with Metsec Framing. Project specific fixings may be used in addition to those given below and these will be shown on the Metsec project specific details.
- Unless specified or noted all Pan Head, Low Profile or Countersunk screws have a P2 Phillips recess and all Hex Head Screws have a AF 8mm head.

Fixing manufacturers contact details:

Hilti (Gt. Britain) Limited
1 Trafford Wharf Road
Trafford Park
Manchester
M17 1BY

Freephone: 0800 886 100
Freefax: 0800 886 200

www.hilti.co.uk

ITW Construction Products
Customer Services
R8 Blair Court
100 Borron Street
Port Dundas Business Park
Glasgow
G4 9XG

Main Telephone: 0141 342 1660
Main Facsimile: 0141 332 7489

Freephone Orderline: 0800 833381
Free Fax Orderline: 0800 521077

Technical Helpline
Freephone: 0800 7314924

www.itwcp.co.uk

EJOT U.K Limited
Hurricane Close
Sherburn Enterprise Park
Sherburn-in-Elmet
GB-Leeds
LS25 6PB

Tel: 01977 68 70 40
Fax: 01977 68 70 41

www.ejot.co.uk

Pictures shown have been provided courtesy of Hilti (Gt. Britain) Limited and represent their range of fixings only.

Table 1 - General Framing Fixings

	Application	Description	Picture	Hilti Product Code	Spit Product Code	Ejot Product Code
5	General framing screw fixing studs/joist/runners and bracing sections. 1.2-1.5mm to 1.2-1.5mm steel.	5.5mm Diameter Pan Head Screw		S-MD01ZW 5.5x19	CFC26 ⁽¹⁾	JT2-NH3-5.5x19
		5.5mm Diameter Low Profile Head Screw		S-MD03ZW 5.5x25	CFC26 ⁽¹⁾	LSCF 5.5x25 (P3 Recess)
		5.5mm Diameter Hex Head Screw		S-MD03Z 5.5x25 ⁽²⁾	TC25	LS 5.5x25
5	General framing screw fixing studs/joist/runners and bracing sections. 1.2-3.0mm max to 3.0-12.5mm max steel.	5.5mm Diameter Low Profile Head Screw		S-MD05ZW 5.5x40	CFL32	HSCF 5.5x38 (P3 Recess)
		5.5mm Diameter Hex Head Screw		S-MD05Z 5.5x40	TL38	HS 5.5x38
		Powder Actuated Nail Fixing to Hot Rolled Steel		X-U 16 P8 or X-U 16 MX ^(3,4)	SC9 or SBR9 ⁽⁴⁾	None

Notes:

1. The CFC26 has an ITW exclusive Phillips Square Drive (2PPSD)
2. If the material build-up is over 5.5mm then the Hilti fixing required will be S-MD03Z 6.3x25.
3. Please see approved **Data Sheet** and **Installer Guide** for this application available from Metsec / Hilti. The Hilti X-U nail has no maximum base steel thickness.
4. The use of Powder Actuated Nail Fixings must be approved by Metsec for each individual project due to the large range in fixing load capacities.



Table 2 - Fixings to Concrete

	Application	Description	Picture	Hilti Product Code	Spit Product Code	Ejot Product Code
1	Fixing 1.2-3.0mm Steel to Concrete	Concrete Screw Anchor Hex Head		HUS-H 7.5x35 ⁽¹⁾	4H32 ⁽¹⁾	4H 6.3x32 ⁽¹⁾
		Powder Actuated Nail Fixing into Predrilled Hole using Hilti DX-Kwik Method ⁽²⁾		X-DNH 37-P8 ⁽²⁾	None	None
2	Fixing 3.0-15.0mm Steel to Concrete	Concrete Screw Anchor Hex Head		HUS-H 7.5x45 ⁽¹⁾	4H45 ⁽¹⁾	4H 6.3x45 ⁽¹⁾
3	Fixing 1.2-15.0mm Steel to Concrete ⁽³⁾	Large Diameter Concrete Screw Anchor Hex Head		Range of HUS-H 10.5x55 to HUS-H 16.5x160	Range of LDT M10x45 to LDT M20x159	Range of LDT M10x45 to LDT M20x159
		Stud Anchors		Range of HST M8/10 to HST M24/60	Range of HDP 06/10 to HDP 20/50	None
		Chemical / Adhesive Anchors		Range of HVU M8 to HVU M24 with HAS Rod	Range of Maxima M8 to Maxima M24 with studs	None

Notes:

1. Screw anchors listed are the shortest that can be used in the range. Longer fixing may be specified by Metsec Design.
2. Please see approved **Data Sheet and Installer Guide** for this application available from Metsec / Hilti. Powder Actuated Nail Fixings have a minimum edge distance of 80mm to the edge of the concrete. The use of Powder Actuated Nail Fixings must be approved by Metsec for each individual project due to the large range in fixing load capacities.
3. Large anchors are designed on a project by project basis and the different makes cannot be substituted for each other. All head types vary.



Table 3 - Fixing Insulation to Steel

Application ⁽¹⁾	Description	Picture	Hilti Product Code ⁽²⁾	Spit Product Code ⁽²⁾	Ejot Product Code
Fixing 50mm Insulation to 1.2mm Steel	Large Washer with Stainless Countersunk Head Screw		None	None	IT/S 5/60 Washer with TKE 4.8x70
Fixing 50mm Insulation to 1.2-3.0mm Steel	Large Washer with Stainless Hex Head Screw		S-MD03S 5.5x80	TC75	SBV 90 Washer with JT3-3-5.5x70
Fixing 50mm Insulation to 3.0-6.0mm Steel	Large Washer with Stainless Hex Head Screw		S-MD05S 5.5x82	Contact Spit	SBV 90 Washer with JT3-6-5.5x70

Notes:

1. Application shown is for fixing 50mm insulation. For other insulation thicknesses please consult the fixing manufacturers' product range and select the appropriate length of fixing.
2. Hilti and ITW products do not contain the large washers however the fixings shown will work with the SBV 90 washer from Ejot.

Table 4- Fixing Brick Tie Channels to Steel





Application ⁽¹⁾	Description	Picture	Hilti Product Code	Spit Product Code	Ejot Product Code
Fixing BTC via 50mm Insulation to 1.2-3.0mm Steel	5.5mm Diameter Stainless Hex Head Screw with EPDM sealing washer.		S-CD63S 5.5x85	SCOTS Fixing	JT3-D-3-5.5x82 S16
Fixing BTC via 50mm Insulation to 3.0-6.0mm Steel	5.5mm Diameter Stainless Hex Head Screw with EPDM sealing washer.		S-CD63S 5.5x85	SCOTS Fixing	JT3-D-6H-5.5x87 S16

Notes:

1. Application shown is for fixing 50mm insulation. For other insulation thicknesses please consult the fixing manufacturers' product range and select the appropriate length of fixing.

Table 5 - Fixing Sheathing Boards and Timber to Steel







These types of fixings are suitable for the following types of sheathing boards:
 Cement Particle Board, Cement Fibre Board, PLY Board, Oriented Strand Board, Chipboard and Timber.

Application ⁽¹⁾	Description	Picture	Hilti Product Code	Spit Product Code ⁽²⁾	Ejot Product Code ⁽²⁾
Fixing to 1.2-3.0mm Steel. Board thickness 6.0mm to 19mm	4.8mm Diameter Wafer/CSK Ribbed Head Wing Tipped Screw		S-WD12Z 4.8x38	TFC36 or RKC 41	WDLS 4.8x38
Fixing to 1.2-3.0mm Steel. Board thickness 13mm to 29mm	5.5mm Diameter Wafer/CSK Ribbed Head Wing Tipped Screw		S-WD12Z 5.5x50	TFC50 or RKC 41	WDLS 5.5x50
Fixing to 1.2-3.0mm Steel. Board thickness 25mm to 60mm	5.5mm Diameter Wafer/CSK Ribbed Head Wing Tipped Screw		S-WD12Z 5.5x85	TFC80	WDLS 5.5x85
Fixing to 1.2-3.0mm Steel. Board thickness 65mm to 100mm	5.5mm Diameter Wafer/CSK Ribbed Head Wing Tipped Screw		S-WD12Z 5.5x100 ⁽³⁾	TFC120	WDLS 5.5x127
Fixing to 3.0-6.0mm Steel. Board thickness 10.0mm to 24mm	5.5mm Diameter Wafer/CSK Ribbed Head Wing Tipped Screw		S-WD15Z 5.5x65	TFL65	WDHS 5.5x65

Notes:

1. Applications shown are for regularly selected boarding/timber thicknesses. For other thicknesses please consult the fixing manufacturers' product range and select the appropriate length of fixing.
2. P3 Phillips recess drive bit required in 5.5 diameter screws in the Ejot and ITW product range.
3. Up to 82mm only

Table 6 - Fixing Plasterboard to Steel

Application ⁽¹⁾	Description	Picture	Hilti Product Code	Spit Product Code ⁽²⁾	Ejot Product Code ⁽²⁾
Fixing to 1.2mm Steel. Single board up to 15mm thick.	3.5mm Diameter Bugle/Wafer/CSK Ribbed Head Screw		S-DD01B 3.5x25	TFC36 or RKC 41	WDLS 4.8x38
Fixing to 1.2mm Steel. Double boards up to 30mm combined thickness.	3.5mm Diameter Bugle/Wafer/CSK Ribbed Head Screw		S-DD01B 3.5x45	TFC80 or RKC 41	WDLS 5.5x85
Fixing to 1.2-2.0mm Steel. Single board up to 15mm thick.	3.5mm Diameter Bugle/Wafer/CSK Ribbed Head Screw		S-DD01B 3.5x25	TFC36 or RKC 41	WDLS 4.8x38
Fixing to 1.2-2.0mm Steel. Double boards up to 30mm combined thickness.	3.5mm Diameter Bugle/Wafer/CSK Ribbed Head Screw		S-DD01B 3.5x45	TFC80	WDLS 5.5x85
Fixing to 2.0-6.0mm Steel. Single board up to 15mm thick.	4.8mm Diameter Wafer/CSK Ribbed Head Wing Tipped Screw		S-WD12Z 4.8x38	TFC36	WDLS 4.8x38
Fixing to 2.0-6.0mm Steel. Double boards up to 30mm combined thickness.	5.5mm Diameter Wafer/CSK Ribbed Head Wing Tipped Screw		S-WD12Z 5.5x85	TFC80	WDLS 5.5x85

Notes:

- Applications shown are for regularly selected boarding thicknesses. For other thicknesses please consult the fixing manufacturers' product range and select the appropriate length of fixing.
- ITW & Ejot require wing tipped screws of 4.8 & 5.5 diameters for lower thicknesses of steel as no plasterboard screws available.

Lightweight Structural Systems

SFS Division

Fast-Track Steel Building Systems
Tel: +44(0) 121 601 6000
Fax: +44(0) 121 601 6021
sfs@metsec.com

Metframe Division

Pre-panelised Framing System
Tel: +44(0) 121 601 6000
Fax: +44(0) 121 601 6021
metframe@metsec.com

Lattice Beam Division

Lightweight Lattice Joists and Trusses
Tel: +44(0) 121 601 6000
Fax: +44(0) 121 601 6109
lattice@metsec.com

Purlin Division

Z and C-Sections for Building Shell Applications
C-Sections for Mezzanine Floors
Tel: +44(0) 121 601 6000
Fax: +44(0) 121 601 6065
purlin@metsec.com

Metstrut Division

Cable Ladder and Metal Framing Systems
for M&E Support
Tel: +44(0) 121 601 6085
Fax: +44(0) 121 601 6177
metstrut@metsec.com

Hepsec Division

Dry Linings, Partitioning and Ceiling Support Systems
Tel: +44(0) 2476 585600
Fax: +44(0) 2476 585649
hep@metsec.com

Metsec plc is a member of the Profilform Division of the voestalpine group with companies in Austria, Belgium, Brazil, Czech Republic, France, Germany, Russia and the U.S.A.

© Copyright METSEC plc 2009
In the interests of a policy of continuous research and development, Metsec Building Products Ltd reserve the right to change the specifications in this publication without prior notice.

Metsec plc

Broadwell Road, Oldbury, West Midlands, B69 4HF
Tel: 44+ (0) 121 601 6000
Fax: 44+ (0) 121 601 6109
email: framing@metsec.com
www.metsec.com

voestalpine

ONE STEP AHEAD.