

## STANDARD DRAWING/ ORDER SHEETS

### INDEX

STANDARD DRAWING SHEET PURLINS/ RAILS	PAGE 1
STANDARD DRAWING SHEET EAVES BEAMS	PAGE 2
STANDARD DRAWING SHEET BUILDING SHELL C-SECTION	PAGE 3
STANDARD DRAWING SHEET C-SECTION SLEEVES	PAGE 4
STANDARD DRAWING SHEET CLEADER ANGLE	PAGE 5
STANDARD DRAWING SHEET ACCESSORIES 'A'	PAGE 6
STANDARD DRAWING SHEET ACCESSORIES 'B'	PAGE 7
STANDARD DRAWING SHEET ACCESSORIES 'C'	PAGE 8
STANDARD DRAWING SHEET ACCESSORIES 'D'	PAGE 9
STANDARD DRAWING SHEET ACCESSORIES 'E'	PAGE 10
STANDARD DRAWING SHEET ACCESSORIES 'F'	PAGE 11
STANDARD DRAWING SHEET ACCESSORIES 'G'	PAGE 12
STANDARD DRAWING SHEET ACCESSORIES 'H'	PAGE 13
STANDARD DRAWING SHEET ACCESSORIES 'I'	PAGE 14
STANDARD DRAWING SHEET ACCESSORIES 'J'	PAGE 15
STANDARD DRAWING SHEET ACCESSORIES 'K'	PAGE 16
STANDARD DRAWING SHEET ACCESSORIES 'L'	PAGE 17
STANDARD DRAWING SHEET ACCESSORIES 'M'	PAGE 18
STANDARD DRAWING SHEET ACCESSORIES 'N'	PAGE 19
DETAILING INFORMATION SHEET 'DIS – 1'	PAGE 20
DETAILING INFORMATION SHEET 'DIS – 2'	PAGE 21
DETAILING INFORMATION SHEET 'DIS – 3'	PAGE 22
STANDARD DRAWING SHEET MEZZANINE C-SECTIONS	PAGE 23
STANDARD DRAWING SHEET MEZZANINE ACCESSORIES	PAGE 24

ABSOLUTE MAXIMUM LENGTH 16 METRES  
 STANDARD HOLE PIERCINGS:-  
 WEB: 18MM DIA. ON GAUGE LINES ONLY  
 FLANGE: 18MM DIA. ON CENTRE LINE ONLY

SECTION REFERENCE

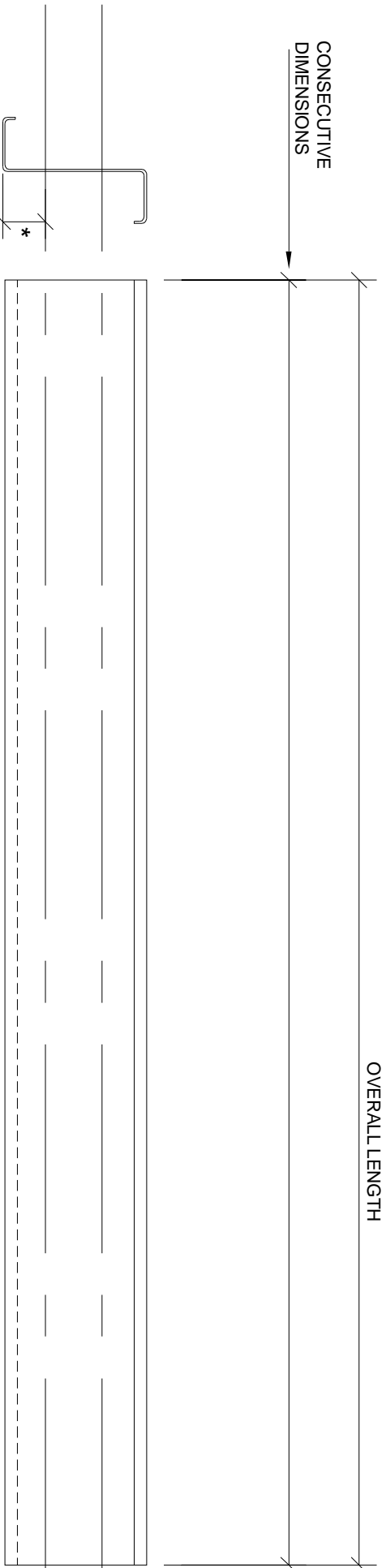

SECTION DEPTH	*	GAUGE LINES
142	42	56
172	42	86
202	42	116
232	42	146
262	42	176
302	52	195
342	52	235

MARK: \_\_\_\_\_ NO. REQD \_\_\_\_\_ AS DRAWN  
 MARK: \_\_\_\_\_ NO. REQD \_\_\_\_\_ OPP. HAND

ALL GALVANISED ROLLED STEEL SECTIONS  
 MANUFACTURED FROM S450GD + Z275

REVISION DATE DESCRIPTION

NOTES:

DRAWN	DATE	PROJECT	 <b>voestalpine</b> <small>ONE STEP AHEAD.</small>	JOB No.
	CHECKED			
CLIENT	TITLE		DWG No.	
PURLINS/ RAILS STANDARD SHEET		REV		



**voestalpine**

ONE STEP AHEAD.

MetssecPbc,  
 Purlin Division,  
 Broadwell Road, Oldbury,  
 West Midlands B69 4HF  
 T: +44 (0) 121 601 6000  
 F: +44 (0) 121 601 6114  
 E: purlin@metssec.com  
 www.metssec.com

ABSOLUTE MAXIMUM LENGTH 12 METRES  
 STANDARD HOLE PIERCINGS:-  
 WEB: 18MM DIA. ON GAUGE LINES ONLY  
 FLANGE: 18MM DIA. 45mm BACK MARK  
 COUNTERFORMED HOLES THUS:



SECTION REFERENCE	TOP FLANGE ANGLE

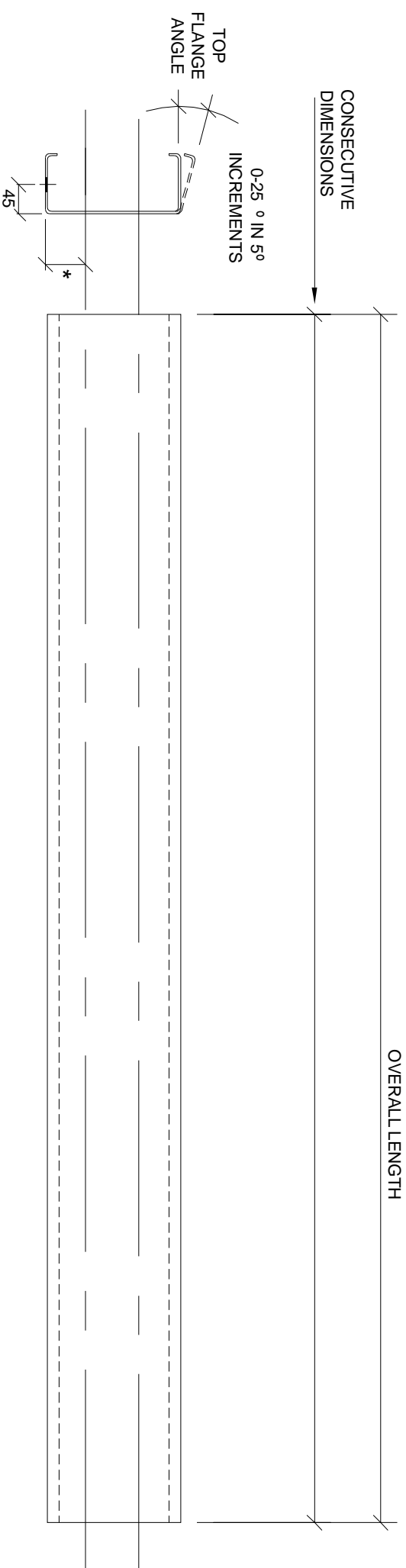

SECTION DEPTH	*	GAUGE LINES
170	42	86
230	42	146
270	47	176
330	47	235

MARK: \_\_\_\_\_ No. REQD \_\_\_\_\_ AS DRAWN  
 MARK: \_\_\_\_\_ No. REQD \_\_\_\_\_ OPP. HAND

ALL GALVANISED ROLLED STEEL SECTIONS  
 MANUFACTURED FROM S450GD + Z275

REVISION DATE DESCRIPTION

NOTES:

DRAWN DATE

CHECKED DATE

CLIENT



Metssec Pty. Ltd.  
 Puriri Division  
 Broadwell Road, Oldbury  
 West Midlands B69 4HF  
 T: +44 (0) 121 601 6000  
 F: +44 (0) 121 601 6114  
 E: puriri@metssec.com  
 www.metssec.com

PROJECT ONE STEP AHEAD.

JOB No.

TITLE EAVES BEAMS STANDARD SHEET

DWG No.

REV

ABSOLUTE MAXIMUM LENGTH 16 METRES  
 STANDARD HOLE PIERCINGS:-  
 WEB: 18MM DIA. ON GAUGE LINES ONLY  
 FLANGE: 18MM DIA. ON CENTRE LINE ONLY  
 COUNTERFORMED HOLES THUS:



SECTION REFERENCE

OVERALL LENGTH

CONSECUTIVE  
 DIMENSIONS

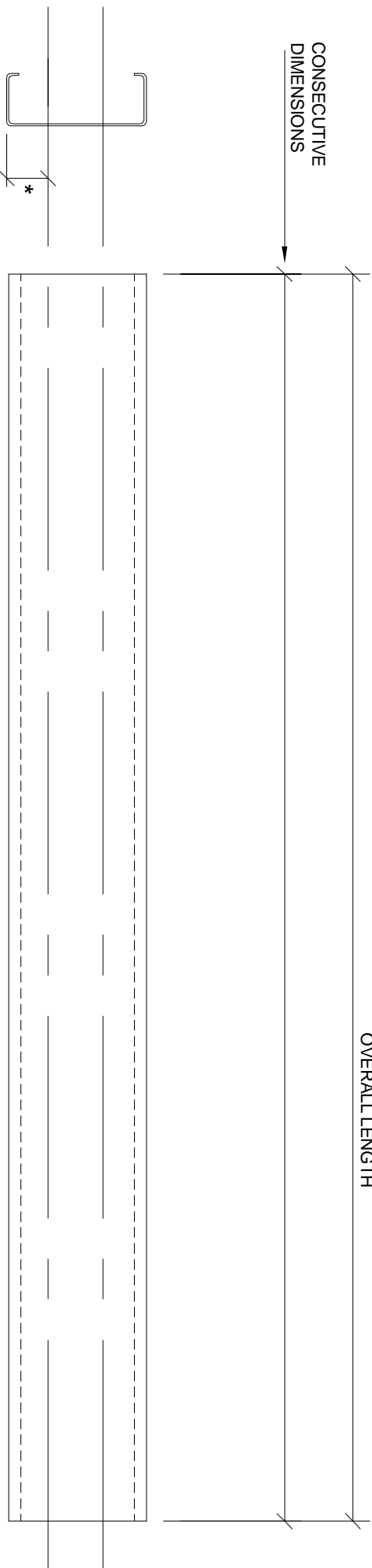

SECTION DEPTH	* GAUGE LINES	GAUGE LINES
142	43	56
172	43	86
202	43	116
232	43	146
262	43	176
302	53	195
342	53	235

MARK: \_\_\_\_\_ No. REQD \_\_\_\_\_ AS DRAWN

MARK: \_\_\_\_\_ No. REQD \_\_\_\_\_ OPP. HAND

ALL GALVANISED ROLLED STEEL SECTIONS  
 MANUFACTURED FROM S450GD + Z275

REVISION DATE DESCRIPTION

NOTES:

DRAWN DATE

CHECKED DATE

CLIENT



ONE STEP AHEAD.

Metssec plc.  
 Pulini Division,  
 Broadwell Road, Oldbury,  
 West Midlands B69 4HF  
 T: +44 (0) 121 601 6000  
 F: +44 (0) 121 601 6114  
 E: pulini@metssec.com  
 www.metssec.com

TITLE  
 BLDG SHELL C-SECTION STANDARD SHEET

PROJECT

JOB No.

DWG No.

REV

















**EAVES BRACE - PURLIN TO EAVES BEAM**

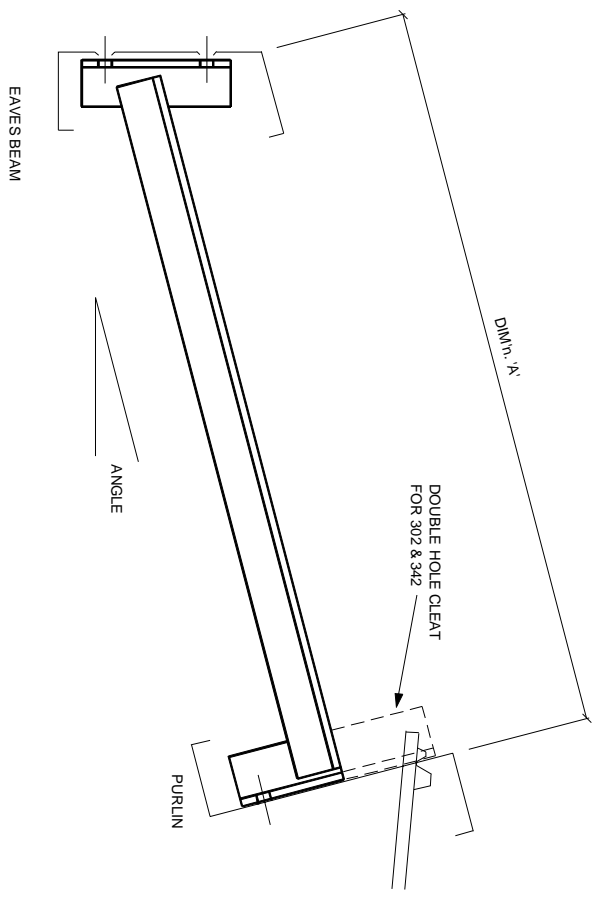

MATERIAL: 45\*45\*2  
 FINISH: GALVANISED  
 ALL HOLES: 18mm DIAMETER

MARK No.	No. REQD	DIM'n. 'A'	EAVES BEAM SIZE	PURLIN SIZE	ANGLE

REVISION DATE DESCRIPTION

NOTES:

**SIDE RAIL SUPPORT - RAIL TO EAVES BEAM**

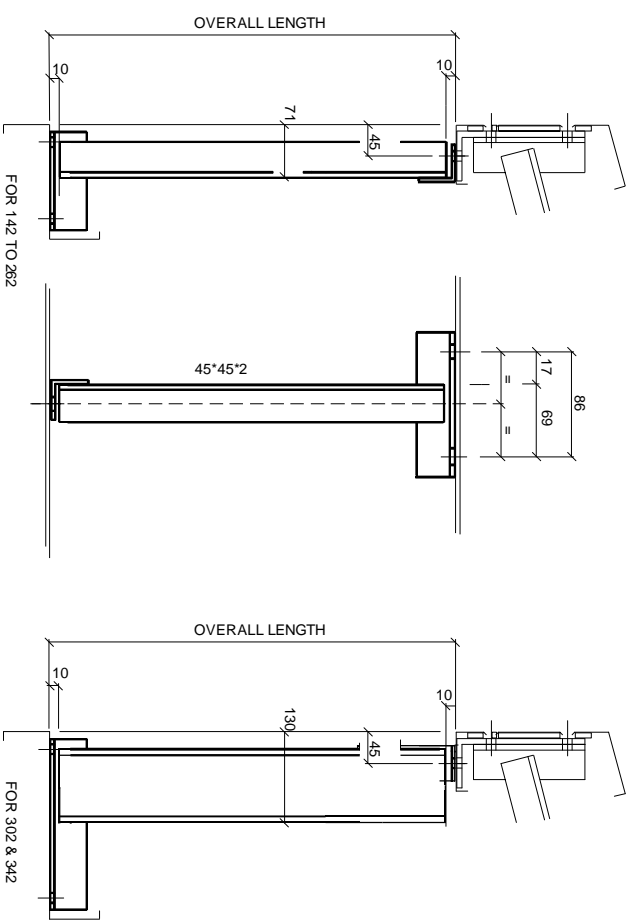

END CLEATS: 45\*45\*2  
 FINISH: GALVANISED  
 ALL HOLES: 18mm DIAMETER

MARK No.	No. REQD	LENGTH	RAIL SIZE

DRAWN DATE

CHECKED DATE

CLIENT

DATE



Metssec, Purlin Division,  
 Broadwell Road, Oldbury,  
 West Midlands B69 4HF  
 T: +44 (0) 121 601 6000  
 F: +44 (0) 121 601 6114  
 E: purlin@metssec.com  
 www.metssec.com

PROJECT ONE STEP AHEAD.

JOB No.

TITLE ACCESSORIES G STANDARD SHEET

DWG No.

REV















DO NOT USE MEISEC WOC VEE SHAPED CLEATS WITH THIS DETAIL

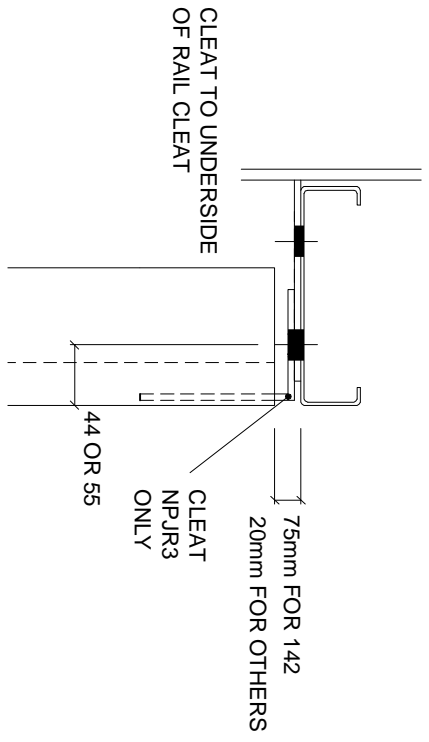

SECTION	142	172	202	232	262	302	342
DIM'n. 'X'	150	180	210	240	270	310	350

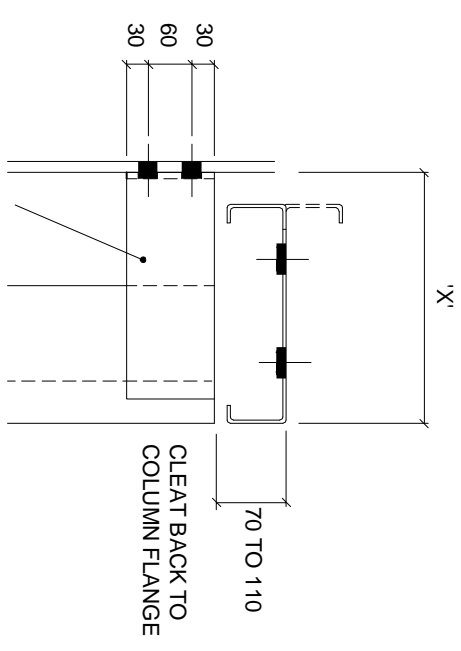

STANDARD NPJR6 CLEATS FOR STANDARD DIMENSIONS 'X' ONLY

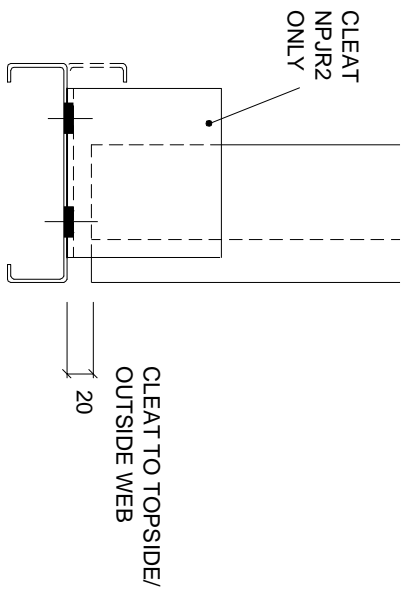

**PJR AT COLUMN POSITION  
HORIZONTAL MEMBER  
FLANGES TOEING UP  
ACCESSORY SHEET 'Ha'**

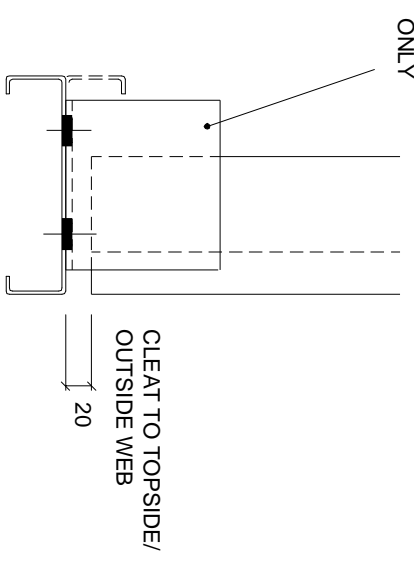

**PJR AT RESTRAINT POSITION  
ACCESSORY SHEET 'G'**

REVISION DATE DESCRIPTION

NOTES:

DRAWN DATE

CHECKED DATE

CLIENT



voestalpine

ONE STEP AHEAD.

Netsecpic,  
Purini Division,  
Broadwell Road, Oldbury,  
West Midlands B69 4HF  
T: +44 (0) 121 601 6000  
F: +44 (0) 121 601 6114  
E: purini@netsec.com  
www.netsec.com

TITLE  
**DIS-1 PJR CLEATS & OFFSETS STANDARDS**

DWG No. REV

PROJECT JOB No.

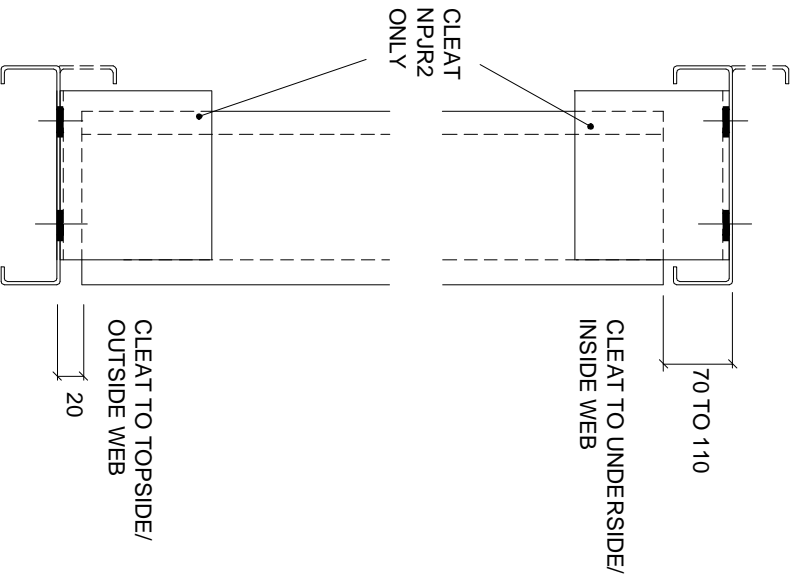

**HCS AT RESTRAINT POSITION  
AND COLUMN POSITION  
ACCESSORY SHEET 'K'**

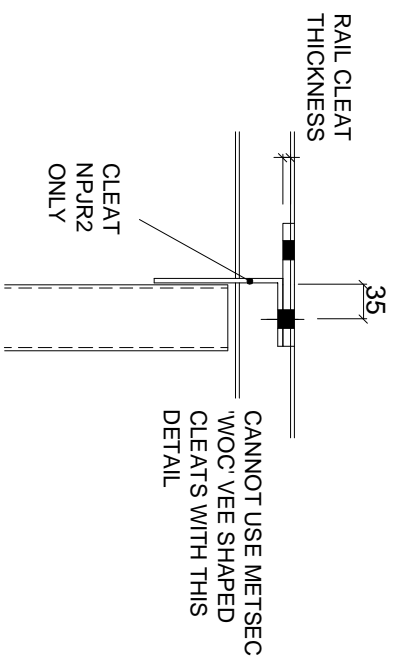

**HCS AT COLUMN POSITION  
ACCESSORY SHEET 'K'**

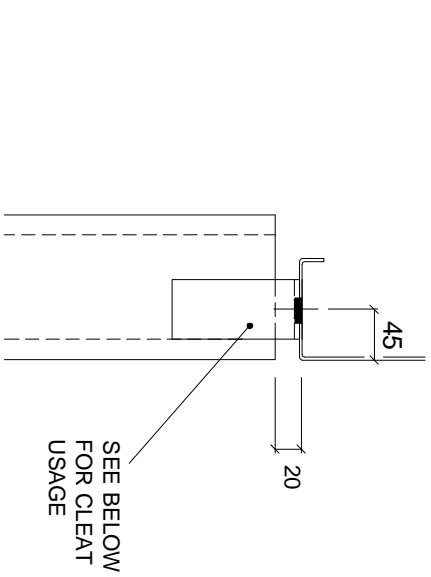

**HCS TO EAVES BEAM AT RESTRAINT  
AND COLUMN POSITION - CLEAT NPJR5  
ACCESSORY SHEET 'L'**

**CLEAT NPJR4 AT COLUMN POSITION  
CLEAT NPJR5 AT COLUMN POSITION  
ACCESSORY SHEET 'J'**

REVISION DATE DESCRIPTION

NOTES:

DRAWN

DATE

CHECKED

DATE

CLIENT

PROJECT

JOB No.



Metsec Pty. Ltd.  
Purlin Division  
Broadwell Road, Oldbury  
West Midlands B69 4HF  
T: +44 (0) 121 601 6000  
F: +44 (0) 121 601 6114  
E: [purlin@metsec.com](mailto:purlin@metsec.com)  
[www.metsec.com](http://www.metsec.com)

ONE STEP AHEAD.

TITLE  
**DIS-2 HCS CLEATS & OFFSET STANDARDS**

DWG No.

REV

**NPJR1 CLEATS**

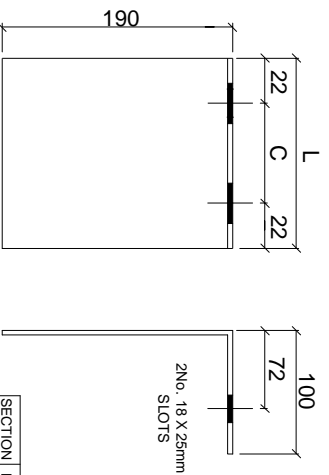

2No. 18 X 25mm SLOTS

SECTION	LENGTH 'L'	CENTRES 'C'
142	100	56
172	130	86
202	160	116
232	190	146
262	220	176
302	239	195
342	279	235

CLEAT NPJR1 FOR USE WITH P.J.R.S & H.C.S.S. SEE ACCESSORY SHEETS 'G' & 'J' FOR USAGE

**NPJR2 CLEATS**

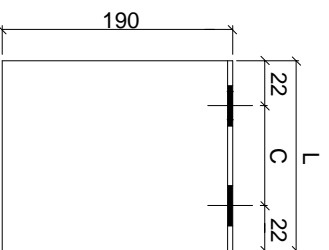

2No. 18 X 25mm SLOTS

SECTION	LENGTH 'L'	CENTRES 'C'
142	100	56
172	130	86
202	160	116
232	190	146
262	220	176
302	239	195
342	279	235

CLEAT NPJR2 FOR USE WITH P.J.R.S & H.C.S.S. SEE ACCESSORY SHEETS 'Hd' & 'Hb' FOR USAGE

**NPJR3 CLEATS**

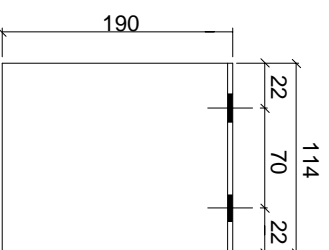

2No. 18 X 25mm SLOTS

SECTION	DIM'n 'A'
142,262	42
302,342	53

CLEAT NPJR3 FOR USE WITH P.J.R.S. SEE ACCESSORY SHEET 'Hd' FOR USAGE

**NPJR4 CLEATS**

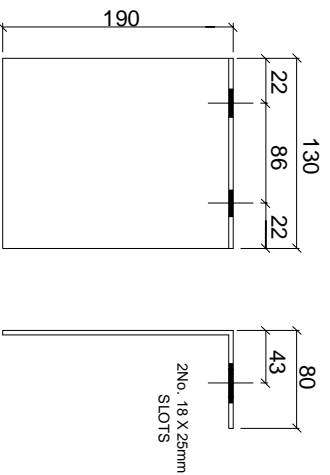

2No. 18 X 25mm SLOTS

CLEAT NPJR4 FOR USE WITH P.J.R.S TO EAVES BEAMS ONLY. SEE ACCESSORY SHEET 'J' FOR USAGE

**NPJR5 CLEATS**

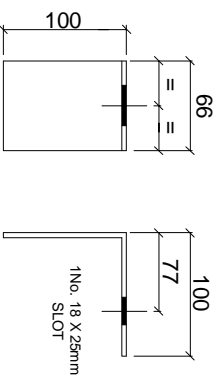

1No. 18 X 25mm SLOT

CLEAT NPJR5 FOR USE WITH H.C.S.S TO EAVES BEAMS ONLY. SEE ACCESSORY SHEET 'L' FOR USAGE

**NPJR6 CLEATS**

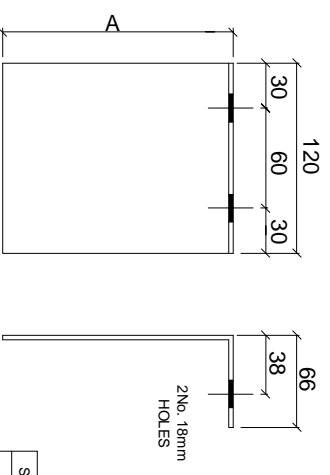

2No. 18mm HOLES

SECTION	DIM'n 'A'
142	128
172	158
202	188
232	218
262	248
302	277
342	317

CLEAT NPJR6 FOR USE WITH P.J.R.S. SEE ACCESSORY SHEETS 'Hb' FOR USAGE

REVISION DATE DESCRIPTION

NOTES:

DRAWN DATE

CHECKED DATE

CLIENT



ONE STEP AHEAD.

MetssecPic,  
Pulini Division,  
Brodwell Road, Oldbury,  
West Midlands B69 4HF  
T: +44 (0) 121 601 6000  
F: +44 (0) 121 601 6114  
E: [Pulini@metssec.com](mailto:Pulini@metssec.com)  
[www.metssec.com](http://www.metssec.com)

PROJECT

JOB No.

DIS-3 P.J.R/H.C.S STANDARD CLEATS

DWG No.

REV



**MEZZANINE INSET CLEATS (MIC)**

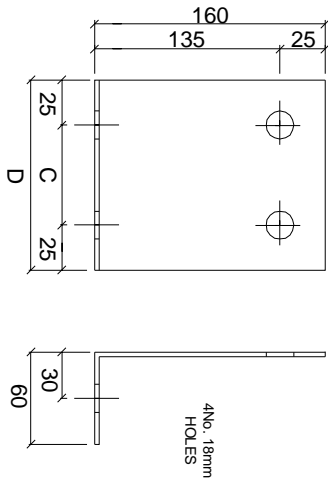

INSET WEB CLEATS ARE AVAILABLE IN 4mm & 5mm THICKNESS. FOR EXAMPLE ORDER AS MIC142x4 \* or MIC142x5 \*

FOR USE WITH MEZZANINE FLOOR 'M' RANGE ONLY.

REFERENCE	DIM'n 'C'	DIM'n 'D'
MIC142xT	60	110
MIC150xT	60	110
MIC165xT	70	120
MIC172xT	70	120
MIC202xT	100	150
MIC220xT	100	150
MIC232xT	130	180
MIC282xT	160	210
MIC302xT	200	250
MIC342xT	240	290

MARK NUMBER *	NUMBER REQUIRED

ALL 4mm & 5mm CLEATS PRE-HOT DIPPED GALVANISED GZ75

**MEZZANINE OVERSAIL CLEATS (MOC)**

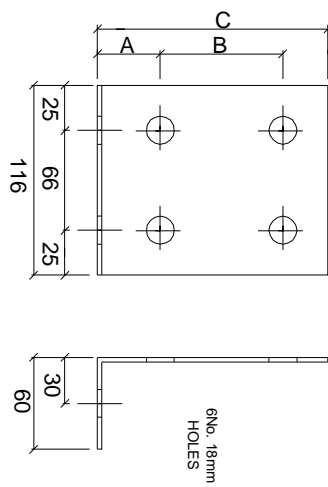

OVERSAIL CLEATS ARE ONLY AVAILABLE IN 4mm. ORDER AS MOC142 \*

FOR USE WITH MEZZANINE FLOOR 'M' RANGE ONLY.

SECTION	DIM'n 'A'	DIM'n 'B'	DIM'n 'C'
MOC142	49	60	134
MOC150	53	60	138
MOC165	55	70	150
MOC172	59	70	154
MOC202	59	100	184
MOC220	68	100	193
MOC232	59	130	214
MOC282	59	160	244
MOC302	59	200	284
MOC342	59	240	324

**MEZZANINE SAG RODS (MSR)**

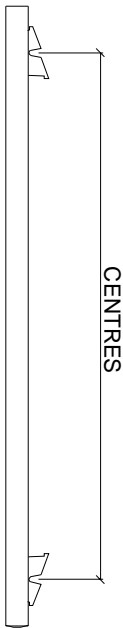

16mm DIAMETER  
FINISH: GALVANISED

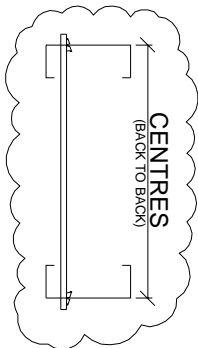

MARK NUMBER	NUMBER REQUIRED	CENTRES

**THREADED RODS (RTB)**

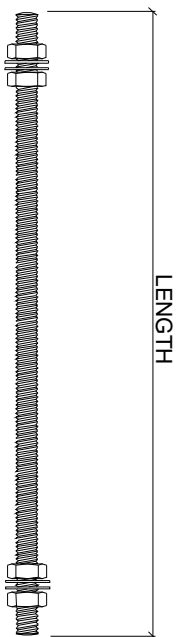

16mm DIAMETER  
FINISH: GALVANISED

MARK NUMBER	NUMBER REQUIRED	OVERALL LENGTH

REVISION DATE DESCRIPTION

NOTES:

DRAWN DATE

CHECKED DATE

CLIENT



ONE STEP AHEAD.

Metssec plc,  
Pulini Division,  
Broadwell Road, Oldbury,  
West Midlands B69 4HF  
T: +44 (0) 121 601 6000  
F: +44 (0) 121 601 6114  
E: [Pulini@metssec.com](mailto:Pulini@metssec.com)  
[www.metssec.com](http://www.metssec.com)

PROJECT

**MEZZANINE ACCESSORIES SHEET**

JOB No.

DWG No.

REV