



THERMOWOOD[®]

SOLUTIONS FOR
TIMBER CLADDING
AND RAIN SCREENS



MetsäWood

DURABLE AND VISUALLY STRIKING

Metsä Wood ThermoWood is produced by heat treating Finnish grown European Redwood/Whitewood (Scandinavian Pine/Spruce) to temperatures in excess of 200 degrees Centigrade. During heat treatment, chemical and structural changes occur within the timber which alter and improve some of its basic characteristics.

The resulting product is an altogether more durable and stable timber, an ideal material for use in exposed areas such as external wall claddings.

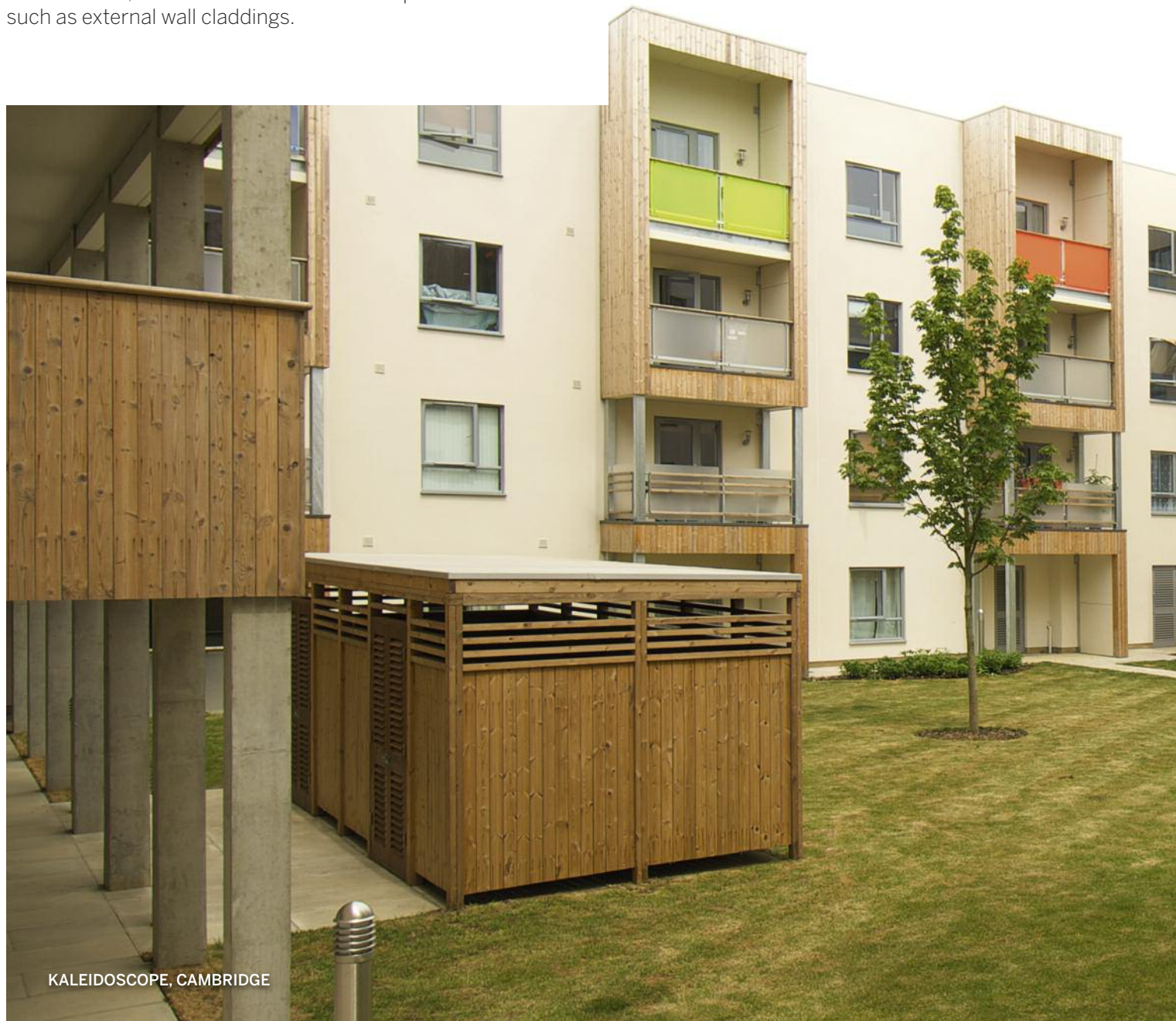

KALEIDOSCOPE, CAMBRIDGE



CONTENTS

INTRODUCTION TO METSÄ WOOD THERMOWOOD	04
THE THERMOWOOD PROCESS	05
THE BENEFITS OF METSÄ WOOD THERMOWOOD	07
METSÄ WOOD THERMOWOOD PROJECTS	07
KEY PROPERTIES	08
PRODUCTS - VISUAL QUALITY	12
PRODUCT PROFILES	14
MOISTURE CONTENT	16
GENERAL DESIGN	17
TYPICAL GENERAL LAYOUTS	20
VENTILATION AND GROUND CLEARANCE	24
CORNER DETAILS	25
INSTALLATION	26
SURFACE TREATMENT AND MAINTENANCE	28
WORKING WITH METSÄ WOOD THERMOWOOD PRODUCTS	30



INTRODUCTION TO METSÄ WOOD THERMOWOOD®

Heat treatment of wood was scientifically studied by Stamm and Hansen in the 1930s in Germany and by White in the 1940s in the United States. In the 1950s, Germans Bavendam, Runkel and Buro continued research into the subject. Kollman and Schneider published their findings in the 1960s, and Rusche and Burmester in the 1970s. More recently, research work was carried out in Finland, France and the Netherlands in the 1990s. The most comprehensive research work was conducted by VTT (Finnish State Research Center) in Finland.

ThermoWood is manufactured using a method developed by VTT. The wood material is heated to a temperature of at least 180 degrees Celsius while it is protected with steam. Besides providing protection, the steam also affects the chemical changes taking place in the wood. As a result of the treatment, environmentally-friendly ThermoWood is created. Its colour darkens, it is more stable than normal wood in conditions of changing humidity and its thermal insulation properties are improved.

If carried out at a sufficiently high temperature, treatment also makes the wood resistant to decay.

HABITAT FOR HUMANITY, SOUTHWARK

THE THERMOWOOD® PROCESS

An industrial scale chemical-free heat-treatment process for wood has been developed at VTT in co-operation with the Finnish wood product industry.

The ThermoWood process is licensed to the members of the Finnish ThermoWood Association. Metsä Wood ThermoWood is available in two treatment classes: Thermo-S (Scandinavian Pine or Spruce, heat treatment 190°C, internal use) and Thermo-D (Scandinavian Pine or Spruce, heat treatment 212°C, internal and external use). Thermowood is fully CE marked and approved.

THE THERMOWOOD PROCESS CAN BE DIVIDED INTO THREE MAIN PHASES:

PHASE 1 TEMPERATURE INCREASE AND HIGH-TEMPERATURE DRYING

Using heat and steam, the kiln temperature is raised rapidly to a level of around 100°C. Thereafter, the temperature is increased steadily to 130°C, during which time the high-temperature drying takes place and the moisture content in the wood decreases to nearly zero.

PHASE 2 HEAT TREATMENT

Once high-temperature drying has taken place, the temperature inside the kiln is increased to between 185°C and 215°C. When the target level has been reached, the temperature remains constant for 2-3 hours depending on the end-use application.

PHASE 3 COOLING AND MOISTURE CONDITIONING

The final stage is to lower the temperature by using water spray systems; when the temperature has reached 80-90°C, re-moisturising takes place to bring the wood moisture content to a useable level, 4-7%.

FIGURE 1. DIAGRAM OF THE PRODUCTION PROCESS.

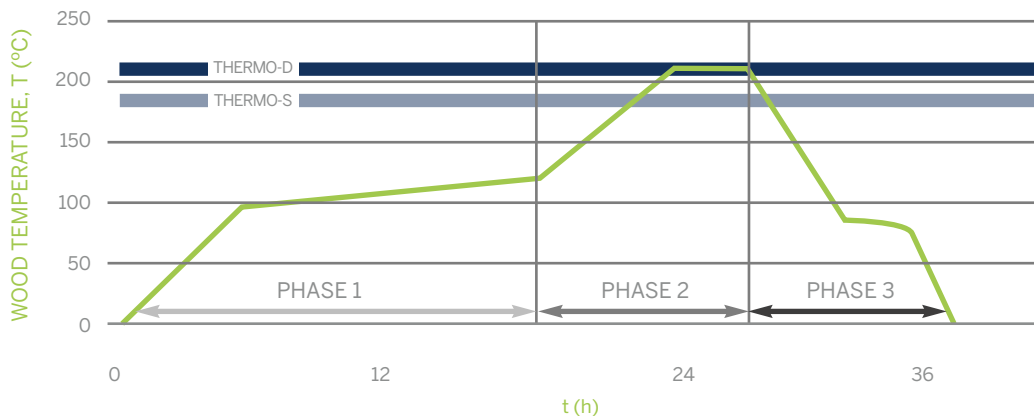



GILLESPIE PARK, HIGHBURY, N LONDON

THE BENEFITS OF METSÄ WOOD THERMOWOOD®

DURABILITY

The improved durability of ThermoWood makes it an excellent material to use in the production of timber claddings and rain screens. The heat treatment process enables the use of Scandinavian Redwood in areas requiring a service life of up to 30 years without the need for a chemical preservative.

ENVIRONMENT

The timber used to produce ThermoWood is grown in our own Finnish forests which are fully certified under the Finnish Forestry Certification System and Pan European Forestry Certification. As such you can be sure ThermoWood is sourced from well managed and sustainable forests. The heat treatment process requires no chemical additives. The improved performance is achieved simply by the controlled application of heat and steam.

STABILITY

ThermoWood is more stable than untreated softwood. The changes that occur within the timber during heat treatment make it less able to absorb or lose moisture. This restriction of moisture movement limits any potential for swelling, shrinkage or distortion of ThermoWood cladding boards.

MAINTENANCE

Heat treatment removes resin from timber. As a result there is no resin leakage or “bleed” through the surface coatings. The combined effect of this together with the improved stability can lead to a lower maintenance requirement.

METSÄ WOOD THERMOWOOD® PROJECTS



SHIPLAP CLADDING

STEAM MILLS PRIMARY SCHOOL, CINDERFORD

APEX ARCHITECTURE,
VINEY HILL



CHANNEL CLADDING

KALEIDOSCOPE, CAMBRIDGE

GRAFIK ARCHITECTURE,
BILLERICAY



VERTICAL CHANNEL CLADDING/ HORIZONTAL RAIN SCREEN

THE OUTLET RETAIL PARK, BANBRIDGE

MCALISTER ARMSTRONG &
PARTNERS ARCHITECTS,
BELFAST



LAMINATED THERMOWOOD®

GILLESPIE PARK, HIGHBURY

BUILT ENGINEERS,
LONDON/COWLEY TIMBERWORK,
WADDINGTON

KEY PROPERTIES

STABILITY

ThermoWood has improved stability when compared with normal kiln-dried Scandinavian Pine and Spruce.

The internal stresses within the structure of timber are reduced when it is treated with the high temperatures of the ThermoWood process. This reduces the potential for twist and warp. In addition there is a decrease in the equilibrium moisture content and water permeability.

There exists a linear correlation between water intake properties and the dimensional stability of the material under changing moisture conditions. Swelling and shrinkage of ThermoWood is only 50% of the corresponding values of untreated Scandinavian Pine and is in a similar range to Teak.

TABLE 1. DIMENSIONAL CHANGES OF THERMOWOOD COMPARED WITH UNTREATED PINE

WOOD SAMPLES	MC %	MC %	DIMENSIONAL CHANGE % PER 1% MC CHANGE		DIMENSIONAL CHANGE 50%RH	
	50%RH	90%RH	THICKNESS	WIDTH	THICKNESS	WIDTH
THERMOWOOD	5%	10 %	0.28	0.17	1.4%	0.85%
PINE HEARTWOOD	10%	20 %	0.3	0.1	3.1%	1.9%

EXAMPLE:

Dimensional change of 118mm wide ThermoWood cladding when 50%RH
90%RH ThermoWood MC change 5% (5%-->10%)
Width change (%) $5\% \times 0.17 = 0.85\%$
Width change in mm $0.0085 \times 118\text{mm} = 1\text{mm}$
Source: ThermoWood Association





KALEIDOSCOPE, CAMBRIDGE

KEY PROPERTIES

DURABILITY

ThermoWood has improved durability due to the reduction of hemicelluloses (arabinose, galactose, xylose, mannose). These are the foodstuff for rot-causing fungi and bacteria and in the absence of nourishment they are not able to occupy ThermoWood.

ThermoWood has high resistance to most decay fungi. ThermoWood is resistant to Longhorn beetles, *Anobium punctatum* and *Lyctus Bruneus*.

NOTE:

ThermoWood is not resistant to the biological growth of algae on its surface. These organisms get their nourishment from the surrounding air and do not cause structural damage. However they are considered in many cases to be an aesthetic problem. Their growth can be prevented by using surface treatments and regular maintenance.

SERVICE LIFE

ThermoWood has improved stability when compared with normal kiln-dried Scandinavian Pine and Spruce.

The risks of fungal and insect attack to any solid wood components used externally are defined in EN335 and 335.2 under the following use classes:

- Use Class 1* *Above ground, protected and not exposed to direct wetting (Wood dry).*
- Use Class 2* *Above ground, protected but exposed to occasional wetting or high humidity (Wood occasionally above 20% moisture content).*
- Use Class 3* *Above ground, protected or unprotected but exposed to frequent wetting (Wood frequently above 20% moisture content).*
- Use Class 4* *Wood is in contact with ground or fresh water, and permanently exposed (Wood continuously above 20% moisture content).*
- Use Class 5* *Wood permanently exposed to salt water.*

External timber cladding is generally assumed to be exposed to Use Classes 2 or 3. The wood may therefore be frequently above 20% moisture content but fungal attack will not occur unless the wood is at sustained moisture content at this level. Even under Use Class 3 a moisture level above 20% would not be expected to be sustained.

To provide adequate resistance to fungal attack under Use Classes 2 and 3, the natural durability of any species should be either durability class 2 (durable) or 3 (moderately durable) as defined under EN350-1:1994.

Tests carried out by YTI (Finland) in accordance with these standards have determined that the ThermoWood 'D' process applied to Scandinavian Pine (European Redwood) and Spruce (European Whitewood) will increase the durability of either wood to the equivalent Durability class 2.

ThermoWood 'D' will therefore provide a 30 year service life, when installed in accordance to the manufacturer's recommendations.

SOURCE: TRADA UK.

BRE has reviewed data supplied by VTT relating to thermally treated timber. On the basis of this evidence, BRE was able to conclude that data for a test material corresponding to ThermoWood® D Pine gave a durability performance equivalent to that acceptable in the UK for cladding, providing a 30 year service life, when following manufacturer's guidance.

SOURCE: BRE (BUILDING RESEARCH ESTABLISHMENT) GROUP.



THE OUTLET, BANBRIDGE

DENSITY

ThermoWood density is 350 - 480kg/m³ when its moisture content is 6% (typical for RH = 65%, t = 20°C conditions). Natural variation will occur between individual boards. Material density is approximately 10% lower than the density of Scandinavian Pine & Spruce.

NAIL & SCREW HOLDING STRENGTH

Nail holding strength values for wire and improved nails for ThermoWood do not differ from the values of European Redwood. However, screw holding strength is about 20% less due to the altered state of the cell wall during the ThermoWood process.

PRODUCTS – VISUAL QUALITY

ThermoWood is produced from European Redwood (Pinus Sylvestris) or European Whitewood (Picea Abies).

The raw material is specially selected and sawn from live knotted logs.

TVOC (Total Volatile Organic Compounds) values are significantly lower than those for untreated softwoods due to the evaporation of most of the terpenes during the heat treatment process.

FIRE PERFORMANCE

According to EN 13501 (SBI-test) ThermoWood is in reaction to fire class D. It is possible to treat further with fire protective treatments in order to achieve Class B under EN 13501 or UK fire rating Class 1, Class 'O' Spread of Flame as defined under BS476 Part 7.

ENVIRONMENT

ThermoWood is PEFC-certificated, which ensures the raw material is sourced from sustainable managed forests.

THERMAL PROPERTIES

Thermal conductivity of ThermoWood is reduced by 20-25% compared with normal softwoods. According to VTT tests the thermal conductivity λ_{10} of ThermoWood. (D, Pine) is 0.099 W/(m K). The corresponding value for untreated sawn timber is 0.12 W/(m K).

MOISTURE CONTENT

ThermoWood has moisture content of 5-7% (50%RH) when packed at production site.

This level will change according to atmospheric conditions. The Equilibrium moisture content is only half of the corresponding value for untreated Pine.

COLOUR

The colour of ThermoWood is affected by the treatment temperature and time. The higher the temperature the darker the appearance.

As with all softwoods, variances occur and are due to varying densities. When ThermoWood is exposed to UV light, it will lose its colour and turn silver grey unless protected by a pigmented surface protection.

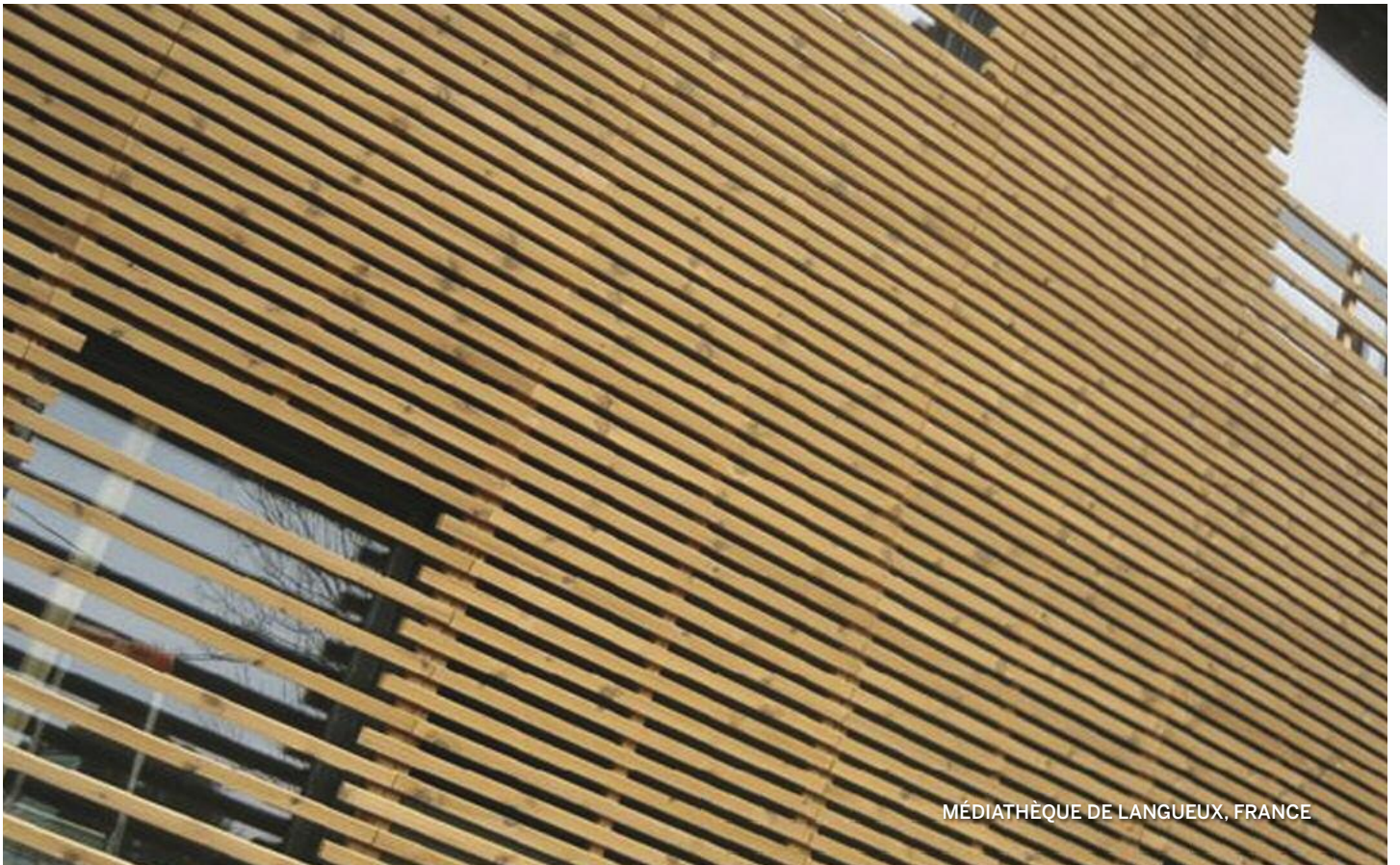

MÉDIATHÈQUE DE LANGUEUX, FRANCE



THE OUTLET, BANBRIDGE

STANDARD PRODUCT PROFILES

T&G SHIPLAP



CODE	FINISHED (MM)*	FINISH
119224	21 x 118	Embossed
157443	21 x 142	Embossed

*Finished (mm) quoted are approximate.

PMV CLADDING



CODE	FINISHED (MM)*	FINISH
119225	21 x 118	Embossed

*Finished (mm) quoted are approximate.

BATTENING/CORNERING



CODE	FINISHED (MM)*	FINISH
138350	20 x 92	4 sides smooth

*Finished (mm) quoted are approximate.

CHANNEL CLADDING



CODE	FINISHED (MM)*	FINISH
119226	21 x 118	Embossed

*Finished (mm) quoted are approximate.

TAPERED CLADDING



CODE	FINISHED (MM)*	FINISH
119227	21 x 142	Embossed

*Finished (mm) quoted are approximate.

BATTENING/CORNERING

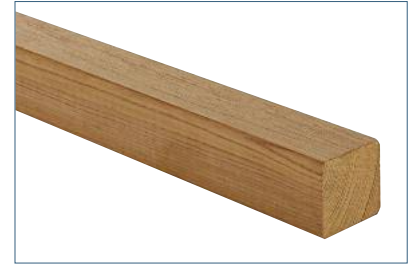

CODE	FINISHED (MM)*	FINISH
138349	42 x 42	4 sides smooth

*Finished (mm) quoted are approximate.

CORNER TRIM L SHAPED SECTION



CODE	FINISHED (MM)*	FINISH
139267	42 x 42	Smooth

*Finished (mm) quoted are approximate.

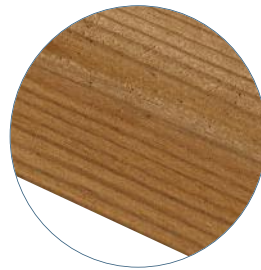

DETAILED
EXAMPLE OF
EMBOSSED FINISH

ThermoWood 'D' pine is available in a variety of finished profiles or as treated sawn material in sizes up to a maximum of 50 x 150mm.

SPECIAL ORDER PRODUCT PROFILES

DUAL SHADOW



CODE	FINISHED (MM)*	FINISH
156287	26 x 142	Embossed
*Finished (mm) quoted are approximate.		

PMV CLADDING



CODE	FINISHED (MM)*	FINISH
56285	21 x 192	Embossed
*Finished (mm) quoted are approximate.		

TAPERED CLADDING



CODE	FINISHED (MM)*	FINISH
156286	20 x 192	Sawn
*Finished (mm) quoted are approximate.		

DUAL CHAMFER



CODE	FINISHED (MM)*	FINISH
156289	26 x 68	Embossed/Smooth
*Finished (mm) quoted are approximate.		

DUAL CHAMFER



CODE	FINISHED (MM)*	FINISH
155102	42 x 42	Embossed
*Finished (mm) quoted are approximate.		

THE PRODUCTS ON THIS PAGE ARE AVAILABLE TO SPECIAL ORDER.

For further information and technical assistance
please email uk@metsagroup.com
or call 0800 00 44 44

MOISTURE CONTENT

The T & G shiplap profile is most appropriate for horizontal cladding as the sloped shoulder will effectively channel water away from the upstand. Tapered profile and PMV can be used for horizontal & vertical applications. PMV can also be used for horizontal cladding. All horizontal tongued and grooved boards should always be installed tongue uppermost.

For vertical cladding the most appropriate profiles are Channel Cladding and PMV, but tapered boards can also be used vertically. A 2mm clearance gap should always be incorporated between the boards to allow for possible expansion. A vertical 'board-on-board' layout can be achieved using standard 21mm x 92mm batten sections or a 'batten-and-board' layout by combining the 42mm x 42mm batten with the 21mm x 92mm section, but consult Metsä Wood for further information.

DESIGN INFORMATION

PRODUCT	ACTUAL WIDTH	COVER WIDTH (INCL. EXPANSION GAP 2MM)	RUNNING METERS / M ²	HORIZONTAL OR VERTICAL APPLICATION
SHIPLAP CLADDING	118mm	110mm	9.1	H
	142mm	134mm	7.5	H
TAPERED CLADDING	142mm	132mm	7.6	H/V
PMV CLADDING	118mm	110mm	9.1	H/V
CHANNEL CLADDING	118mm	110mm	9.1	V

NB. All of the profiles can be used diagonally

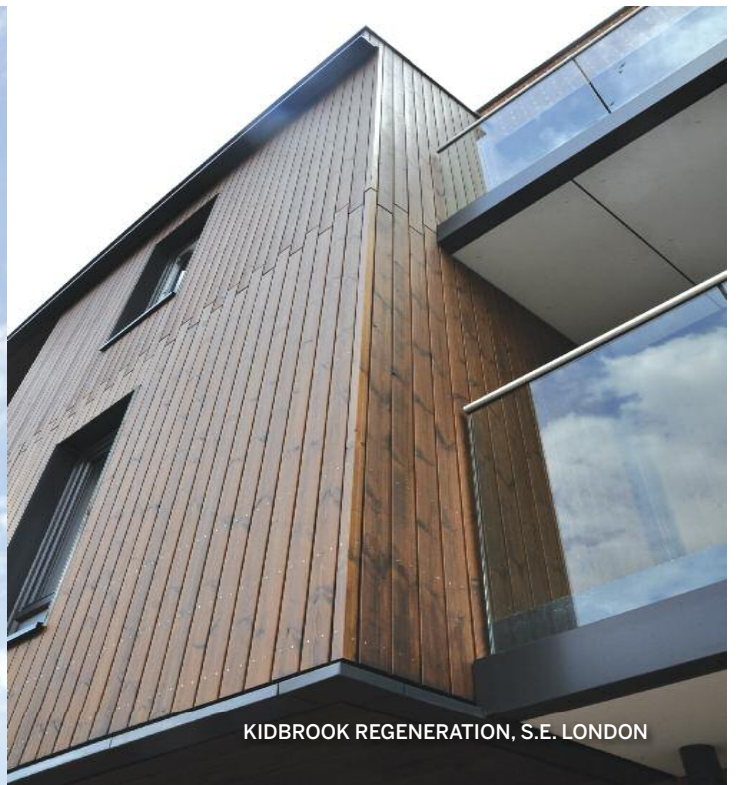

GENERAL DESIGN

The general guidance and schematic details presented in General Design and Installation of this manual have been prepared in accordance with best practice guidelines recommended by TRADA Technology and are specific to ThermoWood.

The purpose of the ThermoWood technical brochure is to ensure the design of a 'rainscreen' form of cladding that gives long service life and low maintenance costs. These instructions are offered as general recommendations. They do not provide structural design. The compatibility of these guidelines to the specific structure should be verified on a case-by-case basis. In short, the basic principles for the installation of ThermoWood cladding may be summarised below.

1. Take into account the surrounding buildings, proximity to boundaries, local vegetation, ground level, and any planning requirements when designing the cladding.
2. Always incorporate a drained and ventilated cavity between the ThermoWood cladding and external walls (i.e. 'rainscreen design'), whether they are of timber frame or masonry construction or outside any externally insulated walls, such as blockwork or cross-laminated timber construction.
3. Ensure that this ventilated cavity extends from the base to the upper edge of the cladding, to ensure that any water penetrating the cavity will drain away and any vapour within the cavity will be diffused away by the vertical flow of air.
4. Providing ventilation at the back of the cladding will also ensure that the moisture content of the boards remains similar on inner and outer faces, avoiding any distortion of the wood that can occur if there is a variation in the moisture content across the thickness of the section.
5. Ensure that there are suitable flashings at the boundaries of the cladding at junctions with other components, and around openings in order to direct water clear of the cladding.
6. Protect cladding from indirect wetting such as splashback off the ground, or at changes in roof level, by ensuring that any ThermoWood component stops at least 200mm above the horizontal surface.
7. Ensure that there will be no vegetation in direct contact with the cladding.
8. Ensure that there is no direct contact between ThermoWood and any porous surfaces that can be wetted or non-porous surfaces on which water can lie. This is particularly important where end grain is exposed which will readily absorb moisture. Protection is often provided by a d.p.c or flashing, but the most effective way is an open air gap. This will not prevent some moisture absorption, but will allow the wood to dry out quickly. Where boards are directly over a metal flashing this gap should be a minimum 10mm. The performance of vertical boards can be enhanced by chamfering the bottom edges, which helps to discharge rainwater to the outside. The top edges should also be well protected. Horizontal boards should stop short of any vertical members by 8mm to allow ventilation to the end grain.
9. If ThermoWood boards are to be left unfinished, a minimum air gap of 5mm should be left at any butt joints between boards. If the boards are to be finished with a coating, they can be tightly butt jointed providing the end grain is sealed prior to installation.
10. If boards are to be finished with a coating, this should be a low-build stain or opaque paint system. One coat should be applied to all surfaces before boards are erected, and this can also be used to seal the end grain of any tight-butted boards.





FMO BUILDING, TAPIOLA, FINLAND

BATTENS

For the purpose of allowing efficient ventilation behind the ThermoWood cladding, the cavity behind the cladding should not be less than 19mm wide, but the width of the ventilation gap is generally determined by the size of battens necessary to fix the boards.

The following rules of thumb regarding the batten sizes should be followed:

- When using improved nails (e.g. annular ring shank), a batten approximately twice the thickness of the board is adequate, i.e. 42mm ThermoWood (38mm if treated softwood). Vertical ThermoWood battens of 21mm thickness are only suitable as counter battens when fixed to timber frame walls and coincident with wall studs.
- When using standard nails rather than 'improved' nails, the battens should be at least 2.5 times the thickness of the boards to be fixed, i.e. 50mm.
- If 42mm x 42mm battens are used, it will be possible to add short lengths of batten to the side of the standard batten in order to provide sufficient width to fix the ends of both boards at a butt joint i.e. total 84mm.

When timber cladding is exposed on elevations of taller buildings or when timber cladding is fixed to a masonry building, the thickness of battens should not be less than 42mm (38mm if treated softwood). This ensures that cladding is fixed robustly to the building.

- When using standard nails, a batten with minimum thickness of 50mm is required.
- When using improved nails (e.g. annular ring shank), the batten should be a minimum thickness of 42mm.

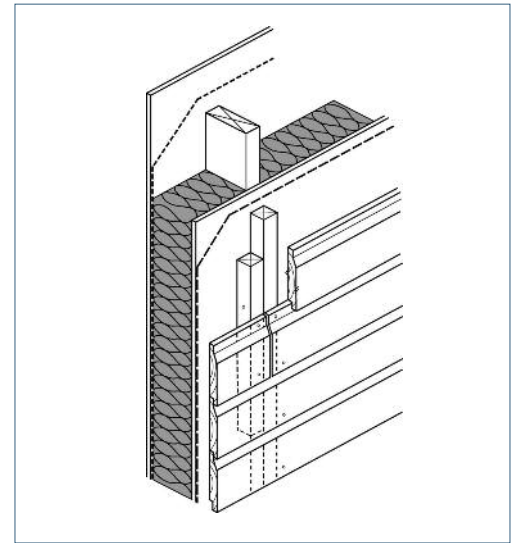

BUTT JOINTING BOARDS
(VERTICAL OR HORIZONTAL) WITH ADDITION OF SHORT LENGTHS OF BATTEN. IMAGE USED WITH KIND PERMISSION OF TRADA UK

TYPICAL GENERAL LAYOUTS

TIMBER FRAME WALLS CROSS-LAMINATED TIMBER (CLT)

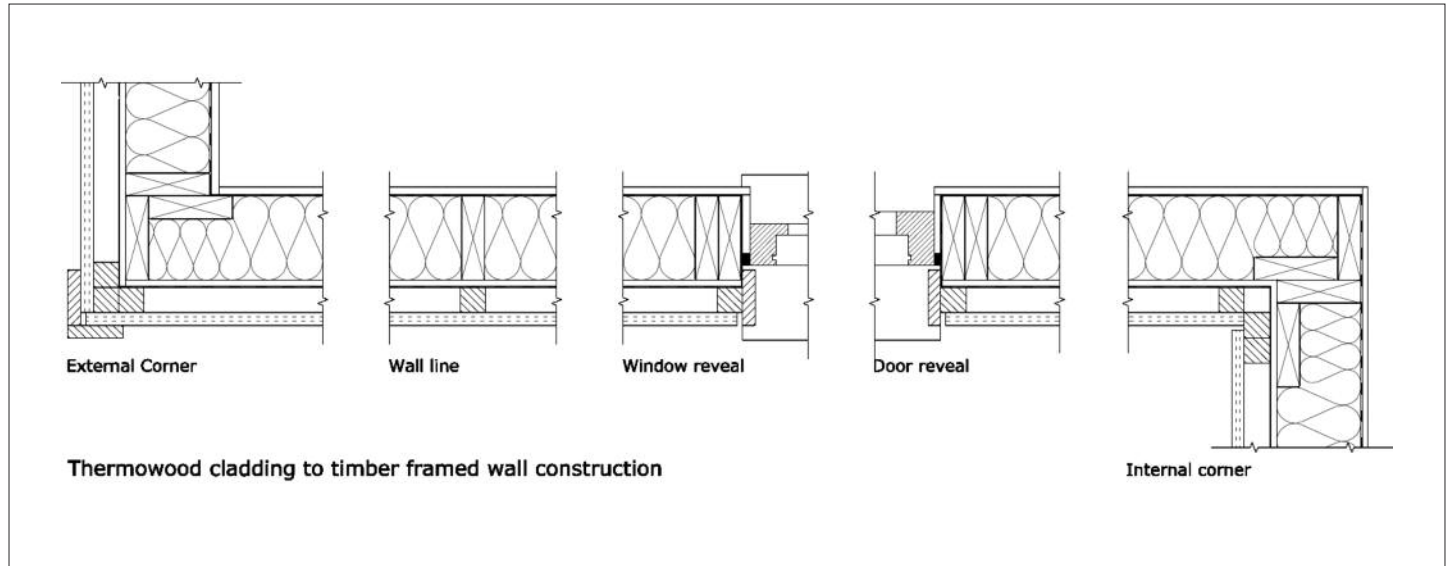

TYPICAL LAYOUT - HORIZONTAL BOARDS

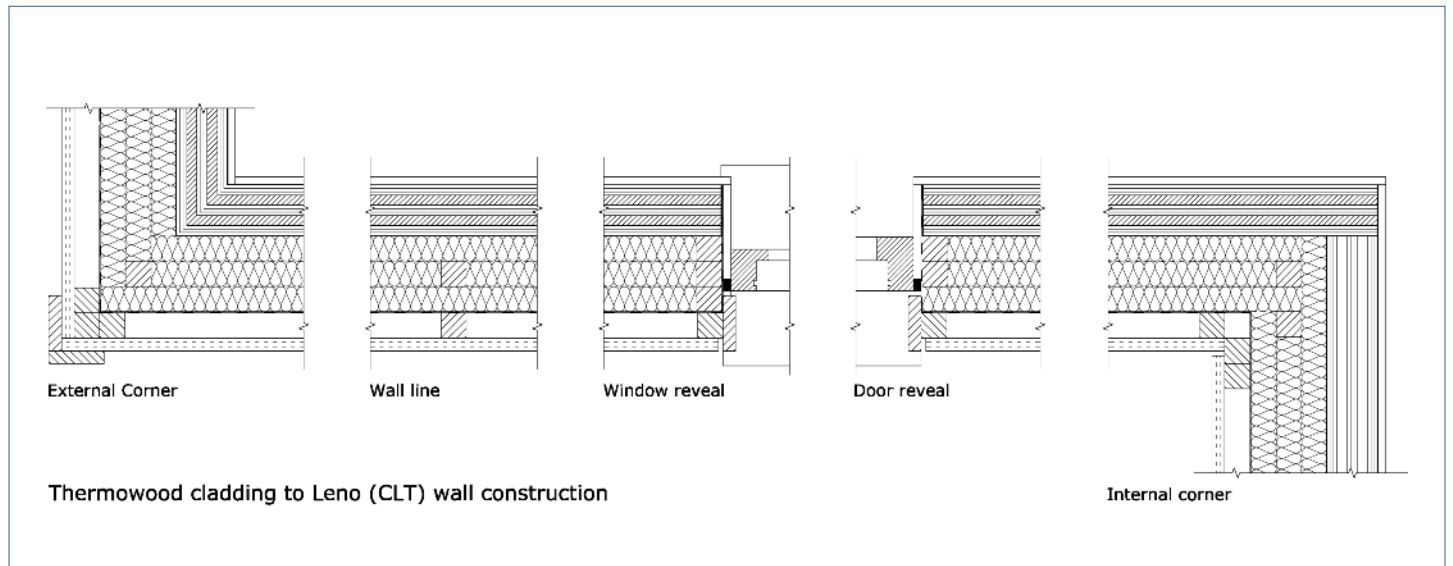

TYPICAL LAYOUT - HORIZONTAL BOARDS

When designing horizontal ThermoWood cladding, the battens must be coincident with the timber studs and these are usually at either 400mm or 600mm centres.

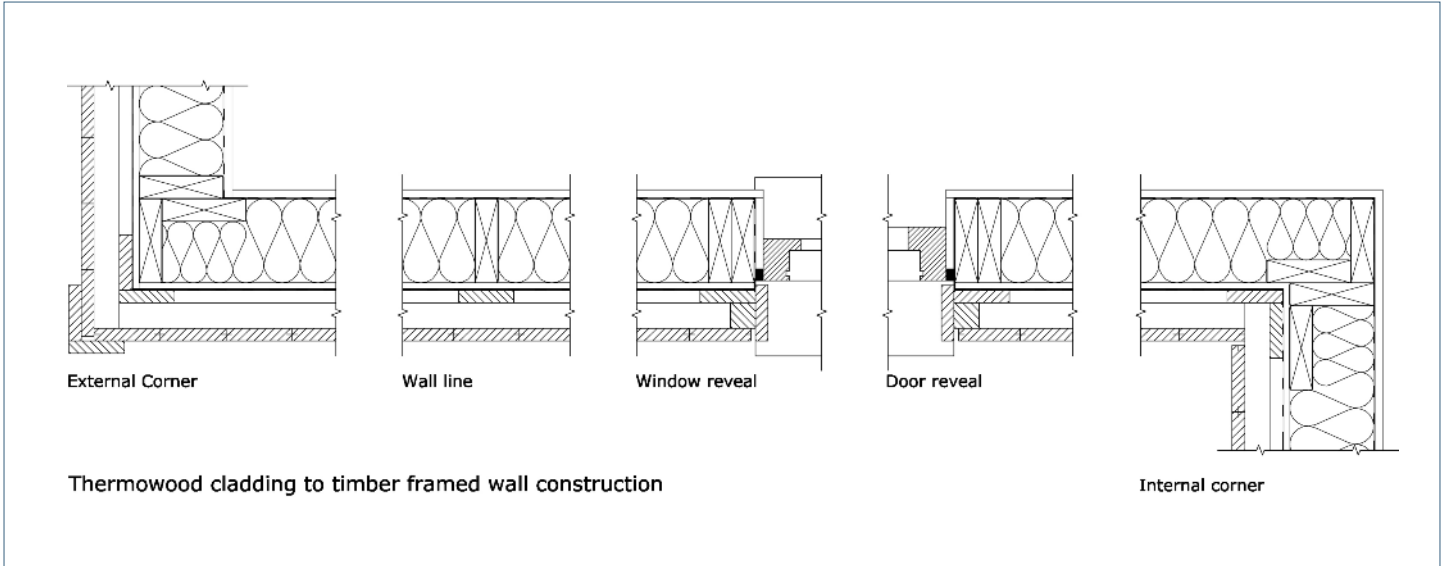

TYPICAL LAYOUT - VERTICAL BOARDS

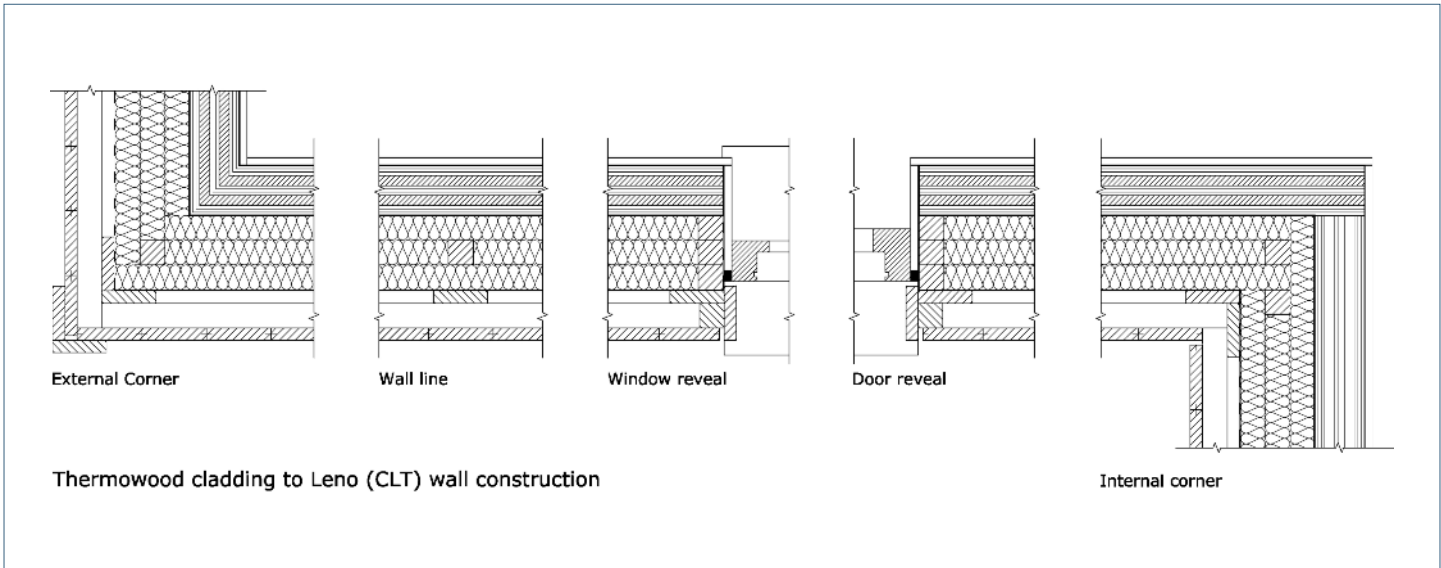

TYPICAL LAYOUT - VERTICAL BOARDS

TYPICAL GENERAL LAYOUTS

MASONRY WALLS

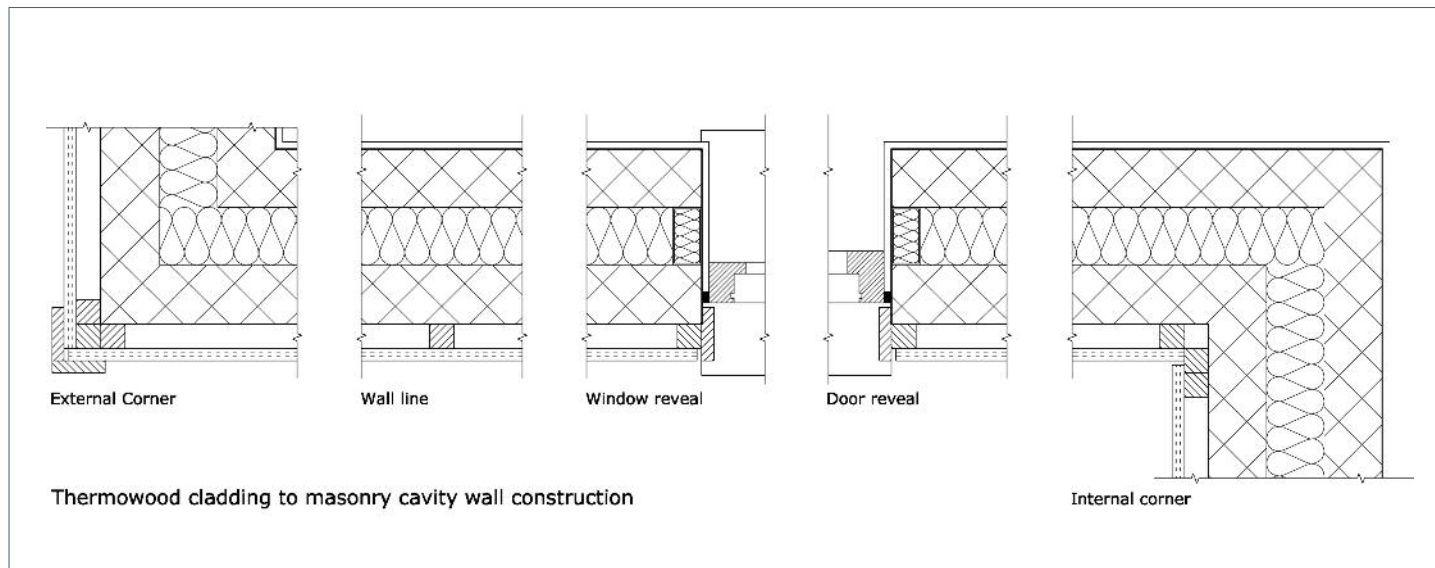

TYPICAL LAYOUT - HORIZONTAL BOARDS

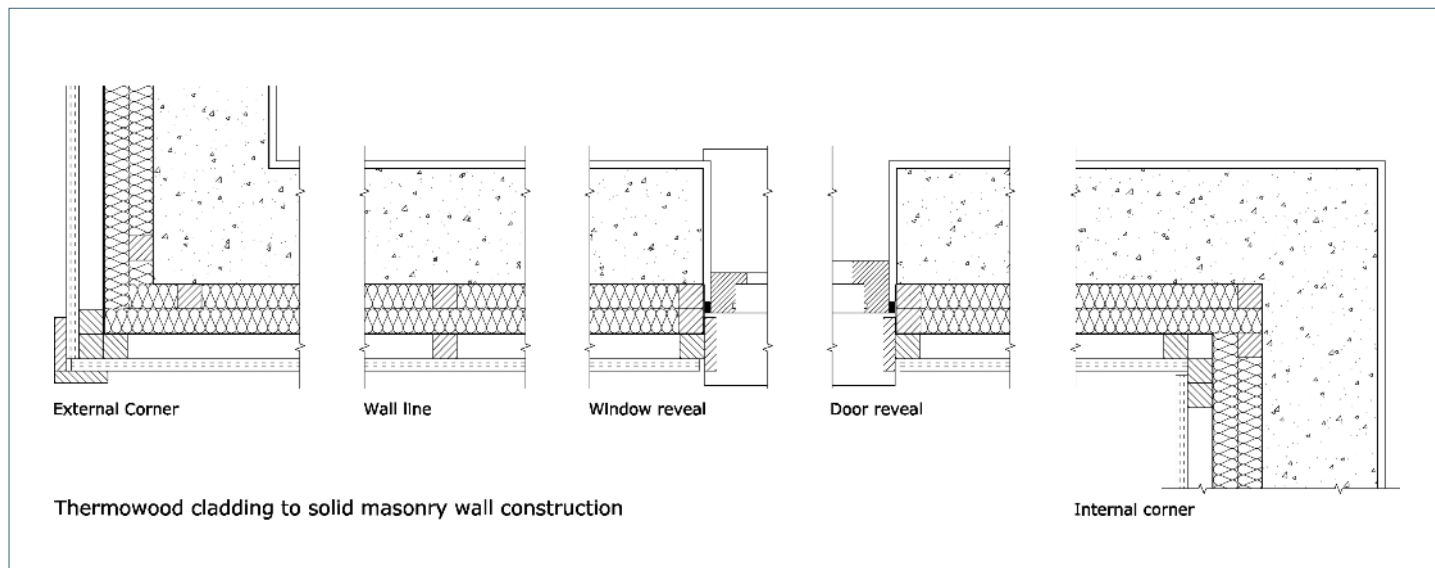

TYPICAL LAYOUT - HORIZONTAL BOARDS

When timber cladding is fixed to masonry, 42mm thick ThermoWood battens should be used (38mm if treated softwood), in order to ensure that the board-fixing nails do not have to be driven into the masonry. 21mm thick ThermoWood battens (or 19mm if treated softwood), can be used as vertical counter battens.

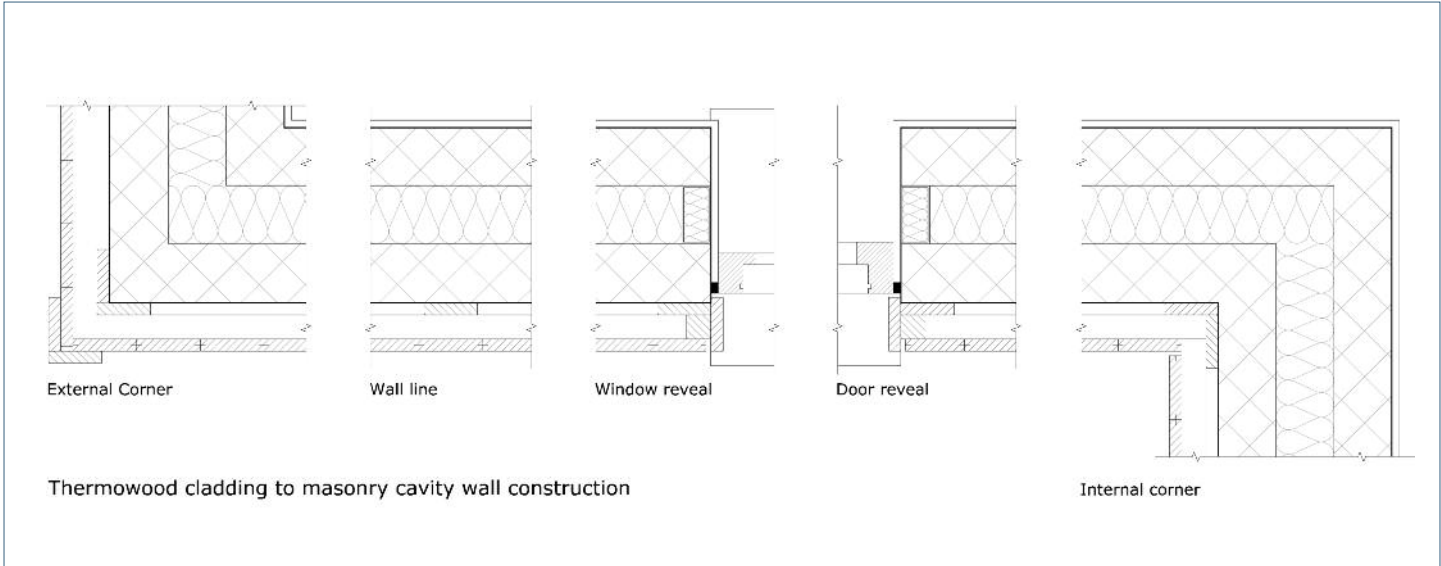

TYPICAL LAYOUT - VERTICAL BOARDS

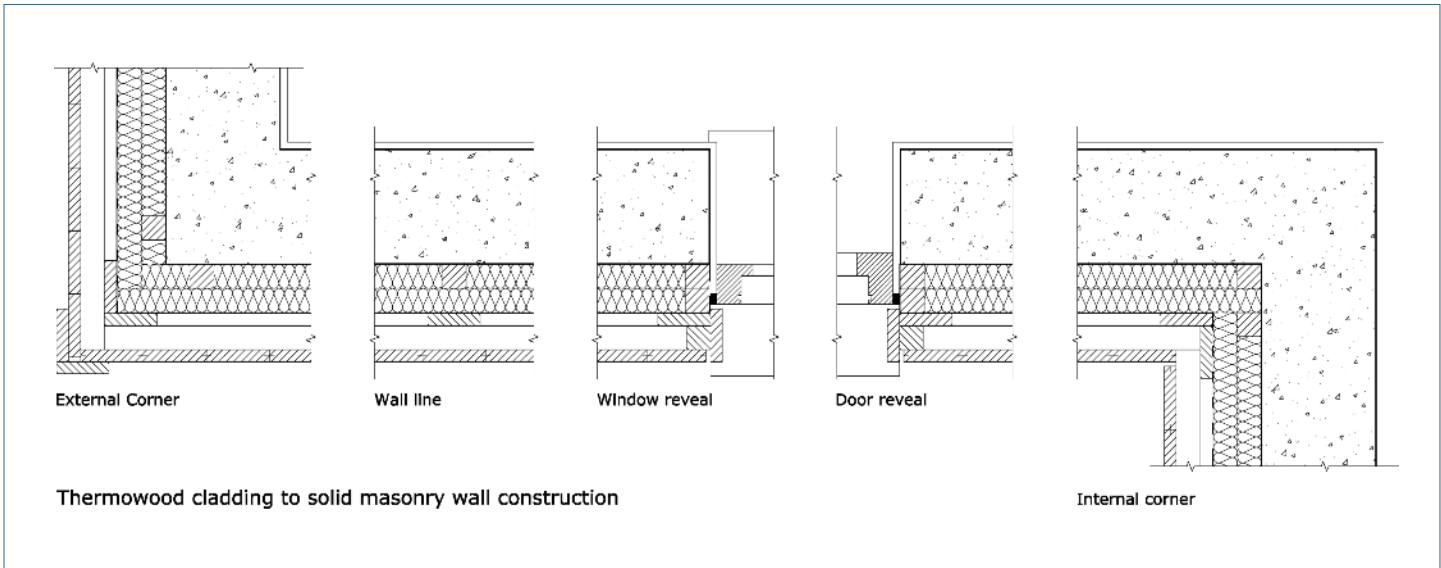

TYPICAL LAYOUT - VERTICAL BOARDS

VENTILATION AND GROUND CLEARANCE

OPENINGS

Most areas of timber cladding will either contain openings for windows or doors, or be contained within a dimensional framework determined by areas of glazing or a regular pattern of windows. Ideally, any openings should be in multiples of the chosen board width to avoid the need to notch or split boards.

Having to notch or split boards around openings can lead to poor appearance. It is also important to consider the flashing, sills, cavity trays and damp proof courses around any openings to ensure that water is drained away to the outside of the wall and any exposed end grain is protected.

TYPICAL DETAIL OF VENTILATION CAVITY INCORPORATING AN INSECT MESH

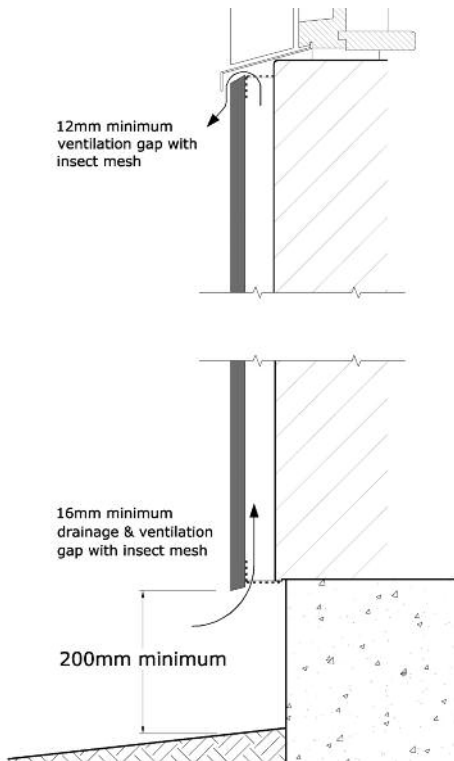

SILL AND GROUND LEVEL SECTIONS

MAINTAINING A DRAINED AND VENTILATED CAVITY

If vertical boards are fixed to horizontal battens it will be necessary to introduce vertical counter battens behind the horizontal battens to provide drainage and air circulation. If the horizontal battens are to be fixed to counter battens, the battens must be of sufficient thickness to span between the counter battens, i.e. 42mm thick ThermoWood battens (38mm if treated softwood).

To avoid infestation by insects, any openings at the top or bottom of close jointed or board-on-boards should be protected by an insect mesh. If open jointed boards are to be used, it may be necessary to add a full insect mesh membrane between the boards and battens.

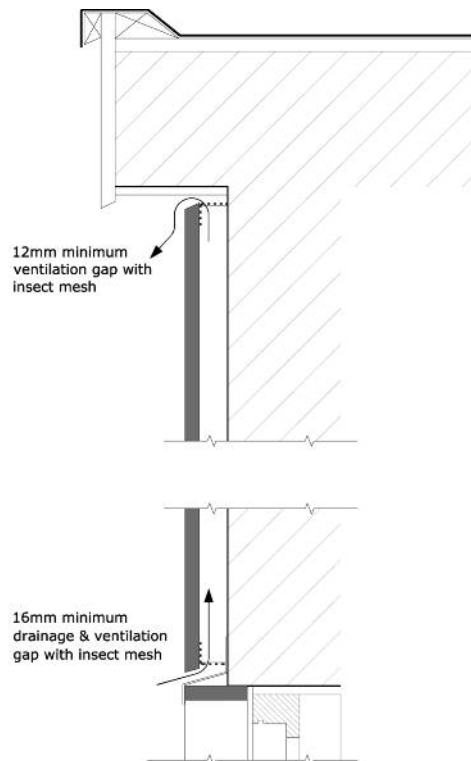

EAVES LEVEL AND HEAD SECTIONS

CORNER DETAILS

There are a number of different external and internal corner details that can be designed using standard ThermoWood components, whether attached to timber frame, masonry, or externally-insulated walls.

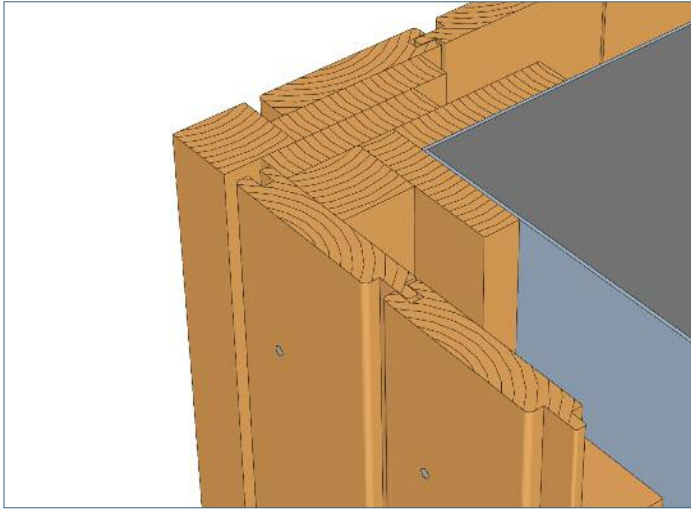

CHANNEL VERTICAL CLADDING CORNER BATTEN

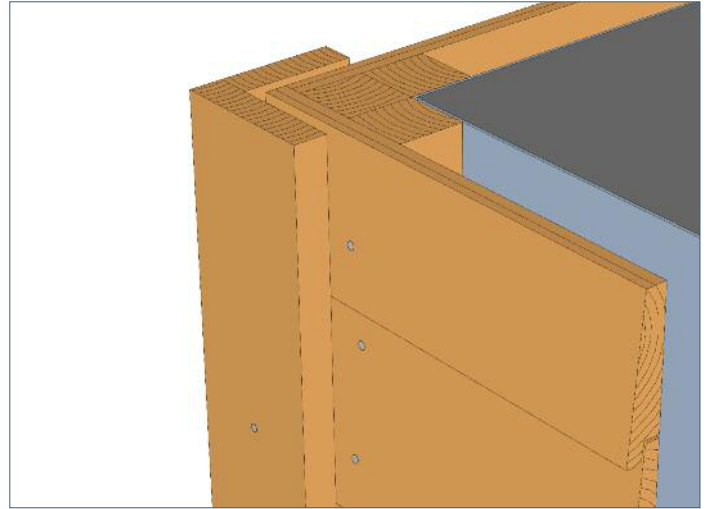

TAPERED HORIZONTAL CLADDING COVERED CORNER

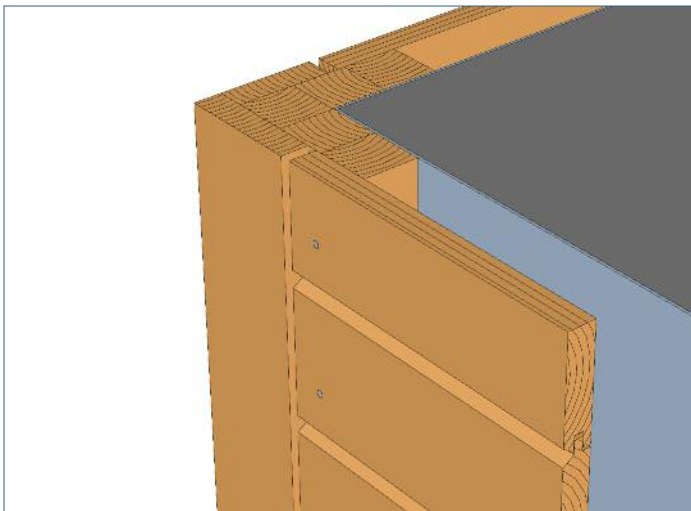

PMV HORIZONTAL CLADDING FLUSH CORNER

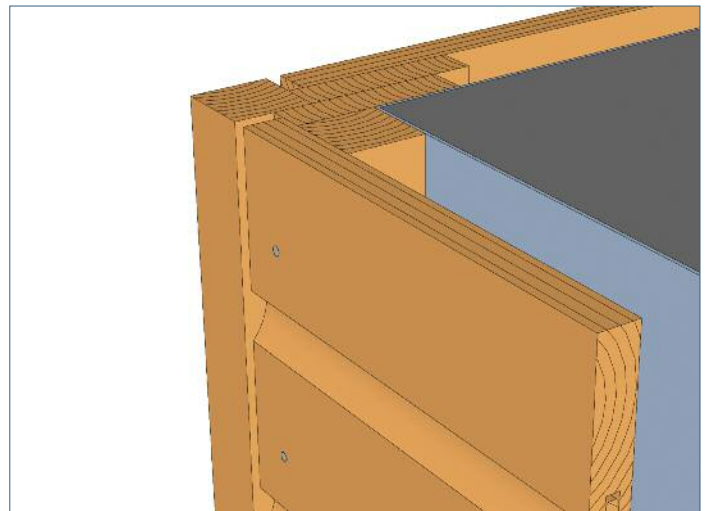

SHIPLAP SQUARE BATTEN CORNER

Other corner details are available.

To discuss your technical requirements in more detail,
email uk@metsagroup.com
or call 0800 00 44 44

INSTALLATION

FIXINGS

It is recommended to use a pneumatic nailer with a facility to adjust the pressure.

The nail should penetrate so that the head sits flush with the cladding surface.

Typically 2.1mm or 2.5mm is the recommended nail diameter when using a pneumatic nailer and improved nails.

The use of improved nails (annular ring shank nails) is recommended, to improve nail holding strength and to be able to use thinner nails and avoid the risk of splitting.

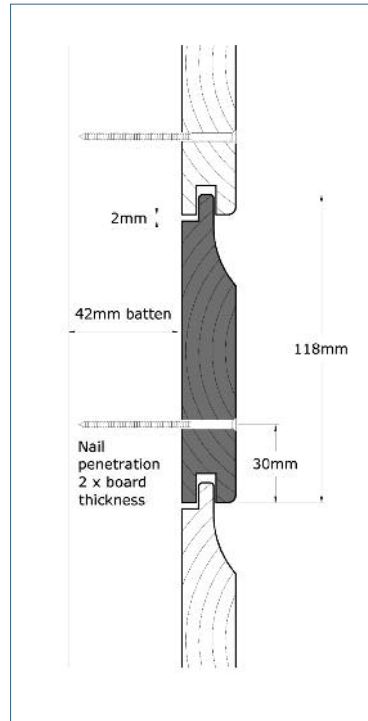

NAILING POSITION - T&G SHIPLAP BOARDS

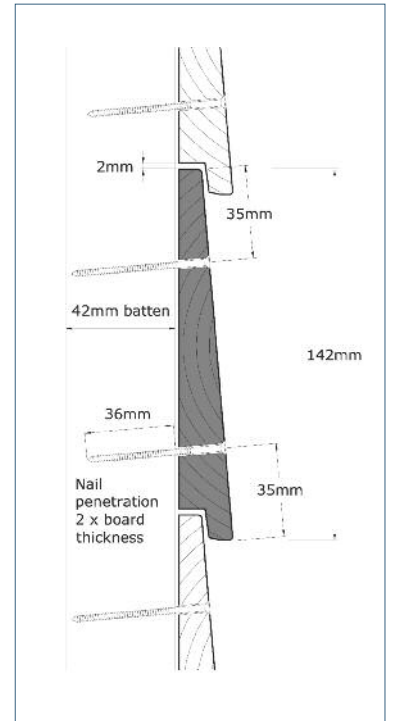

NAILING POSITION - TAPERED BOARDS

NAIL TYPES

Stainless steel nails should be used to fix ThermoWood, because plated nails can be damaged during fixing and can deteriorate when exposed to moisture, staining the area around the nail head.

A less visible lower gauge nail can be used but lower pull-through strength should be noted, and additional fixings may be required. 'Small head' or 'siding nails' are suitable for ThermoWood but 'round-head' nails offer greater holding power.

'Losthead' pins are not recommended.

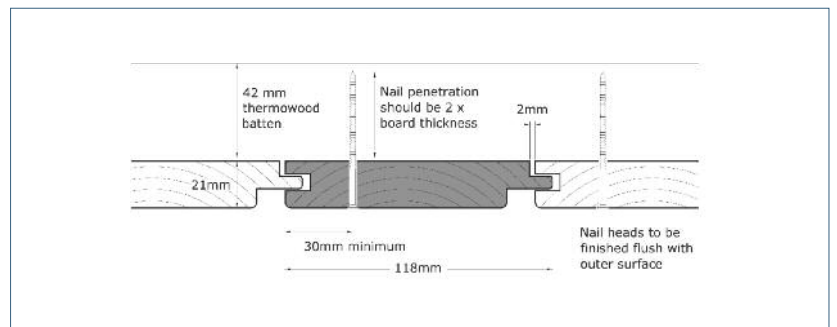

NAILING POSITION - CHANNEL BOARDS

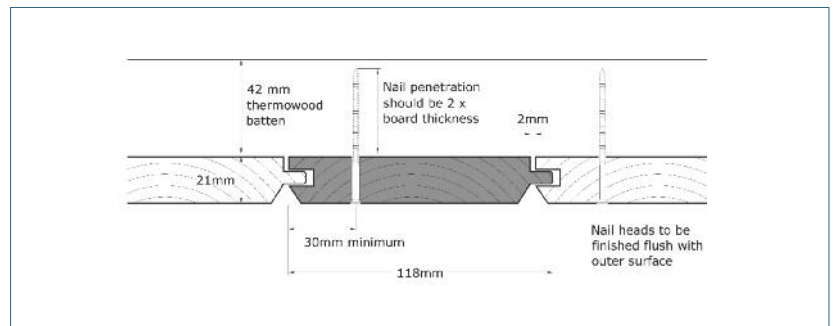

NAILING POSITION - PMV BOARDS

1. Using a hammer increases the risk of splitting or indentation due to hammer contact with the wood.
2. Do not nail on knots whether fixed manually or by nail gun.
3. If tongue and grooved boards are to be used, a 2mm clearance gap should be allowed between the tongue and groove of the joint and between board edges. The gap is required to allow for any potential movement due to moisture uptake. A similar gap should be left between the edges of tapered cladding boards.
4. If screws are to be used, pilot drilling is always recommended.
5. Secret nailing with single nails through the tongue should be avoided for tongue and grooved ThermoWood boards because of the risk of the tongue splitting. Any concealed nails should be limited to the rebated part of the board in the T&G shiplap or channel profile. Risk of splitting can be further reduced by drilling pilot holes.
6. Nail fixing should be at least 30mm from the ends and 30mm from the edges of the boards. Always apply the edge and end distance rules to avoid splitting. If forced to fix under the recommended edge and end distances, always drill nail holes before fixing to prevent splitting.
7. Double fixings for wider boards should preferably be located as close as possible to the quarter points in the board width, although the actual position of the fixings may be determined by the board profile. It is important that where boards are overlapped, or in a board-on-board pattern, that the nails fixing the outer boards do not penetrate the inner boards. Overlap between outer and inner boards on board-on-board cladding should be minimum 18mm.
8. Cladding boards 120mm wide or above should be double nailed but boards 119mm, or under, can be fixed with one nail. Single nails in the face of the board should be located in the lower part of the board.
9. In conditions where cladding boards are exposed to heavy wind loading, all board widths should be double nailed.
10. Where boards are butt-jointed, the junction should always occur over a double width of batten.



SURFACE TREATMENT AND MAINTENANCE

SURFACE TREATMENT

ThermoWood is a durable product that will last for many years without applying any surface coating. The natural effect of weathering and exposure to sunlight on unfinished boards will, however, cause loss of colour, increased raised grain, surface cracking and a higher risk of surface algae growth.

Pigmented translucent stain can give protection against UV light and consequent bleaching of the wood, while retaining the natural ThermoWood appearance. The most commonly used coating is a translucent stain containing a brown pigment close to the original ThermoWood colour. The finish is usually slightly darker than the natural colour of ThermoWood.

Only vapour permeable, either translucent or opaque 'Low-build' stains recommended for exterior use should be used.

Different treatments will have different maintenance intervals. The more pigment used, the longer the maintenance-free period. See coatings manufacturer's instructions.

It is recommended to apply one coat of finish to all faces before installation and apply additional coats once the boards are installed. Sealing of end grain with the finish is important if the board ends are to be tight butted. It will reduce the potential for any moisture ingress and possible staining around the end grain.

The finish should be applied on ThermoWood in accordance with the recommendations of the coatings manufacturer, with strict attention given to proper coverage instructions, temperature and weather conditions at the time of coating and any other specific requirements. Surface must be clean and dry when treated.

MAINTENANCE

The environment and climate have a crucial impact on the service life of surface coatings, and UV light and moisture are the major factors affecting surface coatings. This could mean South-facing elevations need more regular maintenance than those facing North. In addition, buildings exposed to prevailing winds may require more maintenance than those more protected, due to the abrasive factor of the wind-blown moisture. Always refer, where possible, to the coatings manufacturer's specific instructions of maintenance of any finish.

To ensure maximum performance of any coating, the surface should be cleaned and checked regularly. If defects occur in the coating it is usually a sign of a structural weakness, which should be repaired immediately.

Unfinished ThermoWood will also benefit from occasional washing with a mild detergent solution to remove surface growth or dirt.

Annual inspection is advisable in order to spot any faults that could lead to possible serious damage. Mechanical damage may require immediate repair.



MAINTENANCE CHECK LIST FOR METSÄ WOOD THERMOWOOD CLADDING

- **FIXINGS OF CLADDING BOARDS AND TRIMS**
Fix loose cladding boards and trims. Replace any damaged boards.
- **DIRT ON THE SURFACE**
Wash down to remove contamination due to weathering or surface growth and any loose particles.
- **COATING AND REAPPLICATION**
Loose coating material or dirt should be removed by washing, sanding, scraping or brushing only with a non-metallic brush. Treat surface with one or more coats. Use the same translucent or opaque wood stain as initial application. Always follow coatings manufacturer's instructions.
- **RAIN DAMAGE**
Clean any accumulation of leaves and deposits from the gutters so that there is no overflow onto the cladding, or where water can get behind the cladding boards and cause deterioration. Make sure that water does not stand on horizontal surfaces in close proximity to cladding.
- **FLASHINGS**
Any flashing above cladding should discharge water away from the surface of the cladding, to avoid local staining of the wood and possible leakage into the cavity.

WORKING WITH METSÄ WOOD THERMOWOOD® PRODUCTS

GENERAL WORKING WITH THERMOWOOD PRODUCTS

ThermoWood cuts like untreated pine. However, due to the dry nature of ThermoWood, the saw dust is lighter and finer. Because of the more brittle nature of ThermoWood, care should be taken not to apply unnecessary impact stresses as these can result in splitting and damage.

HEALTH AND SAFETY

There is no major difference in health and safety aspects of ThermoWood compared to normal softwood species. There are still two detectable differences: the smell of the material and the dust produced when processing ThermoWood.

ThermoWood has a smoke-like smell, which arises from chemical compounds called furfurals. The volatile organic compound (VOC) emissions from ThermoWood are only a fraction of those from normal pine.

There are no toxic or harmful components in ThermoWood, but if wood splinters penetrate the skin they should be removed as soon as possible.

ThermoWood dust has a smaller particle size than normal softwoods. It is comparable to MDF (although lower density) or hardwood dust. Dust can cause problems for people suffering from asthma. Because of the reasons mentioned above, special attention should be paid to the dust removal system. If dust extraction systems are not available, dust masks should be used.

HANDLING AND STORAGE

When in storage ThermoWood should be laid flat with sufficient support to eliminate bowing (recommended maximum distance of 600mm between supports).

To minimise the potential for degradation, store ThermoWood out of ground contact and in dry conditions.

Where gluing and/or surface treatment is taking place, material should be acclimatised to the moisture content and temperature as required by the manufacturer's recommendations.

WASTE HANDLING

ThermoWood is a natural wood product and has no chemical additives. When not glued or painted, ThermoWood waste can be handled as any other untreated wood waste.

USE CLASSIFICATIONS

European Standard for the assessment of Use classes:
Application to solid wood (source EN 335-1, EN 335-2).

USE CLASS 1

Where wood is under cover, fully protected from weather and not exposed to wetting.

In this environment, the moisture content of solid wood is such that the risk of attack by surface moulds or by staining or wood destroying fungi is insignificant, i.e. the wood shall have a moisture content of maximum 20% in any part for practically the whole of its service life. However, attack by wood-boring insects, including termites, is possible although the frequency and importance of the insect risk depends on the geographic region.

USE CLASS 2

Where wood is under cover and fully protected from the weather but where high environmental humidity can lead to occasional but not persistent wetting.

In this environment the moisture content of solid wood occasionally exceeds 20% either in the whole or only in part of the component and thus allows attack by wood destroying fungi. For timber whose use includes a decorative function, discolouration can also occur as a result of the growth of surface moulds and staining fungi.

USE CLASS 3

Where wood is not covered and is not in contact with the ground. It is either continually exposed to the weather or is protected from the weather but subject to frequent wetting.

In this environment, solid wood can be expected to have a moisture content above 20% frequently, and thus it will often be liable to attack by wood destroying fungi.

For timber whose use includes a decorative function, discolouration can occur as a result of the growth of surface moulds and staining fungi.

USE CLASS 4

Where wood or wood-based product is in contact with the ground or fresh water and is permanently exposed to wetting.

In this environment, solid wood can have a moisture content above 20% permanently and is liable to attack by wood destroying fungi. Termites can be a problem in certain geographic regions. Additionally, the above ground (or above water) portion of certain components, for example fence posts, may be attacked by wood-boring beetles.

USE CLASS 5

Where wood is permanently exposed to salt water.

**IN NORMAL CONDITIONS
EXTERNAL CLADDING IS EXPOSED
TO USE CLASS 2 OR 3.**

For more information visit www.metsawood.co.uk or call our technical team on 0800 00 44 44.

Metsä Wood is a wood products company delivering service-oriented solutions developed in collaboration with its customers. Its premium solutions are based on ecological, high quality Nordic wood as a raw material.

Wood is the only building material that is truly renewable, if well managed. Forest certification schemes give assurance that the timber is legal and from sustainable sources. Metsä Wood sources certified timber over uncertified and is an approved Chain of Custody supplier.

MW0187 Aug 13.

The photographs in this brochure are for illustration purposes only.

Metsä Wood reserves the right to change the range without notice.

Every effort has been made to ensure that colours are accurate within the limitations of natural lighting conditions and the four colour printing process.

METSÄ WOOD

Telephone: 0800 00 44 44
Email: uk@metsagroup.com
www.metsawood.co.uk

