

Merriott

DESIGN RADIATORS

BATHROOM RADIATORS TECHNICAL INFORMATION



CONTENTS

Bathroom Radiator Specifications	2
Bathroom Radiators Overview	3
QRT Heat emissions/data charts & Applications	4
QRC Heat emissions/data charts & Applications	5
ARES Heat emissions/data charts & Applications	6
VENUS Heat emissions/data charts & Applications	7
CRYSTAL STRAIGHT Heat emissions/data charts & Applications	8
CRYSTAL CURVED Heat emissions/data charts & Applications	9
FEATURES & OPTIONS:	
Dip tubes	10
Dual Adaptor Kit	10
Applications – bracket details	11
Correction factors	12
Resistance diagram	13
Resistance	14
How to Order	15

Bathroom Radiator Specifications

Paint

Merriott Radiators uses a painting process developed for the automobile industry. In pre-treatment, the radiators go through a series of washes which degrease the steel. An iron phosphate rinse passivates the surface prior to painting. The primer coat is applied by immersion in an electrophoretic bath to give total cover of the bare steel and maximum corrosion protection. This coat is baked at 200°C. The durable topcoat (epoxy polyester powder) is electrostatically applied and stove enamel baked at 200°C. This process is monitored to ensure continuous achievement of optimum adhesion, opacity and gloss levels

Colour

Our standard finish for the QRT and the QRC is semi-gloss RAL 9016 (white) in epoxy polyester powder. The Venus, Ares and Crystal bathroom radiators are available in chrome.

All chrome bathroom radiators are polished to a high quality finish.

Outputs

All Merriott Radiators are manufactured and tested in accordance with BS EN 442.

Sizing & Heat Emissions

Merriott Radiators bathroom radiators offer emissions from 200 Watts to 1400 Watts at $\Delta T 50^{\circ}\text{C}$

Height

The heights range from 800mm to 1800mm for the QRT and the QRC. The heights range from 688mm to 1720mm for the Venus, Ares. The heights range from 730mm to 1730mm for the Crystal bathroom radiators.

Width

The Width ranges from 500mm to 750mm for the QRT, the QRC, the Venus, and the Ares bathroom radiators. The Width ranges from 450mm to 600mm for the Crystal bathroom radiators.

Warranty

Merriott Radiators Bathroom radiators are guaranteed for a period of ten years in respect of defective materials and workmanship. In order for the warranty to be valid, designers and installers must observe and adhere to **BS EN 12828:2003**. Heating systems in buildings – design for water based heating systems and installers must adhere to **BS EN 14336:2004**. Heating system in buildings – installation and commissioning of water based heating systems. In addition Merriott Radiators recommends that designers and installers observe and adhere to the British Standard code of practice for the treatment of water in domestic hot water central heating systems and **BS 7593:2006**, the use of corrosion inhibitor is recommended for all applications, failure to observe this may result in the invalidation of warranty.

Dimensional Tolerances

Dimensional Tolerances are in accordance with **EN442**.

Materials

Bathroom radiators are made from 1.25mm and 1.5mm thick steel tubes.

Operating Pressures

Each bathroom radiator is tested to 1.3 times its maximum allowable working pressure. The maximum allowable working pressure for all the towel radiators is 5.38 Bar

Connections

Standard connections on all bathroom radiators are 4 x 1/2" (15mm) BSP connections at E, F, G and H.

Electric Power Option

All bathroom radiators can be fitted with an electrical element and can be used when your central heating is off. This enables you to have warm dry towels without the need to heat the rest of your house.

Bathroom Radiators Overview

QRT

Available in white as Standard

3xHeights:
800mm, 1200mm and 1800mm.

3xWidths:
500mm, 600mm and 750mm.



QRC

Available in white as Standard

3xHeights:
800mm, 1200mm and 1800mm.

3xWidths:
500mm, 600mm and 750mm.

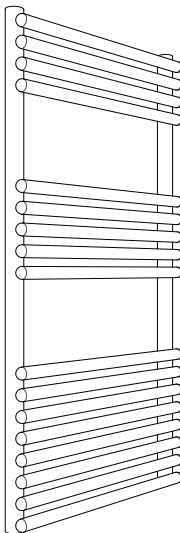

ARES

Available in both white and chrome

3xHeights:
688mm, 1118mm and 1720mm.

3xWidths:
500 mm, 600mm, 750 mm

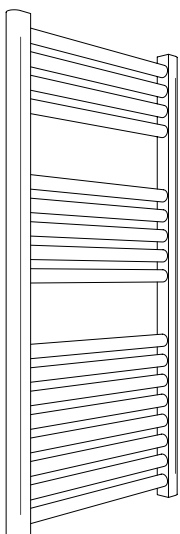

VENUS

Available curved in both white and chrome

3xHeights:
688mm, 1118mm and 1720mm.

3xWidths:
500 mm, 600mm, 750 mm

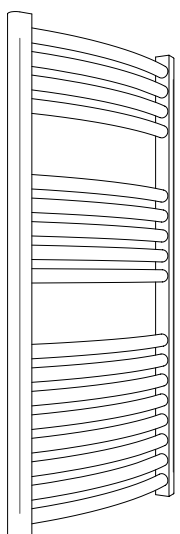

Crystal Straight

Available in both white and chrome

3xHeights:
730mm, 1160mm, 1730mm.

2xWidths:
450mm, 600mm.



Crystal Curved

Available curved in both white and chrome

3xHeights:
730mm, 1160mm, 1730mm.

2xWidths:
450mm, 600mm.

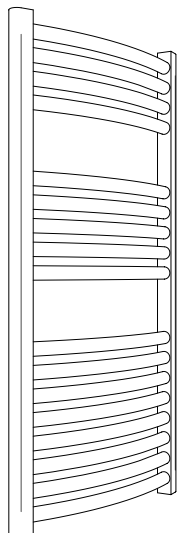

Heat Emissions / Data Charts

QRT	800mm			1200mm			1800mm		
Width	500	600	750	500	600	750	500	600	750
Dry weight (kgs)	9.3	10.7	12.9	13.8	16	19.3	22	25.6	30.9
Water content (L)	3.3	3.6	4	4.8	5.2	6	7.7	8.5	9.8
Number of elements	16	16	16	24	24	24	39	39	39
	Output (Watts)			Output (Watts)			Output (Watts)		
$\Delta T50$	403	483	604	589	707	884	938	1126	1408
$\Delta T56$	463	555	694	676	811	1015	1077	1292	1615

QRT

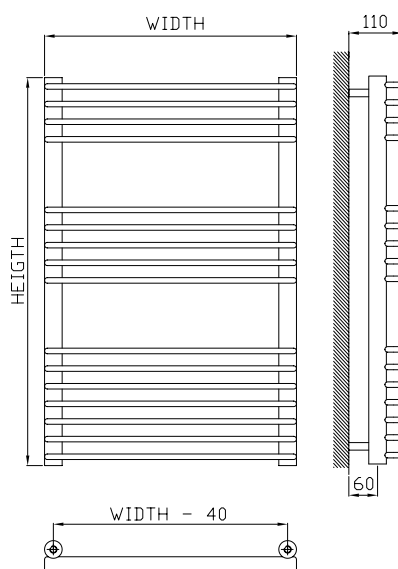

Electrical Elements			
Height	800mm	1200mm	1800mm
Element	200 Watts	300 Watts	500 Watts

All of the above Bathroom Radiators are available from stock
 These Bathroom Radiators must only be used on an indirect or closed heating system

Heat Emissions / Data Charts

QRC		800mm			1200mm			1800mm		
Width		500	600	750	500	600	750	500	600	750
Dry weight (kgs)		9	10.4	12.6	13.1	15.7	18.9	20.8	24	30
Water content (L)		3.6	4	4.6	5.4	6	6.9	8.1	9	10.5
Number of elements		16	16	16	24	24	24	37	37	37
		Output (Watts)			Output (Watts)			Output (Watts)		
$\Delta T50$		367	441	551	536	644	804	811	973	1217
$\Delta T56$		420	504	630	614	737	922	931	1117	1396

QRC

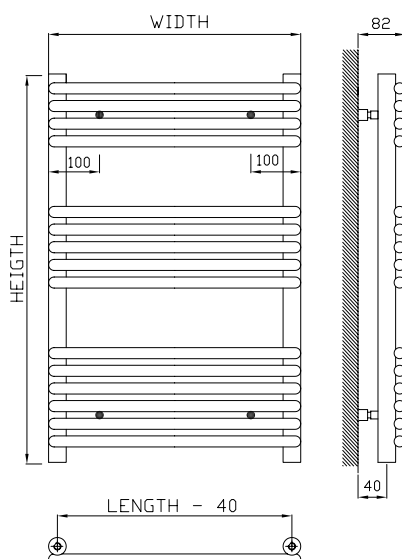

Electrical Elements			
Height	800mm	1200mm	1800mm
Element	200 Watts	300 Watts	500 Watts

All of the above Bathroom Radiators are available from stock
 These Bathroom Radiators must only be used on an indirect or closed heating system

Ares

Heat Emissions / Data Charts & Applications

Ares	
Width	
Dry weight (kgs)	
Water content (L)	
Number of elements	
Output (Watts)	
ΔT50	
ΔT56	

688mm			
500	600	750	
6	6.9	8.2	
3.2	3.6	4.4	
14	14	14	
Output (Watts)			
349	405	488	
399	467	563	

1118mm			
500	600	750	
9.4	10.9	13	
5.1	5.8	6.8	
22	22	22	
Output (Watts)			
526	617	753	
566	711	865	

1720mm			
500	600	750	
14.5	16.7	20	
7.8	8.9	10.6	
34	34	34	
Output (Watts)			
818	957	1166	
938	1098	1337	

Ares Chrome	
Width	
Dry weight (kgs)	
Water content (L)	
Number of elements	
Output (Watts)	
ΔT50	
ΔT56	

688mm			
500	600	750	
6	6.9	8.2	
3.2	3.6	4.3	
14	14	14	
Output (Watts)			
219	253	304	
252	292	351	

1118mm			
500	600	750	
9.4	10.9	13	
5.1	5.8	6.8	
22	22	22	
Output (Watts)			
346	408	500	
399	470	576	

1720mm			
500	600	750	
14.5	16.7	20	
7.8	8.9	10.6	
34	34	34	
Output (Watts)			
538	636	783	
620	733	902	

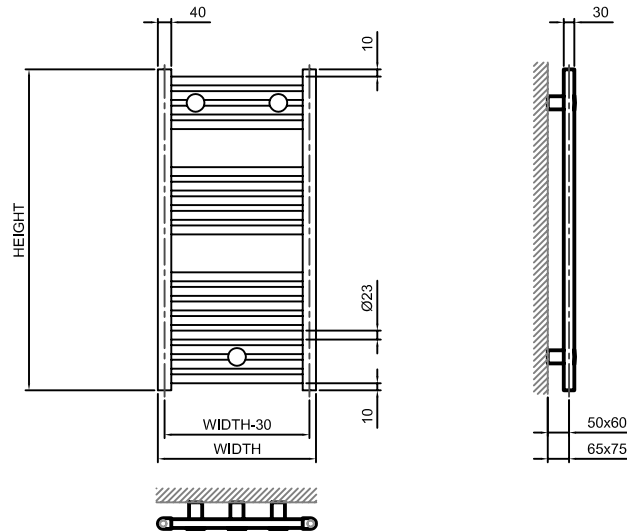

Element table for Ares			
Height/Width	688mm	1118mm	1720mm
500mm	300 Watt	400 Watt	400 Watt
600mm	400 Watt	700 Watt	700 Watt
750mm	700 Watt	1000 Watt	1000 Watt

Element table for Ares Chrome			
Height/Width	688mm	1118mm	1720mm
500mm	-	-	300 Watt
600mm	400 Watt	400 Watt	600 Watt
750mm	600 Watt	800 Watt	1000 Watt

Venus

Heat Emissions / Data Charts & Applications

Venus
Width
Dry weight (kgs)
Water content (L)
Number of elements
Output (Watts)
ΔT50
ΔT56

688mm		
500	600	750
6	6.9	8.3
3.2	3.7	4.4
14	14	14
Output (Watts)		
349	405	488
399	467	563

1118mm		
500	600	750
9.5	11	13.2
5.1	5.8	6.9
22	22	22
Output (Watts)		
526	617	753
566	711	865

1720mm		
500	600	750
14.6	16.8	20.3
7.9	9	10.7
34	34	34
Output (Watts)		
818	957	1166
938	1098	1337

Venus Chrome
Width
Dry weight (kgs)
Water content (L)
Number of elements
Output (Watts)
ΔT50
ΔT56

688mm		
500	600	750
6	6.9	8.3
3.2	3.7	4.4
14	14	14
Output (Watts)		
219	253	304
252	292	351

1118mm		
500	600	750
9.5	11	13.2
5.1	5.8	6.9
22	22	22
Output (Watts)		
346	408	500
399	470	576

1720mm		
500	600	750
14.6	16.8	20.3
7.9	9	10.7
34	34	34
Output (Watts)		
538	636	783
620	733	902

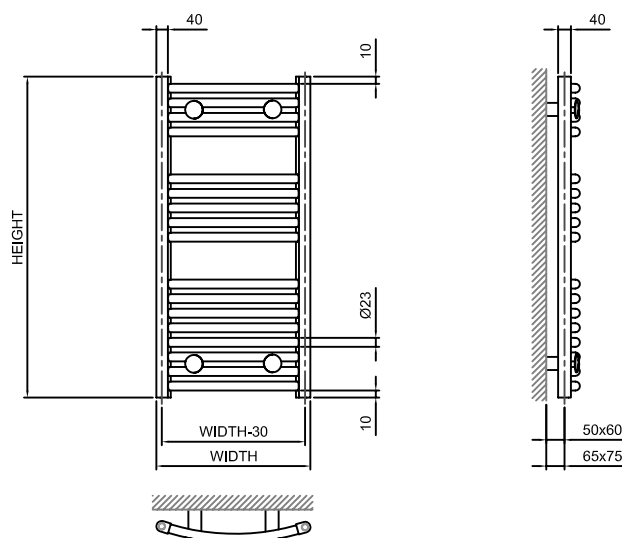

Element table for Venus			
Height/Width	688mm	1118mm	1720mm
500mm	300 Watt	400 Watt	400 Watt
600mm	400 Watt	700 Watt	700 Watt
750mm	700 Watt	1000 Watt	1000 Watt

Element table for Venus Chrome			
Height/Width	688mm	1118mm	1720mm
500mm	-	-	300 Watt
600mm	400 Watt	400 Watt	600 Watt
750mm	600 Watt	800 Watt	1000 Watt

Crystal Straight

Heat Emissions / Data Charts & Applications

Crystal	730mm		1160mm		1730mm	
Width	450	600	450	600		600
Dry weight (kgs)	4.8	5.85	7.88	9.54	-	13.7
Water content (L)	2.9	3.54	4.74	5.38	-	8.47
Number of elements	15	15	25	25	-	36
	Output (Watts)		Output (Watts)		Output (Watts)	
ΔT50	313	397	490	643	-	930
ΔT56	363	461	569	747	-	1079

Crystal Chrome	730mm		1160mm		1730mm	
Width	450	600	450	600		600
Dry weight (kgs)	4.8	5.85	7.88	9.54	-	13.7
Water content (L)	2.9	3.54	4.74	5.38	-	8.47
Number of elements	15	15	25	25	-	36
	Output (Watts)		Output (Watts)		Output (Watts)	
ΔT50	203	265	327	429	-	620
ΔT56	236	307	379	498	-	720

Crystal Straight

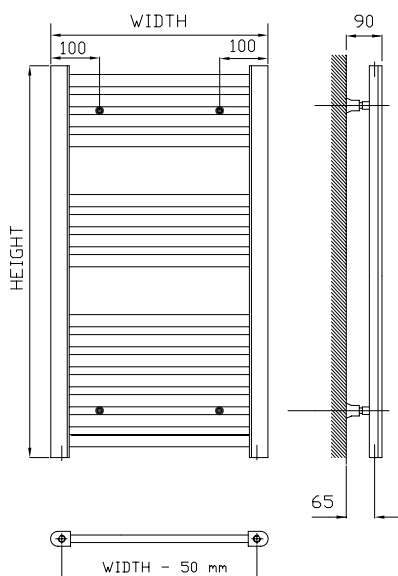

Radiator Height	Element Order Code	Output Watts
All Heights	EE002	200

Crystal Curved

Heat Emissions / Data Charts & Applications

Crystal	730mm		1160mm		1730mm	
Width	450	600	450	600		600
Dry weight (kgs)	4.88	5.93	8.01	9.67	-	13.88
Water content (L)	2.94	3.58	4.81	5.87	-	8.57
Number of elements	15	15	25	25	-	36
	Output (Watts)		Output (Watts)		Output (Watts)	
ΔT50	327	380	533	675	-	959
ΔT56	380	414	618	784	-	1113

Crystal Chrome	730mm		1160mm		1730mm	
Width	450	600	450	600		600
Dry weight (kgs)	4.88	5.93	8.01	9.67	-	13.88
Water content (L)	2.94	3.58	4.81	5.87	-	8.57
Number of elements	15	15	25	25	-	36
	Output (Watts)		Output (Watts)		Output (Watts)	
ΔT50	-	276	355	450	-	640
ΔT56	218	320	412	505	-	742

Crystal Curved

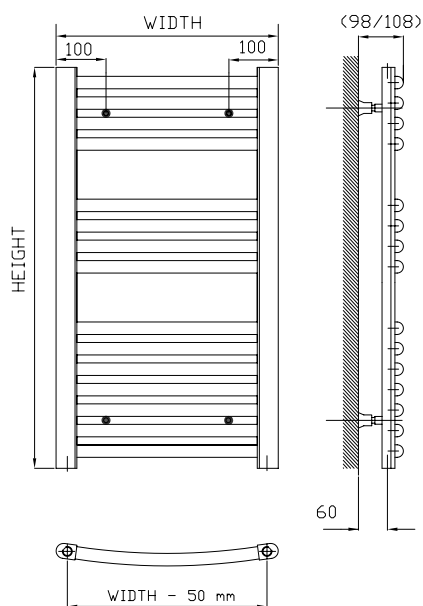

Radiator Height	Element Order Code	Output Watts
All Heights	EE002	200

Features & Options

Dip Tubes

Standard connections on all bathroom radiators are 4 x 1/2" (15mm) connections at **E, F, G** and **H**. Normal application means the radiator is connected up at the **E** and **F** connection, with 2 x 1/2" (15mm) airvents at the **G** and **H** locations. It is possible, using a dip tube, to pipe up the unit from the top (i.e. at **G** and **H**) to ensure overall water distribution. These can be inserted into the stock product and can be retrofit if required.

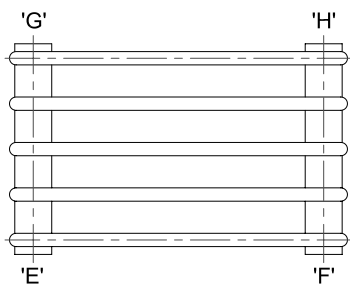
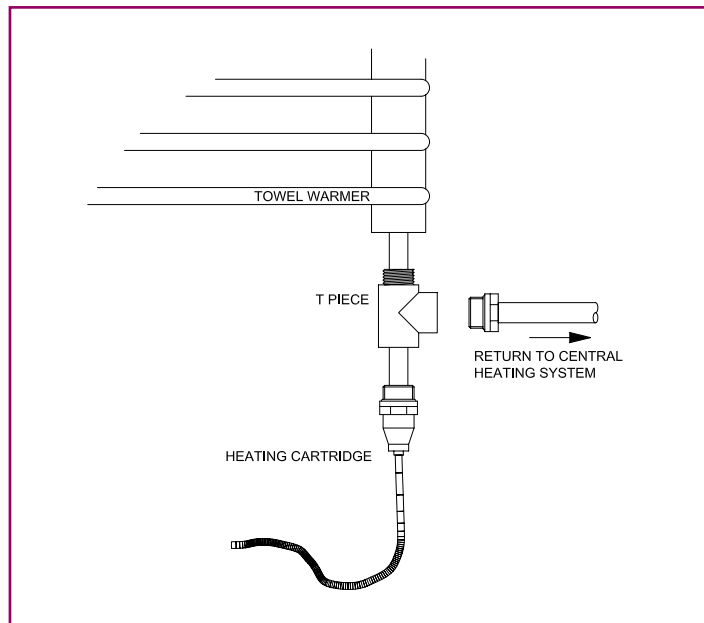

Fig.1



Dual Adaptor Kit

See Figure 1 or 2

A dual adaptor kit (electric element plus T-piece) is available to facilitate the running of QRT and QRC bathroom radiators from the electrical supply. This is used when the central heating system is not in use (during the summer months for example). Dual adaptor kits can be retrofit if required, see fig 1 and fig 2.

Both the Venus and Ares models also have the mixed function option.

Please note that type of heating element to be used with each radiator differs according to height and width. Please consult with a member of the Merriott Radiators radiator technical team for further information.

Fig.2

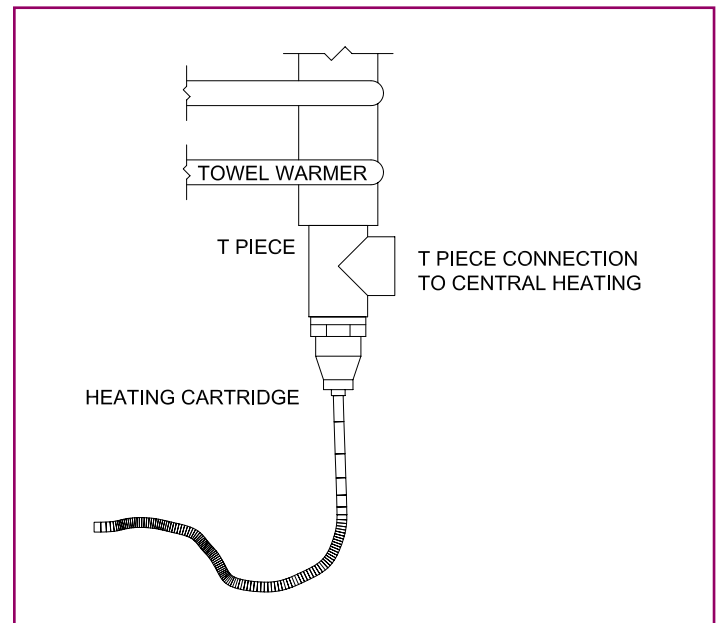

Applications - Bracket Details

Surface mounting brackets insitu and exploded

QRT Bracket

Use the bracket shown in Fig 5 and Fig 6 with the QRT range.



Fig.5



Fig.6

QRC and VENUS Brackets

Use the bracket shown in Fig 7 and Fig 8 with the QRC and VENUS ranges.



Fig.7



Fig.8

Correction Factors

Emissions at two separate delta TCs ($\Delta T^{\circ}\text{C}$ s) are provided in the heat emission charts in this catalogue.

Listed below are the correction factors needed to calculate the emission at other delta T's (ΔT s) between 20° and 60°C. This is done by correcting your heat emission with the appropriate correction factor selected from here.

Example

Say, required room temperature = 21°C, flow temperature = 86°C, return temperature = 72°C

How is the emission found?

Solution

Mean water temperature = $(T^{\circ}\text{ flow} + T^{\circ}\text{ return})/2 = (86 + 72)/2 = 79^{\circ}\text{C}$

DeltaT° = mean water temp - required room temp = $79 - 21 = 58^{\circ}\text{C}$

Thus, from the tables below, the emission for a QRT 800 x 600 is 0.962 times the emission given in the output tables e.g 483W @ Length 600mm = 465 watts @ $\Delta T50^{\circ}$

$\Delta T(^{\circ}\text{C})\text{P}$	Based on $\Delta T50$	Based on $\Delta T56$
20	0.280	0.271
21	0.296	0.287
22	0.312	0.303
23	0.329	0.319
24	0.345	0.336
25	0.362	0.353
26	0.379	0.370
27	0.396	0.387
28	0.413	0.404
29	0.430	0.421
30	0.448	0.438
31	0.465	0.456
32	0.482	0.473
33	0.500	0.491
34	0.517	0.509
35	0.535	0.527
36	0.553	0.545
37	0.571	0.563
38	0.589	0.581
39	0.607	0.599
40	0.625	0.617

$\Delta T(^{\circ}\text{C})\text{P}$	Based on $\Delta T50$	Based on $\Delta T56$
41	0.643	0.636
42	0.661	0.654
43	0.679	0.673
44	0.698	0.691
45	0.716	0.710
46	0.735	0.729
47	0.753	0.748
48	0.772	0.767
49	0.791	0.786
50	0.809	0.805
51	0.828	0.824
52	0.847	0.843
53	0.866	0.863
54	0.885	0.882
55	0.904	0.902
56	0.923	0.921
57	0.942	0.941
58	0.962	0.960
59	0.981	0.980
60	1.000	1.000

Resistance Diagram

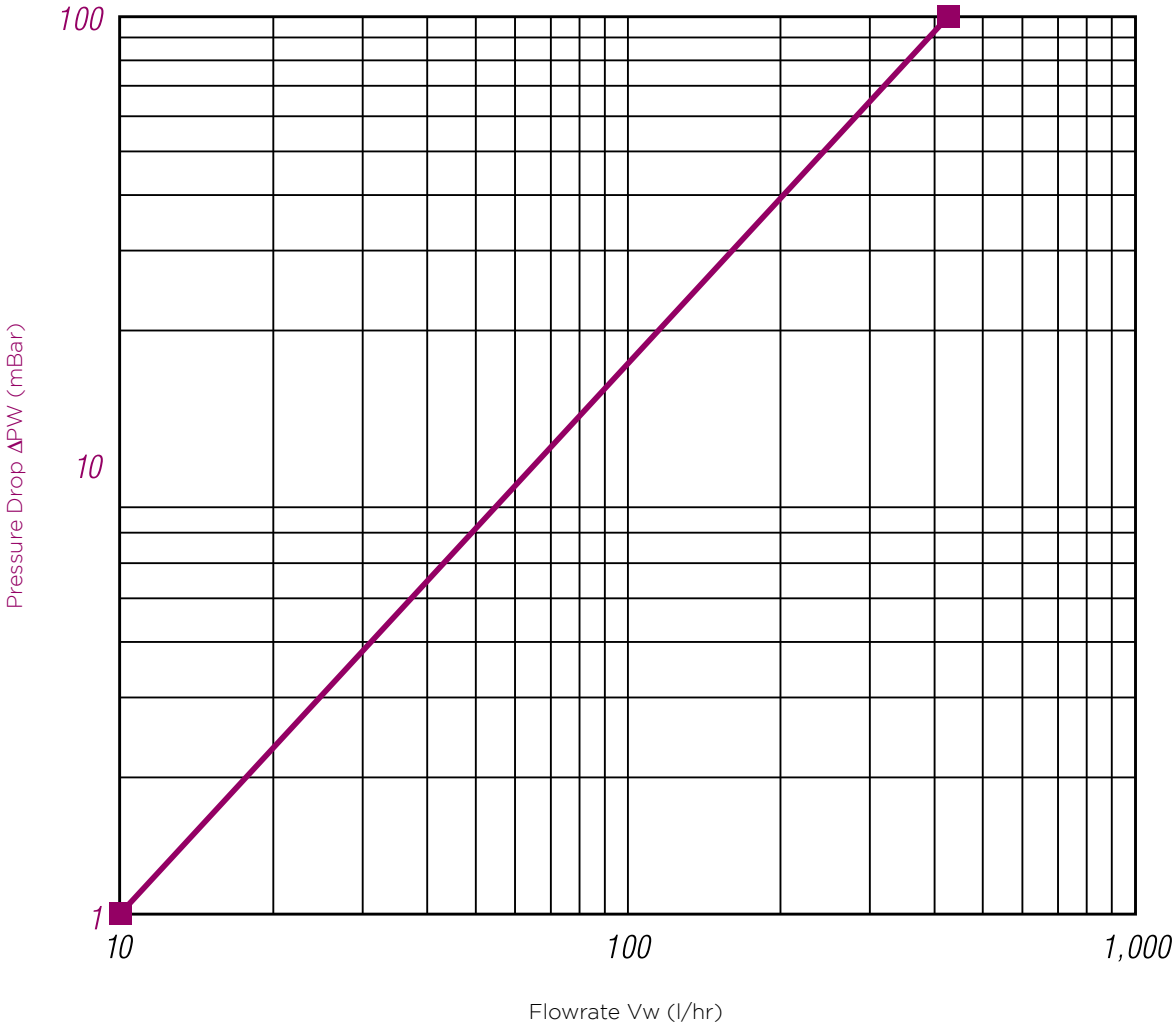

Resistance

The following is how to calculate the Resistance of a Bathroom Radiator

The following is how to calculate the resistance of a bathroom radiator type QRT 1800 mm high X 600 mm wide:

First, establish what the output of the bathroom radiator is.

This is found in the catalogue. (For this particular example please see page 4.)

Output from the Catalogue is 1292 Watts

In this example the system is operating at $\Delta T 56^{\circ}\text{C}$ (Flow@ 82°C , Return 71°C).

(If the output is for a $\Delta T^{\circ}\text{C}$ other than what is indicated in the emission tables ($\Delta T 50^{\circ}\text{C}$ or $\Delta T 56^{\circ}\text{C}$) please use the correction factor tables indicated to get the corrected output.)

C is the Specific Heat Constant (always $4187\text{J/Kg}^{\circ}\text{C}$)

Calculate the flow rate as follows:

$$Q = (m) \times (C) \times (\Delta T)$$

Output = (Flow Rate) (Constant) (Difference between flow and return temperature)

$$\text{Watts} = (l/s) (J/Kg^{\circ}\text{C}) (^{\circ}\text{C})$$

$$1292 = (m) (4187) (11)$$

Therefore

$$m = 1292 / ((4187) \times (11))$$

$$m = 0.028052196 \text{ Litres per Second (l/s) multiply by 3600 to convert to litres per hour}$$

$$m = 100.98 \text{ litres per hour (l/hr)}$$

Now, look up the Resistance Diagram:

Reading from the chart this gives a value of 18.2 mBar or 1.82 Kpa.

All bathroom radiators use the same resistance diagram.

Please note:

All models supplied with a dual adaptor kit will have a flow rate when operating on a central heating system, when these radiators are operating as a electric towel radiator they do not have a flowrate.

How to Order Towel Rails

Type QRT		
Height 800mm		
Heat Emission (watts)		
Width mm	$\Delta T50$	$\Delta T56$
500	403	463
600	483	555
750	604	694

Type QRT		
Height 1200mm		
Heat Emission (watts)		
Width mm	$\Delta T50$	$\Delta T56$
500	589	676
600	707	811
750	884	1015

Type QRT		
Height 1800mm		
Heat Emission (watts)		
Width mm	$\Delta T50$	$\Delta T56$
500	938	1077
600	1126	1292
750	1408	1615

Type QRC		
Height 800mm		
Heat Emission (watts)		
Width mm	$\Delta T50$	$\Delta T56$
500	367	420
600	441	504
750	551	630

Type QRC		
Height 1200mm		
Heat Emission (watts)		
Width mm	$\Delta T50$	$\Delta T56$
500	536	614
600	644	737
750	804	922

Type QRC		
Height 1800mm		
Heat Emission (watts)		
Width mm	$\Delta T50$	$\Delta T56$
500	811	931
600	973	1117
750	1217	1396

Merriott Radiators Ireland

Derrylin, Co. Fermanagh, Northern Ireland, BT92 9AU

For contact numbers please see below.

Email : sales@merriott-radiators.com

Web : www.merriott-radiators.com

Manufacturing Facility Newport

Merriott Radiators, Imperial Park, Newport, Gwent NP10 8ZY

Tel : +44 (0) 1633 657 000

Fax : +44 (0) 1633 657 084

Irish Enquires

Quotes:

Tel : +44 (0) 28 6774 2606

Fax: +353 (0) 49 9525231

Orders:

Tel : +44 (0) 28 6774 2535

Fax: +353 (0) 49 9525231

UK Enquires

Quotes:

Tel : +44 (0) 28 6774 2549

Fax: +44 (0) 28 6774 8107

Orders:

Tel : +44 (0) 28 6774 2503

Fax: +44 (0) 28 6774 8107

Merriott Radiators Ireland

Derrylin, Co. Fermanagh, Northern Ireland, BT92 9AU

For contact numbers please see below.

Email : sales@merriott-radiators.com

Web : www.merriott-radiators.com

Manufacturing Facility Newport

Merriott Radiators, Imperial Park, Newport, Gwent NP10 8ZY

Tel : +44 (0) 1633 657 000

Fax : +44 (0) 1633 657 084

Irish Enquires

Quotes:

Tel : +44 (0) 28 6774 2606

Fax: +353 (0) 49 9525231

Orders:

Tel : +44 (0) 28 6774 2535

Fax: +353 (0) 49 9525231

UK Enquires

Quotes:

Tel : +44 (0) 28 6774 2549

Fax: +44 (0) 28 6774 8107

Orders:

Tel : +44 (0) 28 6774 2503

Fax: +44 (0) 28 6774 8107