

# FlexCore 6

## Objective

McCue products are tested for compliance and product failure analysis to determine safe working conditions.

## Scope

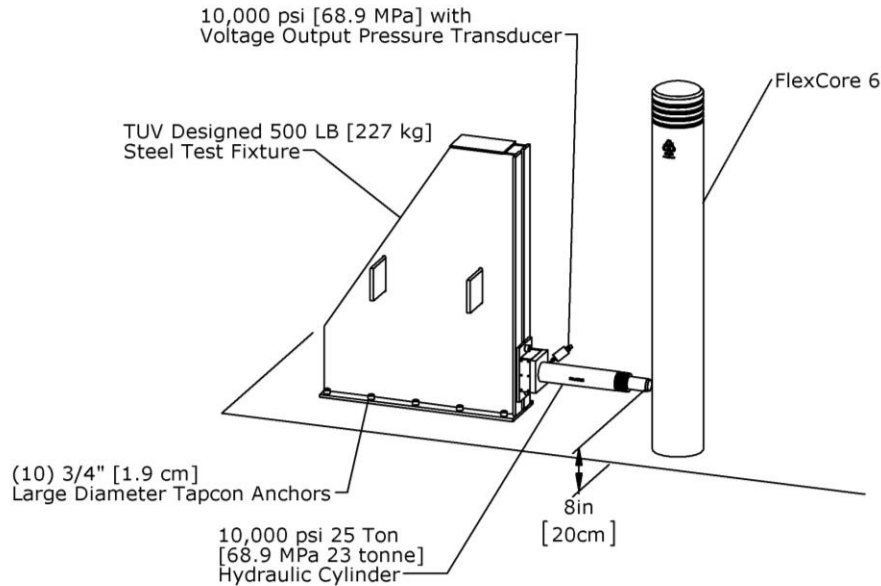

Products are tested for compliance to international standards and codes by taking dynamic measurements in real time of applied force and resulting deflection. Force and deflection measurements are used to determine the magnitude of energy transfer to the product by using principles of the work energy theorem. The criteria for product failure has been defined as a 4" [10 cm] deflection with the intent of balancing product robustness, floor space, and application for safe working conditions.

## Maximum Force & Deflection

$$F_{\max} = 12,995 \text{ lb [57.8 kN]}$$

$$\delta_{\max} = 4" [10.2 \text{ cm}]$$

$$v_{\perp} = 4.5 \text{ mph [7.2 km/h]}$$

$$v_{45} = 19.8 \text{ mph [32 km/h]}$$

The FlexCore 6 can withstand a perpendicular force of 12,995 lb [57.8 kN] limiting deflection to 4" [10 cm]. This is equivalent to an impact from a 6,500 lb [2948 kg] vehicle traveling at 4.5 mph [7.2 km/h]. In testing, the FlexCore 6 was subjected to higher loadings and further deflections.

The described test demonstrates the worst case scenario of a perpendicular impact. In application, typical impacts will be at an angle and result in lower collision energies. The FlexCore 6 can withstand an impact from a 6,500 lb [2948 kg] vehicle traveling at a 45° angle of incidence with a velocity of  $v_{45} = 19.8 \text{ mph [32 km/h]}$

*These tests were performed for McCue Corporation only and not subject to acceptance criteria. The test setup, testing, and measurement of data were all witnessed by TRIS and testing results were verified as accurate.*