

Deflector Post



Sometimes the best defense is rolling with it.

Distributing impact energy with rock and spin capabilities, the Deflector Post protects against glancing blows—perfect for high-traffic corners. Engineered to install fast and require no maintenance, it keeps your business rolling right along.

Rotating HDPE Shell Exclusive design rocks, rolls and lifts when hit

Flexible Core Absorbs direct impacts, preventing damage to your facility

Zero Maintenance Install it once, get peace of mind for years

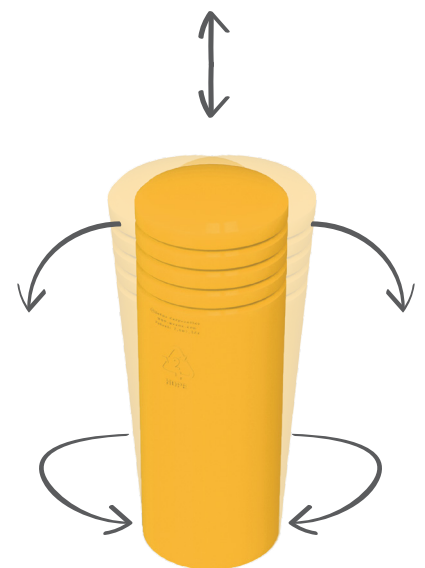

Deflector Post

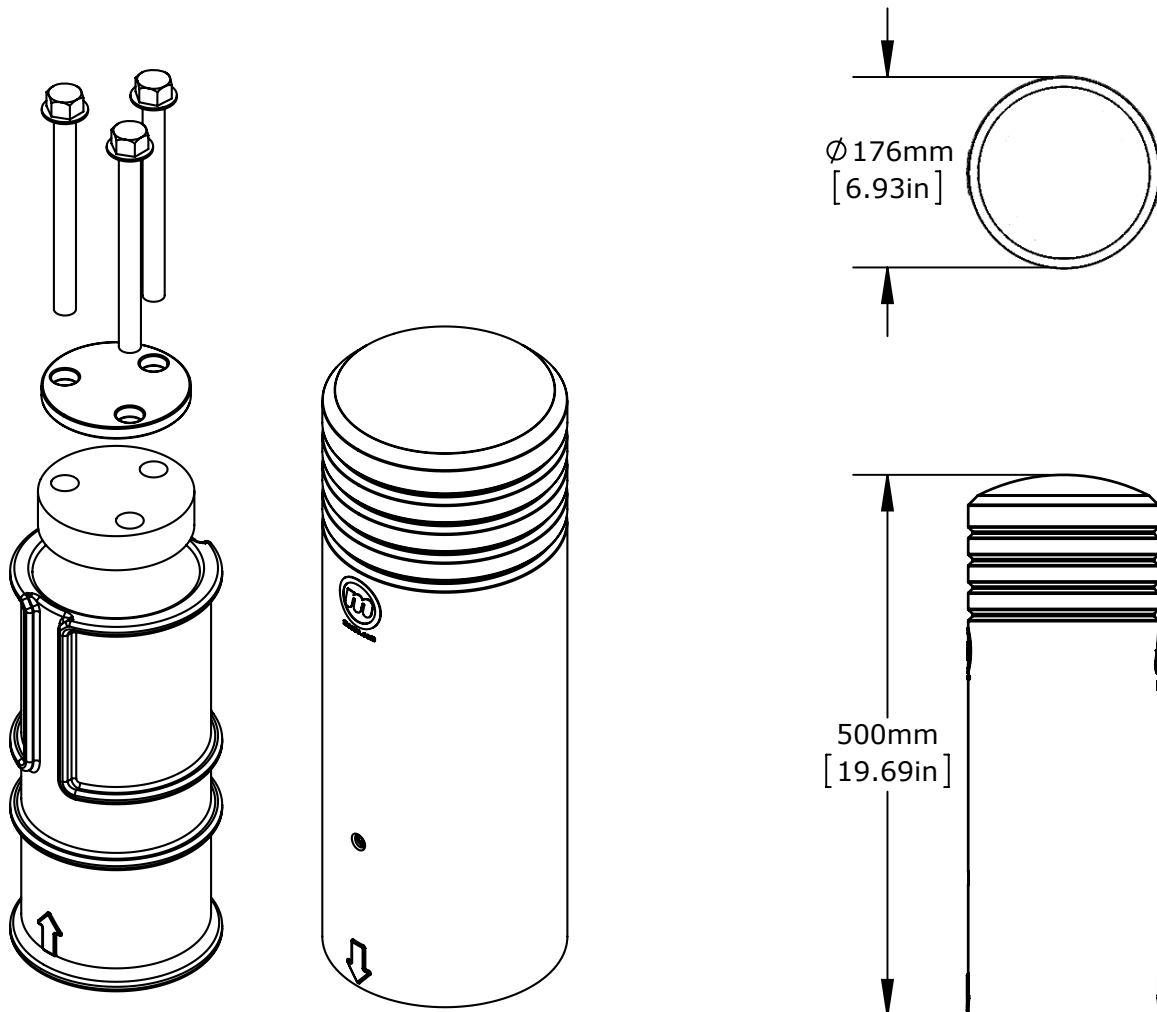

Deflector Post

17AJ601-307

Materials: HDPE shell, iron core,
rubber damper, anchor kit



Guides your equipment around high traffic corners to avoid damage.



McCue Corporation
Peabody, MA 01960, USA
+1 (800) 800 8503
customercare@mccue.com

McCue UK & Europe
Milton Keynes, United Kingdom
+44 (0)1908 365 511
uksales@mccue.com

McCue Asia
迈客(厦门)有限公司
Xiamen, Fujian, China
+86-592-2200790

mccue.com

