



Experience washrooms that go beyond.

The Washroom Studio River House 143-145 Farringdon Road London EC1R 3AB

Call 024 7662 1122

Email [inspired@maxwoodwashrooms.com](mailto:inspired@maxwoodwashrooms.com)

Visit [www.maxwoodwashrooms.com](http://www.maxwoodwashrooms.com)

# Maxwall

HPL / SGL

Practical and pleasing to the eye, Maxwall gives the finishing touch to any washroom, neatly concealing pipework and cisterns whilst uniting all the design elements. It has a well deserved reputation for simplicity, flexibility and exceptional ease of installation. A reliable and straightforward ducting system which also benefits from an outstanding range of premium finishes.

Wide range of colours available to suit any look & feel - other highly bespoke finishes available on request

---

Flexibility - made to measure and your design

---

Rapid installation due to modular kit-of-parts configuration; pre-finished shadows prevent any on-site laminating

---

Precision - All panels supplied pre-hung on factory-assembled aluminium frames

---

Easy to maintain and sanitise

---

Sanitaryware support rails factory-fitted

---

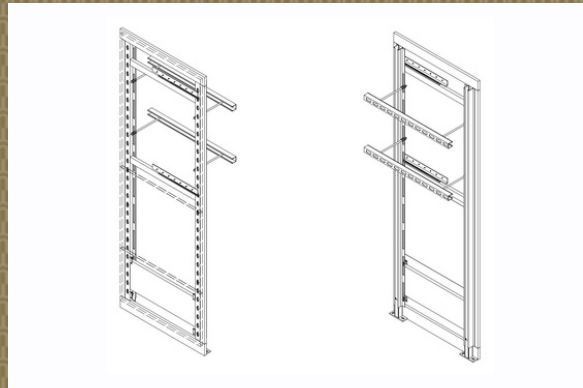

## Specification

### MAXWALL HPL

Reference: Maxwood MAXWALL HPL

#### FRAME ASSEMBLY

Core Material: 2mm aluminium vertical extrusions, anchored to the floor with galvanised mild steel brackets. Support rails for wash-hand basins, urinals and panel mounted WC's are manufactured from 25mm plywood and factory fitted. All facing panels are pre-hung for quick site installation.

Plinth & Shadows: Centre/end/top shadows and plinth manufactured from 18mm moisture resistant medium density fibreboard faced in high pressure laminate and balanced, eliminating on site laminating.

Plinth & Shadow Colours: As per client choice.

Fixing: Secured to rear wall using threaded rod fixed into wall-mounted Unistrut channel – all supplied as an entire ducting package.

#### PANEL

Core Material: 18mm moisture resistant particle board 650kg/m<sup>3</sup>.

Colour/Finish: High pressure laminate as per client choice, giving 20mm overall panel thickness. Balanced on reverse.

Edge Treatment: All edges lipped in impact-resistant ABS with polyurethane adhesive (see below)

Adhesive Type: All components are bonded with specialist polyurethane washroom adhesive, for ultimate water-resistance and strength of bonding. This adhesive is environmentally friendly with its zero rating on formaldehyde emissions.

Fixings: Heavy duty nylon lift-off or push-fit concealed clips.

#### PANEL OPTIONS

Side-hinged upper panels.

Lockable panels with chrome escutcheon.

Security fixings to removable panels.

Experience washrooms  
that go beyond.

The Washroom Studio River House 143-145 Farringdon Road London  
EC1R 3AB  
Call 024 7662 1122  
Email [inspired@maxwoodwashrooms.com](mailto:inspired@maxwoodwashrooms.com)  
Visit [www.maxwoodwashrooms.com](http://www.maxwoodwashrooms.com)





## Specification

### MAXWALL SGL

Reference: Maxwood MAXWALL SGL

#### FRAME ASSEMBLY

Core Material: 2mm aluminium vertical extrusions, anchored to the floor with galvanised mild steel brackets. Support rails for wash-hand basins, urinals and panel mounted WC's are manufactured from 25mm plywood and factory fitted. All facing panels are pre-hung for quick site installation.

Plinth & Shadows: Centre/end/top shadows and plinth manufactured from 18mm moisture resistant medium density fibreboard faced in high pressure laminate and balanced, eliminating on site laminating.

Plinth & Shadow Colours: As per client choice.

Fixing: Secured to rear wall using threaded rod fixed into wall-mounted Unistrut channel – all supplied as an entire ducting package.

#### PANEL

Core Material: 12.5mm solid grade laminate - fully waterproof.

Colour/Finish: Solid grade laminate chosen as per client choice, giving 12.5mm overall panel thickness.

Edge Treatment: All edges radiused and polished.

Fixings: Heavy duty nylon lift-off or push-fit concealed clips

#### PANEL OPTIONS

Side-hinged upper panels.

Lockable panels with chrome escutcheon.

Security fixings to removable panels.



Experience washrooms  
that go beyond.

The Washroom Studio River House 143-145 Farringdon Road London  
EC1R 3AB  
Call 024 7662 1122  
Email [inspired@maxwoodwashrooms.com](mailto:inspired@maxwoodwashrooms.com)  
Visit [www.maxwoodwashrooms.com](http://www.maxwoodwashrooms.com)





Experience washrooms that go beyond.

The Washroom Studio River House 143-145 Farringdon Road London EC1R 3AB

Call 024 7662 1122

Email [inspired@maxwoodwashrooms.com](mailto:inspired@maxwoodwashrooms.com)

Visit [www.maxwoodwashrooms.com](http://www.maxwoodwashrooms.com)



# Maxwall

GLASS

Practical and beautiful, Maxwall Glass provides the finishing touch to any washroom, serving to unite all the design elements whilst concealing services with a premium finish. It has a well deserved reputation for flexibility and exceptional ease of installation and the inclusion of glass finishes takes the aesthetics of this reliable ducting system, to another level.

Wide range of glass colours & finishes available

---

Highly resistant to tough cleaning detergents

---

All panels supplied pre-hung on frame

---

Pre-assembled aluminium frame construction

---

Pre-finished shadows - no on-site laminating

---

Precision - made to measure and your design

---

Exceptional ease of installation

---

Sanitaryware support rails factory-fitted

---



## Specifications

### MAXWALL GLASS

Reference: Maxwood MAXWALL GLASS

#### FRAME ASSEMBLY

Core Material: 2mm aluminium vertical extrusions, anchored to the floor with galvanised mild steel brackets. Support rails for wash-hand basins, urinals and panel mounted WC's are manufactured from 25mm plywood and factory fitted. All facing panels are pre-hung for quick site installation.

Plinth & Shadows: Centre/end/top shadows and plinth manufactured from 18mm moisture resistant medium density fibreboard faced in high pressure laminate and balanced, eliminating on site laminating.

Plinth & Shadow Colours: As per client choice.

Fixing: Secured to rear wall using threaded rod fixed into wall-mounted Unistrut channel – all supplied as an entire ducting package.

#### PANEL

Core Material: 6mm toughened back-painted glass bonded onto MFMDf substrate.

Colour/Finish: Back painted in colour of client choice.

Edge Treatment: All glass edges bevelled and polished and edges of substrate panel lipped in impact-resistant ABS with polyurethane adhesive (see below).

Adhesive Type: All components are bonded with specialist polyurethane washroom adhesive, for ultimate water-resistance and strength of bonding. This adhesive is environmentally friendly with its zero rating on formaldehyde emissions.

Fixings: Heavy duty nylon lift-off or push-fit concealed clips; middle or upper panel side hinged with friction-stay hinges.

Sanitaryware Apertures: All necessary cut-outs will be machined via templates supplied by contractor.

#### PANEL OPTIONS

Choice of alternative glass finishes including satin, reeded and interlayered glass (more available on request).

Lockable panels with chrome escutcheon.

Security fixings to removable panels

Glass panel trims.



Experience washrooms  
that go beyond.

The Washroom Studio River House 143-145 Farringdon Road London  
EC1R 3AB  
Call 024 7662 1122  
Email [inspired@maxwoodwashrooms.com](mailto:inspired@maxwoodwashrooms.com)  
Visit [www.maxwoodwashrooms.com](http://www.maxwoodwashrooms.com)





Experience washrooms that go beyond.

The Washroom Studio River House 143-145 Farringdon Road London EC1R 3AB

Call 024 7662 1122

Email [inspired@maxwoodwashrooms.com](mailto:inspired@maxwoodwashrooms.com)

Visit [www.maxwoodwashrooms.com](http://www.maxwoodwashrooms.com)



# Maxwall

Tile Backer Board

The latest addition to the Maxwall family, this version allows the premium aesthetic of tiling to be combined with the practicality of a traditional duct panel system. It has a well deserved reputation for simplicity, flexibility and exceptional ease of installation whilst also being compatible with any range of wall tiles.

Hinged panel option allows service access without unsightly inset access panels

---

Supplied with pre-hung tile-backer-board panels, ready for tiling by others, which allows tiling contractor to maintain a consistent finish across the whole tiling package

---

Pre-assembled aluminium frame construction

---

Pre-finished shadows - no on-site laminating

---

Precision - made to measure and your design

---

Sanitaryware support rails factory-fitted

---

Compatible with any range of wall tiles

---



## Specification

### MAXWALL TILE BACKER BOARD

Reference: Maxwood MAXWALL TILE BACKER BOARD

#### FRAME ASSEMBLY

Core Material: 2mm aluminium vertical extrusions, anchored to the floor with galvanised mild steel brackets. Support rails for wash-hand basins, urinals and panel mounted WC's are manufactured from 25mm plywood and factory fitted. All facing panels are pre-hung for quick site installation.

Shadows: Centre, end and top shadows manufactured from 18mm medium density fibreboard faced in high pressure laminate and balanced, eliminating on site laminating.

Shadow Colours: As per client choice.

Fixing: Secured to rear wall using threaded rod fixed into wall-mounted Unistrut channel – all supplied as an entire ducting package

#### PANEL

Core Material: 25mm plywood panel, balanced on reverse and faced with 12.5mm "Marmox" tile-backer board.

Colour/Finish: *Panel left untiled, for tiling by others.*

Edge Treatment: All edges lipped in 2mm PVC lipping. *Tile trim not included.*

Adhesive Type: All components are bonded with specialist polyurethane washroom adhesive, for ultimate water-resistance and strength of bonding. This adhesive is environmentally friendly with its zero rating on formaldehyde emissions.

Fixings: Heavy duty metal lift-off or push-fit concealed clips. Option for side-hung, friction-stay hinges, where required.

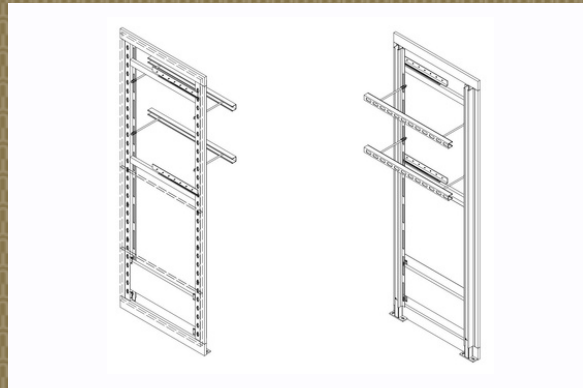

Experience washrooms  
that go beyond.

The Washroom Studio River House 143-145 Farringdon Road London  
EC1R 3AB  
Call 024 7662 1122  
Email [inspired@maxwoodwashrooms.com](mailto:inspired@maxwoodwashrooms.com)  
Visit [www.maxwoodwashrooms.com](http://www.maxwoodwashrooms.com)

