

Stabox[®] | reinforcement continuity systems



technologies for the construction industry



Stabox® | product description

When creating a conventional concrete frame construction consisting for example of walls and slabs, the traditional method of ensuring reinforcement continuity between the two elements requires complicated, time consuming and ultimately expensive site-adapted formwork. Rebar connection systems, sometimes known as continuity strips, provide a fast, elegant and cost effective solution which allows formwork to be quickly erected and the concrete cast. Once the formwork is stripped, the reverse of the continuity strip can be removed, exposing the captive rebar stirrups which are then re-bent to form the starter laps for the next element.

Because of these benefits, it is now difficult to imagine a modern concrete construction without these connection systems.

Its market-proven combination of micro-profiled sheet steel with a dovetail or trapezoidal box shape ensures a strong anchorage in the concrete, meaning that Stabox satisfies the highest design requirements for transverse and longitudinal force transmission in the joint. Further benefits include:

- Rebar components are CARES approved, complying with BS 4449:2005 Grade B500B/C, which means the rebar will not crack when re-bent and the integrity of the joint is maintained.
- Stabox is designed and manufactured to strict specifications, ensuring that the latest design standards for concrete construction are met.

- Loadbearing calculations are available for all models, including transverse and longitudinal force resistance which means that the Stabox system can be specified across the whole project, simplifying product procurement.
- Stabox is available in multiple configurations, with rebar diameters of 12 & 16 mm all with galvanised casings.
- Stabox units can be fitted to curved surfaces. Further information and datasheets are available upon request.

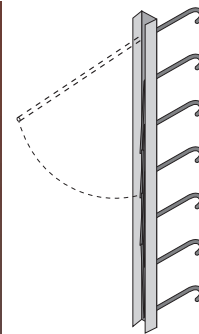

**Stabox®
Type A or Type H**
Standard shape case with single row of rebar

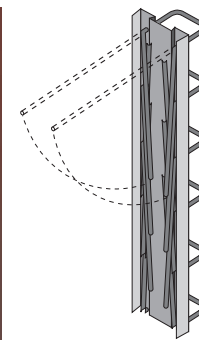

**Stabox® S
Type B**
Standard shape case for transverse interlocking

Stabox® S - product references

| Product code | Product width | Stirrup dia. | Stirrup width | Stirrup centres | End lap | No. rebars | Lap length |
|--------------|---------------|--------------|---------------|-----------------|---------|------------|------------|
| UKSTA16B1215 | 160 | 12 | 140 | 150 | 75 | 8 | 500 |
| UKSTA16B1220 | 160 | 12 | 140 | 200 | 100 | 6 | 500 |
| UKSTA19B1215 | 190 | 12 | 170 | 150 | 75 | 8 | 500 |
| UKSTA19B1220 | 190 | 12 | 170 | 200 | 100 | 6 | 500 |
| UKSTA19B1615 | 190 | 16 | 170 | 150 | 75 | 8 | 650 |
| UKSTA19B1620 | 190 | 16 | 170 | 200 | 100 | 6 | 650 |
| UKSTA22B1215 | 220 | 12 | 200 | 150 | 75 | 8 | 500 |
| UKSTA22B1220 | 220 | 12 | 200 | 200 | 100 | 6 | 500 |
| UKSTA22B1615 | 220 | 16 | 200 | 150 | 75 | 8 | 650 |
| UKSTA22B1620 | 220 | 16 | 200 | 200 | 100 | 6 | 650 |
| UKSTA25B1215 | 250 | 12 | 220 | 150 | 75 | 8 | 500 |
| UKSTA25B1220 | 250 | 12 | 220 | 200 | 100 | 6 | 500 |
| UKSTA25B1615 | 250 | 16 | 220 | 150 | 75 | 8 | 650 |
| UKSTA25B1620 | 250 | 16 | 220 | 200 | 100 | 6 | 650 |

Fixing instructions

Stabox rebar connection system is fixed in place by either

- nailing it to the formwork (timber formwork)
- tying it to the reinforcement (sliding formwork)
- riveting it to the formwork (metal formwork)

Re-bending

Please make sure that only suitable tools are used for re-bending (refer to table opposite):

- Lift rebar slightly and bend up to an angle of max. 20° from the case.
- Using the FRANK re-bending tool, gradually straighten the rebar until it is perpendicular to the case. After each incremental movement, adjust the re-bending tool so that it is seated as close to the apex of the bend as possible.
- Do not carry out re-bending at temperatures below 5 °C.
- Take care not to over straighten the rebar, as further bending to correct this may cause microscopic cracks in the bar and weaken the joint.



FRANK re-bending tools

| Article number | Ø mm | colour |
|----------------|------|--------|
| STARBW10 | 10 | green |
| STARBW12 | 12 | red |
| STARBW16 | 16 | blue |

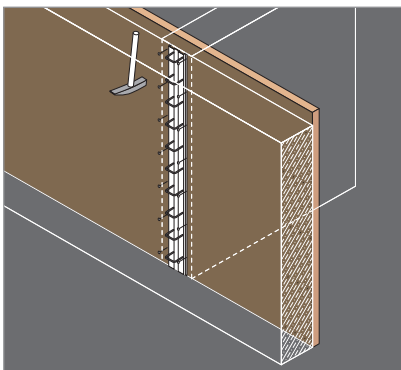
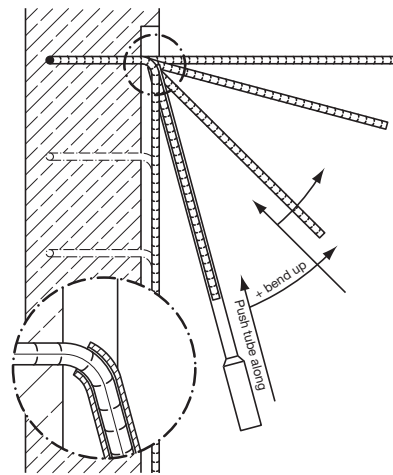

Installation of Stabox rebar connections in the 1st concrete pour.

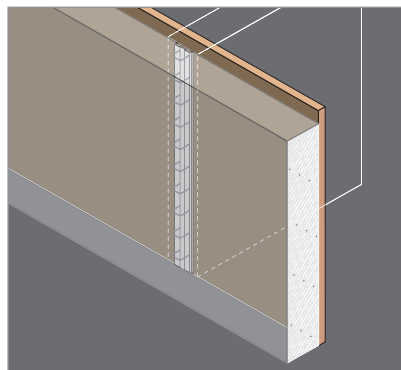

Fixing of reinforcement and 1st concrete pour.

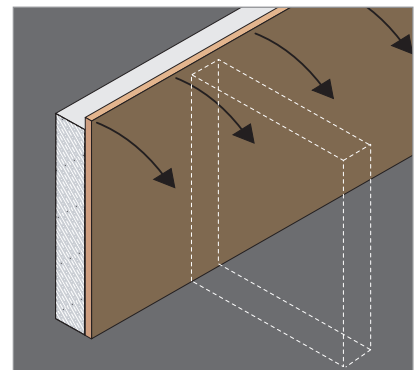

Formwork removal.

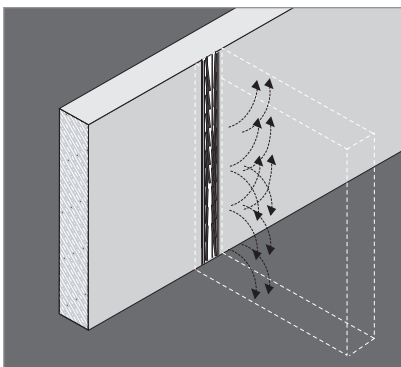

Remove cover carefully with a claw hammer and re-bend steel rebars according to the instructions above.

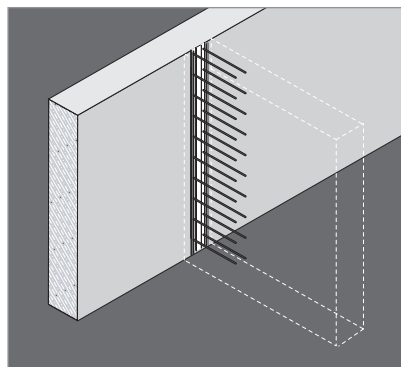

The reinforcement is installed, the formwork is erected and the 2nd concrete pour can take place.

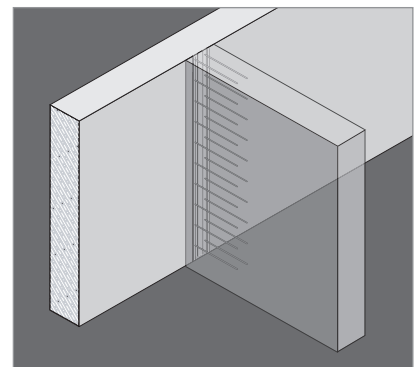

Completely finished wall connection with Stabox rebar connection system.

Max Frank GmbH & Co. KG | Technologies for the construction industry

Mitterweg 1
94339 Leiblfing · Germany
Phone +49 (0) 94 27 / 1 89-0 · Fax +49 (0) 94 27 / 15 88
info@maxfrank.com
www.maxfrank.com



Max Frank Limited | Technologies for the construction industry

Whittle Road
Meir
Stoke-on-Trent
ST3 7HF

Phone 01782 598 041
Fax 01782 315 056

info@maxfrank.co.uk
www.maxfrank.co.uk



www.maxfrank.co.uk