

FRANK | Technologies for the construction industry

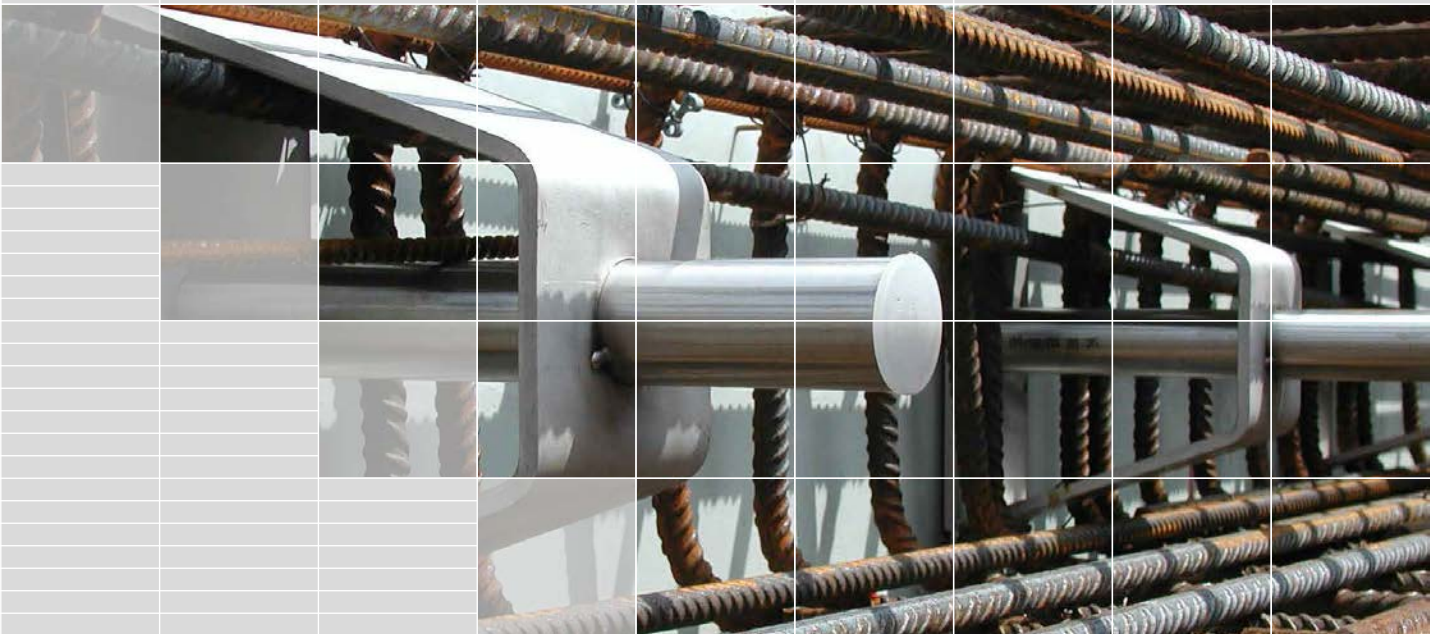

Egcodorn DND

Shear force dowel connection for the transmission of fatigue loads







Max Frank GmbH & Co. KG

Mitterweg 1

94339 Leibl fing

Phone +49 9427 189-0

Fax +49 94 27 15 88

info@maxfrank.de

www.maxfrank.com

Contents

Introduction	4
Areas of application	5
Dimensions and reinforcement.	6
Design	8
Design values.	9
Design example	14
Application examples.	16
Planning aids	18
More Egcodorn products.	19

Introduction

Current standards often require a design verification for fatigue. The Egcodorn DND gives the design engineer the opportunity to specify coupled expansion joints exposed to fatigue action.

Unlike with conventional console designs, positive as well as negative shear forces can be transmitted, which is beneficial for passages.

The design of the joint is simplified by using Egcodorn DND shear dowels plus the construction process is thus accelerated. Particularly in combination with Stremaform® shuttering elements, significant time and cost advantages can be achieved on site.

In case of pressurised water, the shuttering element can be fitted for the installation of inner and outer joint sealing tapes.

Common areas of application are slab tracks, crane runways, road bridges and noise barriers.

Benefits of the Egcodorn DND:

- Shear dowel with DIBT approval (German Institute for Civil Engineering)
- Bearing of non-static loads
- Enables longitudinal movements
- Maximum corrosion protection thanks to high-quality stainless steel design

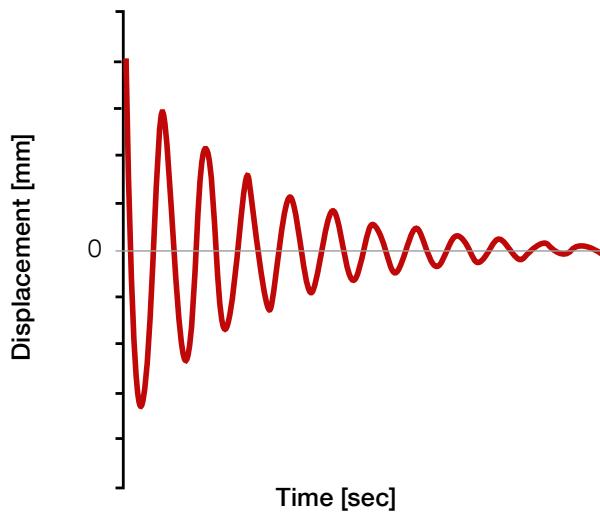

Areas of application

The special construction of the Egcodorn DND allows the transfer of not predominantly static loads. Oscillating actions often occur in joints subject to traffic and require particularly careful planning and execution.

Our application technology department would be happy to support you with this. Numerous completed projects prove our competence in the planning of joints exposed to fatigue loads.

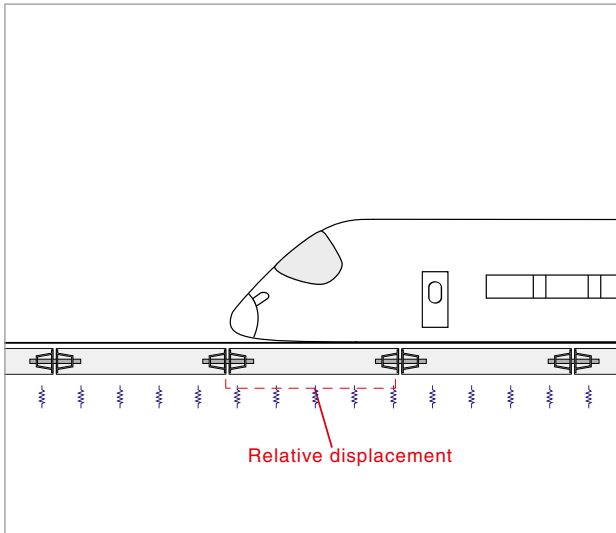

Slab track

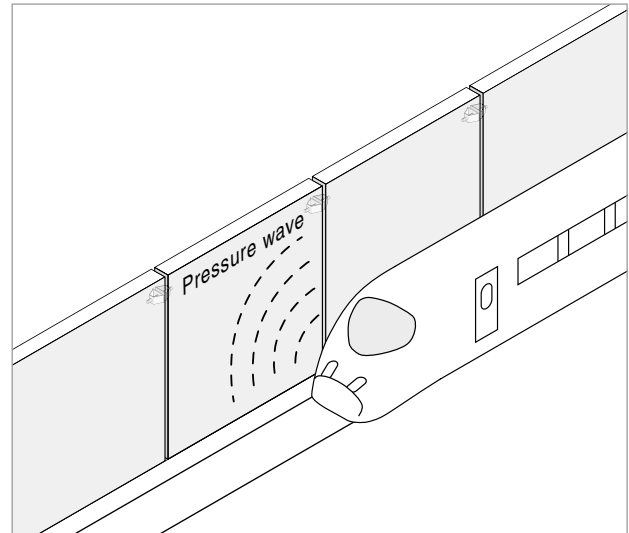

Noise barrier

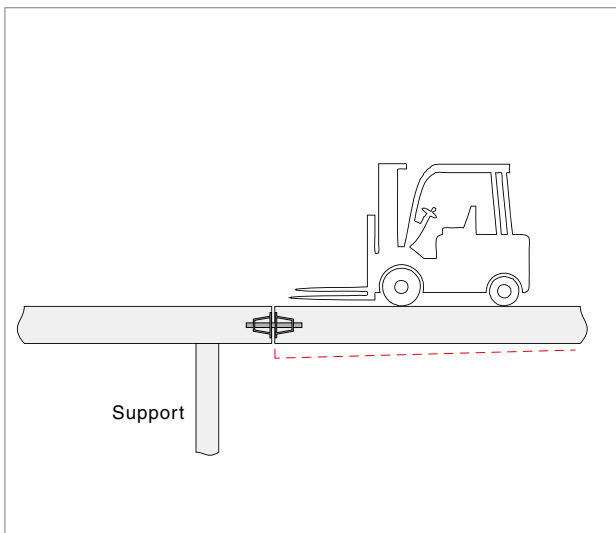

Pavement subject to forklift traffic

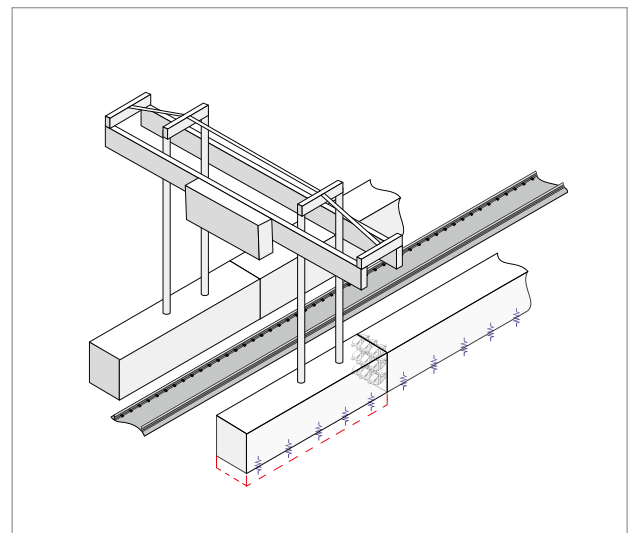

Crane runway

Dimensions and reinforcement

Dowel type	Axial distance of suspended reinforcement l_c [cm]	Minimum thickness of components being connected h_{min} [cm]	Minimum edge distance in load direction $a_{R1} = 0.5 \cdot h_{min}$ [cm]	Required axial distance $e = 3.0 \cdot d_m + l_c$ [cm]	Minimum axial distance $e_{min} = 1.5 \cdot h_{min}$ [cm]	Lateral minimum edge distance $a_r = 0.75 \cdot h_{min}$ [cm]
DND 40	7.7	16.0	8.0	43.7	24.0	12.0
DND 50	8.4	16.0	8.0	43.8	24.0	12.0
DND 70	9.4	18.0	9.0	50.8	27.0	13.5
DND 95	10.1	20.0	10.0	56.9	30.0	15.0
DND 100	11.0	22.0	11.0	63.8	33.0	16.5
DND 120	12.1	24.0	12.0	70.3	36.0	18.0
DND 150	12.5	26.0	13.0	75.5	39.0	19.5
DND 210	15.5	30.0	15.0	89.0	45.0	22.5
DND 300	18.5	32.0	16.0	98.0	48.0	24.0
DND 350	19.5	35.0	17.5	108.0	52.5	26.3

e minimum axial distance of shear dowel without mutual interference. The dimensioning tables on pages 9 to 13 may be applied without further verification.

a_r lateral minimum edge distance orthogonal to the load direction

d_m medium mean effective depth

e_{min} minimum distance for the verification of concrete edge failure. The verification of the shear load bearing capacity and/or punching shear shall be carried out according to DIN 1045 or DIN EN 1992 under static and non-static loads.

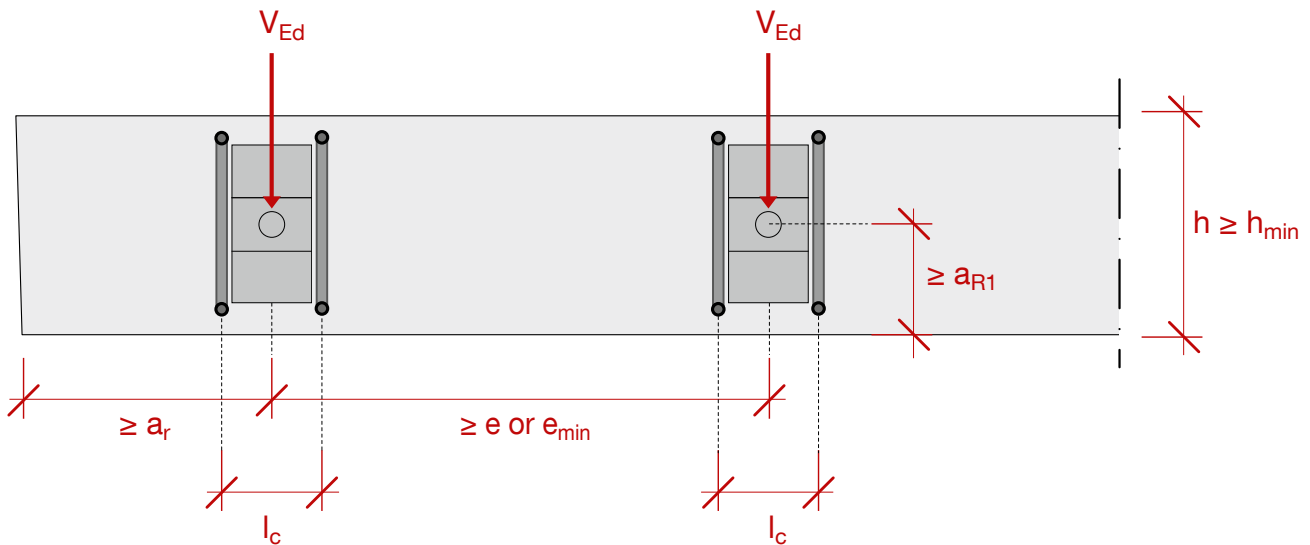

Slab thickness $h = h_{min}$

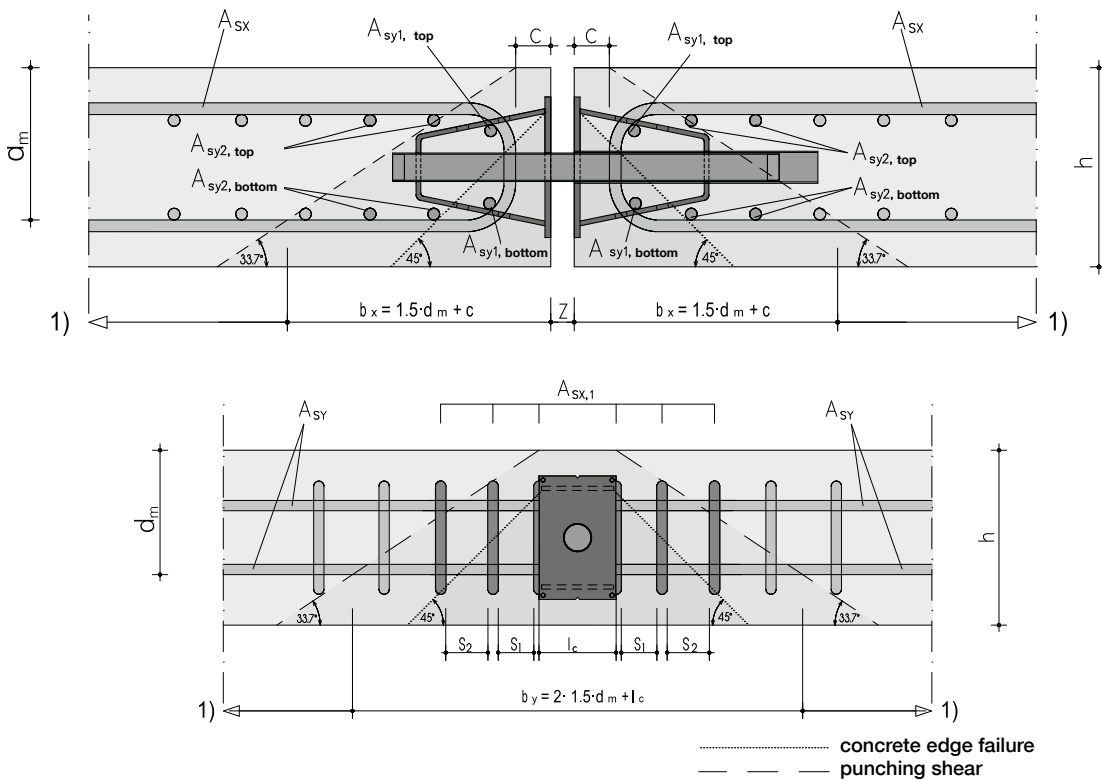

Slab thickness $h > h_{min}$

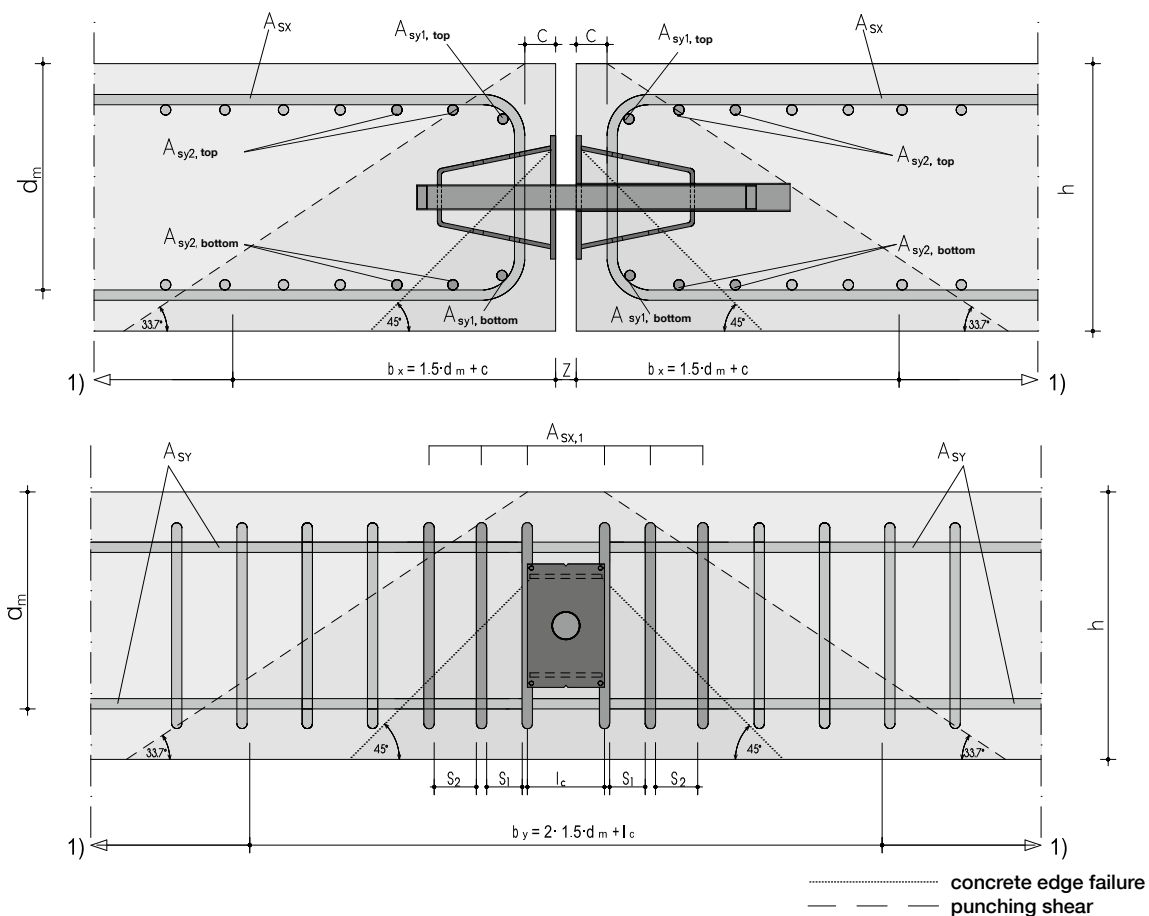

1) Anchorage length $l_{b,net}$ (DIN 1045-1) or l_{bd} (DIN EN 1992-1-1) of the stirrup A_{sx} is calculated from the point of interception of the concrete break out under 33.7° and the stirrup according to DIN 1045-1 and/or DIN EN 1992-1-1 with consideration of DIN EN 1992-1-1/NA, NCI to 8.4.4 (1)

Design

The verification must be carried out for the maximum applied shear force V_{Ed} , as well as for the maximum amplitude of the shear force ΔV_{Ed} . Both verifications must be carried out for the cast-in steel member as well as for the load transmission into the concrete. Comprehensive dimensioning tables are available for both cases.

It shall be noted that loads arising from earthquakes must be classified as extraordinary load cases and can also be verified with the Egcodorn WN/WQ suitable for static loads.

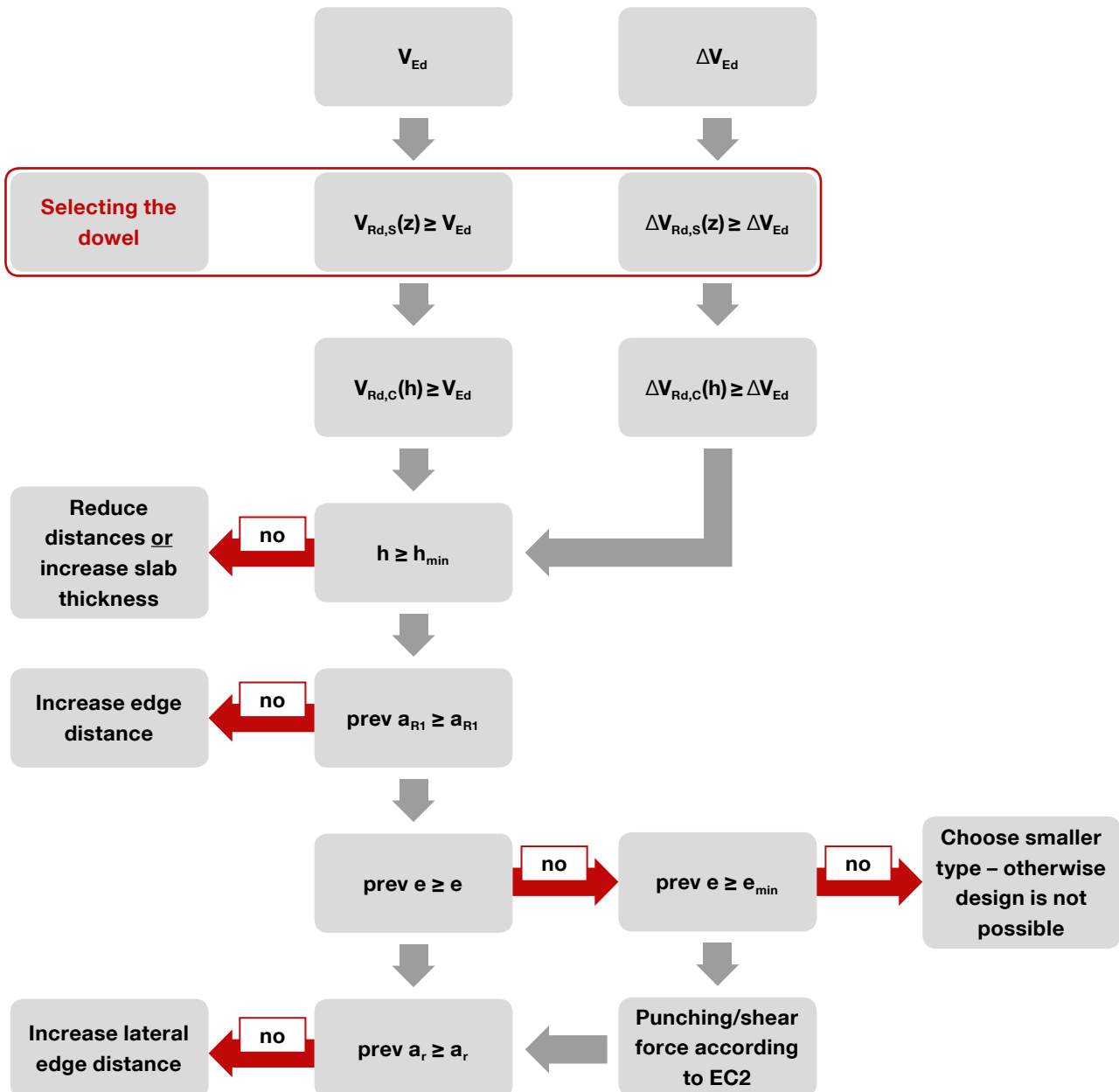

Egcodorn DND 40

Design values for the verification under fatigue depending on the joint width z

	z ≤ [mm]				
	20	30	40	50	60
Steel shear force bearing capacity $V_{Rd,S,o}$ [kN]	23.7	22.7	21.7	20.9	19.4
Steel shear force amplitude $\Delta V_{Rd,S}$ [kN]	9.3	8.9	8.5	7.1	5.9

Concrete bearing capacity

Component thickness h [mm]	$V_{Rd,c}$ ¹⁾ [kN]	$\Delta V_{Rd,c}$ ³⁾ [kN]	A_{Sx} A_{Sx1} [-]	A_{Sy} (upper and lower layer each)	
				A_{Sy1} [-]	A_{Sy2} [-]
160	23.7 ²⁾	9.3 ²⁾	4 Ø 10	1 Ø 10	2 Ø 10
180	23.7 ²⁾	9.3 ²⁾	4 Ø 8	1 Ø 8	2 Ø 8
200	23.7 ²⁾	9.3 ²⁾	4 Ø 8	1 Ø 8	2 Ø 8
220	23.7 ²⁾	9.3 ²⁾	4 Ø 8	1 Ø 8	2 Ø 8
240	23.7 ²⁾	9.3 ²⁾	4 Ø 8	1 Ø 8	2 Ø 8

Egcodorn DND 50

Design values for the verification under fatigue depending on the joint width z

	z ≤ [mm]				
	20	30	40	50	60
Steel shear force bearing capacity $V_{Rd,S,o}$ [kN]	28.0	26.9	25.9	25.0	24.1
Steel shear force amplitude $\Delta V_{Rd,S}$ [kN]	10.2	9.8	9.4	9.1	7.9

Concrete bearing capacity

Component thickness h [mm]	$V_{Rd,c}$ ¹⁾ [kN]	$\Delta V_{Rd,c}$ ³⁾ [kN]	A_{Sx} A_{Sx1} [-]	A_{Sy} (upper and lower layer each)	
				A_{Sy1} [-]	A_{Sy2} [-]
160	28.1 ²⁾	10.2 ²⁾	4 Ø 10	1 Ø 10	2 Ø 10
180	28.1 ²⁾	10.2 ²⁾	4 Ø 10	1 Ø 10	2 Ø 10
200	28.1 ²⁾	10.2 ²⁾	4 Ø 10	1 Ø 10	2 Ø 10
220	28.1 ²⁾	10.2 ²⁾	4 Ø 10	1 Ø 10	2 Ø 10
240	28.1 ²⁾	10.2 ²⁾	4 Ø 10	1 Ø 10	2 Ø 10

- 1) Design values of the concrete bearing capacity; valid for an axial distance $e \geq 3 \cdot d_m + l_c$; design to the upper threshold value of the connection bearing capacity
- 2) Design values of the steel bearing capacity; $V_{Rd,S}$ or $\Delta V_{Rd,S}$ for joint widths ≤ 20 mm are decisive
- 3) Design values of the concrete bearing capacity; valid for an axial distance $e \geq 3 \cdot d_m + l_c$; design to the threshold force amplitude of the connection (dynamic)

Egcodorn DND 70

Design values for the verification of fatigue resistance depending on the joint width z

	z ≤ [mm]				
	20	30	40	50	60
Steel shear force bearing capacity $V_{Rd,S,o}$ [kN]	39.6	38.2	36.9	35.7	34.6
Steel shear force amplitude $\Delta V_{Rd,S}$ [kN]	15.0	14.4	13.9	13.5	11.5

Concrete bearing capacity

Component thickness h [mm]	$V_{Rd,c}$ ¹⁾ [kN]	$\Delta V_{Rd,c}$ ³⁾ [kN]	A_{Sx} A_{Sx1} [-]	A_{Sy} (upper and lower layer each)	
				A_{Sy1} [-]	A_{Sy2} [-]
180	39.6 ²⁾	15.0 ²⁾	4 Ø 12	1 Ø 12	2 Ø 12
200	39.6 ²⁾	15.0 ²⁾	4 Ø 12	1 Ø 12	2 Ø 12
220	39.6 ²⁾	15.0 ²⁾	4 Ø 12	1 Ø 12	2 Ø 12
240	39.6 ²⁾	15.0 ²⁾	4 Ø 10	1 Ø 10	2 Ø 10
260	39.6 ²⁾	15.0 ²⁾	4 Ø 10	1 Ø 10	2 Ø 10

Egcodorn DND 95

Design values for the verification of fatigue resistance depending on the joint width z

	z ≤ [mm]				
	20	30	40	50	60
Steel shear force bearing capacity $V_{Rd,S,o}$ [kN]	53.2	51.5	49.9	48.5	47.1
Steel shear force amplitude $\Delta V_{Rd,S}$ [kN]	19.3	18.7	18.1	17.6	16.1

Concrete bearing capacity

Component thickness h [mm]	$V_{Rd,c}$ ¹⁾ [kN]	$\Delta V_{Rd,c}$ ³⁾ [kN]	A_{Sx} A_{Sx1} [-]	A_{Sy} (upper and lower layer each)	
				A_{Sy1} [-]	A_{Sy2} [-]
200	53.2 ²⁾	19.3 ²⁾	4 Ø 14	1 Ø 14	2 Ø 14
220	53.2 ²⁾	19.3 ²⁾	4 Ø 14	1 Ø 14	2 Ø 14
240	53.2 ²⁾	19.3 ²⁾	4 Ø 12	1 Ø 12	2 Ø 12
260	53.2 ²⁾	19.3 ²⁾	4 Ø 12	1 Ø 12	2 Ø 12
280	53.2 ²⁾	19.3 ²⁾	4 Ø 12	1 Ø 12	2 Ø 12

- 1) Design values of the concrete bearing capacity; valid for an axial distance $e \geq 3 \cdot d_m + l_c$; design to the upper threshold value of the connection bearing capacity
- 2) Design values of the steel bearing capacity; $V_{Rd,S}$ or $\Delta V_{Rd,S}$ for joint widths ≤ 20 mm are decisive
- 3) Design values of the concrete bearing capacity; valid for an axial distance $e \geq 3 \cdot d_m + l_c$; design to the threshold force amplitude of the connection (dynamic)

Egcodorn DND 100

Design values for the verification of fatigue resistance depending on the joint width z

	z ≤ [mm]				
	20	30	40	50	60
Steel shear force bearing capacity $V_{Rd,S,o}$ [kN]	57.1	55.4	53.8	52.3	50.9
Steel shear force amplitude $\Delta V_{Rd,S}$ [kN]	20.7	20.1	19.5	19.0	18.5

Concrete bearing capacity

Component thickness h [mm]	$V_{Rd,c}$ ¹⁾ [kN]	$\Delta V_{Rd,c}$ ³⁾ [kN]	A_{Sx} A_{Sx1} [-]	A_{Sy} (upper and lower layer each)	
				A_{Sy1} [-]	A_{Sy2} [-]
220	57.1 ²⁾	20.8 ²⁾	6 Ø 12	1 Ø 12	2 Ø 12
240	57.1 ²⁾	20.8 ²⁾	4 Ø 12	1 Ø 12	2 Ø 12
260	57.1 ²⁾	20.8 ²⁾	4 Ø 12	1 Ø 12	2 Ø 12
280	57.1 ²⁾	20.8 ²⁾	4 Ø 12	1 Ø 12	2 Ø 12
300	57.1 ²⁾	20.8 ²⁾	4 Ø 12	1 Ø 12	2 Ø 12

Egcodorn DND 120

Design values for the verification of fatigue resistance depending on the joint width z

	z ≤ [mm]				
	20	30	40	50	60
Steel shear force bearing capacity $V_{Rd,S,o}$ [kN]	66.0	64.1	62.4	60.7	59.2
Steel shear force amplitude $\Delta V_{Rd,S}$ [kN]	24.7	24.0	23.4	22.8	22.2

Concrete bearing capacity

Component thickness h [mm]	$V_{Rd,c}$ ¹⁾ [kN]	$\Delta V_{Rd,c}$ ³⁾ [kN]	A_{Sx} A_{Sx1} [-]	A_{Sy} (upper and lower layer each)	
				A_{Sy1} [-]	A_{Sy2} [-]
240	66.0 ²⁾	24.8 ²⁾	4 Ø 14	1 Ø 14	2 Ø 14
260	66.0 ²⁾	24.8 ²⁾	4 Ø 12	1 Ø 12	2 Ø 12
280	66.0 ²⁾	24.8 ²⁾	4 Ø 12	1 Ø 12	2 Ø 12
300	66.0 ²⁾	24.8 ²⁾	4 Ø 12	1 Ø 12	2 Ø 12
320	66.0 ²⁾	24.8 ²⁾	4 Ø 12	1 Ø 12	2 Ø 12

1) Design values of the concrete bearing capacity; valid for an axial distance $e \geq 3 \cdot d_m + l_c$; design to the upper threshold value of the connection bearing capacity

2) Design values of the steel bearing capacity; $V_{Rd,S}$ or $\Delta V_{Rd,S}$ for joint widths ≤ 20 mm are decisive

3) Design values of the concrete bearing capacity; valid for an axial distance $e \geq 3 \cdot d_m + l_c$; design to the threshold force amplitude of the connection (dynamic)

Egcodorn DND 150

Design values for the verification of fatigue resistance depending on the joint width z

	z ≤ [mm]				
	20	30	40	50	60
Steel shear force bearing capacity $V_{Rd,S,o}$ [kN]	85.0	82.8	80.8	78.8	76.9
Steel shear force amplitude $\Delta V_{Rd,S}$ [kN]	33.0	32.2	31.4	30.6	29.9

Concrete bearing capacity

Component thickness h [mm]	$V_{Rd,c}$ ¹⁾ [kN]	$\Delta V_{Rd,c}$ ³⁾ [kN]	A_{Sx} A_{Sx1} [-]	A_{Sy} (upper and lower layer each)	
				A_{Sy1} [-]	A_{Sy2} [-]
260	85.1 ²⁾	33.1 ²⁾	6 Ø 14	1 Ø 14	2 Ø 14
280	85.1 ²⁾	33.1 ²⁾	4 Ø 14	1 Ø 14	2 Ø 14
300	85.1 ²⁾	33.1 ²⁾	4 Ø 14	1 Ø 14	2 Ø 14
320	85.1 ²⁾	33.1 ²⁾	4 Ø 14	1 Ø 14	2 Ø 14
340	85.1 ²⁾	33.1 ²⁾	4 Ø 14	1 Ø 14	2 Ø 14

Egcodorn DND 210

Design values for the verification of fatigue resistance depending on the joint width z

	z ≤ [mm]				
	20	30	40	50	60
Steel shear force bearing capacity $V_{Rd,S,o}$ [kN]	116.1	113.5	110.9	108.5	106.2
Steel shear force amplitude $\Delta V_{Rd,S}$ [kN]	42.1	41.2	40.2	39.4	38.5

Concrete bearing capacity

Component thickness h [mm]	$V_{Rd,c}$ ¹⁾ [kN]	$\Delta V_{Rd,c}$ ³⁾ [kN]	A_{Sx} A_{Sx1} [-]	A_{Sy} (upper and lower layer each)	
				A_{Sy1} [-]	A_{Sy2} [-]
300	116.1 ²⁾	42.8 ²⁾	6 Ø 14	1 Ø 14	2 Ø 14
350	116.1 ²⁾	42.8 ²⁾	6 Ø 14	1 Ø 14	2 Ø 14
400	116.1 ²⁾	42.8 ²⁾	6 Ø 14	1 Ø 14	2 Ø 14
450	116.1 ²⁾	42.8 ²⁾	6 Ø 14	1 Ø 14	2 Ø 14
500	116.1 ²⁾	42.8 ²⁾	6 Ø 14	1 Ø 14	2 Ø 14

- 1) Design values of the concrete bearing capacity; valid for an axial distance $e \geq 3 \cdot d_m + l_c$; design to the upper threshold value of the connection bearing capacity
- 2) Design values of the steel bearing capacity; $V_{Rd,S}$ or $\Delta V_{Rd,S}$ for joint widths ≤ 20 mm are decisive
- 3) Design values of the concrete bearing capacity; valid for an axial distance $e \geq 3 \cdot d_m + l_c$; design to the threshold force amplitude of the connection (dynamic)

Egcodorn DND 300

Design values for the verification of fatigue resistance depending on the joint width z

	z ≤ [mm]				
	20	30	40	50	60
Steel shear force bearing capacity $V_{Rd,S,o}$ [kN]	162.7	159.7	156.8	154.1	151.4
Steel shear force amplitude $\Delta V_{Rd,S}$ [kN]	65.9	64.7	63.5	62.4	61.3

Concrete bearing capacity

Component thickness h [mm]	$V_{Rd,c}$ ¹⁾ [kN]	$\Delta V_{Rd,c}$ ³⁾ [kN]	A_{Sx} A_{Sx1} [-]	A_{Sy} (upper and lower layer each)	
				A_{Sy1} [-]	A_{Sy2} [-]
320	162.8 ²⁾	66.0 ²⁾	6 Ø 20	1 Ø 20	2 Ø 20
350	162.8 ²⁾	66.0 ²⁾	6 Ø 20	1 Ø 20	2 Ø 20
400	162.8 ²⁾	66.0 ²⁾	6 Ø 16	1 Ø 16	2 Ø 16
450	162.8 ²⁾	66.0 ²⁾	6 Ø 16	1 Ø 16	2 Ø 16
500	162.8 ²⁾	66.0 ²⁾	6 Ø 16	1 Ø 16	2 Ø 16

Egcodorn DND 350

Design values for the verification of fatigue resistance depending on the joint width z

	z ≤ [mm]				
	20	30	40	50	60
Steel shear force bearing capacity $V_{Rd,S,o}$ [kN]	192.1	188.5	185.1	181.8	178.6
Steel shear force amplitude $\Delta V_{Rd,S}$ [kN]	70.6	69.3	68.0	66.8	65.6

Concrete bearing capacity

Component thickness h [mm]	$V_{Rd,c}$ ¹⁾ [kN]	$\Delta V_{Rd,c}$ ³⁾ [kN]	A_{Sx} A_{Sx1} [-]	A_{Sy} (upper and lower layer each)	
				A_{Sy1} [-]	A_{Sy2} [-]
350	192.1 ²⁾	70.6 ²⁾	6 Ø 20	1 Ø 20	2 Ø 20
400	192.1 ²⁾	70.6 ²⁾	6 Ø 20	1 Ø 20	2 Ø 20
450	192.1 ²⁾	70.6 ²⁾	6 Ø 16	1 Ø 16	2 Ø 16
500	192.1 ²⁾	70.6 ²⁾	6 Ø 16	1 Ø 16	2 Ø 16
550	192.1 ²⁾	70.6 ²⁾	6 Ø 16	1 Ø 16	2 Ø 16

- 1) Design values of the concrete bearing capacity; valid for an axial distance $e \geq 3 \cdot d_m + l_c$; design to the upper threshold value of the connection bearing capacity
- 2) Design values of the steel bearing capacity; $V_{Rd,S}$ or $\Delta V_{Rd,S}$ for joint widths ≤ 20 mm are decisive
- 3) Design values of the concrete bearing capacity; valid for an axial distance $e \geq 3 \cdot d_m + l_c$; design to the threshold force amplitude of the connection (dynamic)

Design example

Given: Concrete: \geq C20/25
 Reinforcement: B500B
 Slab thickness: $h = 300$ mm
 Concrete cover: $c_{nom} = 30$ mm
 Joint width: $z \leq 40$ mm

Loads: Maximum value of the non-static shear force applied: $V_{Ed} = 80.0$ kN
 Maximum value of the shear force amplitude applied: $\Delta V_{Ed} = 31.0$ kN

Selected: DND 150; axial distance $e \geq 75.5$ cm (no mutual interference of the dowels)
 + 4 stirrups $\varnothing 14$ as edge reinforcement A_{Sx1} + 3 $\varnothing 14$ as longitudinal reinforcement A_{Sy}

1 Analysis of the steel bearing capacity

Maximum value of the shear force	Shear force amplitude
$V_{Rd,S} = 80.8$ kN	$\Delta V_{Rd,S} = 31.4$ kN
Verification: $\eta_s = \frac{80.0}{80.8} = 0.99 \leq 1.00$	Verification: $\eta_s = \frac{31.0}{31.4} = 0.99 \leq 1.00$

Design values for the verification of fatigue resistance depending on the joint width z

Egcodorn DND 150	z ≤ [mm]				
	20	30	40	50	60
Steel shear force bearing capacity $V_{Rd,S,o}$ [kN]	85.0	82.8	80.8	78.8	76.9
Steel shear force amplitude $\Delta V_{Rd,S}$ [kN]	33.0	32.2	31.4	30.6	29.9

Design values for the verification of fatigue resistance depending on the joint width z

Egcodorn DND 150	z ≤ [mm]				
	20	30	40	50	60
Steel shear force bearing capacity $V_{Rd,S,o}$ [kN]	85.0	82.8	80.8	78.8	76.9
Steel shear force amplitude $\Delta V_{Rd,S}$ [kN]	33.0	32.2	31.4	30.6	29.9

2 Analysis of the concrete bearing capacity

Maximum value of the shear force	Shear force amplitude
$V_{Rd,c} = 85.1 \text{ kN}$	$\Delta V_{Rd,S} = 33.1 \text{ kN}$
Verification: $\eta_s = \frac{80.0}{85.1} = 0.94 \leq 1.00$	Verification: $\eta_s = \frac{31.0}{33.1} = 0.94 \leq 1.00$

Concrete bearing capacity – Egcodorn DND 150

Component thickness h	$V_{Rd,c}$ ¹⁾	$\Delta V_{Rd,c}$ ³⁾	A_{Sx}	A_{Sy} (upper and lower layer each)	
				A_{Sy1}	A_{Sy2}
[mm]	[kN]	[kN]	[-]	[-]	[-]
260	85.1 ²⁾	33.1 ²⁾	6 Ø 14	1 Ø 14	2 Ø 14
280	85.1 ²⁾	33.1 ²⁾	4 Ø 14	1 Ø 14	2 Ø 14
300	85.1 ²⁾	33.1 ²⁾	4 Ø 14	1 Ø 14	2 Ø 14
320	85.1 ²⁾	33.1 ²⁾	4 Ø 14	1 Ø 14	2 Ø 14
340	85.1 ²⁾	33.1 ²⁾	4 Ø 14	1 Ø 14	2 Ø 14

- 1) Design values of the concrete bearing capacity; valid for an axial distance $e \geq 3 \cdot d_m + l_c$; design to the upper threshold value of the connection bearing capacity
- 2) Design values of the steel bearing capacity; $V_{Rd,S}$ or $\Delta V_{Rd,S}$ for joint widths $\leq 20 \text{ mm}$ are decisive
- 3) Design values of the concrete bearing capacity; valid for an axial distance $e \geq 3 \cdot d_m + l_c$; design to the threshold force amplitude of the connection (dynamic)

3 Constructive measures

The on-site reinforcement must be anchored outside of the punching cone and/or spliced with the reinforcement of the adjacent component.

The load transmission in the adjacent component needs to be verified.



Combination with Stremaform® formwork elements

Egcdorn dowels may be integrated into already manufactured Stremaform® formwork elements to ensure quick and efficient progress of works at the construction site.

The ready assembled units are positioned by crane which reduces the physical labor and supports the workers' health. Formwork elements can be fitted with joint supports to ensure joint sealing. Upon customer's request these joint sealants can already be installed in our factory. Where required, outside joint sealants including assembly supports are supplied to avoid joint contamination.

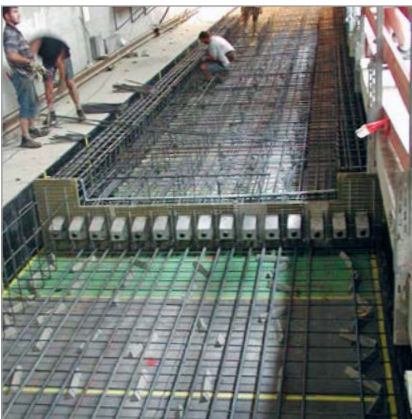

Mass-spring system

A large area of application for Egcodorn DND are float-mounted slab tracks (mass-spring systems), for example in the construction of underground tunnels.

Slab tracks can be separated from the surrounding components by an elastic bearing for decoupling of impact sound. In order to keep the relative displacements of the single track slabs at a low level and thus ensure enhanced driving comfort, we recommend a coupling of the joints using Egcodorn DND.



Noise barrier for ICE high speed lines

Noise barriers along high speed lines are considerably exposed to fatigue loads resulting from pressure waves triggered by passing trains.

Due to their length, noise barriers are longitudinally divided by joints. Shear force dowels of the Egcodorn DND type are used in order to reduce the relative displacements on the top of the wall.



Crane runway foundations

Due to the great length construction joints must be planned for crane runway foundations. In order to reduce the restraint forces resulting from the interaction of soil and structure these joints should be designed as expansion joints.



Egcodorn planning aids

Texts for invitation to tender and CAD details for our Egcodorn dowel systems are available as free downloads. These can be found at www.maxfrank.com



Technical consultation

Do you have any technical or product-related queries regarding Egcodorn?

Please contact our Technical Consultation Department

phone **+49 9427 189-189** or via e-mail: technik@maxfrank.de



More Egcodorn products

Egcodorn WN

The Egcodorn WN is used where movements only in the axial direction are to be considered. Very high static loads can be transmitted into thin components.

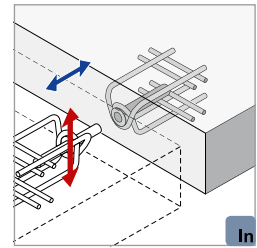

Egcodorn WQ

As movements in the direction of the dowel axis and perpendicular to the dowel axis occur, the Egcodorn WQ has to be used. A typical application is when the expansion joint changes its direction.

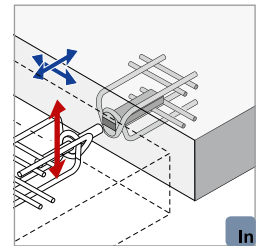

Egcodubel with sleeve

Egcodubels with sleeves are used for light-weight loads or for constructive connections. Depending on the durability requirements, Egcodubels can be supplied in stainless or galvanised steel. Sleeves for dowels that allow movement in the axial direction of the dowel are made of stainless steel or plastic, whereas sleeves for dowels with lateral movements are solely made of stainless steel.

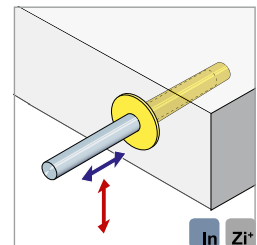
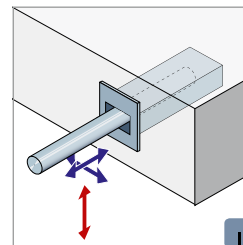
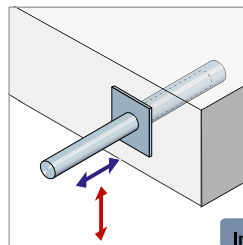

Egcodubel without sleeve

Egcodubel can also be supplied without sleeves for the connection of joints or false joints. We optionally supply dowel supports in line with your specifications.

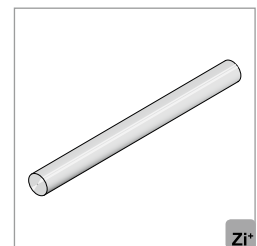
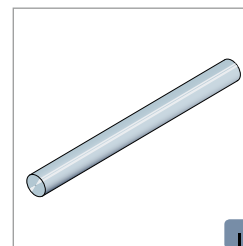

Egcotritt

The impact sound insulated shear force dowel Egcotritt allows acoustic decoupling of components. It is used for the support of stair landings, pergolas and elevated balconies and transmits the shear forces of the connection joint securely. At the same time, the acoustically decoupled support insulates excellently against distracting noises from adjacent rooms.

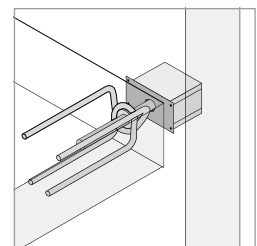

Further information can be found in our brochures "Egcodorn – shear force dowels for expansion joints" and "Egcotritt – decoupling of stair landings, pergolas and flights of stairs".



Max Frank GmbH & Co. KG

Mitterweg 1
94339 Leiblfing
Germany

Phone +49 9427 189-0

Fax +49 9427 1588

info@maxfrank.de

www.maxfrank.com