

FRANK | Technologies for the construction industry

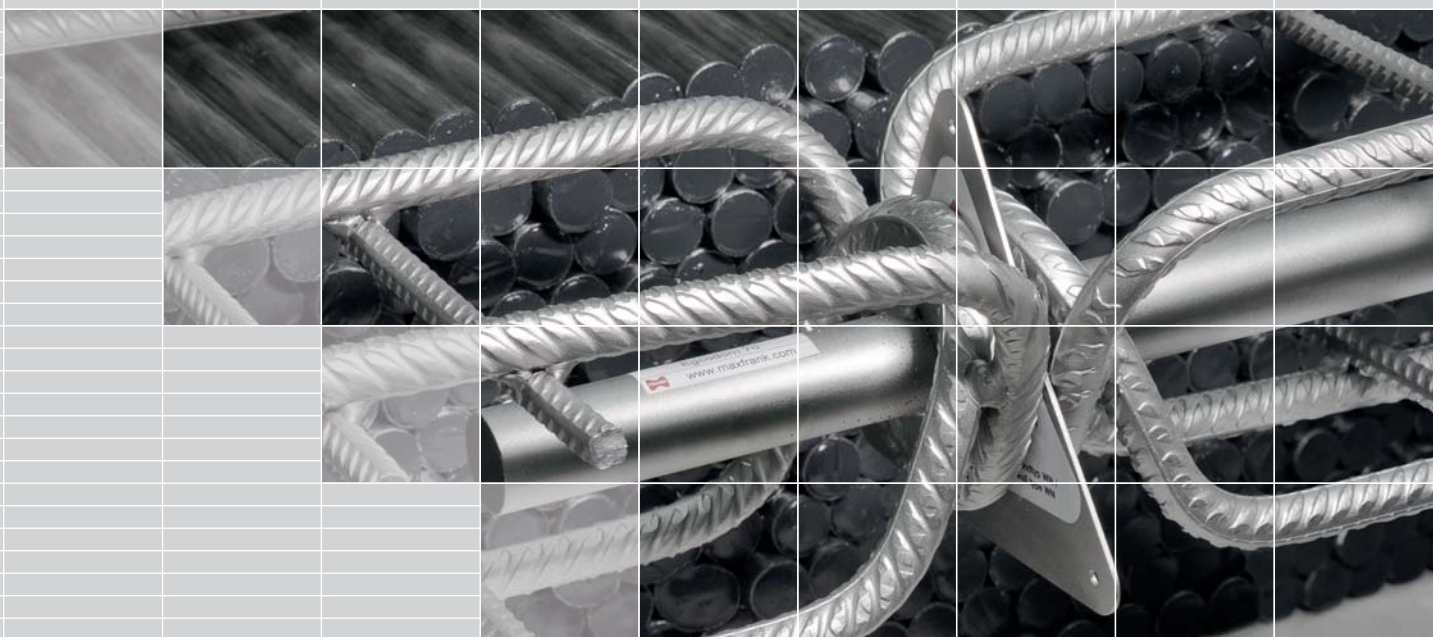

Egcodorn

Shear force dowel for expansion joints





SKY
TOWER



Max Frank GmbH & Co. KG

Mitterweg 1
 94339 Leiblfing
 Germany
 Phone +49 9427 189-0
 Fax +49 9427 1588
 info@maxfrank.com
 www.maxfrank.com

Contents

Egcodorn and Egcodubel

Typical applications 4

Egcodorn

System 6

Product description 8

Calculation 10

Application and installation details 16

Egcodubel

Product description 18

Egcodorn DND for dynamic loads

Product description 20

Egcodorn and Egcodubel

Installation aids 22

Key

- Force 
- Movement 
- Stainless steel 
- Galvanised 
- Plastic 

Egcodorn WN

The Egcodorn WN is used where movements only in the axial are to be considered.

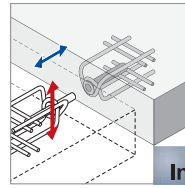

Egcodorn WQ

As movements in the direction of the dowel axis and perpendicular to the dowel axis occur, the Egcodorn WQ has to be used. A typical application is shown on the left-hand side on the attached picture, i.e. when the expansion joint direction changes.

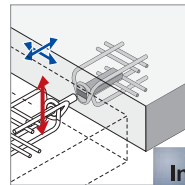

Egcodubel with sleeve

Egcodubels with sleeves are used for lightweight loads or for connection of structures. Depending on the durability requirements, Egcodubels can be supplied in stainless or galvanised steel. Sleeves for dowels that allow movement in the axial direction of the dowel are made of stainless steel or plastic, whereas sleeves for dowels with lateral movements are solely made of stainless steel.

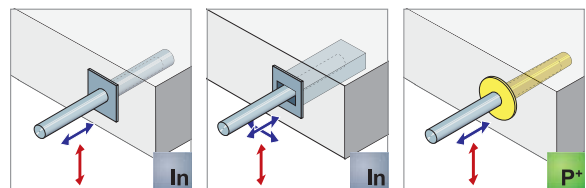

Egcodubel without sleeve

Egcodubel can also be supplied without sleeves for connecting working joints or contraction joints. We optionally supply dowel supports in line with your specifications.



Egcodorn DND for dynamic loads

Egcodorn DND is currently the only shear force dowel system approved for expansion joints subject to dynamic loads. This dowel system is primarily used in mass-springsystems or in multi-storey car parks.

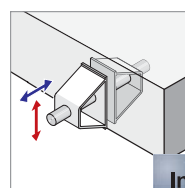

The Egcodorn shear force dowel transfers maximum loads whilst having a minimal component thickness and is mainly used for static loads. Our Egcodorn range offers numerous standard types. Also using our modular component system it allows you to combine various components according to your specific requirements. The use of high-quality materials and the unique corrosion protection system guarantee the highest safety and reliability.

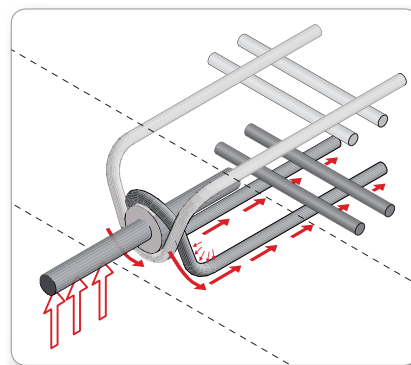
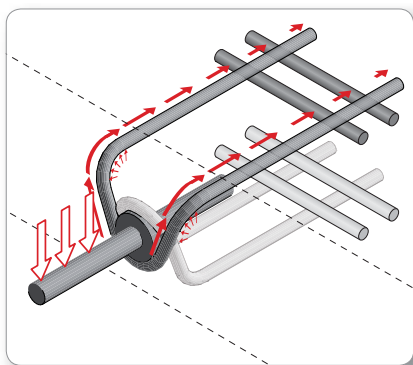

Egcodorn combines the excellent mechanical properties of the high-grade, load-bearing dowel core with excellent corrosion protection of the sleeve made of stainless steel grade 1.4571. The surface of the dowel is hardened to minimize friction and ensure smooth movement.

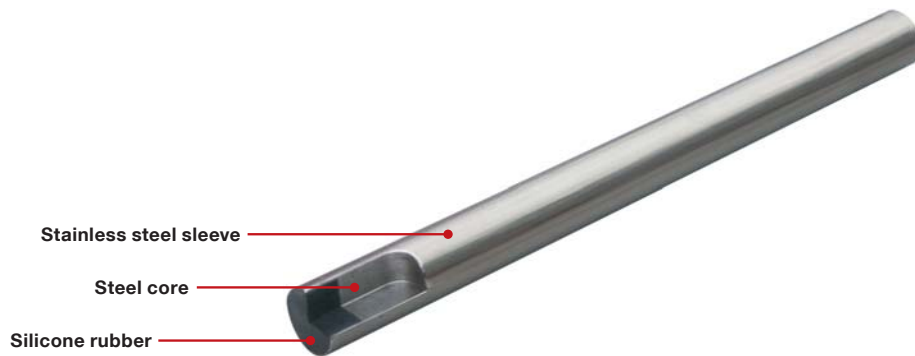

Egcodorn standard types

Standard Egcodorn types can accommodate most static loads. Whilst joint widths remain unchanged, shear force bearing capacity increases with the dowel diameter.

Egcodorn modular system

The new Egcodorn modular component system allows for dimensioning the Egcodorn according to the actual shear force and therefore to considerably increase the economic efficiency.

Vary dowel diameter, anchor body and joint width for an optimal material utilization.

Example: Large dowel diameter, small anchor body, large joint width

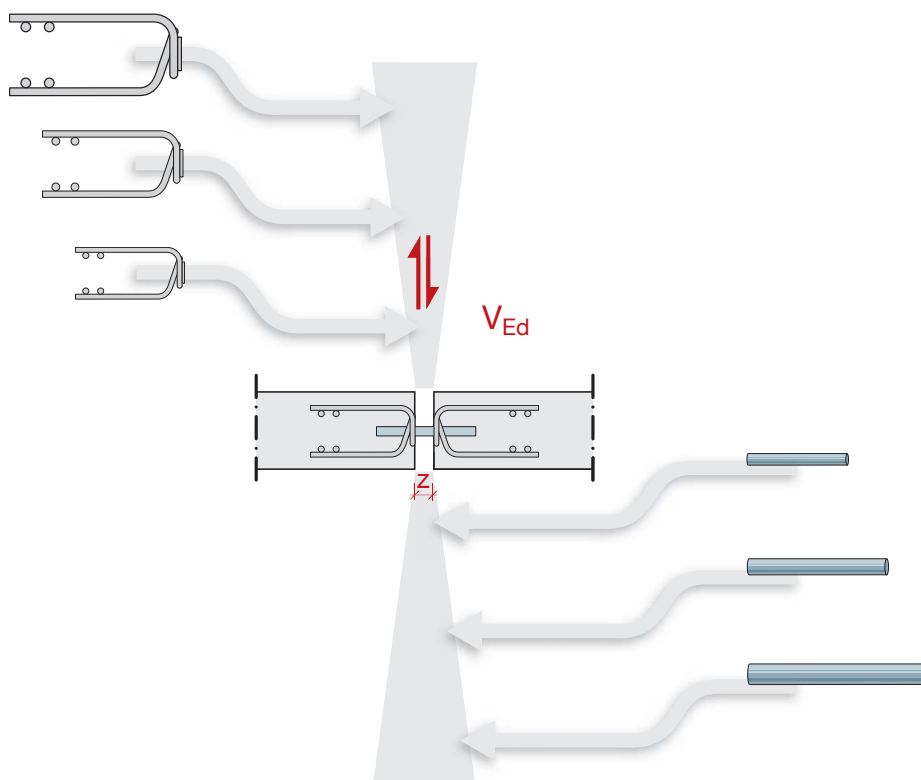

Egcodorn design

The loop-type design of the anchor body guarantees a homogeneous force transmission.

Deflection and rear anchorage of forces ensures optimal load transfer into the concrete whilst having a minimal component thickness.

The open design of the anchor body allows for easy integration of the Egcodorn into the existing reinforcement.

Advantages:

- Transfers maximum loads whilst having a minimum component thickness
- Individual combination of dowel and anchor body
- Easy installation due to open design



Egcodorn WN

Egcodorn type WN solely allows movements longitudinal to the dowel axle.

Dowels must be carefully placed in movement direction and must be parallel to each other.

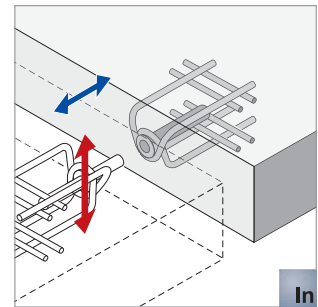

Egcodorn WQ

If longitudinal and lateral movement is required, Egcodorn WQ must be used.

For angled structural element corners or large joint lengths the Egcodorn WQ must be used.

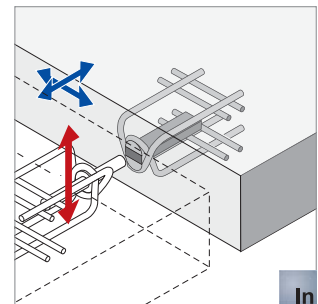

Standard types

Example: Egcodorn **WQ40**
Egcodorn Type

Type	Dowel diameter D [mm]	Anchor body d _s [mm]	Anchor body height h _D [mm]	Minimum wall thickness ¹⁾ [mm]
40	22	10	80	180
50	24	12	100	210
70	27	14	120	240
95	30	16	140	270
100	32	16	140	270
120	34	20	170	340
150	37	20	170	340
210	42	25	200	410
300	44	25	240	410
350	52	25	240	410

1) c_{nom} = 20 mm, increase wall thickness if necessary

Modular system

Example: Egcodorn **WN 22** – **12**
Egcodorn Type Dowel diameter – Anchor body diameter

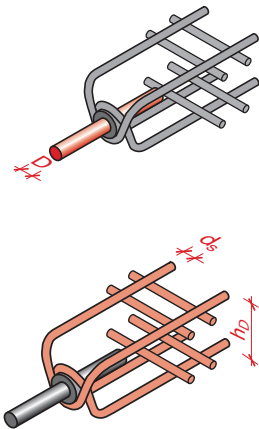

Typ	Dowel diameter D [mm]	Anchor body diameter d _s [mm]	Anchor body height h _D [mm]
WN	22	10	≥ 60
WQ	24	12	≥ 72
	27	14	≥ 84
	30	16	≥ 96
	32	20	≥ 120
	34	25	≥ 150
	37		
	42		
	44		
	52		

Dowel diameters and anchor bodies may be altered for the optimum design of the Egcodorn system.

Calculation

A Assessment of h_{\min}

The maximum permissible dowel and anchor body combination can be selected using the various required slab dimensions. In particular the minimum slab thickness h_{\min} must be complied with.

B V_{Rd} and joint width z

Dowel distances can now be determined based on the ratio between the joint width z and design loads V_{Ed} . The load-bearing capacity of the corresponding combination of dowel and anchor body can be calculated.

C Control of Dowel Centres

The selected dowel centres need to be checked to ensure the punching zones do not overlap (see picture C upper part). If they overlap (see picture C lower part) the slab edge should be checked for shear locally around the dowels.

D Punching test

For the punch proof the design aids can be used. If the distances between the dowels are too small, the verification of the shear design is necessary. A detailed design example is given on page 14 and 15.

Fire protection

If fire protection is required, fire protection collars can be supplied, so that the Egcodorn system fulfils the requirements of fire protection class R120.

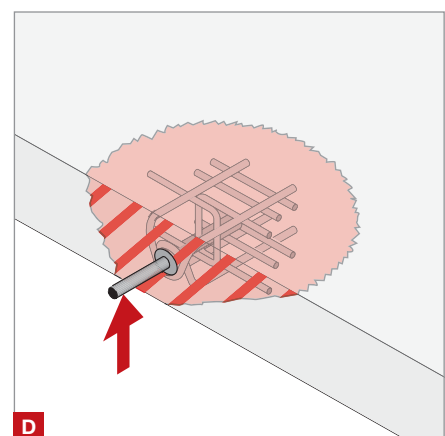
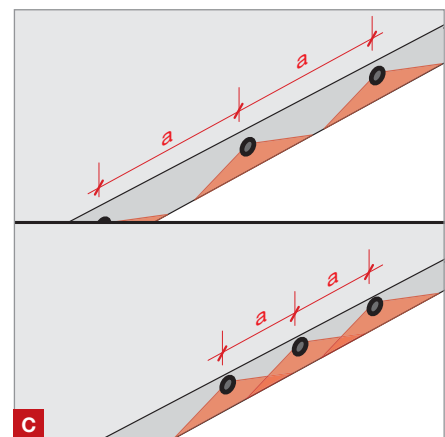
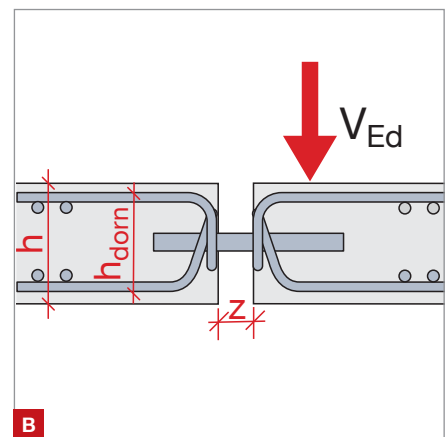
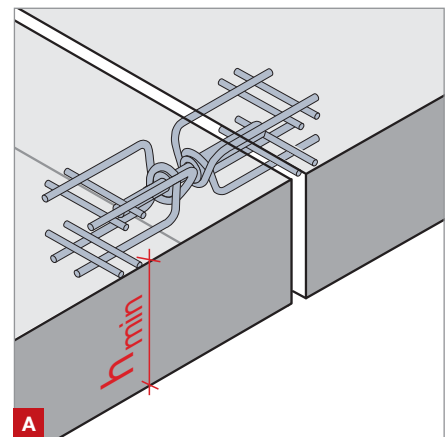

Standard types

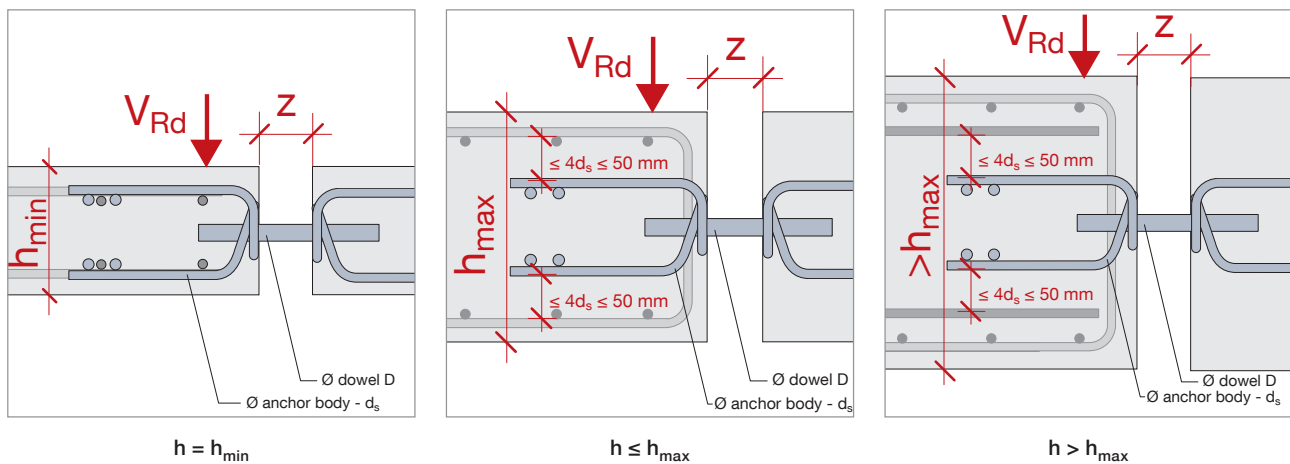
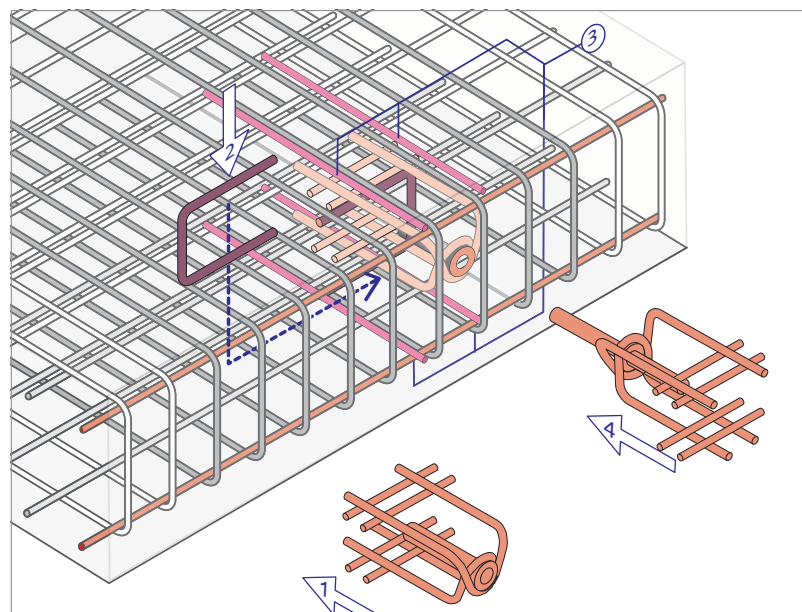

Chart 1 – Design shear forces and dimensions

Type 1)	Maximum load V_{Rd} (kN) for joint width z [mm] $\geq C20/25$												Slab thickness	
	V_{Rd} longitudinal or lateral						V_{Rd} longitudinal & lateral 2)						h_{min} 3)	h_{max} 4)
	10 mm	20 mm	30 mm	40 mm	50 mm	60 mm	10 mm	20 mm	30 mm	40 mm	50 mm	60 mm	[mm]	
WN40 / WQ40	62.0	58.9	54.5	40.9	32.7	27.3	62.0	58.9	49.1	36.8	29.5	24.5	140	240
WN50 / WQ50	89.4	85.3	72.2	54.5	43.6	36.3	89.4	83.7	65.0	49.0	39.2	32.7	160	280
WN70 / WQ70	122.3	117.4	102.9	79.9	63.9	53.3	122.3	113.9	92.6	71.9	57.5	47.9	180	308
WN95 / WQ95	154.7	149.1	138.7	112.2	89.8	74.8	154.7	148.6	124.8	100.9	80.8	67.4	200	332
WN100 / WQ100	155.8	150.6	145.7	136.9	110.5	92.0	155.8	150.6	145.7	123.2	99.4	82.8	210	332
WN120 / WQ120	241.5	224.4	194.1	163.9	134.1	111.7	229.2	201.9	174.7	147.4	120.6	100.5	230	370
WN150 / WQ150	243.8	236.8	230.3	208.4	175.3	146.2	243.8	236.8	217.3	187.5	157.7	131.5	250	370
WN210 / WQ210	380.3	369.5	331.6	293.8	255.9	218.2	366.6	332.6	298.5	264.4	230.3	196.4	280	410
WN300 / WQ300	382.1	373.0	364.4	331.9	292.1	252.4	382.1	370.2	334.4	298.7	262.9	227.1	300	450
WN350 / WQ350	388.0	380.2	372.7	365.6	358.7	352.0	388.0	380.2	372.7	365.6	358.7	352.0	350	450

- 1) Load-bearing capacities apply both for Egcodorn WN and for Egcodorn WQ.
- 2) For simultaneous longitudinal and lateral movements reduced values apply.
- 3) The minimum slab thickness h_{min} applies for central positioning of the dowel in the slab.
- 4) If h_{max} is exceeded, an additional rebar splice with the horizontal legs of the anchorage body has to be arranged.
- 5) Additional top and bottom reinforcement should be used for the transfer of shear forces. U bars should also be used at the slab edge to anchor the additional reinforcement.
- 6) Cap stirrups pos. 2 Ø 10 necessary (see installation step 2).
- 7) The horizontal arm of the anchorage body has to be overlapped on site with a bare of the same diameter as the anchorage body. These bars have to be anchored outside of the control perimeter.



Individual component dimensions

Chart 2 – dowel dimensions

Type		40	50	70	95	100	120	150	210	300	350
D	[mm]	22	24	27	30	32	34	37	42	44	52
h_D	[mm]	80	100	120	140	140	170	170	200	240	240
a_r	[mm]	70	80	90	100	105	115	125	140	150	175
$a_{r,1}$	[mm]	110	120	140	150	160	170	190	210	230	260
h_{min}	[mm]	140	160	180	200	210	230	250	280	300	350

Chart 3 – required component part dimension

	Anchor body [mm]	10	12	14	16	20	25
d_s	[mm]	10	12	14	16	20	25
l_b	[mm]	156	187	218	250	312	390
h_{min}	[mm]	120	132	144	156	180	210
$h_{max}^{1)}$	[mm]	220	252	272	288	320	360
$l_c^{2)}$	[mm]	100	100	115	130	165	210
$h_{D,min}$	[mm]	60	72	84	96	120	150

- 1) Maximum slab height without the use of an overlap joint using the horizontal rebar at the sides of the shear force dowel
- 2) Support width on which calculations for shear check are based [mm].

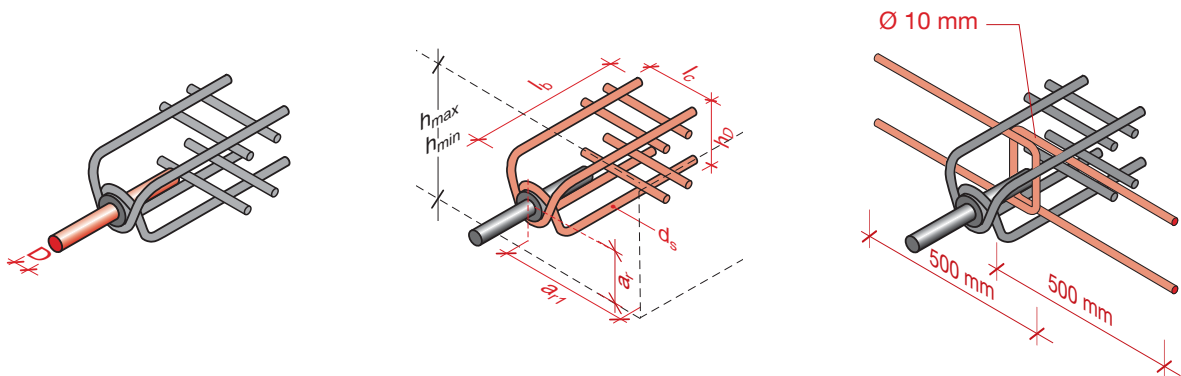

Dowel selection using joint width/dowel diameter

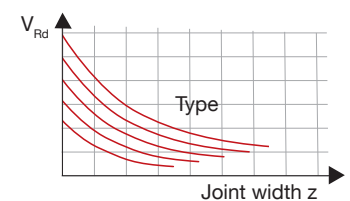
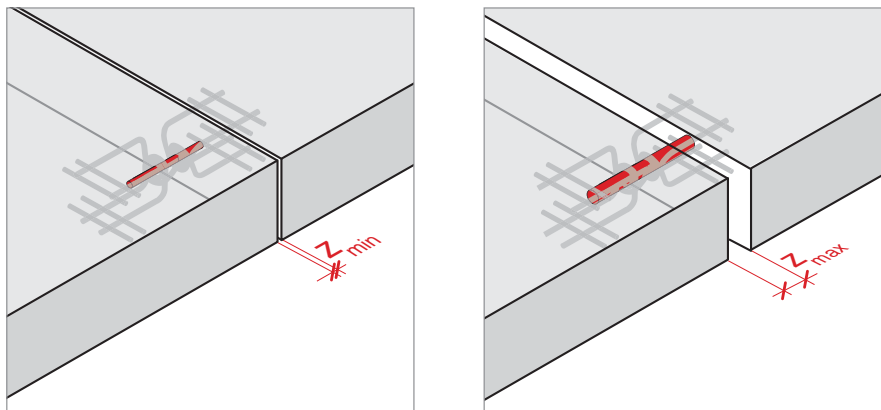

Optimum calculation with individual components

Chart 4 – bearing capacity $V_{Rd,s,0.90}$ [kN] longitudinal **or** transverse movement

$z \leq$ [mm]	Dowel diameter [mm]									
	22	24	27	30	32	34	37	42	44	52
10	92.4	113.9	150.3	191.7	222.0	254.6	307.7			
20	73.4	93.0	126.6	165.2	193.6	224.4	274.6			
30	54.5	72.2	102.9	138.7	165.3	194.1	241.5	331.6		
40	40.9	54.5	79.9	112.2	136.9	163.8	208.4	293.8	331.9	
50	32.7	43.6	63.9	89.8	110.5	134.1	175.3	255.9	292.1	
60	27.3	36.3	53.3	74.8	92.0	111.7	146.2	218.2	252.4	

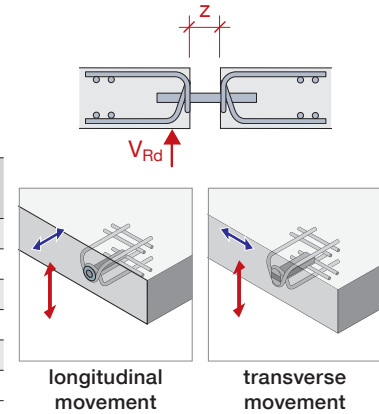

Chart 5 – bearing capacity $V_{Rd,s,0.81}$ [kN] longitudinal **and** transverse movement

$z \leq$ [mm]	Dowel diameter [mm]									
	22	24	27	30	32	34	37	42	44	52
10	83.1	102.5	135.2	172.5	199.8	229.2	277.0			
20	66.1	83.7	113.9	148.6	174.3	201.9	247.2			
30	49.1	65.0	92.6	124.8	148.7	174.7	217.3	298.5		
40	36.8	49.0	71.9	100.9	123.2	147.4	187.5	264.4	298.7	
50	29.5	39.2	57.5	80.8	99.4	120.6	157.5	230.3	262.9	
60	24.5	32.7	47.9	67.4	82.8	100.5	131.5	196.4	227.1	

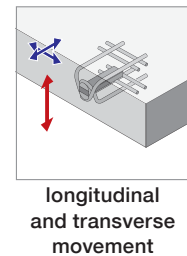

Chart 6 – anchor body diameter [mm]

$z \leq$ [mm]	Dowel diameter [mm]									
	22	24	27	30	32	34	37	42	44	52
10	14	14	16	20	20	25	25			
20	12	14	16	20	20	20	25			
30	10	12	14	16	20	20	25	25		
40	10	10	12	16	16	20	20	25	25	
50	10	10	12	14	16	16	20	25	25	
60	10	10	12	12	14	16	20	20	25	

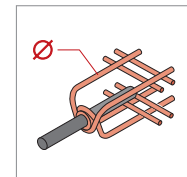

Chart 7 – predesign of slab bearing capacity

requ. a	d_s [mm]	h	existing V_{Ed} [kN]												
			20	30	40	50	60	70	80	90	100	110	120	130	140
			requ. a_s												
472	12	160	1.40	4.72	11.19	21.86	–	–	–	–	–	–	–	–	–
544	14	180	0.69	2.32	5.50	10.75	18.58	–	–	–	–	–	–	–	–
616	16	200	0.37	1.25	2.96	5.77	9.98	15.84	23.65	–	–	–	–	–	–
680	20	220	0.23	0.76	1.80	3.52	6.09	9.67	14.43	20.54	28.18	–	–	–	–
760	20	240	0.13	0.44	1.03	2.02	3.49	5.54	8.27	11.78	16.16	21.51	27.92	35.50	–
820	25	260	0.09	0.30	0.72	1.41	2.43	3.86	5.76	8.21	11.26	14.98	19.45	24.73	30.89
900	25	280	0.06	0.20	0.48	0.95	1.64	2.60	3.88	5.52	7.57	10.08	13.08	16.63	20.77
968	28	300	0.04	0.15	0.35	0.69	1.20	1.90	2.84	4.04	5.54	7.38	9.58	12.18	15.21
1048	28	320	0.03	0.11	0.25	0.49	0.85	1.35	2.02	2.87	3.94	5.25	6.81	8.66	10.82
1128	28	340	0.02	0.08	0.18	0.36	0.62	0.98	1.47	2.09	2.87	3.82	4.96	6.31	7.88
1208	28	360	0.02	0.06	0.14	0.27	0.46	0.73	1.09	1.56	2.14	2.84	3.69	4.69	5.86
1288	28	380	0.01	0.04	0.10	0.20	0.35	0.55	0.83	1.18	1.62	2.15	2.79	3.55	4.44
1368	28	400	0.01	0.03	0.08	0.16	0.27	0.43	0.64	0.91	1.24	1.66	2.15	2.73	3.42
1568	28	450	0.01	0.02	0.04	0.09	0.15	0.24	0.35	0.50	0.69	0.91	1.19	1.51	1.88
1768	28	500	0.00	0.01	0.03	0.05	0.09	0.14	0.21	0.30	0.41	0.54	0.70	0.89	1.11
1968	28	550	0.00	0.01	0.02	0.03	0.05	0.09	0.13	0.18	0.25	0.34	0.44	0.56	0.69
2168	28	600	0.00	0.00	0.01	0.02	0.04	0.06	0.08	0.12	0.16	0.22	0.28	0.36	0.45

Example: Slab-slab connection using a series of transverse shear force dowels

1 Installation situation

Selected: Egcodorn WQ

Dowel diameter: 24 mm
 Diameter of anchor body: 10 mm
 Diameter of cap stirrup: 10 mm
 Axle distance a: 80 cm

2 Conditions

Load and static system:

Determination of transverse force transmitted to each dowel:
 $G_k = 25.0 \text{ kN/m} \cdot 0.8 \text{ m} = 20.0 \text{ kN}$
 $Q_k = 17.0 \text{ kN/m} \cdot 0.8 \text{ m} = 13.6 \text{ kN}$
 $V_{Ed} = 1.35 \cdot 20 + 1.5 \cdot 13.6 = 47.4 \text{ kN}$

3 Material and slab dimensions

C25/30
 B 500
 $C_{nom} = 30 \text{ mm}$
 $Z_{max} = 40 \text{ mm}$
 (maximum joint width during product life)

Section

4 Dowel selection

Bearing capacity of the connection according to charts 5 and 6 (page 13)
 $V_{Rd,s} = 49.0 \text{ kN}$

Proof:

$$\eta = \frac{V_{Ed}}{V_{Rd,s}} = \frac{47.4}{49.0} = 0.97 \leq 1.0$$

Chart 5 – bearing capacity $V_{Rd,s,0.81}$ [kN] longitudinal **and** transverse movement

z ≤ [mm]	Dowel diameter [mm]									
	22	24	27	30	32	34	37	42	44	52
10	83.1	102.5	135.2	172.5	199.8	229.2	277.0			
20	66.1	83.7	113.9	148.6	174.3	201.9	247.2			
30	49.1	65.0	92.6	124.8	148.7	174.7	217.3	298.5		
40	36.8	49.0	71.9	100.9	123.2	147.4	187.5	264.4	298.7	
50	29.5	39.2	57.5	80.8	99.4	120.6	157.5	230.3	262.9	
60	24.5	32.7	47.9	67.4	82.8	100.5	131.5	196.4	227.1	

Chart 6 – anchor body diameter [mm]

z ≤ [mm]	Dowel diameter [mm]									
	22	24	27	30	32	34	37	42	44	52
10	14	14	16	20	20	25	25			
20	12	14	16	20	20	20	25			
30	10	12	14	16	20	20	25	25		
40	10	10	12	16	16	20	20	25	25	
50	10	10	12	14	16	16	20	25	25	
60	10	10	12	12	14	16	20	20	25	

Installation details

The main application purpose is to produce a slab/slab connection. The attached diagrams show additional typical applications. Our technical department can assist you in the planning of your project.

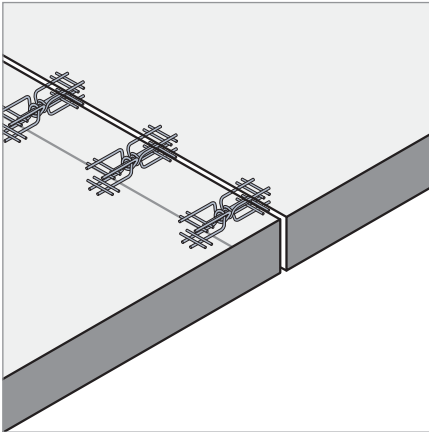

Slab / Slab

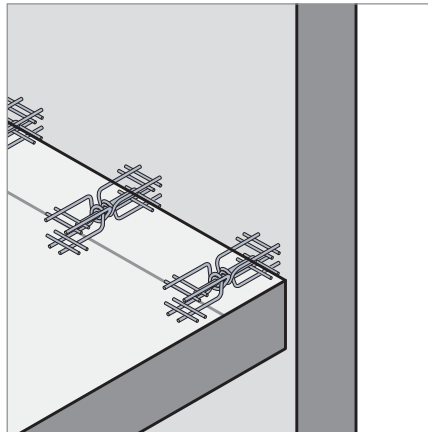

Wall / Slab

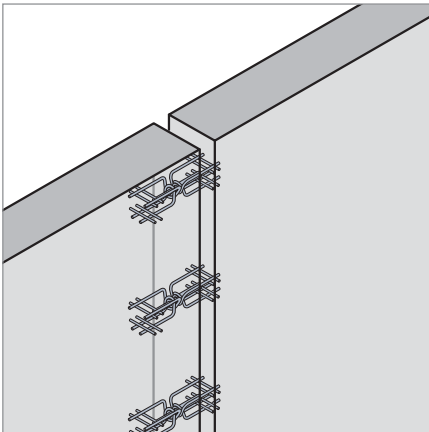

Wall / Wall

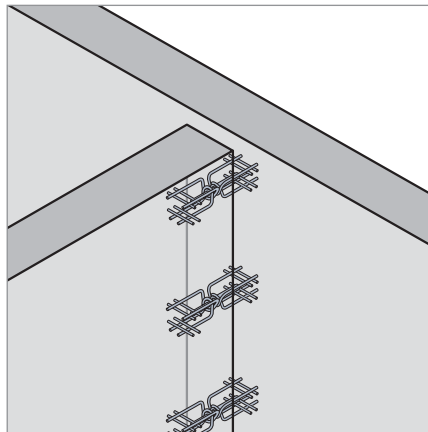

Wall / Wall

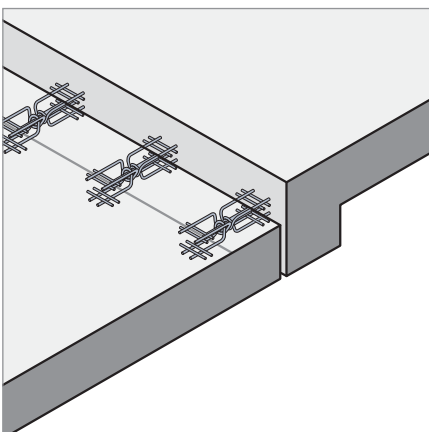

Girder / Slab

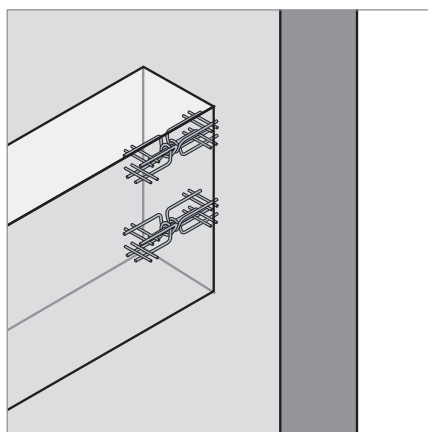

Wall / Girder

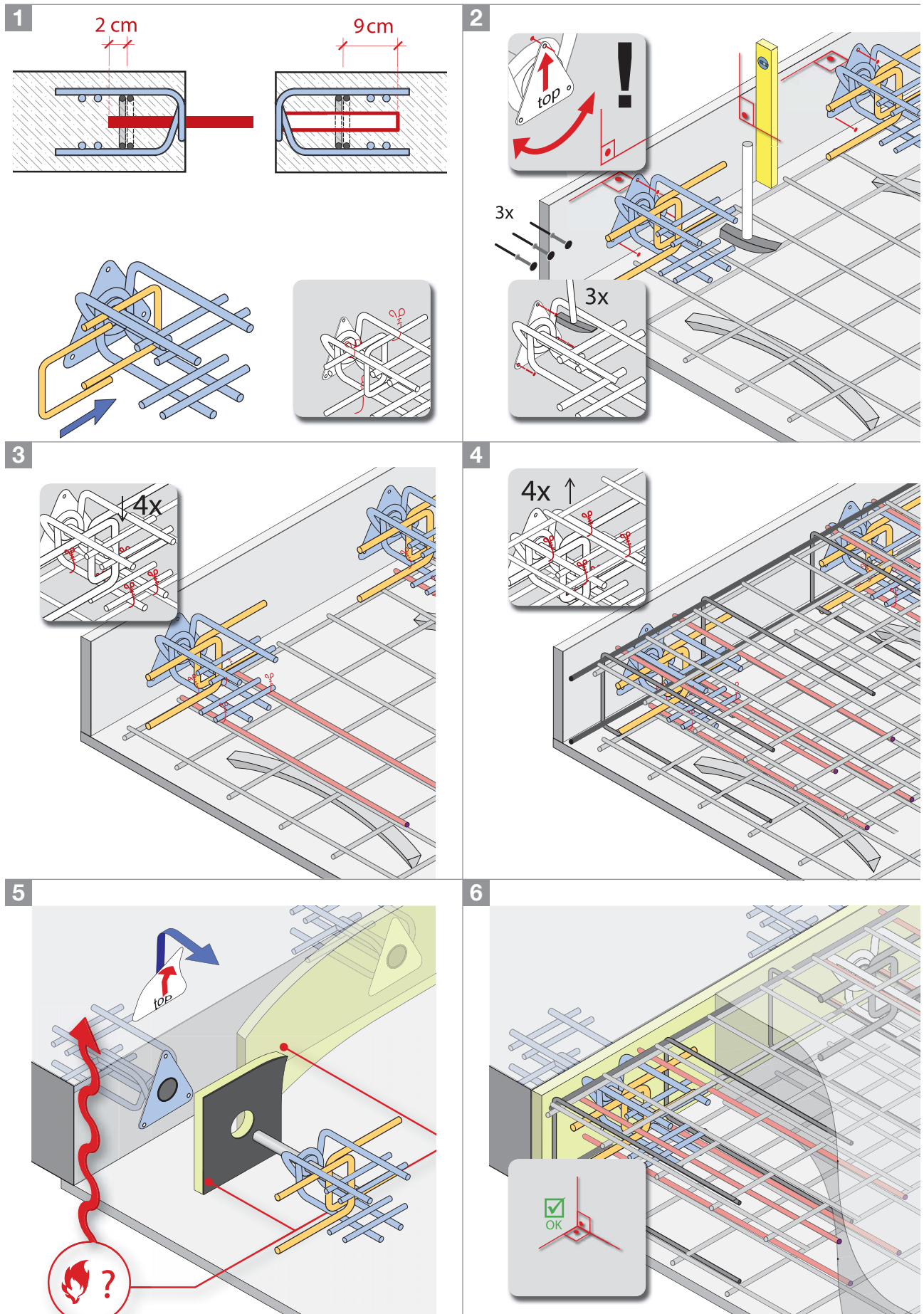

This Installation Guideline is a condensed description of factors having a direct effect on the performance of the FRANK products and is based on the present state of the art. It may be necessary to alter these recommendations, as more information becomes available. Correct use is the responsibility of the user, if in doubt please consult your local supplier.

Egcodubel for longitudinal movements

The Egcodubel with stainless steel sleeve is used in environments subject to high corrosion. The dowel core is made of structural steel quality S355 or it is available as high-grade material.

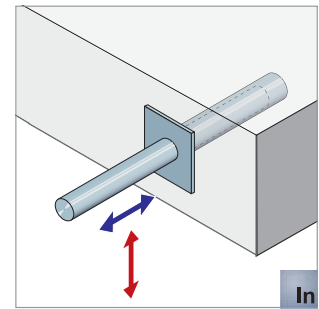

Egcodubel for longitudinal & transverse movements

For transmission of movements orthogonal to the dowel axle the Egcodubel can also be supplied with a sleeve allowing for transverse movements. All other properties are identical with the above described Egcodubel for longitudinal movements.

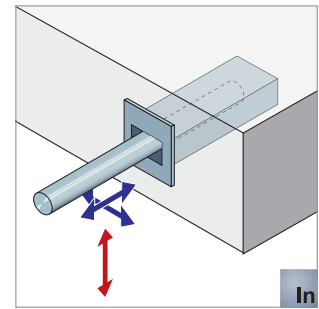



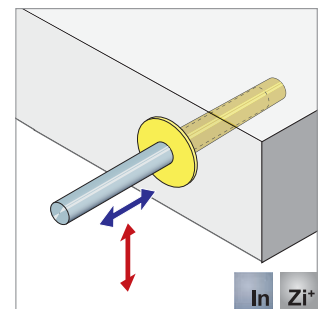

Egcodubel for longitudinal movements – plastic sleeve

The Egcodubel can be combined with a plastic sleeve for transfer of less important loads or for connection of structural elements. The galvanised type of Egcodubel is used for environments without exposure to corrosion.

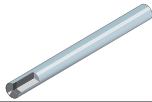
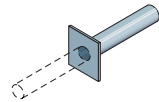

Type designation

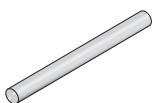
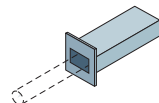
Example: Egcodubel EDM
 Egcodubel Type **27** Diameter **HF** Dowel core **HQI** Sleeve design¹⁾

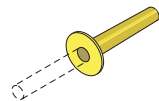
Dowel type		Dowel core/ Dowel material	Diameter [mm]	Length [mm]	Sleeve design			
Stainless steel 	EDM	HF	20	340	Stainless steel sleeve for longitudinal movement 	HI		
			22	350				
Galvanised ²⁾ 	EDV		25 ³⁾	360	Stainless steel sleeve for longitudinal and transverse movement 	HQI		
				27 ⁴⁾			360	
			30	400			Plastic sleeve for longitudinal movement up to max. Ø 30 mm 	H
			37 ⁴⁾	470				
		S355	20	300				
			22	300				
			25 ³⁾	300				
			27 ⁴⁾	300				
			30	350				

1) Optional, not necessary when dowel without sleeve is used.
 2) Types may only be combined with plastic sleeve.
 3) Only galvanised
 4) Only stainless steel

Egcodubel with stainless steel sleeve

Egcodubel systems can also be supplied without gliding sleeves to produce dowel connections between construction joints or contraction joints. For environments subject to strong corrosion, specifiers must use the dowel type with stainless steel sleeve.

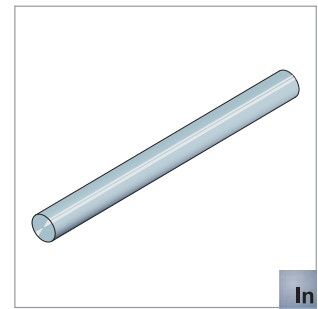

Egcodubel galvanised

If the concrete cover ensures sufficient corrosion protection, the galvanised Egcodubel type for construction joints or contraction joints is sufficient.

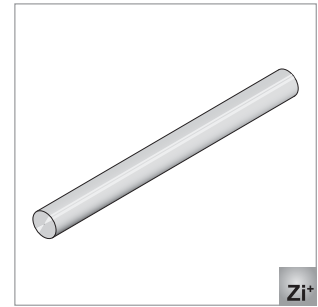

Egcodubel for absorption of forced stress (one end coated with soft plastic)

The galvanised Egcodubel is fitted with a half-sided coating made of soft plastic material for absorption of forced stress, e.g. stress caused by temperature influence.

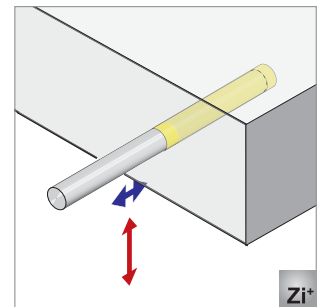

Type designation – Egcodubel for track slabs

Example: Egcodubel EDV **18** **S235** **E**
 Egcodubel Type Diameter Dowel core Expansion sleeve⁵⁾

Dowel type		Dowel core/ Dowel material	Diameter [mm]	Length [mm]	Coating ⁶⁾		
Galvanised EDV Zi+	S355	S355	20	500	half-sided coating, expansion sleeve 	E	
			22	500			
			25	500			
			18	500			
			20	500			
			22	500			
	S235	S235	S235	25	500	completely plastic coated ⁷⁾ 	B
				28	500		

5) Optional, dowel without expansion sleeve or coating

6) If coated no sleeve necessary.

7) Only available for dowel S235 diameter 25 mm

Egcodorn DND for dynamic loads

The special design of the Egcodorn DND also ensures transmission of fatigue loads.

Especially for use in joints exposed to any type of traffic that can induce dynamic loads and therefore they require extremely careful planning and project execution. Our technical experts shall be delighted to assist you in your planning. We have a vast experience of the design of joints to withstand dynamic loading.

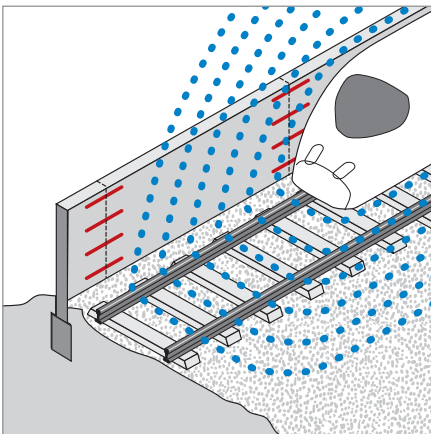

Sound protection walls for railway tracks

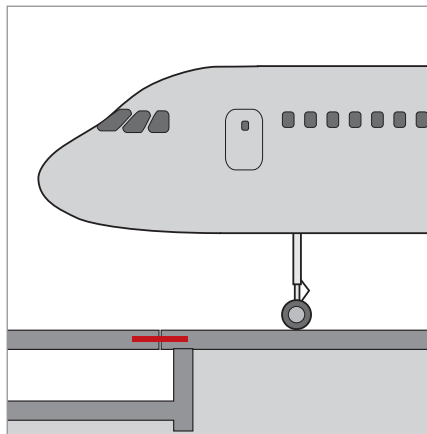

Contraction joints taxiways

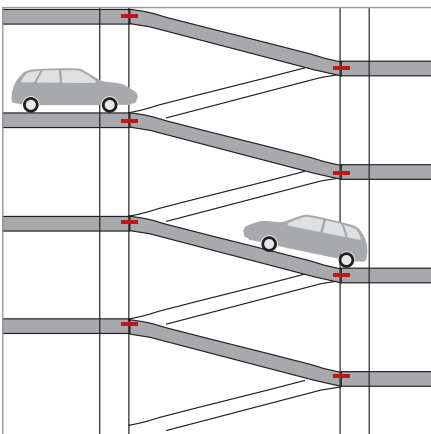

Ramp connection in multistorey car park

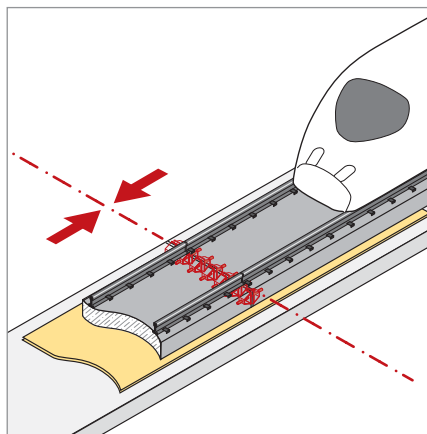

Mass-Spring-Systems for railway tracks

Mass-Spring-Systems

Joints are interlinked by Egcodorn DND dowels to minimize relative displacements between two adjacent roadway slabs.



Sound protection along the ICE rail track Cologne Rhine/Main

In the local area of the village Elz, sound protection walls were designed as highly absorbing walls.

A three-chamber system guarantees for highly efficient sound protection. The outside chambers are filled with a special grain made of limestone and they are backed with technical absorber plates. The reinforced concrete core does not only provide for sound insulation, but at the same time it absorbs static forces. Dynamic forces resulting from wind suction and wind pressure of trains passing by are absorbed by the reinforced concrete core as well.

The FRANK Egcodorn DND is used for transfer of dynamic loads in the joints of the reinforced concrete core. The Head Office of the German Federal Railroads in Frankfurt was in charge of assessment and approval of the relevant calculations.



Fire protection collar

Egcodorn or Egcodubel systems must be fitted with a fire protection collar to fulfil the requirements of fire protection. The fire protection collar is fitted at the construction site. The FRANK fire protection collar has been classified as having fire protection class R120.

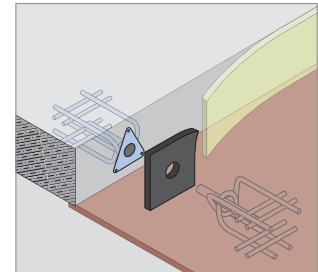
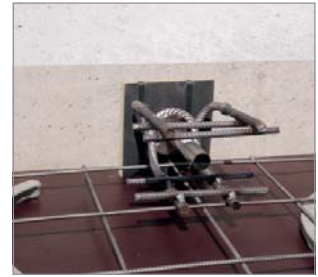

Egcodubel supporting systems

We manufacture a dowel support to your specifications for quick and secure fixing of Egcodubel systems in slabs with contraction joints. This allows both the distance between the dowels and the dowel installation height in the slab to be guaranteed by simple means and can be easily checked.

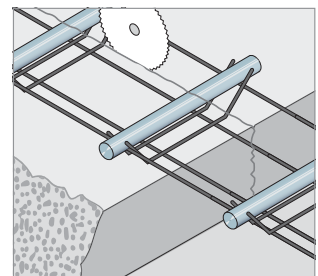
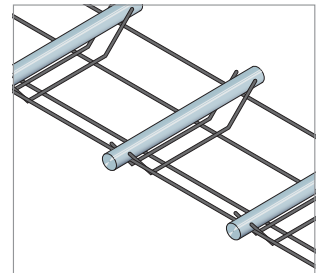

Stremaform® formwork element for expansion joints with Egcodorns or Egcodubels

Egcodorn dowels may be integrated in already manufactured Stremaform® formwork elements to ensure quick and efficient progress of works at the construction site. The units must be craned into position for safety.

Formwork elements can be fitted with joint supports to ensure joint sealing. Upon customer's request these joint sealants can already be installed in our factory. Where required, outside joint sealants including assembly supports are supplied to avoid joint contamination.

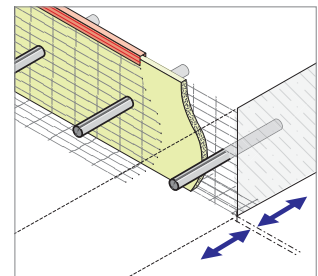
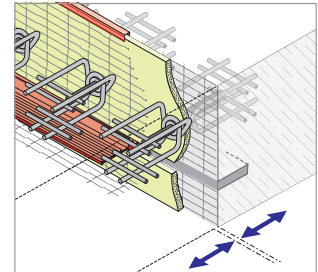
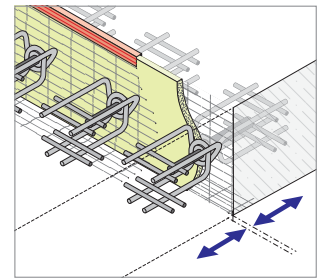
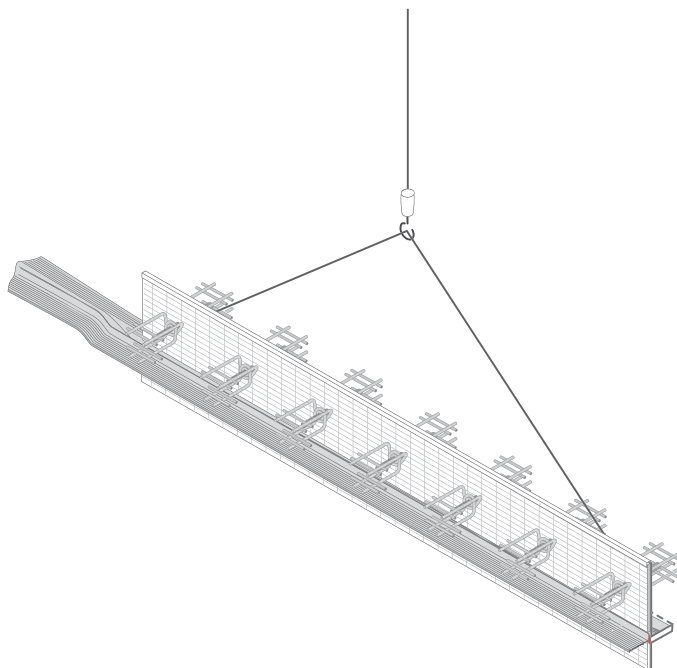

The following documents are available for download from our website:

- Egcodorn N and Q approval
- Egcodorn Q dimensioning example slab flank
- Egcodorn DND approval
- Egcodorn, Egcodübel, Egcotritt: Technical report on behaviour under fire



Max Frank GmbH & Co. KG

Mitterweg 1
94339 Leiblfing
Germany

Tel. +49 9427 189-0

Fax +49 9427 1588

info@maxfrank.com

www.maxfrank.com