

matki | S H O W E R I N G

**EAUZONE PLUS
REVERSE DOUBLE PANEL BATH SCREEN
MODELS: EPD900REV / EPD1000REV**

INSTALLATION

PARTS LIST

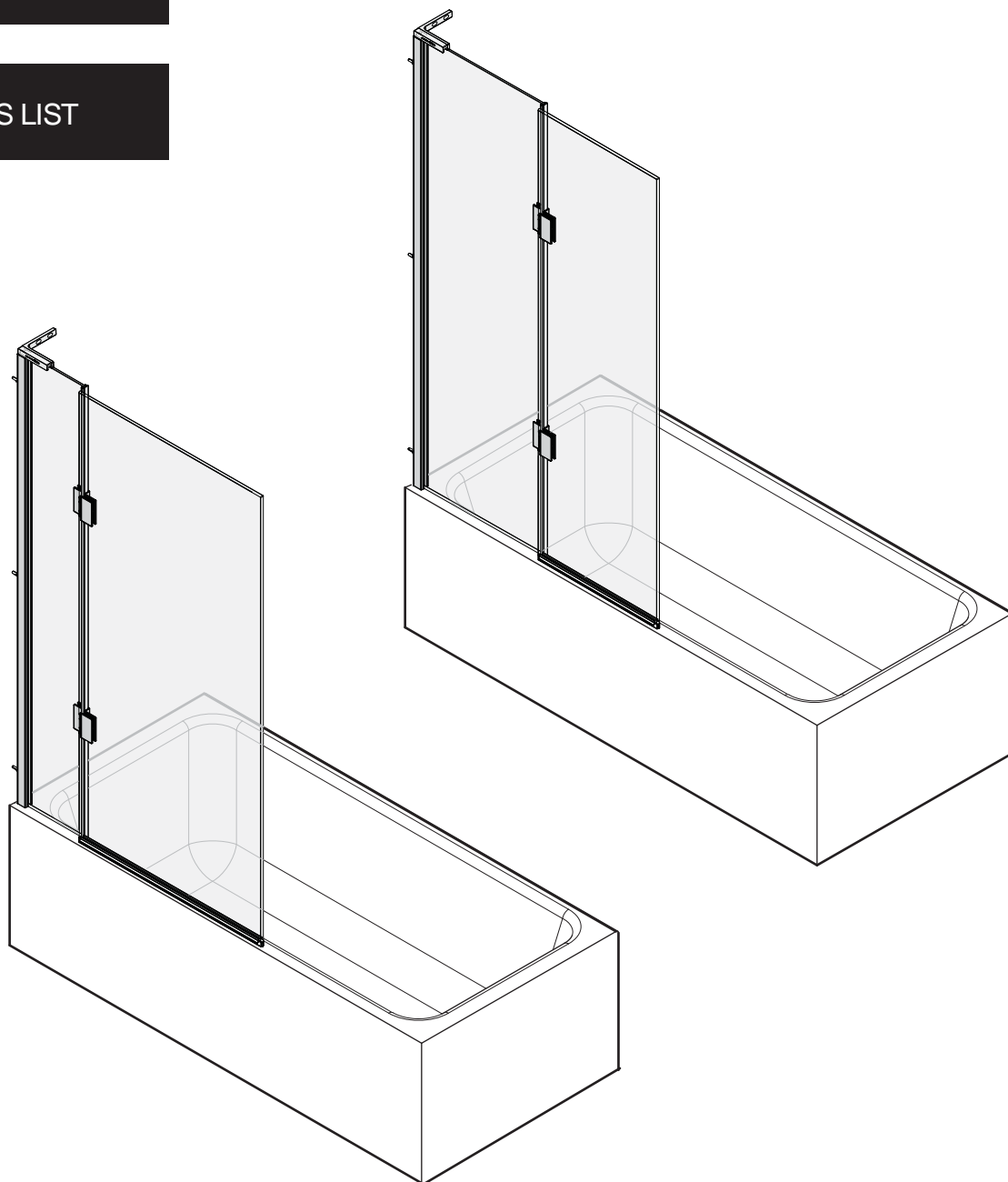

MATKI PLC, CHURCHWARD ROAD, YATE, BRISTOL, BS37 5PL
TELEPHONE:01454 328816 (AFTER SALES) FAX:01454 328821 EMAIL: techsupport@matki.co.uk

HANDING

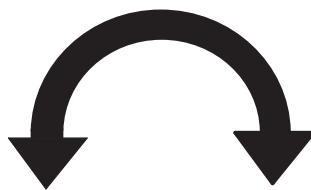

EPD1000REV LH

TURN PANEL 180 ° TO
CHANGE HANDING

EPD1000REV RH

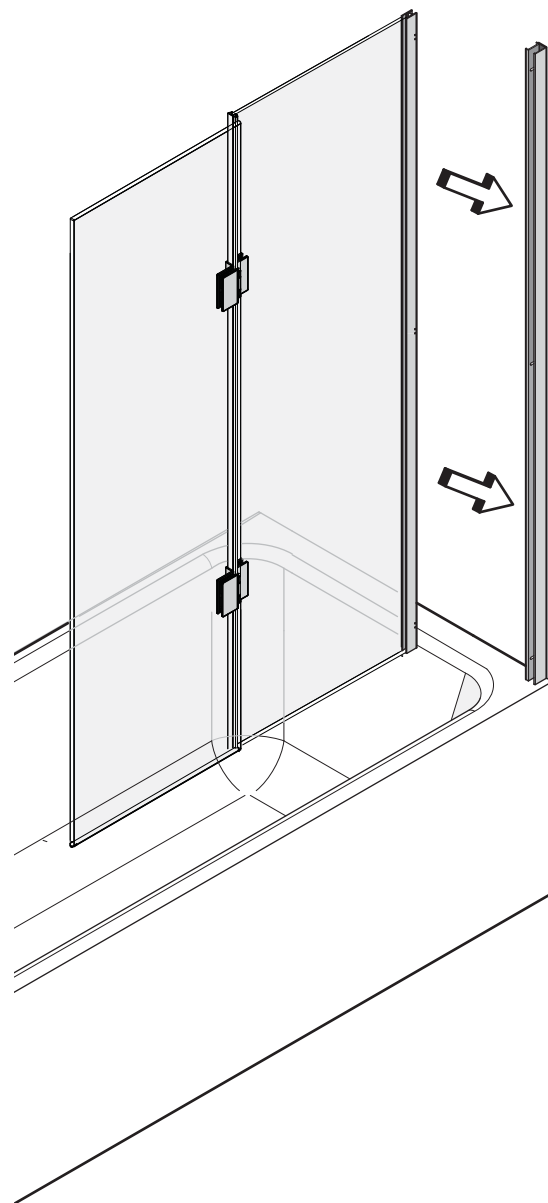
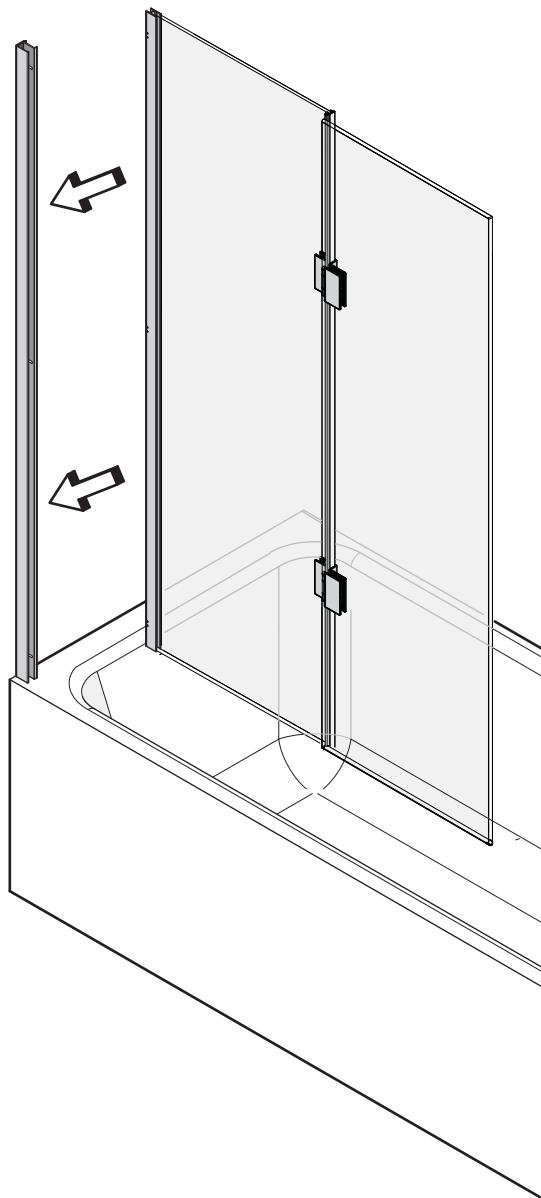

THE STAGES IN THIS INSTALLATION BOOKLET SHOW LH HINGED BATH SCREEN INSTALLATION, REVERSE FOR RH.

IMPORTANT

Before disposing of carton and/or commencing assembly, please check all the parts to ascertain that none are missing and they are all undamaged. No claim for missing/damaged parts will be accepted once the packing carton has been disposed of and/or assembly has commenced. In case of query contact your Stockist with details of model number and details of serial number.

PREPARATION IMPORTANT

1. Please read complete installation instructions before fitting the Bathscreen.
 2. We recommend the use of Safety glasses and Non slip gloves when handling the glass panels.
 3. Ensure that the product can be **fixed to a solid masonry wall** or suitable **timber stud work grade C16/C24** in the area behind the Wall frames and Panel fixing brackets.
 4. Seal between Bath and tiles. Remove any excess sealant from the area/joint between the Bath and the tiles where the Wall Mount is to be fitted. This will ensure the Wall mount fits correctly to the wall and Bath.
- CAUTION: TEMPERED GLASS CANNOT BE CUT, POLISHED METAL AND CHROME CAN BE SCRATCHED. CAREFULLY REMOVE ASSEMBLY FROM CARTON, DO NOT PLACE GLASS ON HARD FLOOR OR EXPOSE EDGES TO IMPACT.**

DIMENSIONS

TYPICAL INSTALLATION OF BATH SCREEN ON BATH

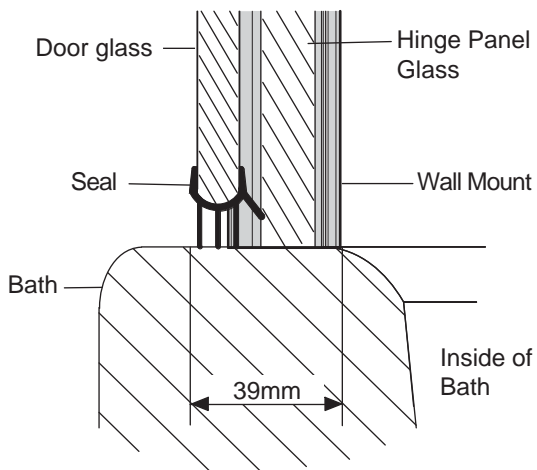

It is recommended to install the Bath screen wall mount close to the inside edge of the bath to reduce any unwanted water build up.

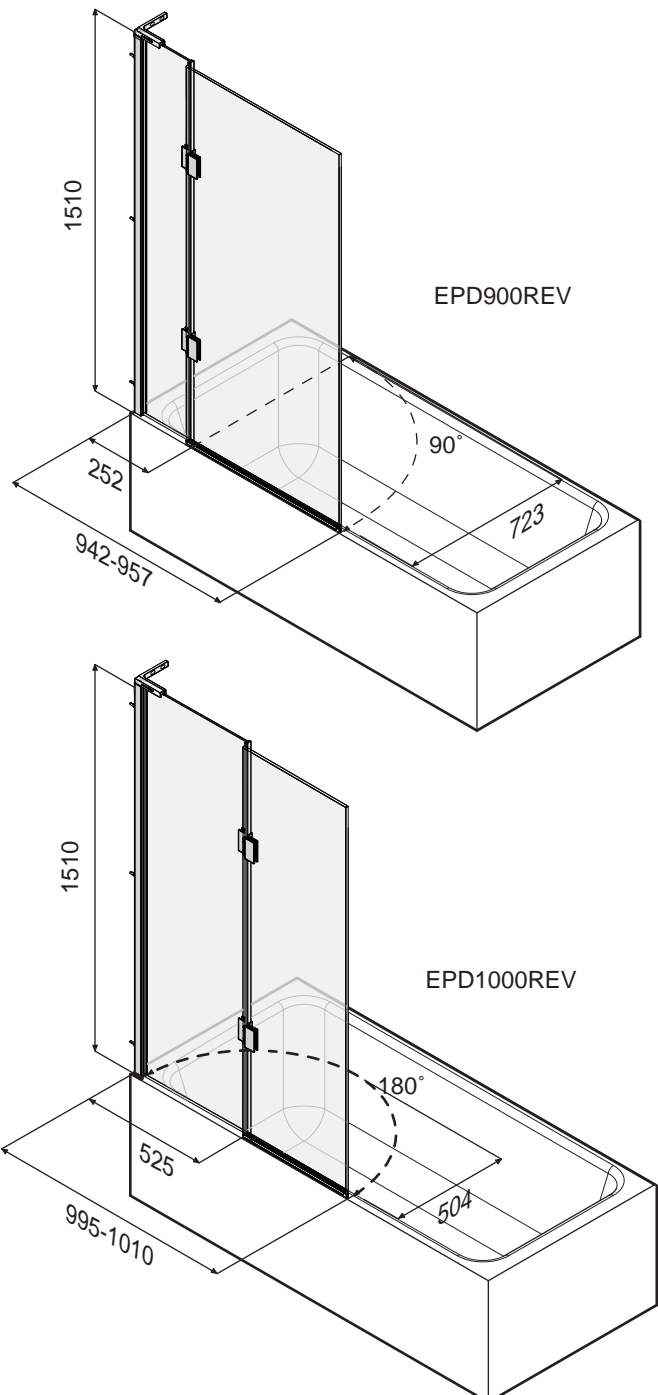

Dimensions are approximate due to nature of materials used

STAGE 1

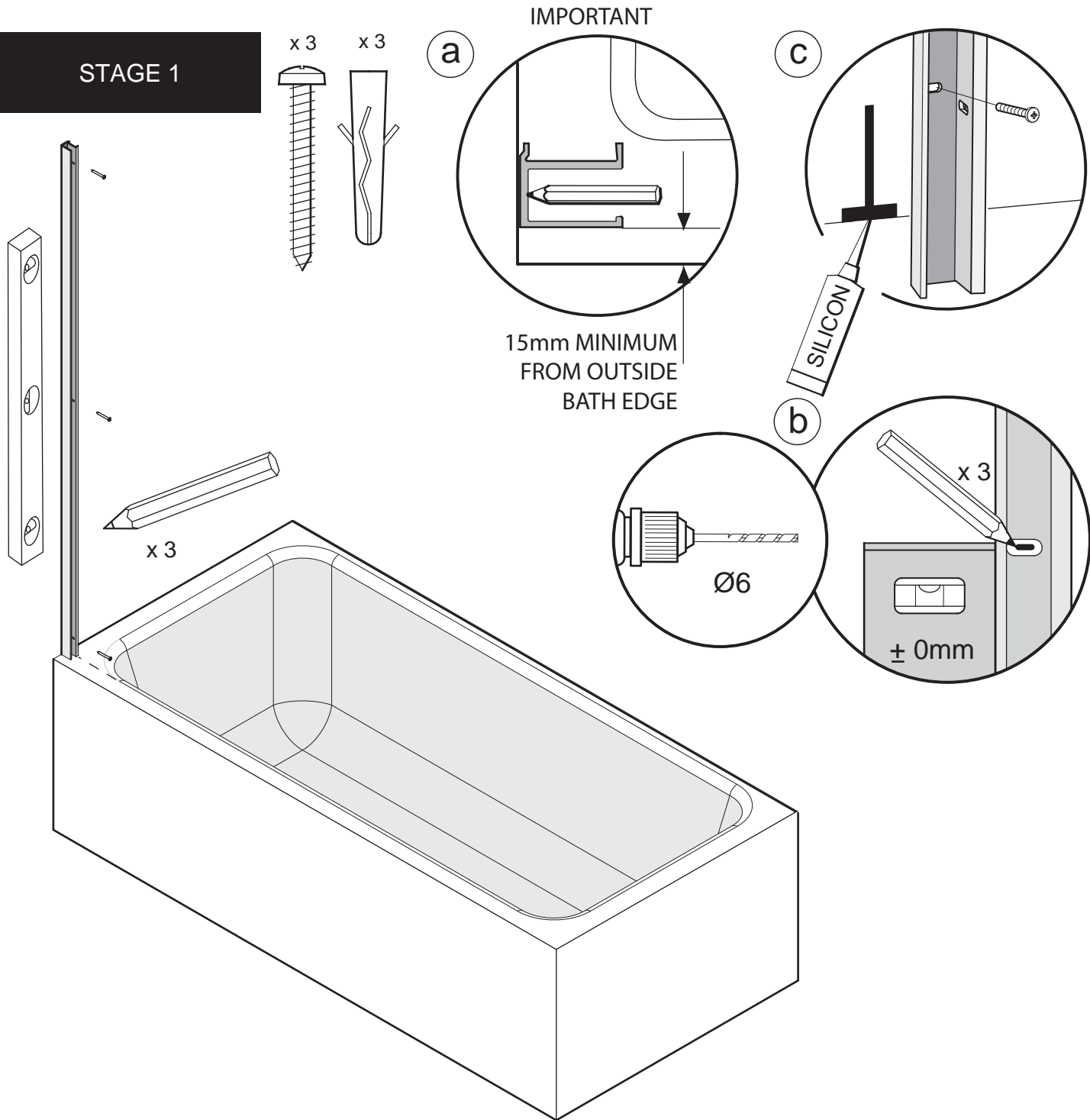

This stage is describing the fitting of the wall mount.

The wall mount is supplied assembled to the panel. Carefully remove the inside cover and wall mount adjustment screws and wall mount. Store the adjustments screws in a safe place for re assembly in Stage 2.

a. IMPORTANT. It is recommended that the wall mount is positioned so that the bath screen is close to the inside edge of the bath. This will help to reduce unwanted water build up. Position the wall mount so that the adjustment slots on the side of the wall mount are facing inside the product.

b. Plumb the wall mount for upright and mark the fixing holes in the centre of the slots. Drill 3 x fixing holes in the wall and insert the wall plugs.

c. Clean the area and apply silicon sealant to the area behind the wall mount between the bath and tiles and 100mm up the wall, central to the width of the wall mount. Secure the wall mount using the No.8 x 32mm pan head screws, plumb the wall mount for upright do not over tighten the screws to allow for adjustment.

STAGE 2

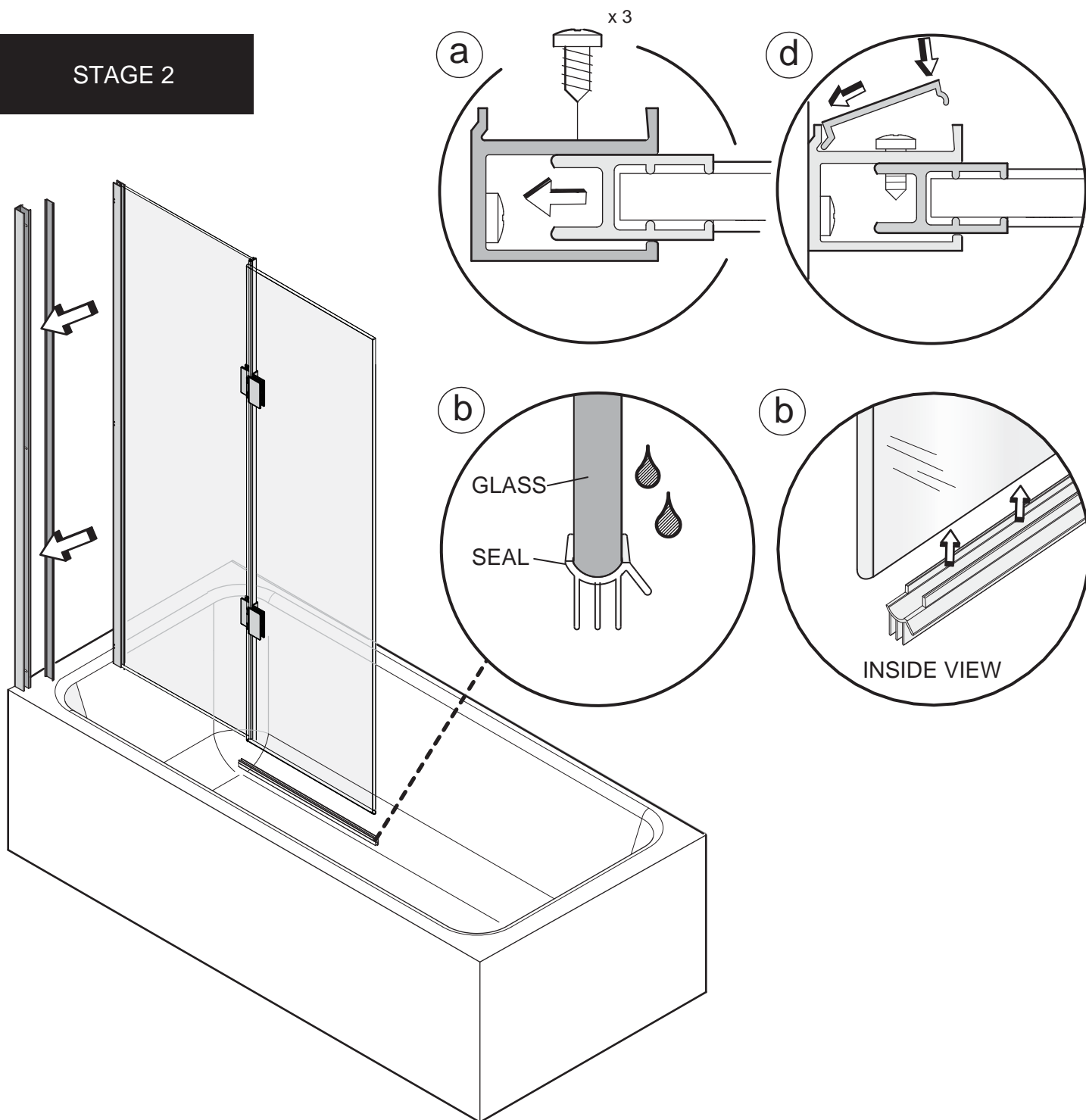

This stage is describing the fitting of the hinge panel, horizontal seal and adjustment.

IMPORTANT: There is no adjustment in the Bath Screen hinges.

- Fit the bath screen to the wall mount and secure with the No.8 x 9.5 pan head adjustment screws.
- Fit the bath screen horizontal seal to the bottom edge of the hinging panel with the deflector edge on the inside of the glass panel. Push fit the seal onto the glass so that the end of the seal is flush with the end of the hinge panel glass where it meets the vertical hinge seal.
- Adjust the bath screen within the wall mount so that the horizontal seal just touches the top of the bath. The horizontal seal can also be pulled down from the moving glass panel as required.
- When adjustment is complete fit the wall mount cover to the inside of the wall mount.

STAGE 3

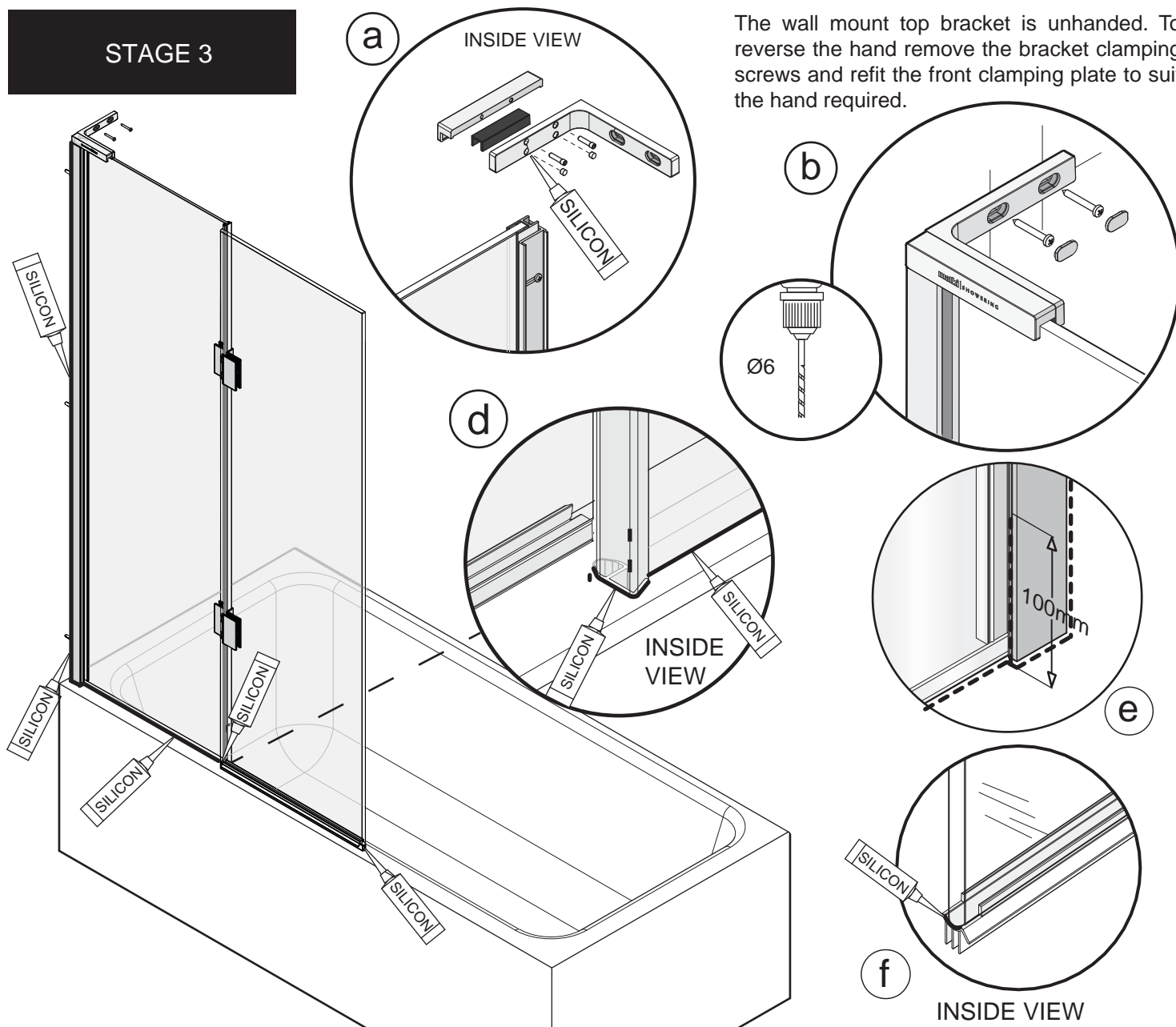

The wall mount top bracket is unhandled. To reverse the hand remove the bracket clamping screws and refit the front clamping plate to suit the hand required.

This stage is describing the fitting of the wall mount top bracket and application of silicon sealant.

a. Fit the rubber ' U ' shaped gasket onto the top edge of the glass with the grooved face of the gasket facing outwards. Fit the wall bracket over the glass and onto the top of the wall mount.

b. Mark the centre of the slotted holes in the wall bracket onto the wall. Remove the wall bracket and drill and fix the wall plugs. Refit the wall bracket. Clamp the bracket onto the glass by tightening the clamping screws on the inside of the bracket. Fit the clamping screw cover caps into the two unused holes on the inside of the wall bracket. Apply a small spot of silicon in the holes before fitting the caps.

c. Fix the bracket to the wall using the No.8 x 50 Pan head screws and fit the bracket screw cover caps.

d. Apply a thin bead of silicon sealant on the outside along the bottom edge of the wall mount and fixed panel glass where it meets the bath. Continue the sealant around the base of the vertical hinge seal, insert a small bead into the end of the vertical hinge seal hollow bubble where it meets the bath.

e. Apply silicon sealant 100mm up the joint between the wall mount and the fixed glass panel adjustment frame. Apply silicon sealant all the way up the outside of the wall mount extrusion between the wall mount and tiles.

f. Apply a small spot of silicon sealant at both ends of the horizontal seal between the bottom edge of the glass panel and seal. Position the hinge panel in the open position along the bath and allow for the silicon sealant to cure.

Masking tape can be used to achieve a tidy edge to the sealant. Remove the masking tape immediately and allow the silicon to cure for 24 – 48 hours before using the shower.

PARTS LIST

EPD PARTS LIST				
ITEM	DESCRIPTION	PART No.	QTY	LENGTH
1	WALL MOUNT VERTICAL FRAME	7441 A SILVER	1	
2*	EPD 900 BATH SCREEN FIXED PANEL	8182 M CLEAR/PLAIN	1	
2*	EPD 1000 BATH SCREEN FIXED PANEL	8183 M CLEAR/PLAIN	1	
3	WALL MOUNT COVER	7443 A SILVER	1	
4	EPD OUTWARD OPENING HINGE ASSEMBLY	7293 AF	2	
5*	EPD 900 BATH SCREEN HINGE PANEL	8179 M CLEAR/PLAIN	1	
5*	EPD 1000 BATH SCREEN HINGE PANEL	8181 M CLEAR/PLAIN	1	
6	WALL MOUNT	7442 A SILVER	1	
7	EPD TOP AND BOTTOM VERTICAL SEAL	2381 CLEAR	2	375mm
8	EPD CENTRE VERTICAL SEAL	2380 CLEAR	1	691mm
9	No.8 x 9.5 PAN HEAD SELF TAPPING SCREW	1420 A SILVER	3	9.5mm
10	EPD WALL BRACKET AND PARTS KIT	7298 AF	1	
11*	EPD 900 HORIZONTAL SEAL	2375 CLEAR	1	700mm
11*	EPD 1000 HORIZONTAL SEAL	2377 CLEAR	1	480mm
12	CLEAR SILICON SEALANT 78g	1967 AF	1	
13	EPD INSTALLATION INSTRUCTIONS	0965 AF	1	
14	GUARANTEE BOOKLET	1061 AF	1	

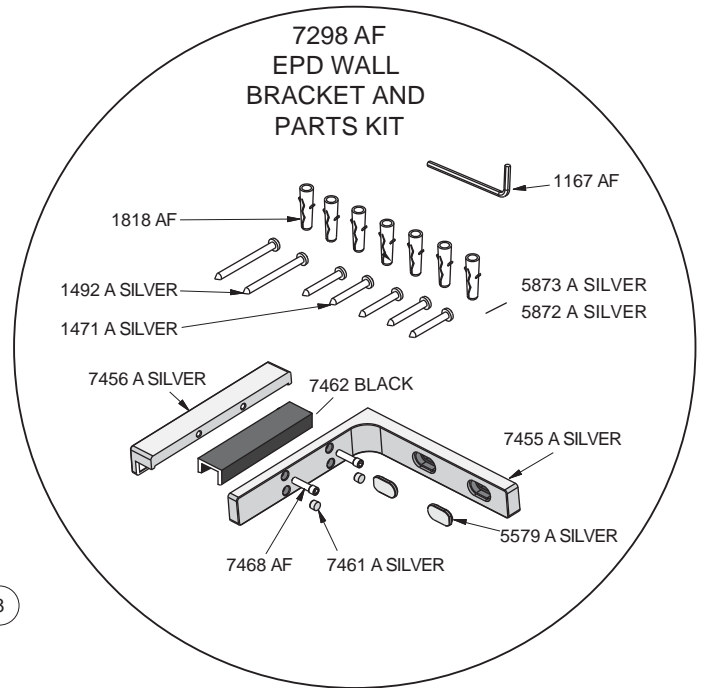
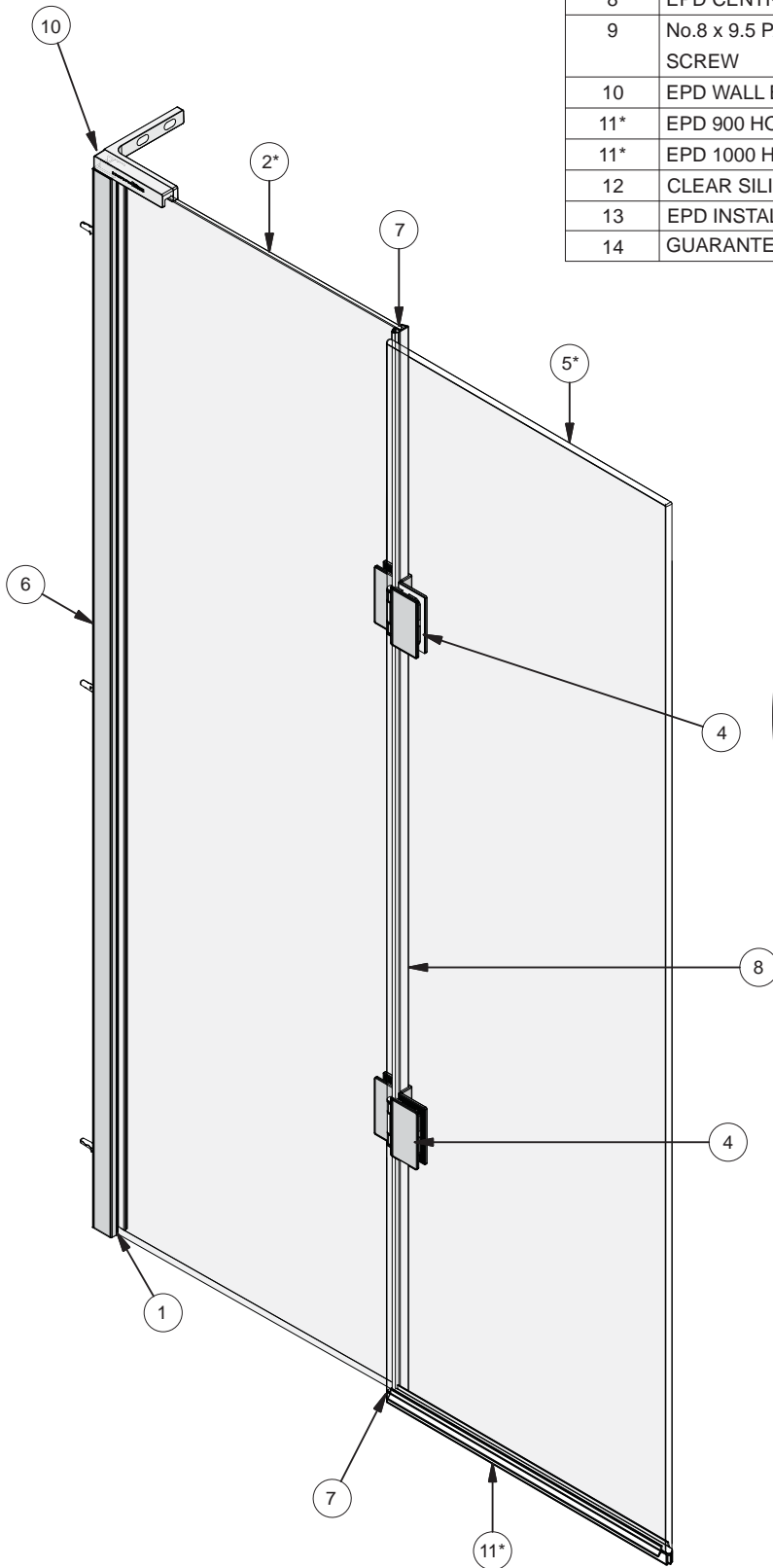

MAINTENANCE

Matki Glass Guard Easy Clean Surface Protection (optional) and General Cleaning Guide

Cleaning Instructions

Matki Glass Guard allows water to form minute beads which easily trickle off the surface of the glass. This makes the glass easier to clean - the glass does not need to be cleaned as frequently, but it does require occasional maintenance. As less cleaning is required the use of detergents can be minimised thus helping to protect the environment. The lifespan of the Matki Glass Guard is dependant on the frequency of use of the shower and the degree of water hardness.

The combination of alkaline materials and humidity affects glass in an extremely aggressive way. Do not use bleach, alkaline, acid-based or aggressive and abrasive glass cleaners, detergents or household cleaning products on the glass or frames.

We recommend that glass is washed down with clean water and a soft clean cloth or sponge and dried off with a microfibre cloth.

The special coating is only present on the inside of the glass.

Matki Glass Guard is guaranteed for 2 years provided that the guidelines and cleaning instructions are followed.

Aluminium and Chrome parts should be cleaned with a mild non scratch household cleaner and a soft cloth or sponge.

Do not use acidic-based descaler products or products which are unsuitable for cleaning enamelled surfaces, including abrasive cleaners or cleaners containing bleach or solvents, as the products will effect the anodised framework. Under no circumstances use cleaners with a pH level exceeding 8.

Matki does not recommend the use of 'Leave-on' shower cleaners on Matki Glass Guard Products.

Water Softeners and Glass Guard - Certain types of water softeners increase the alkalinity of the water due to a carry-over of Chloride during re-generation which can cause aggressive water spots on both untreated and Glass Guarded glass. If using a water softener we recommend a two-cylinder machine with automatic re-generation instead of a timer.

If a single-cylinder water softener with timer is already installed it is recommended that after each shower excess water is removed from the glass with a squeegee or with a micro-fibre cloth.



Wash down with clean warm water and a soft clean cloth or sponge.



Do not use bleach, alkaline or acid-based, aggressive or abrasive cleaning products.

Flash Bathroom Spray or Cif Bathroom Spray can be used on Matki Products.

Various specialist cleaning and glass dressing products are available from Ritec International Ltd Tel. 020 8344 8210 or www.ritec.co.uk.

Matki Plc is not connected with Ritec International Ltd in any way and the contact details are supplied for information only. Read manufacturers label before using any cleaning materials.

IMPORTANT

Matki Glass Guard is guaranteed for 2 years. It is essential that the cleaning instructions are followed in order to maintain the hydrophobic properties of the glass coating. In the event of the failure to comply in any way with these instructions, any warranty or guarantee will be null and void.

MATKI PLC, CHURCHWARD ROAD, YATE, BRISTOL, BS37 5PL
TELEPHONE:01454 328816 (AFTER SALES) FAX:01454 328821 EMAIL: techsupport@matki.co.uk



matki | SHOWERING
13
Matki PLC, Churchward Road, Yate,
Bristol BS37 5PL

EN 14428:2008+A1