



# Fibre cement slates fixing guide

# Introduction

Marley Eternit, a market leader in the design and manufacture of roofing products, offers high quality, durable fibre cement slates in a variety of colours, sizes and textures. Marley Eternit slates are manufactured from Portland cement, water, man-made and natural fibres. They are complemented by a wide range of ridges, double blanks for details at verges, hips and valleys, together with fixings and accessories for all roofing applications.

The range is as follows:

**Rivendale:** A finely detailed surface and dressed edges that together reproduce the attractive appearance of natural slate.

**Birkdale:** A smooth surface and dressed edges offer a traditional and pleasing look. Available for pitches down to 15°.

**Garsdale:** A detailed surface and square edge closely resembles natural slate, but is easier and faster to install.

**Thrutone:** A smooth surface and square cut edges give a low profile slate at an economical price which can be used on pitches as low as 15°.

Contents	Page
Slate dimensions, lap, gauge and estimating	3
Lap and pitch	4
Underlay	6
Battens	7
Materials and storage	8
Site working	9
Setting out	10
Nail and rivet fixing	11
Hook fixing	17
Universal 10 & 25mm eaves vent	22
Standard eaves	24
Slate verge trim	28

This Guide shows a range of standard detailing, dry fix and ventilation solutions. Fibre cement slates are equally complemented by fibre cement, clay and concrete fittings.

For more information, please contact our Technical Advisory Service.

This fixing guide contains detailed advice on good site practice to comply with the requirements of the Building Regulations, BS 5534 and BS 8000: Part 6, and is intended for general applications where Marley Eternit Slates are used.

Where non-standard situations occur, users must satisfy themselves as to the suitability of the recommendations given.

# Slate dimensions, lap, gauge and estimating

Marley Eternit slates are suitable for roof pitches of 15° and above and for vertical cladding.

Marley Eternit slates with a rivet and nail fixing are generally suitable for roof pitches of 20° and above and vertical cladding. Birkdale fixed with 150mm long slate hooks can be laid down to 15° and Thrutone nailed and riveted at 110mm headlap can be laid down to 15° at a maximum 4m rafter length.

Table 1: Slate dimensions

Size of slate (mm)	Typical Laps (mm)	Gauge of battens (mm)	Battens per m <sup>2</sup>	No. of slates (per m <sup>2</sup> )	Weight of slates as laid (kg/m <sup>2</sup> )
600 x 300	150	225	4.45	14.7	22.6
600 x 300	110	245	4.08	13.6	20.9
600 x 300	100	250	4.00	13.4	20.4
500 x 250	100	200	5.00	19.6	20.9

## Estimating

Basic information regarding the stated sizes and laps for estimating purposes is given in Table 1, above. These are approximate values.

To calculate the number of doubles required for verges, divide the rafter length by the batten gauge. Round up to a whole number and divide by 2 as they are on alternate courses. Multiply by the number of verges.

For example, for a rafter length of 10m, a batten gauge of 250mm and 4 verges, the following calculation would apply.

$$10 \div 0.25 = 20 \times 4 \text{ verges} = 80 \text{ doubles}$$

# Lap and pitch

The appropriate lap will depend on the pitch of the roof, together with other factors such as the exposure of the site, the length of the rafters and other design considerations.

Where abnormal conditions may be expected, e.g. on elevated sites, near the coast or in localities where heavy falls of snow are common, the lap treatments will vary. Refer also to BS 5534.

Table 2: Lap treatments

Size of slate (mm)	Typical Laps (mm)	Moderate exposure rafter pitch	Severe exposure rafter pitch
600 x 300	110	23° and over	26.5° and over
600 x 300	100	23.5° and over	29.5° and over
500 x 250	100	23.5° and over	29.5° and over

## Low pitch lap treatments

Slate	Roof pitch	Fixing	Max. rafter length	Headlap
Thrutone	15° - 17.5°	Nail & Rivet	4 metres	110mm
Birkdale	15° - 20°	Hook	6 metres	150mm

The discharge of rainwater from gutters and downpipes, from one roof to a low pitch fibre cement roof (15° max. 4m rafter length) is not recommended and should not be specified. Skylight roof windows and other penetrations should not be specified or constructed with a low pitch fibre cement roof (15° max. 4m rafter length).

Table 3: Windloading

Size of slate	Maximum wind suction loading*
600mm x 300mm	2000 N/m <sup>2</sup>
500mm x 250mm	2500 N/m <sup>2</sup>

\* When using two 30mm x 2.65mm long copper nails with copper disc rivet (19mm x 2mm stem, 19mm dia x 0.5mm thick base) in accordance with BS 5534.

# Underlay and battens

## Underlay

Due to the lightweight nature of installed slates underlay should be selected in accordance with the current BS 5534 and follow the manufacturer's recommendations.

Underlays draped over rafters (i.e. not fully supported) should meet the requirements of BS EN 13859-1 or BS 5534 Annex A (reinforced bitumen underlays) with appropriate third party accreditation e.g. BBA certificate.

The vertical laps of the underlay should be a minimum of 100mm.

The horizontal laps of the underlay should be as per Table 4 below. Each end of the underlay should be securely fixed over the rafters.

Table 4: Horizontal laps of underlay

Pitch	Minimum horizontal lap	
	not fully supported	fully supported
15° up to 34°	150mm	100mm
35° and above	100mm	75mm

## Using slates with a vapour permeable (LR) underlay

In accordance with the recommendations of BS 5250 Annex H, where Marley Eternit fibre cement slates are installed above a vapour permeable underlay (Type LR), provision must be made to ventilate the batten/counterbatten space beneath the slates (in addition to any loft ventilation), so as to prevent the risk of excessive condensation. Such a ventilated space should be achieved by means of counterbattens and vents at both high and low level. Low level vents should be equivalent in free area to a slot 25mm deep running the whole length of the eaves. High level vents should be equivalent in area to a slot 5mm deep running the whole length of the ridge. Alternative means of ventilation should provide an equivalent level of ventilation.

## Battens

Battens should comply with BS 5534 and be of graded softwood timber not less than 1200mm in length. They should be free of any sign of decay, insect attack, splits, shakes, knots or knot holes greater in size than one third of the width of the batten. The ends of each batten should always be fully supported.

In most cases, irrespective of rafter spacings, 50 x 25mm battens should be used for our standard preholed fibre cement slates.

Where BS 5534 suggests 38 x 25mm battens are acceptable, the slates should only be laid with 100 or 110mm lap.

Table 5: Batten size

Rafter spacing (mm)	Minimum batten size (mm)
Up to 450	38 x 25
451 - 600	50 x 25

# Materials and storage

## Nails, rivets, screws

Slate nails: nails for fixing slates should be 2.65mm (12 swg) Marley Eternit Slates jagged copper nails, 30mm long.

Batten nails: nails for fixing battens should be in accordance with BS 5534.

Slate rivets: copper disc rivet, 19mm x 2mm stem, 19mm dia. x 0.5mm thick base.

Screws: 60mm x 6.3mm self-sealing, nylon headed screws  
Longer screws may be required for different applications. (Screws only used with fibre cement ridges).

## Lead

When lead is used for flashings and soakers, lead oxide carried in the water run-off is likely to stain the slates. To avoid this, apply 'Patination Oil' to the lead immediately after it is fixed.

Information on the supply of patination oil can be obtained from British Lead, Telephone 01707 324595.

For details of all leadwork, flashings and 'Patination Oil' please consult the Lead Sheet Association, Telephone 01622 872432.

## Storage of slates

Slates should not be allowed to become wet when in packs or banded together, as efflorescence and staining can occur.

Storage inside: a building or similar shelter: the polythene hoods covering the slates should remain as a temporary protection to the slates, provided no water vapour can enter from below the packs.

Storage outside: remove the polythene hoods and stack the slates in bundles off the ground and cover with a good tarpaulin allowing clearance between the tarpaulin and the slates. This will allow free air movement and help prevent condensation forming within the pack (which could cause efflorescence).

If the slates are to be stored outside for a very short period of time, then the sides of the hood should be split open before covering with a tarpaulin to reduce the risk of condensation in the packs.

On larger contracts, it is better to avoid storing too many packs on-site and to schedule deliveries of slates as they are required.

# Site working

Slates should be fixed in accordance with BS 5534 'Code of practice for slating and tiling (including shingles)' and BS 8000-6 'Workmanship on building sites 'Code of practice for slating and tiling of roofs and claddings'.

Slates should be scored using a scribing tool and snapped over a straight edge.

Slates can be cut using a normal handsaw/hacksaw with teeth of 3mm - 3.5mm pitch, preferably wide set. Saws should always be used to start off when cutting acute angles.

Marley Eternit slates may be cut with a reciprocating saw. The use of angle grinders is not recommended for cutting as these tools can raise nuisance dust levels and are unnecessary.

Additional fixing holes should be drilled using a 4.0mm dia. standard drill bit. **Fixing holes must not be punched.**

After cutting or drilling, remove cutting dust from the slate to avoid subsequent staining.

Marley Eternit slates should not be cut with a slater's axe.

Note: consideration can be given to sealing any cut edges to prevent potential efflorescence staining. Contact Technical Advisory Service for further details

As this product is made mainly of natural raw materials, it can contain traces of quartz.

Mechanical machining (cutting, sanding, drilling) of this product can release dust which may contain quartz particles. We therefore request that the following general and personal protection measures are always used:

1. Avoid the generation of airborne dust by using tools with built-in dust extraction.
2. Ensure that adequate ventilation is provided at the work place.
3. Avoid contact with eyes and skin and avoid inhalation of dust by wearing appropriate personal protection equipment (safety goggles, protective clothing and a dust mask of at least type P2).

For further information, please contact the Marley Eternit Technical Advisory Service on 01283 722588.

# Setting out

## Setting out of battens

Roofs should be set out with battens, to the appropriate gauge. Select the appropriate gauge for the slate size by using the formula:

$$\text{gauge} = \frac{\text{length of slate} - \text{lap required}}{2}$$

Allow the eaves slates to overhang into the gutter by approx. 50mm. The verge overhang should be restricted to a maximum of 50mm.

Care must be taken when setting out to avoid the need for rectangular cut slates less than half the width of the slate to be used as it may be difficult to fix.

A vertical or raking batten is advisable at the verge and at intersections.

# Nail and rivet fixing

## Introduction

- All slates should be fixed in accordance with BS 5534 and BS 8000-6
- Slates should be laid broken bond using slate-and-a half width slates in alternate courses formed from double width slates at verges, hips, valleys and abutments.
- Allow a 5mm gap between adjacent slates for disc rivet shank
- Nail slates firmly but do not drive nails too tight to the surface of the slate
- For full details of headlap and rafter lengths suitable for hook fixing, please refer to table 2 on page 4.

## Fixing method

Ensure each slate is centre nailed with 2 No. 30mm x 2.65mm jagged copper nails and restrained at the bottom edge with a copper disc rivet (19mm x 2mm stem, 19mm dia. x 0.5mm thick base). Double or slate-and-a half slates must be fixed with 3 No. nails and 2 No. rivets (see fixing positions Fig.7, page 15).

Note: Slates may also be fixed using stainless steel hooks. Please contact the Technical Advisory Service for further information on this method.

## Technical Support

If you have any questions or difficulties with the installation of Marley Eternit fibre cement slates, please contact the Technical Advisory Service on 01283 722588.

# Nail and rivet fixing

## Installation procedure for laying and fixing slates

**1** Set out the roof battens by calculating the gauge using the formula on page 7. Allow for the eaves courses of slates to overhang the fascia or tilting fillet so that the tails align with the centre of the gutter (approx. 50mm). (Fig 1).

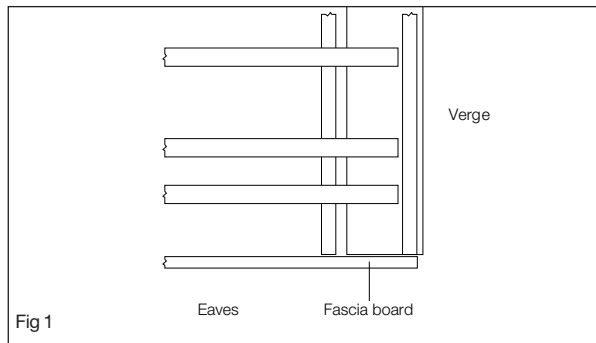

**2** Set out both under-eaves battens to accommodate the two lengths of under-eaves slates (Table 6 Page 21) allowing for correct lap and gauge. (Fig.2).

Cut the under-eaves slates from a standard slate and drill 2 no. 4mm dia. holes approximately 10-15mm in from the top cut edge and head nail the first under-eaves course along the eaves.

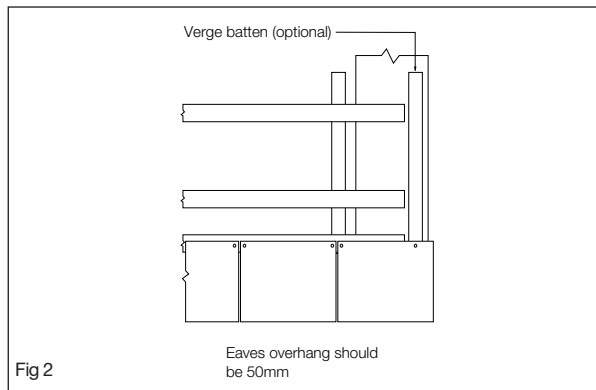

**3** Cut and nail fix second under-eaves course to the lower eaves batten with slate-and-a-half widths at the verge, ensuring a copper disc rivet is fitted centrally between adjacent slates (5mm gap) to align the pin with the hole in the front edge of the first course of full length slates.

Prior to fixing the slate-and-a-half verge slate, drill a 4mm dia. hole half a slate width distance in from the verge and 25mm up, to allow for the disc rivet to fix the first full slate course above.

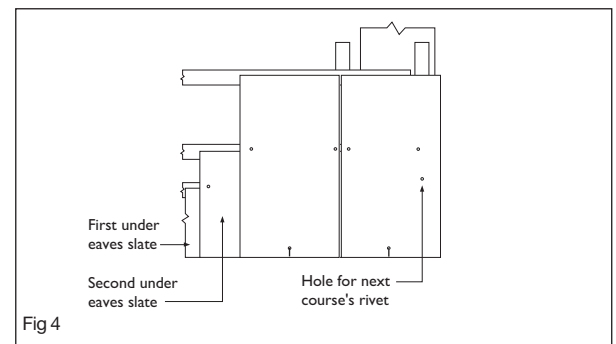
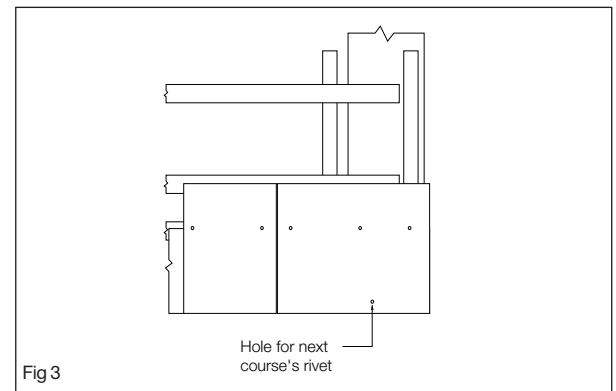

**4** At the verge, a second hole (4mm dia.) is required to allow for the copper disc rivet for the next course. This is drilled 50mm from the outside edge of the slate and 25mm plus gauge from the bottom edge, or tail.

# Nail and rivet fixing

Continue to lay the first course of full length slates, twice nailing each slate, and inserting a copper disc rivet between adjacent slates aligned with the hole in the front edge of the slate above (Fig 4).

When the next course of slates is laid above, the rivet shank is passed through the hole in the front edge of the slate and the rivet shank bent 90° so that it faces down the roof slope to secure the tail of the slate (Fig. 4). To achieve the correct bend in the rivet shank, it is best to tap it twice with a hammer, once at about 45° to the pin, and then finally onto the surface of the slate (Figs 5 & 6).

At the verge, a second hole (4mm dia.) should be drilled 50mm distance from the outside edge of the slate, and 25mm plus the gauge distance from the tail, to allow the disc rivet pin to be inserted for the next course above.

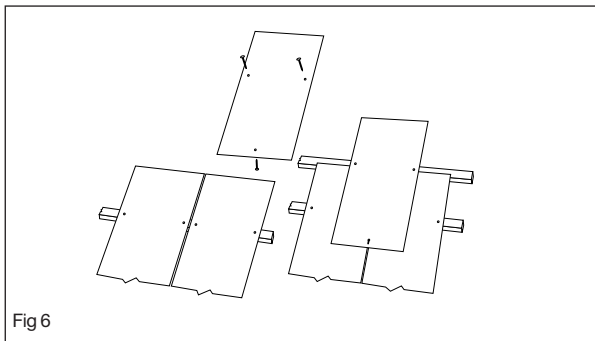
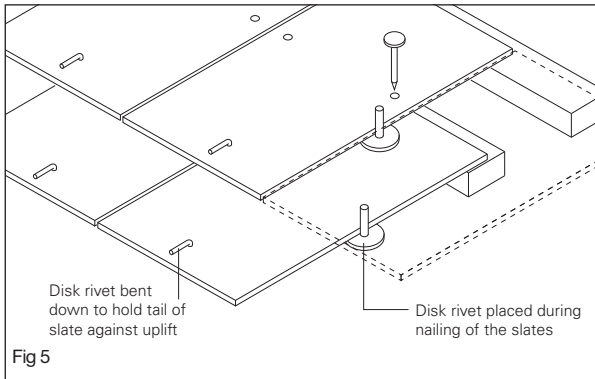

5 At verges and abutments, lay the first full length slate-and-a-half slate, ensuring that 3 No. 4mm dia. holes are drilled on the batten line with 2 No. additional holes for the copper disc rivets.

For remaining courses where single and slate-and-a-half slates are used, a third disc rivet hole is needed to allow for the rivet pin for the next single width verge slate (at point C). This is drilled half the single slate width from the side of the slate and 25mm plus the gauge distance from the tail (Fig 7).

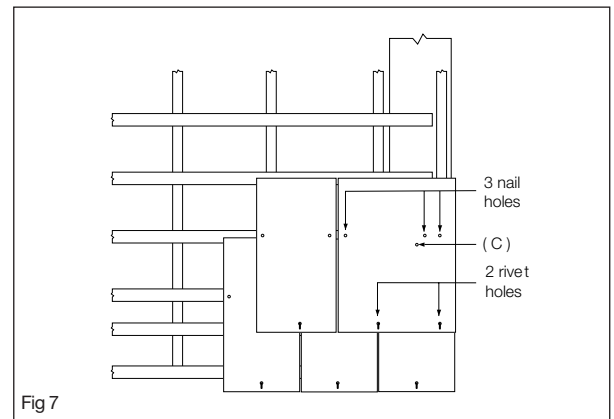

6 Continue diagonally up the roof with standard size slates, trimming to verges, hips, valleys and ridges as required. Slate-and-a-half widths should be used (Fig 8) if the half slate is less than 150mm wide.

At valleys and hips where slates need to be cut on the rake, wide slates must be used to maintain an adequate width and sidelap at the head or tail. At mitred hips on low pitched roofs wide slates should be used beneath the hip capping.

# Nail and rivet fixing

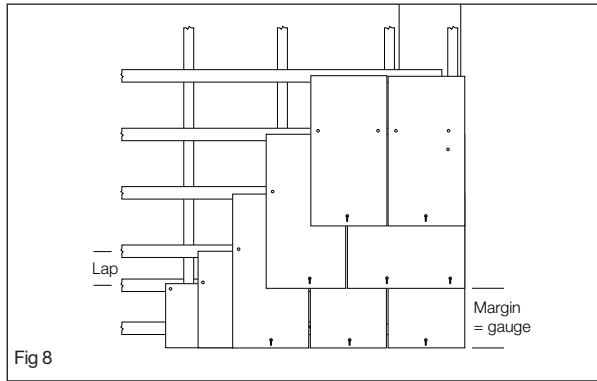

7 At the roof apex or top abutment, an additional top course batten is fitted directly above the last full length slate batten. The last full length roof slates/short courses are cut to length so that their top edges rest on the lower batten and are centre nailed as normal.

The top course slates should be cut to length and head nailed as per the under-eaves course slates with a disc rivet fitted to the tail (Fig 9).

Note: To ensure the top course slates lay neatly, a thicker batten can be used to compensate for the thickness of the slate course below.

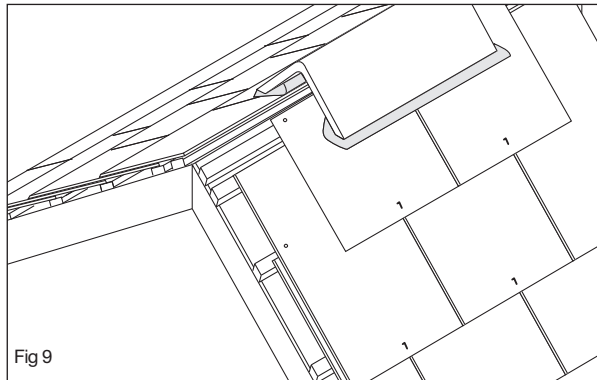

# Hook fixing method

(for Birkdale slates at 15°)

## Introduction

- All slates should be fixed in accordance with BS 5534 and BS 8000-6
- Slates should be laid broken bond using slate-and-a-half width slates in alternate courses formed from double width slates at verges, hips, valleys and abutments.
- Allow a 5mm gap between adjacent slates for disc rivet shank
- Nail slates firmly but do not drive nails too tight to the surface of the slate
- For full details of headlap and rafter lengths suitable for hook fixing, please refer to table 2 on page 4.

## Fixing method

Birkdale slates for low pitch are fixed with stainless steel hooks. 1st and 2nd eaves course, verges, trimming to verges, hips, valleys and ridge will require the use of copper nail (30mm x 2.65mm) and copper rivet (19mm x 2mm stem with base 0.5mm thick).

## Technical Support

If you have any questions or difficulties with the installation of Marley Eternit fibre cement slates, please contact the Technical Advisory Service on 01283 722588.

# Hook fixing method

(for Birkdale slates at 15°)

## Installation procedure for laying and fixing slates

**1** Set out roof with battens gauged to suit a 225mm long first under-eave course, a 375mm long second under-eave course and general batten gauge of 225mm (Fig 10). Allow a 50mm eave overhang into gutter.

Begin by cutting to size and drilling 2 no. 4mm holes 20mm in from either edge of the slate for head nailing the first under-eaves course along the eaves. (Fig 11)

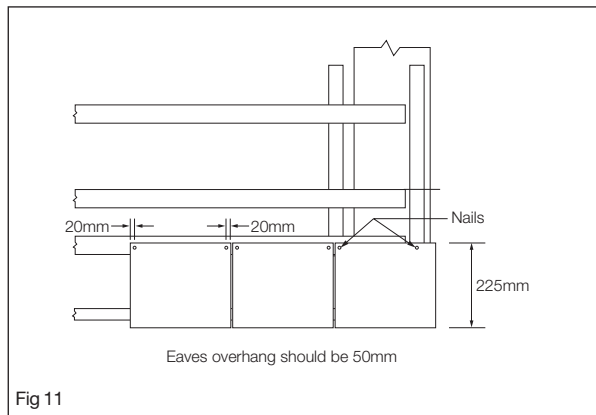
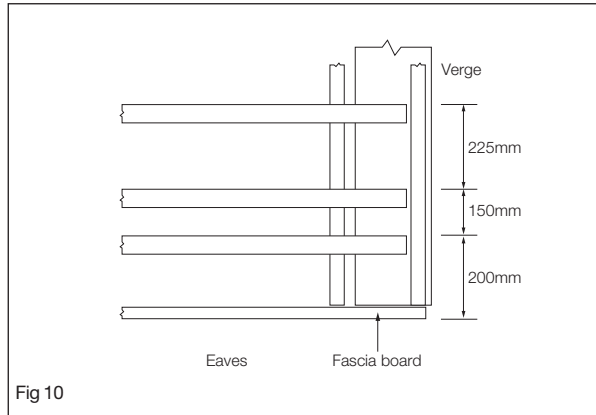

**2** Cut to size and drill 2 no. 4mm holes 20mm in from either edge for shoulder nailing the second under-eaves course of full width slates to the bottom batten. The slate-and-a-half widths laid at the verge require 2 additional drilled holes, 1 on the batten line for centre nailing and 1 drilled half a slate width in from verge and 25mm up, to allow for a copper disc rivet to fix the first full slate course. (Fig 12)

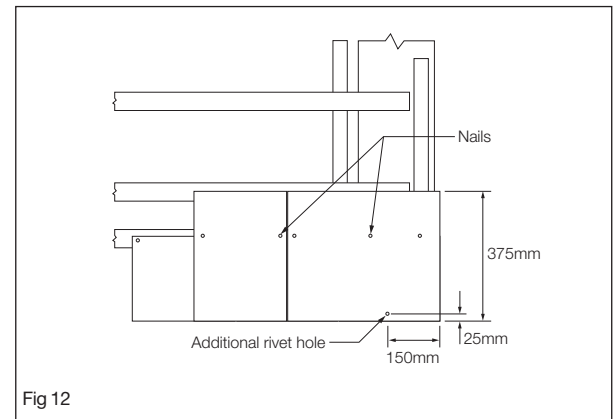

→ More

web: see our installation video at  
[www.marleyeternit.co.uk/birkdale](http://www.marleyeternit.co.uk/birkdale)

# Hook fixing method

(for Birkdale slates at 15°)

**3** Fix the first course of full size slates. All these slates need to be drilled with 3 no. 4mm holes, 2 for shoulder nailing to the batten 20mm in from each edge and 1 drilled along the centre line of the slate and 25mm up from the bottom edge to accept a copper disc rivet fitted between the perps of the course below. At the verge, a fourth 4mm hole is required to allow for the copper disc rivet for the next course. This is drilled 50mm from the outside edge of the slate, and 25mm plus gauge (225mm) from the bottom edge. (Fig 13).

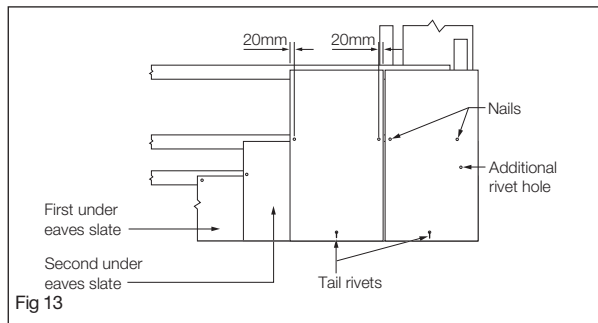

**4** At the verge on the course above install the first full length slate-and-a-half slate, by drilling 3 no. 4mm nail holes on the batten line for shoulder nailing and two additional 4mm holes for the copper disc rivets to secure the tail of the slate and that of the slate above (Fig 14).

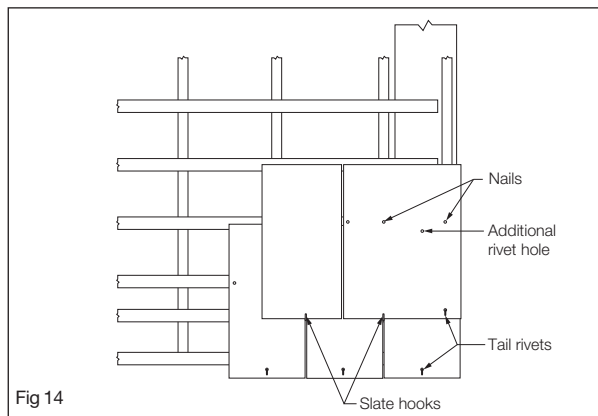

**5** Each full size slate on this course is now fixed with a 150mm long spiked hook driven into the batten between the edges of the two slates below. (Fig 15)

The full size slate fitted at the verge on the course above requires 2 no. 4mm nail holes drilled on the batten line as well as 2 no. 4mm disc rivet holes to accommodate the tail rivet for the slate and half slate above. (Fig 16).

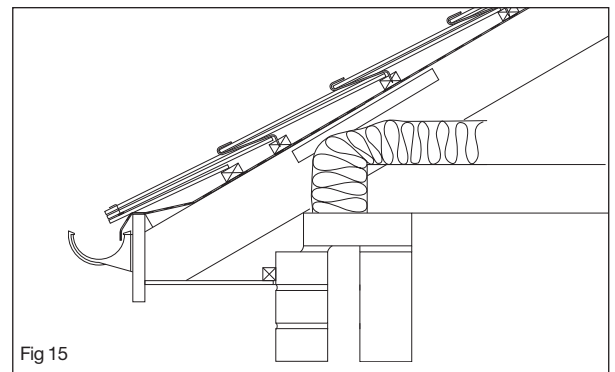

**6** Continue across and up the roof with hook fixed whole slates and nail and riveted verge slates, trimming to verges, hips, valley and ridge as necessary.

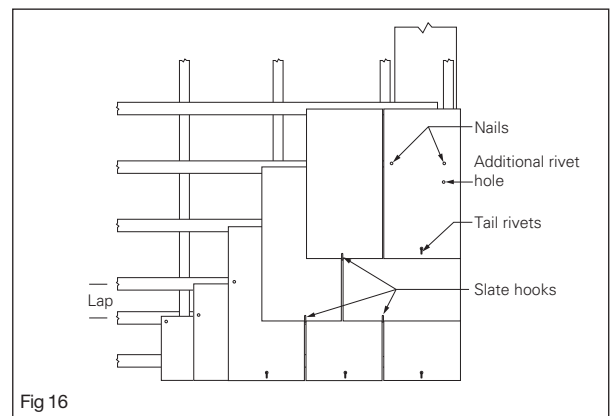

# UNIVERSAL

## 10 & 25mm eaves vent

Ventilation requirements to be in accordance with BS 5534 and BS 5250. A tilting fillet is required when using the eaves ventilator. The tilt is formed by raising the fascia board 11-18mm above rafter level. The eaves vent unit is placed on the fascia providing the required tilt, removing the need for an eaves underlay protector.

Marley Eternit universal eaves ventilation systems are designed to provide continuous 10mm or 25mm free vent areas to roof voids in an efficient and unobtrusive manner for roof pitches to 55°. The 25mm system can also be used to ventilate the batten cavity where this is required.

### Rafter roll

The continuous rafter roll provides a clear airpath over the insulation irrespective of soffit width and roof pitch by preventing the insulation blocking the eaves ventilator.

It will accommodate rafter centres from 400mm to 600mm whilst still providing the correct nett free area.

### Fixing

- 1 Locate and nail one end of the rafter roll over the rafter.
- 2 The formation will fit directly onto the rafters at 400mm and 600mm centres.
- 3 By pulling to extend the length of the panel it may also be attached to rafters at 450mm centres.
- 4 Subsequent panels should overlap on the rafter fixing.
- 5 Fix the eaves ventilator onto the rafters with 4 No. 30mm x 8 swg galvanised woodscrews.
- 6 Lay the underlay over the ventilator, stopping short of the mesh so that air flows through the mesh.
- 7 Fix the eaves batten so as to allow the underlay to oversail the eaves ventilator unit and not trap water behind the unit.

Note: The eaves ventilator cannot be used with hook fixing systems unless the eaves course is nailed.

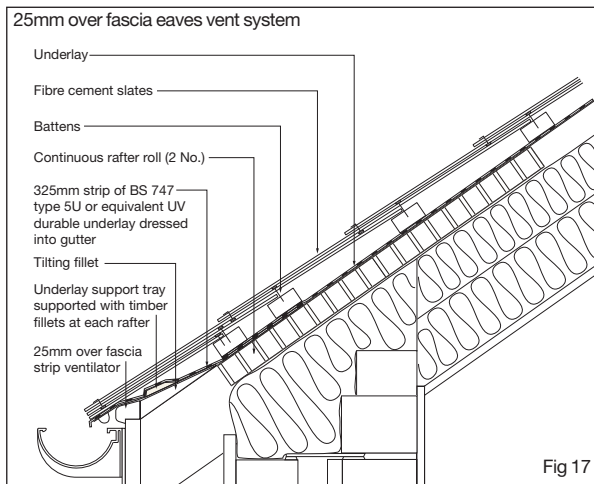

Fig 17

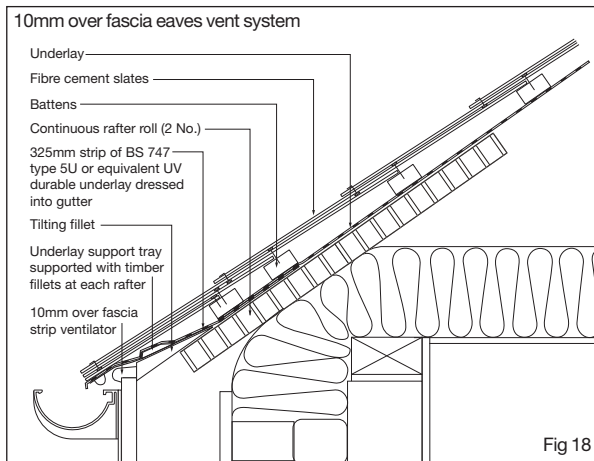

Fig 18

Table 6

Main roof pitch	fascia reduction	Main roof pitch	fascia reduction
15°	4mm	35°	16mm
20°	7mm	40°	19mm
25°	10mm	45°	22mm
30°	13mm	50°	25mm
		55°	28mm

### ➔ More

literature: Dry fix and ventilation systems including **UNIVERSAL**

tel: 01283 722588

web: [marleyeternit.co.uk/downloads](http://marleyeternit.co.uk/downloads)

[marleyeternit.co.uk/universal/productselector](http://marleyeternit.co.uk/universal/productselector)

# Standard eaves

## Eaves batten

Size as slating batten.

## Tilting fillet

The dual purpose of the tilting fillet is to ensure that the underlay is evenly dressed over the fascia to avoid trapping water and, in association with the fascia, commence the correct laying of the slates. To achieve these functions, the fascia/tilting fillet should be approximately 8-15mm above the top of the general batten level.

Note: at low pitches, the tilting fillet upslope length should ensure a minimum of 10° slope to the underlay.

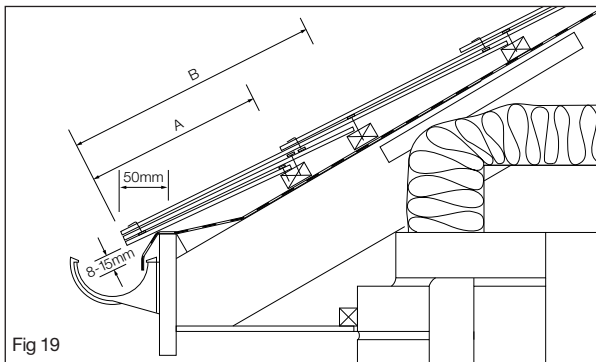

## Fixing

- 1 Install the underlay parallel to the eaves with the horizontal overlap appropriate to the rafter-pitch (see page 6).
- 2 Ensure that the underlay overhangs the fascia sufficiently to drain into the gutter and that dressing the underlay over the tilting fillet prevents any collection of water.
- 3 Locate and secure the battens to the correct centres appropriate to the size of slate.
- 4 Follow the slate fixing procedure described on pages 22 to 25.
- 5 Place rivets between the slates on the second under-eaves course, head resting on the lower slate course. Pass the rivet shank through the hole provided in the first full length slate at its tail. Secure slate and dress the rivet shank down the slope.
- 6 Proceed laying further full length slates up the roof.

# Standard eaves

For fibre cement slates, it is essential for the function and long term performance of the roof that three courses of slates are laid at all eaves. Set out the under-eaves battens to accommodate the typical under-eaves slate lengths as shown in Table 7 below.

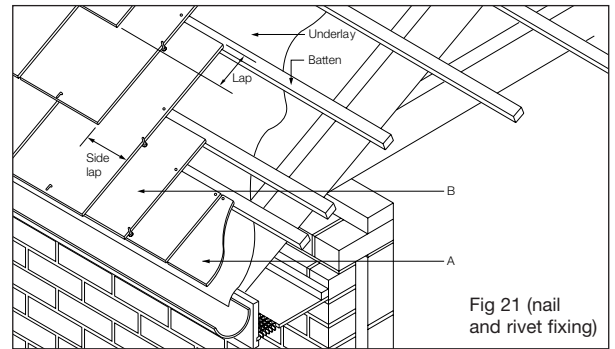
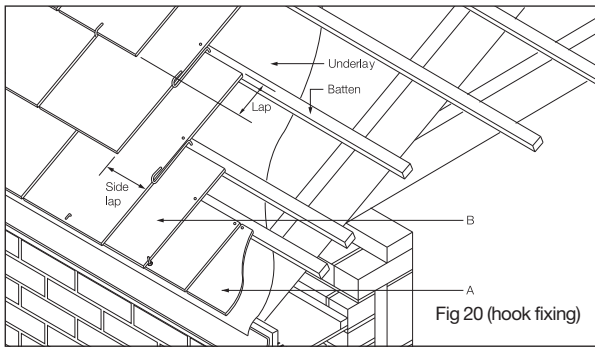

Table 7: Under-eaves slate lengths

	Slate size (mm)	Typical Laps (mm)	1st under-eaves slate length (A) (mm)	2nd under-eaves slate length (B) (mm)
Birkdale (15-20°) hook fixed	600 x 300	150	225	375
Birkdale (20-90°)	600 x 300	110	245	355
Thrutone (15-90°)	600 x 300	110	245	355
Rivendale (20-90°)	600 x 300	110	245	355
Garsdale (20-90°)	600 x 300	110	245	355

## Slate verge trim

The aluminium slate verge trim provides the benefits of a dry verge for Marley Eternit fibre cement slates.

The trim can be used with or without bargeboard but is not suitable for raking verges.

### Installation for standard verge (bargeboards and brickwork)

- 1 Underlay and battens should be laid and cut flush with outer edge of gable wall or bargeboard.
- 2 Position the verge trim on top of the battens and align the vertical leg against the batten ends
- 3 Position the first length to overhang at the eaves into the gutter, by the required amount, and remove part of the down leg to allow fitting of the gutter.
- 4 Nail the horizontal flange of the trim to each batten using a 25mm long galvanised clout nail ensuring the batten ends are nailed to the substructure.
- 5 When joining adjacent lengths of verge trim, ensure the lower length of trim is nailed securely to each batten (joints at the centre of a batten).
- 6 Cut away a rectangle 15mm in from the end of the trim beneath the drip bead.
- 7 Trim the inside corner of the trim. Make a small triangular cut into the top lap of the trim and press down slightly. This will allow the upper length to push inside the lower length.
- 8 Ensure the two down-legs line up. Firmly push into place and nail into position.

**If the upper leg is to form part of a ridge joint, carry out the apex cutting process prior to nailing to battens.**

- 9 Slide the verge slates under the lip of the verge. Trim and nail in accordance with the recommended fixing specification.

**Please note that sheet metal cutters should always be used to cut the trim. Use protective gloves when handling to avoid injury from sharp edges.**

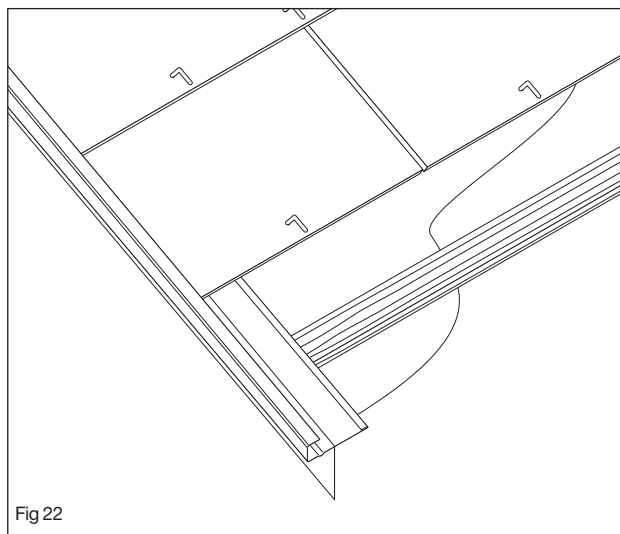

## UNIVERSAL

### Ventilated Ridge Roll for use with fibre cement ridges

The Marley Eternit duo pitch ventilated ridge system is manufactured in fibre cement for use with fibre cement slates. The fibre cement ridge cappings are used in conjunction with the ventilated Ridge Roll and provides 5000mm<sup>2</sup>/m ventilation to the roof apex.

#### Fixing

- 1 Lay the underlay along the ridge apex of the roof ensuring a 5mm clear air gap is maintained between the top edges.
- 2 Fix the top course slate batten to suit the gauge of the slate size being used and fix an additional ridge fix batten downslope to enable the 60mm x 6.3mm self-sealing wood screw fixings to penetrate the ridge unit 50mm from its bottom edge. (Certain constructions may require a longer screw fixing. In such cases, consult the Technical Advisory Service)
- 3 Head nail the top course slates to the top battens either side of the ridge apex, ensuring a 5mm clear gap is maintained between the top edges.
- 4 Unroll a 6 metre length of Fibre Cement Slate Ridge Roll (sold separately) centrally along the length of the ridge apex. (At gable ends the roll should overlap the gable end by approximately 50mm or in the case of a mortar bedded verge cut back 50mm from the gable.)
- 5 Remove the release paper covering the mastic strip on the underside of the corrugations on both sides of the roll and press the corrugations onto the top course slates either side of the ridge line.
 

**Important: Ensure the area of slates onto which the mastic strips will be adhering is thoroughly dry and dust free.**
- 6 Repeat this process along the entire length of ridge, overlapping the roll ends by 100mm at each joint.
- 7 Locate the starter ridge stop end at one end of the roof apex, above the Ridge Roll, and drill and screw the end of the ridge to the ridge fix battens. Holes should be drilled 125mm from the effective ends, 50mm up i.e. ignoring the socket.
- 8 Apply a 6mm dia. butyl strip across the socket, 50mm from the end.
- 9 Locate successive ridge units above the Ridge Roll along the ridge, drill and screw to the ridge fix battens, ensuring a level ridge with joints bedded onto the butyl strip.
- 10 Shorten the ridge units and finish the stop end as necessary, including the removal of the socket. Avoid using ridge units less than 450mm long and do not shorten the stop ends.

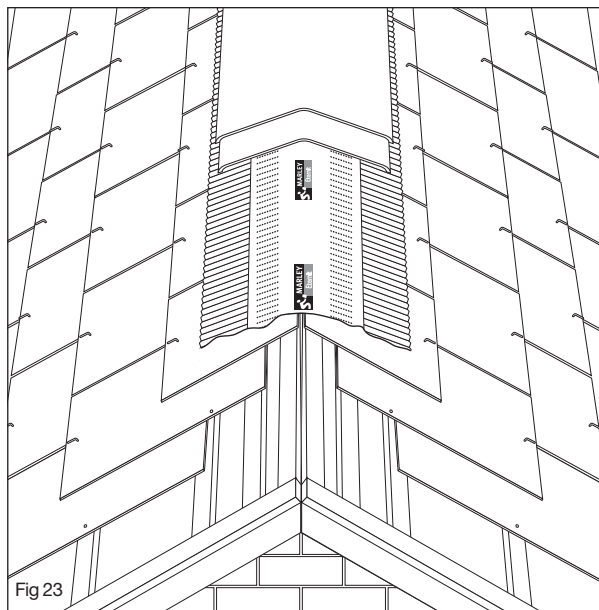

# Dry ridge system with concrete ridges



## Fixing

- 1 Lay slates up to dry ridge batten so back edge of top full length slate engages into batten section.
- 2 Centre nail to top batten in normal way.
- 3 Where a full length slate-and-a-half abuts the verge, cut a 3mm wide slot parallel to the verge from the head of the slate down to the point where the leading edge of the top course slate will be. This slot should be a half slate width in from the verge to allow for hook fixing the standard width slate above.

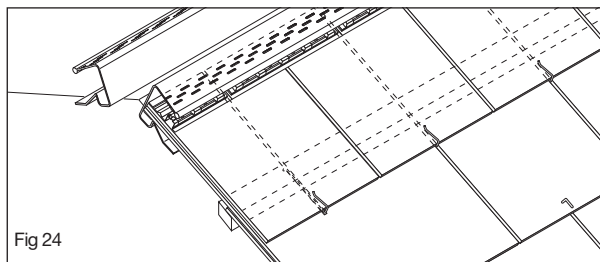

- 4 Drive appropriate size slate hook into top timber batten between each full length slate.
- 5 Slide top course slates (cut to length) into place so leading edges are retained centrally by slate hooks.
- 6 Back edge of top course slates should touch inside edge of ridge batten section.
- 7 Place ridge filler units in position, trapped between top slate and top edge of batten section, butted together along length of ridge.
- 8 For mortar bedded verges, hips and valleys drill a 4mm diameter hole through top two courses as shown opposite 25mm from verge and insert a copper slate nail.

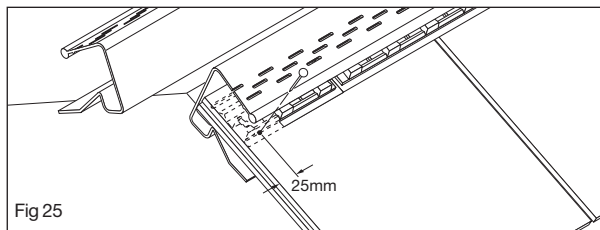

- 9 Ridge filler unit should cover nail head, preventing internal movement of top course slate.

# Fibre cement duopitch ridges (unventilated)

Fibre cement duopitch ridge units and stop ends are designed with a socket for a simple fix by drilling and screwing to an additional ridge fix batten at the apex. Recommended screws are 60mm x 6.3mm self-sealing wood screws. Other sizes are used for different applications – contact the Technical Advisory Service. An alkali resisting, non-oil based 6mm diameter butyl strip should be used to seal across the socket, 50mm from the end.

## Fixing

- 1 Fix the underlay along the roof apex to overlap opposite roof slopes by 300mm.
- 2 Fix the top batten to suit the gauge of the slate.
- 3 Fix an additional ridge fix batten downslope to enable the self-sealing screw to penetrate the ridge unit 50mm up from the bottom edge of the ridge unit.
- 4 Head nail the top slate course to the top batten. Locate the starter ridge stop end at one end, drill and screw the end of the ridge to the ridge fix battens. Drill 125mm from the effective ends 50mm up, i.e. ignore the socket.
- 5 Apply 6mm butyl diameter strip across the socket, 50mm from the end.
- 6 Locate successive ridge units along the roof apex, drill and screw to the ridge fix battens, ensuring a level ridge with joints bedded on butyl strip .
- 7 Shorten the ridge units and finish the stop end as necessary, which may include removal of the socket. Avoid ridge units less than 450mm length. Do not shorten the stop ends.

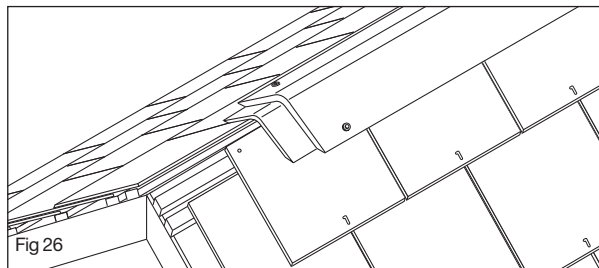

# Fibre cement mono pitch ridges\* (unventilated)

Fibre cement mono-pitch ridge units and stop ends are designed with an internal socket for simple fixing by drilling and screwing to battens, using 60mm x 6.3mm self-sealing woodscrews.

An alkali-resistant, non-oil based 6mm diameter butyl strip should be used to seal adjacent units at the sockets.

## Fixing

- 1 Extend the underlay over the apex of the roof.
- 2 Fix the top batten to suit the top course. Do not exceed the batten gauge.
- 3 Fix an additional ridge fix batten to enable the self-sealing screw to penetrate the ridge unit 50mm up from the bottom edge, as illustrated below.
- 4 Head nail slates into the top batten.
- 5 Locate the ridge stop end, drill through the ridge and top slates, 125mm from the effective ends of the ridge and 50mm up from the bottom edge.
- 6 Apply a 6mm diameter butyl strip across the socket 50mm from the end.
- 7 Locate successive ridge units along the ridge, drill and screw as before, ensuring a level ridge.
- 8 Shorten the ridge units and finish the stop end as necessary, which may include the removal of the socket. Avoid using pieces less than 450mm long. Do not shorten the stop ends.

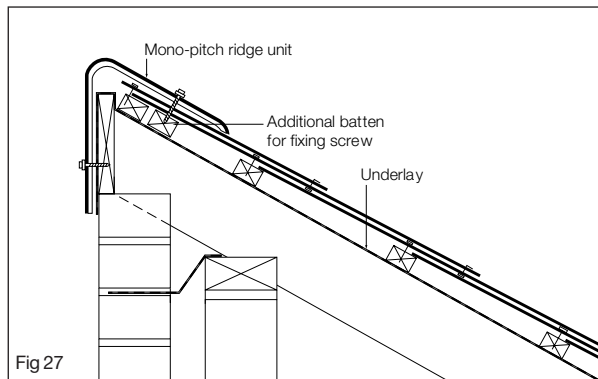

# Fibre cement duo pitch ridge vent terminal

The fibre cement in-line ridge vent terminal offers a practical and unobtrusive solution to the problem of roofspace ventilation and can also be used for terminating soil vent pipes and mechanical ventilation systems when used with the stepped pipe adaptor. It provides 10,000mm<sup>2</sup> free vent area .

## Fixing

- 1 Suitable for roof pitches 20-45° (use appropriate duo pitch fibre cement in-line ridge ventilator).
- 2 Locate between two adjacent rafters and at least 600mm from any flue outlet.
- 3 Cut underlay around riser and fold up to protect from water ingress.
- 4 Provide additional battens for fixing ridge vent.
- 5 Fix shorter top course slates and standard slates to battens in normal manner.
- 6 Fit ridge vent capping and drill and screw fix to ridge battens using 60mm x 6.3mm self sealing wood screws.
- 7 Bed ridge vent capping joints with butyl strip.
- 8 Push fit stepped pipe adaptor as required.
- 9 Ensure all ductwork is fully supported.

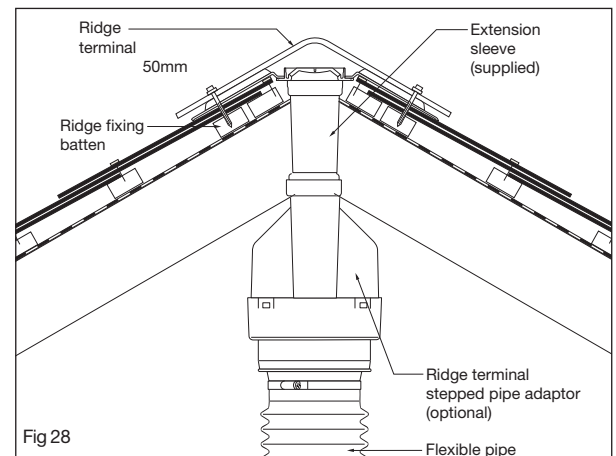

## UNIVERSAL

HipFast for use with fibre cement slates, concrete and clay ridges

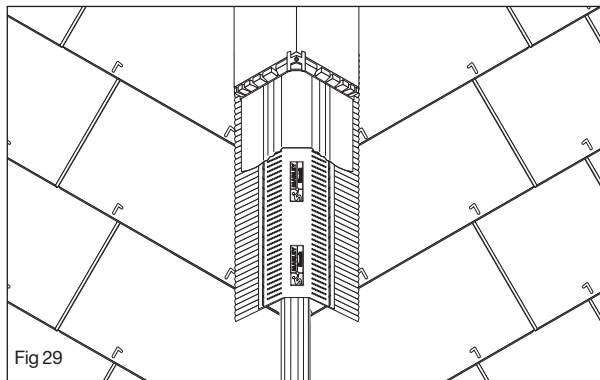

HipFast is a simple and rapidly installed, dry fixed hip system suited to all Marley Eternit tiles and slates, as well as those of other manufacturers.

### Fixing

- 1 Lay roof underlay and battens in the normal manner, leaving a 5mm continuous gap in underlay either side of hip rafter if roof void is to be ventilated. Mitre cut the ends of tiling battens and support on hip rafter.

If rigid sarking is used, finish the board at side of hip rafter.

- 2 Slate roof leaving a gap of 80mm between raking cut slates laid adjacent to hip rafter.
- 3 Ensure that all raking cut roof slates along the length of hip are secured using the head 'C' clips and tail clips provided.

In areas of high exposure, raking cut slates may be bonded to adjacent fully fixed slates using an appropriate epoxy resin adhesive. This will minimise the risk of smaller cut pieces of tile or slate becoming dislodged. (Details of suitable adhesives can be obtained from the Technical Advisory Service).

- 4 Fix Hip Batten Brackets to hip rafter using nails provided (4 No. per bracket) at approx. 550mm centres.

Ensure first Bracket is fixed as close as possible to base of the hip rafter and top most Bracket no more than 100mm from hip/ridge apex, trimming back from hip rafter, locally, to provide space for fitting hip brackets.

Support any batten ends with noggins.

Batten Brackets can be fitted at a choice of two heights achieved by bending bracket legs inwards along the appropriate diagonal line of holes.

- 5 Secure either one or two thicknesses of 50mm x 25mm tiling batten to the top of Batten Brackets, parallel to hip rafter, by folding over Batten Bracket arms and nailing through perforations into the battens.

Where two battens are needed, ensure lowest is screwed to upper batten before locating into Batten Brackets, with any joints in hip battens made over Batten Brackets to ensure both ends are fixed.

*Note:* To establish if one or two batten thicknesses are required, place a hip tile over the hip junction at the highest point of the tiling and assess the space remaining between the top of the batten bracket and the underside of the hip tile. Install two battens where two battens locate without fouling the hip tile.

- 6 Starting from eaves, roll out HipFast roll centrally over hip rafter battens, and secure in position using well spaced felt nails, leaving a distance of 100mm to oversail the hip/ridge apex. Joints along hip should be lapped by 100mm to drain water down roof.
- 7 Remove backing tape. Press adhesive strips on both sides of hip firmly onto tiles. Both sides should be dressed down together to ensure edge of roll is kept aligned.
- 9 Cut a HipFast Hip Support Tray to suit angle and overhang of tiles at eaves, and fix centrally over hip rafter battens.

Wash off any surface dust on the raking cut tiles with a brush and water and allow to dry thoroughly prior to sticking down the HipFast Roll.

Continue to nail HipFast Support Trays up hip, ensuring a 50mm lap over top of tray already fixed. Where two hips meet at ridge mitre each tray at internal angle.

### Continues overleaf

# UNIVERSAL

## HipFast (continued)

- 10 Fit a purpose designed Block End Hip tile tight against eaves tiles and trim the Block End if required. Fix Block End Hip tile through HipFast Hip Support Tray to hip batten using 75mm x 4.8mm screw and sealing washer provided. Tighten securely to ensure a firm seal.
- 11 Select a hip union, union clamp and 75mm x 4.8mm screw. Fit a union clamp into the central slot in the hip union and offer up the assembly into the open end of the hip tile so that it is trapped between the clamp and the union flange. Where the ends on the union overlap the edges of the hip tile, cut off or fold inward the excess length along the crease lines at either end.

When the union clamp is fully engaged in the hip union, it may create an interference fit with the sub-structure. In this case, the protruding length of the clamp can be snapped off below the hip union flange.

- 12 Position next Hip tile into open side of Hip Union and Clamp assembly. Continue process of laying the Hip tiles, unions and clamps towards the apex, ensuring that tiles are aligned. Secure unions through Union Clamp to hip batten using the screws provided. Ensure screws are tightened well and the edges of the Hip tiles sit evenly on Hip Support Trays.

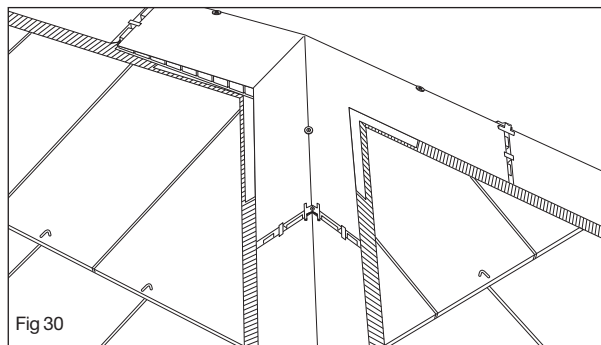

- 13 At apex, ensure final Hip tile is a full length unit, with any adjustments to suit the length of hip taken up by cutting the adjacent one or two Hip tiles.

Top Hip tile should be mitred into other Hip and Ridge tiles.

- 14 The HipFast Apex Flashing can be used as either a soaker or flashing. As a soaker, it is adhered directly to the HipRoll/RidgeRoll to weather the hip apex junction, and trimmed to suit. As a flashing, it is fitted over the apex slates and trimmed to the base of the slate edges.

To apply the Apex Flashing, peel off the release paper and drape over the HipRoll/RidgeRoll or hip/ridge mitred junction, pressing firmly into place. Trim excess material to suit using a sharp knife. (When the release paper has been removed, take care to avoid the mastic sticking to itself).

Ensure the tiles to be covered are both thoroughly dry and dust free before fitting.

- 15 Secure the mitred end of the top Hip tile by drilling a 6mm dia. hole centrally through the tile, approx. 125mm down from the apex, using a masonry drill. Fix the Hip tile to the hip battens using a screw with washer provided.

Note: When using the Marley Eternit Universal HipFast system with the Marley Eternit Universal RidgeFast system, the mitred end of the Ridge tile should be secured to the ridge batten by drilling and screwing in the manner described above.

When using the Marley Eternit Universal HipFast system with alternative ridges, valley and abutment details, a Code 4 lead saddle may be used to weather the junction.

- 16 Where Marley Eternit RidgeFast is also being used and the hip tiles are the same as the ridge tiles, a Tapered Filler unit must be fitted beneath both edges of the end ridge tile to ensure a close fitting mitre can be achieved at the apex.

The Fillers are trapped between the RidgeRoll and the bottom edges of the ridge tile, with the deeper end toward the hip. With profiled tiles, a 500mm length of HipFast Support Tray must be nailed centrally to the ridge batten through the RidgeRoll to act as a bearer for the Tapered Fillers and end ridge tile.

# Close mitred hips

Close mitred hip constructions are not generally recommended for pitches of below 30°. If the site is in an exposed location, additional fixings are required.

## Fixing

- 1 Dress the underlay along each slope and cut at the hip rafter. Dress additional underlay along the hip rafter, overlapping 300mm on each side.
- 2 Fix roofing battens to the hip rafter and align on each slope. Insert lead soakers in every course up the hip.

Mitred slates cut from double blank units must be fixed with three copper nails and two copper disc rivets. The third nail must be fixed into either:

- A** An additional batten parallel and central to the slating battens securely fixed to at least two rafters on either side of the hip.
- B** A continuous board either side of the hip, again securely fixed, or
- C** A continuous batten either side.

In areas of severe exposure, a supplementary fixing in addition to the above should be used. Refer to Technical Advisory Service for further advice.

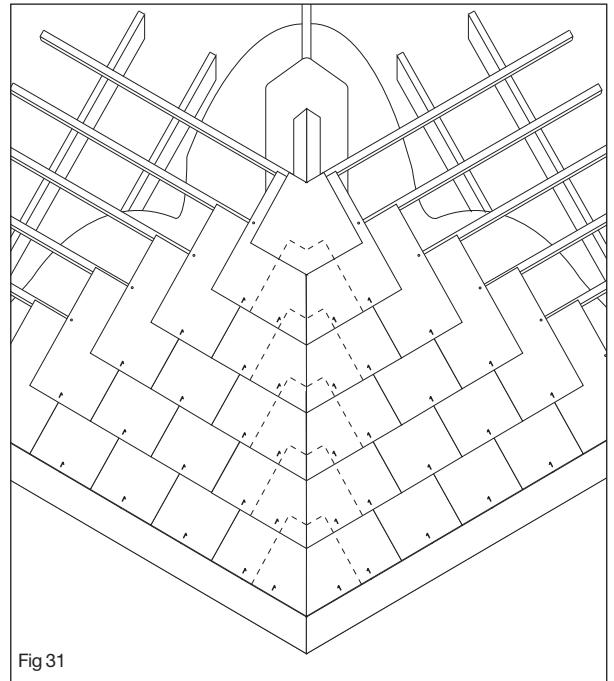

Fig 31

## UNIVERSAL GRP valley



Developed to allow the designer freedom to specify a completely mortar-free roof, this system utilises the latest GRP technology. The advanced and unique parabolic gutter section improves discharge rates without added gutter depth.

### Fixing

- 1 The valley trough may be fixed directly onto counter battens either to existing or new valley boards.
- 2 The valley should first be lined with an approved underlay one metre wide.
- 3 Counter battens of the same depth as the tiling battens should be nailed onto the valley boards over the underlay.
- 4 The lengths of the valley trough should be firmly pressed down on to the valley board to support the base and nailed, through pre-drilled holes at a maximum of 500mm centres, to the counter battens.
- 5 The roof tile underlay should then be laid and dressed over the counter battens.
- 6 The fascia board should be cut to allow the GRP valley trough to pass through and discharge into the gutter without flattening out. The end should be trimmed to the approximate centre line of the gutter.
- 7 At the head of the valley, a lead saddle should be fixed to lap over the valley trough.

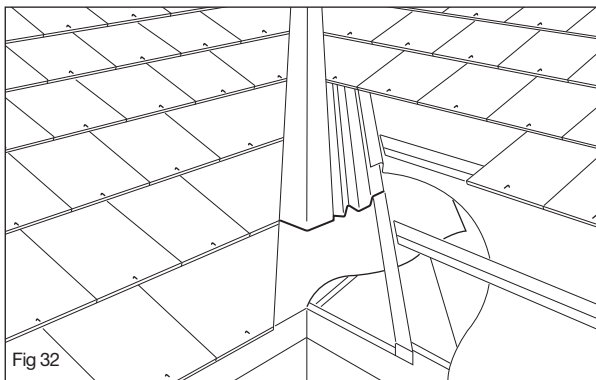

## Open metal valley

### Fixing

- 1 Fix support noggins to the inside of each rafter face at a level to receive individual lay boards between the rafters.
- 2 Nail valley boards to lay flush with the tops of the rafters, fix valley fillets ensuring sufficient valley width.
- 3 Drape the underlay and fix slating battens to bear 50mm on each valley board.
- 4 Lift the underlay and fix the lead gutter lining over the valley boards and dress on valley fillets. Form welted ends on the inside edges of the gutter lining, reposition the underlay over the welted edges of the valley and trim 40mm beyond the fillets.
- 5 Vertical infill noggins or raking battens maybe required between the slating battens to accommodate the third slate nail.

Note: If trussed rafters are used, the manufacturer may not permit the notching of rafters. This can be overcome by fixing timber noggins to the insides of the rafter faces at a level to receive individual lay boards between the rafters.

- 6 Centre-nail slates, positioning rivets before fixing down. Ensure a 50mm overhang from the valley fillet and provide the required clear gutter to maintain an uninterrupted flow of water from the roof

Note: Double width slates should be used in every course adjacent to the valley with additional nail fixings.

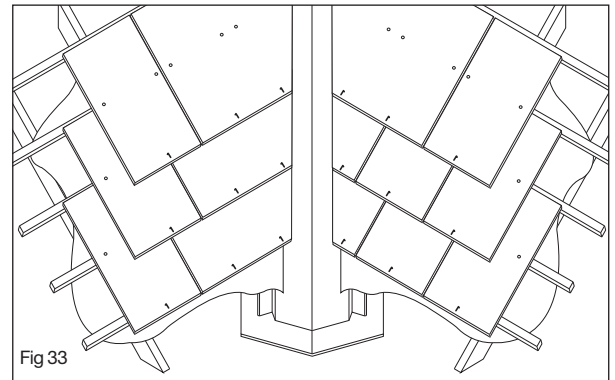

# abutments

## Top abutment ventilation system

### Fixing

- 1 Felt and batten roof in normal way but do not return felt up abutment wall.
- 2 A gap of 5mm to 10mm should be left to allow air flow from roof void.
- 3 Cut a small piece of lead support to use as a guide to setting out uPVC batten section. Lead support strip should coincide with a mortar joint above line of tiling and leave a gap not less than 5mm between batten section and wall ).
- 4 Lead support should not be in contact with top flange of batten section, otherwise ventilation flow will be affected.
- 5 Roof is slated in normal way and top course slates with their respective fillers fitted into batten section .
- 6 Ensure each top course slate is secured by a hook.  
  
Complete main roof slating in the normal manner. Refer to page 20 (Dry ridge system) for instructions for fitting top course slates and filler units into batten section
- 7 Clip lead support strips to batten section so that free edge rests in mortar joint previously identified.
- 8 A gap of about 5mm should be left between successive lengths of lead support to allow for thermal expansion.
- 9 Dress Code 4 lead or similar flashing material, over lead support strip and fit front edge into integrated retaining channel on front edge support.
- 10 Wedge hip edge of lead into mortar joint as required by the Lead Sheet Association.
- 11 Ensure laps are staggered to support the unit.
- 12 At verge, dress lead flashing down over verge, turn around corner of wall and secure in a mortar joint with lead wedges.

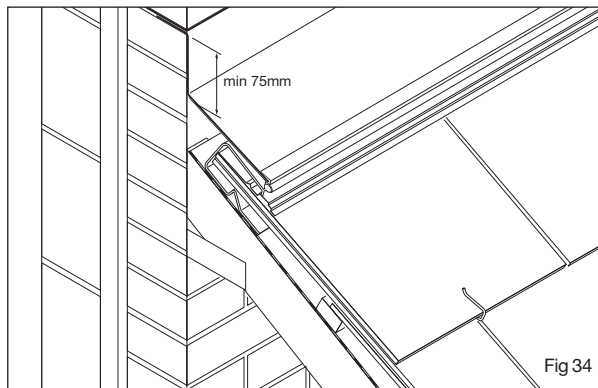

## Abutment with flashings

Where slates abut walls, chimney stacks, rooflights and dormer windows, etc, the jointing should be weathered by conventional lead soakers and flashings.

### Soakers (Code 3 lead)

Lengths should equal the gauge + lap + 30mm, to allow the flashing to be formed over the batten. Minimum width: 175mm. Soakers should be turned up to provide a minimum 75mm upstand and cover flashing to suit.

### Flashings (Code 4 or 5 lead)

Fix the flashings over the upstand of the soakers. The upper edge of the flashings should be turned into a groove in the walling, or the bed joint of the brickwork. Where the slates abut brickwork, a stepped flashing to accommodate the heights of the horizontal brick courses should be used.

Secure the flashings in the wall with wedges and point with cement mortar, in accordance with the requirements of the Lead Sheet Association.

Apply a coating of 'Patination Oil' to the surface and edges of the flashing immediately after the lead is fixed (see page 8).

# slate vent

## Fibre cement in-line slate vent terminal\*

Ideal for roof designs where the normal ventilation airpath is blocked by valleys, hips, abutments, dormer windows and firebreaks or party walls or where it is not possible to incorporate standard eaves or ridge ventilation. For use with fibre cement slates.

### Fixing

- 1 Felt and batten the roof in the normal manner.
- 2 Determine the position of the ventilator, between rafters. Cut the slate directly below the ventilator so that it does not project past the slate batten to which it is secured. Ensure that the bottom edge of slate vent aligns with bottom edge of adjacent slates. Remove a 280mm section of batten to accommodate the unit. Form a 'V' cut in the underlay in the manner shown to accommodate the rectangular spigot (Fig. 35).

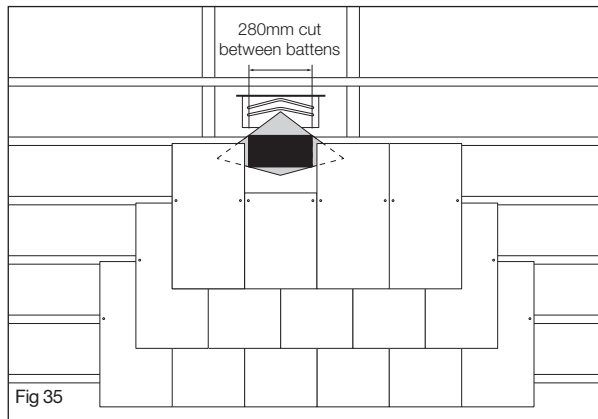

\*Minimum 20° roof pitch

- 3 Secure an additional support batten 20mm above the cut batten. Cut a 354mm horizontal slit in the underlay 50-60mm centrally above the additional support batten. Slide the underlay protector tray above the additional support batten until the protector's up-stand can be secured to the lower edge of this batten. Nail the uppermost 'V' of the underlay to the rear of the additional support batten (Fig. 36).

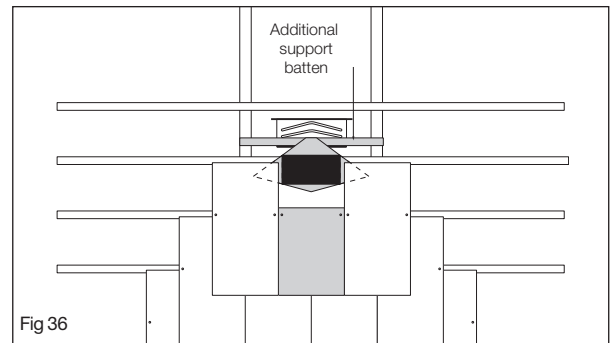

- 4 Position the Slate Ventilator centrally on the slate coursing below and level with adjacent slates. Drill two 5mm holes in the ventilator, ensuring adequate clearance to accommodate the copper disc rivet shanks for securing the tail of the overlapping slates (Fig. 37).

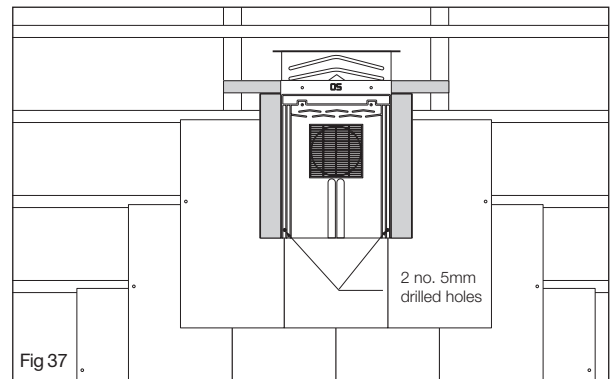

# Fibre cement slate vent terminal (continued)

- 5 Cut two 'C' shaped slates to fit either side of the ventilator so that they neatly abut the grille and central draining up-stand. Hole each formed slate piece as shown, ensuring that it is twice nailed to battens. Continue slating in the normal manner (Fig.38).

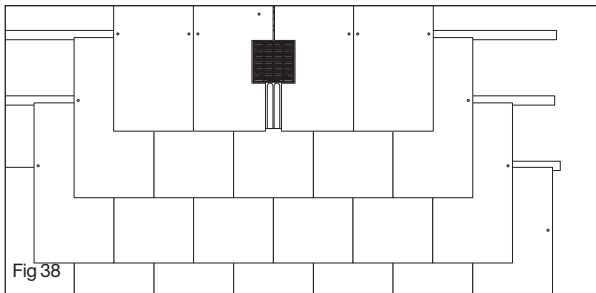

- 6 Lay the next course of slates, cutting the slate directly above, to neatly abut the ventilator grille as required (Fig. 39). Inspect the junction, security of the ventilating unit and adjacent slating before laying further courses. Continue slating in the normal manner (Fig.40).

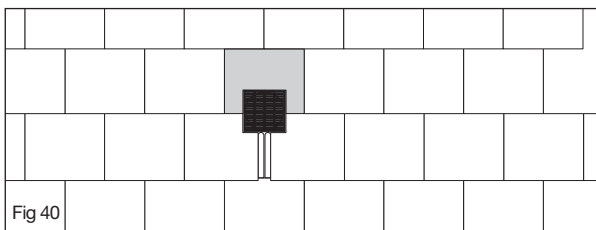
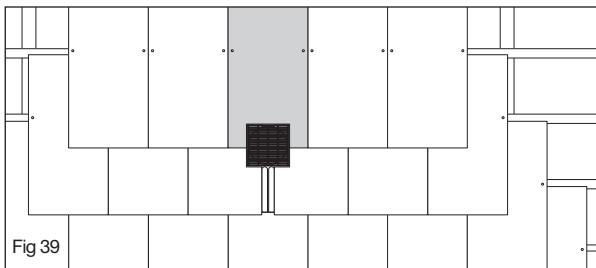

# Services

## Technical Advisory Service

Specifiers require prompt, knowledgeable and detailed responses to a vast range of enquiries covering everything from the embodied energy of a typical roof tile, to the different ventilation options available.



Our Technical Advisory Service is staffed by a qualified team with specialist knowledge not only of all Marley Eternit products, but also crucially, how those systems integrate with other roofing components and comply with Building Regulations, Health and Safety, environmental and other critical roofing criteria.

In addition to general technical enquiries, the services available from the Technical Advisory Service include:

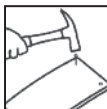

**Fixing specifications:** Bespoke fixing specifications can be provided, taking into account location, dimensions and degree of exposure for individual buildings.

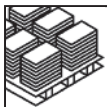

**Estimating the quantities:** Calculation of materials required for any roofing project including tiles, battens, underlay, ancillary fittings and accessories.

We also have on-line tools which can help create fixing specs or with estimating quantities.



contact tel 01283 722588  
e-mail info@marleyeternit.co.uk

## Customer Services

Marley Eternit is committed to providing outstanding customer care and is staffed by experienced personnel. Services include:



**Training Centre:** We have a purpose-built training centre where we are able to impart our expertise through a range of practical and classroom courses.

Tel 08705 626400

**Advice and ordering information**

contact tel 08705 626400  
e-mail info@marleyeternit.co.uk

**Literature:** All current product and technical literature can be downloaded from: [www.marleyeternit.co.uk/downloads](http://www.marleyeternit.co.uk/downloads)

contact tel 08705 626400  
e-mail info@marleyeternit.co.uk

**Stockist information:** To find details for stockists of Marley Eternit products, visit: [www.marleyeternit.co.uk/stockists](http://www.marleyeternit.co.uk/stockists)

contact tel 08705 626400  
e-mail info@marleyeternit.co.uk

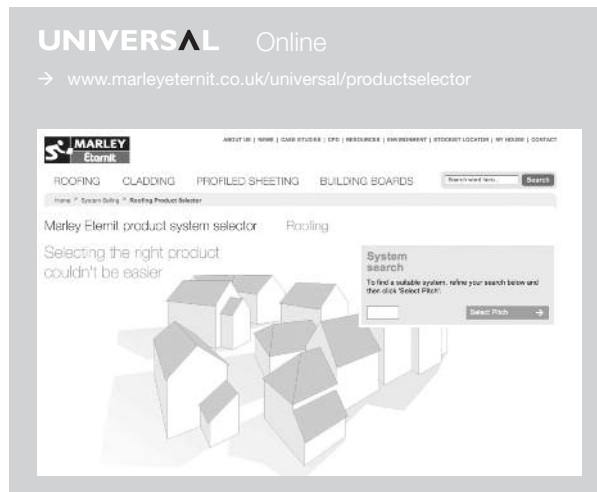

Call  
Email  
Or visit



on 01283 722588  
at [info@marleyeternit.co.uk](mailto:info@marleyeternit.co.uk)  
[www.marleyeternit.co.uk/slates](http://www.marleyeternit.co.uk/slates)



---

an **etex** company

Marley Eternit Limited, Lichfield Road,  
Branston, Burton on Trent DE14 3HD