



TECHNOLOGY IN MOTION

# MACO RAIL-SYSTEMS

SLIDING HARDWARE



## ASSEMBLY INSTRUCTIONS

HS COMFORT CLOSE / COMFORT STOP

concealed

Timber, Guide Track universal low

## Table of contents

<b>Important instructions</b>	<b>3</b>
<hr/>	
<b>Function</b>	<b>3</b>
<hr/>	
<b>Fittings overview</b>	<b>4</b>
<hr/>	
<b>Preparation frame - Example: scheme A and C</b>	<b>5</b>
<hr/>	
<b>Preparation sash</b>	<b>6</b>
<hr/>	
<b>Mounting Comfort Close/Comfort Stop</b>	<b>7</b>
<hr/>	
<b>Mounting sash and frame</b>	<b>8</b>
<hr/>	
<b>Reference dimension</b>	<b>9</b>
<hr/>	
<b>Completion of guide track</b>	<b>9</b>
<hr/>	
<b>Adjustment options</b>	<b>10</b>
<hr/>	
<b>Mounting cover frame piece</b>	<b>10</b>
<hr/>	
<b>Technical data</b>	<b>11</b>

## Important instructions

### Target group

This documentation is intended exclusively for specialist companies and certified specialists. The work described herein must only be carried out by certified specialists.

### Usage and safety information

In addition to this information, the profile-dependent assembly instructions for HS-Hardware System A, C, G, K Timber, Order No. 757077EN, must be complied with. In the Comfort Close assembly instructions, only the differences from the above document are described. Mount all hardware parts professionally as described in this manual and observe all safety instructions.

The HS Comfort Close may only be used in combination with gasket tracks – HS Set or Upper HS gasket track in PVC for slim cross-bars.

## Function

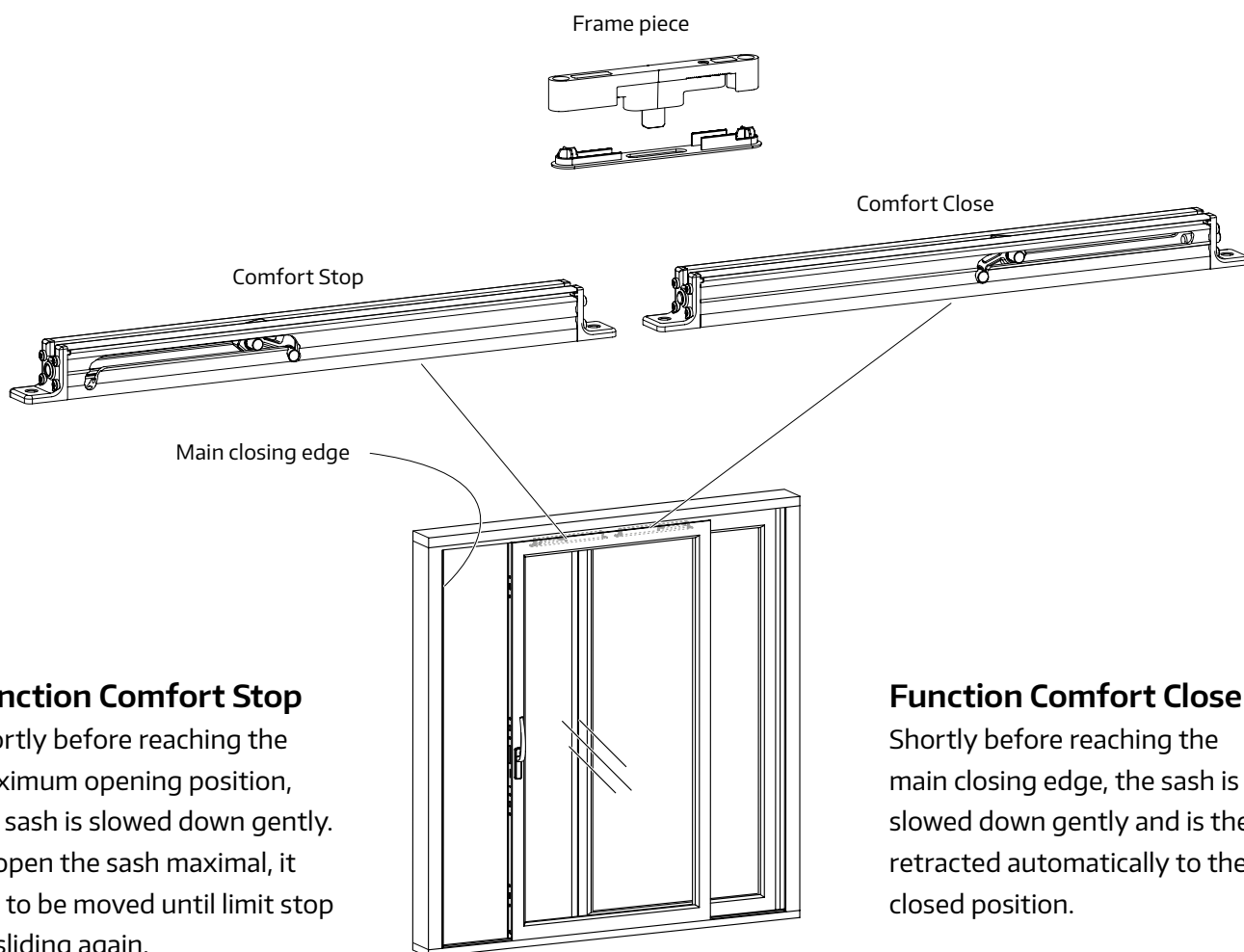

### Function Comfort Stop

Shortly before reaching the maximum opening position, the sash is slowed down gently. To open the sash maximal, it has to be moved until limit stop by sliding again.

### Function Comfort Close

Shortly before reaching the main closing edge, the sash is slowed down gently and is then retracted automatically to the closed position.

# Fittings overview

Pos.	Description
6.1	Guide Track
15.1	Comfort Close
15.2	Comfort Stop
16.2	Frame piece
16.3	Cover frame piece

**Note:** All measurements in this document are indicated in millimetres.

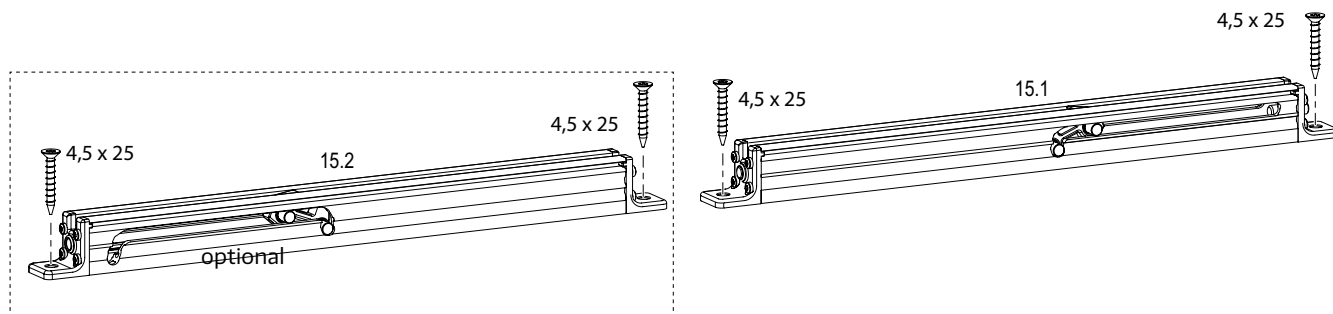
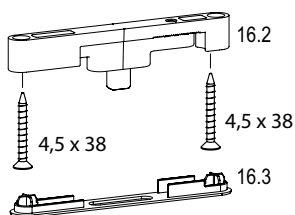

required for mounting:  
guide track

6.1



Guide track universal low

Screws are not included in scope of delivery. Respective specifications represent a recommendation, only.

## Items per sliding sash

		Article description	Item Code
1	Comfort Close 15.1 <sup>z)</sup>	size 1 ≤ 200 kg ≤ 30 N sash weight sliding force	300359
		size 2 > 200 ... 300 kg ≤ 50 N sash weight sliding force	300360
1 <sup>x)</sup>	Comfort Stop 15.2 <sup>z)</sup>	size 1 ≤ 200 kg ≤ 30 N sash weight sliding force	304052
		size 2 > 200 ... 300 kg ≤ 50 N sash weight sliding force	304053
1	Frame piece, adjustable 16.2		305134
1	Cover frame piece 16.3		304816

<sup>x)</sup> optional      <sup>z)</sup> Colour of damper: size 1 - black, size 2 - silver-grey

# Preparation frame - Example: scheme A and C

## Scheme A

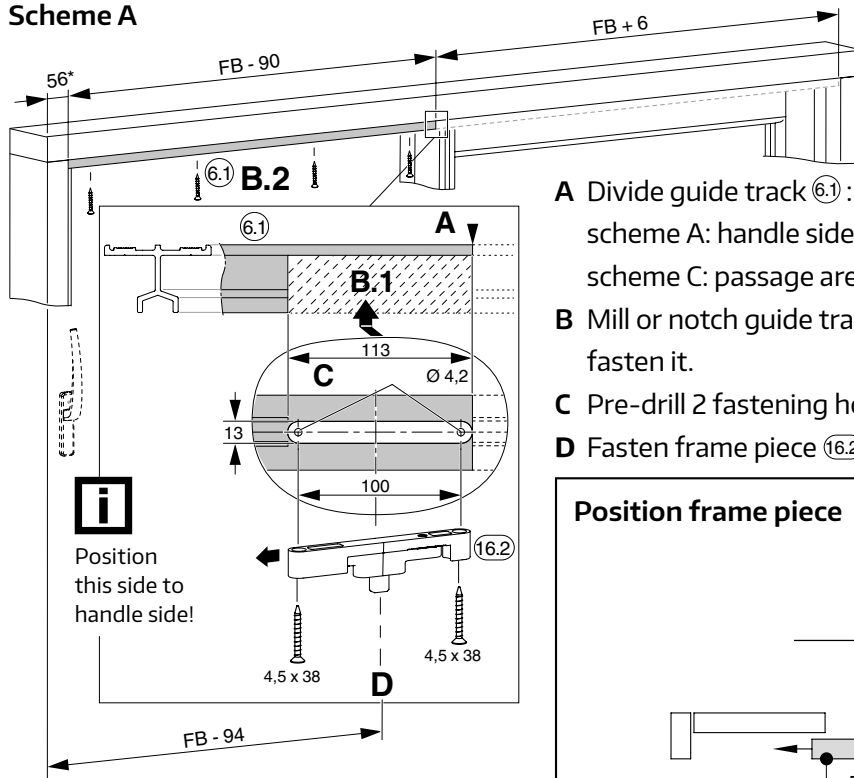

- A** Divide guide track (6.1):  
 scheme A: handle side: FB - 102 mm, fixed sash side: FB + 9.  
 scheme C: passage area: 2.FB - 194, fixed sash: FB + 11.
- B** Mill or notch guide track on handle side for frame piece and fasten it.
- C** Pre-drill 2 fastening holes  $\varnothing 4.2$ .
- D** Fasten frame piece (16.2).

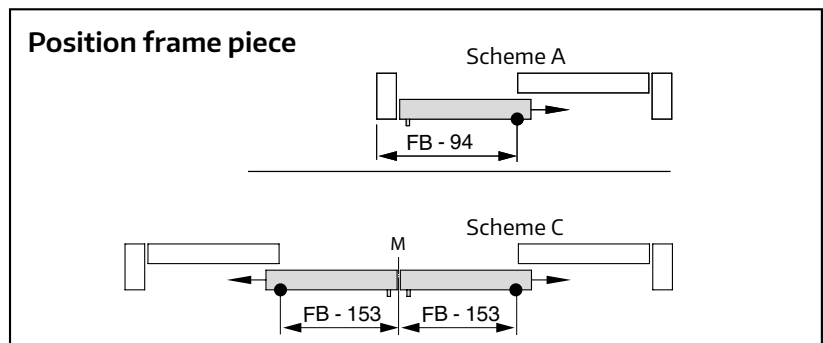

## Scheme C

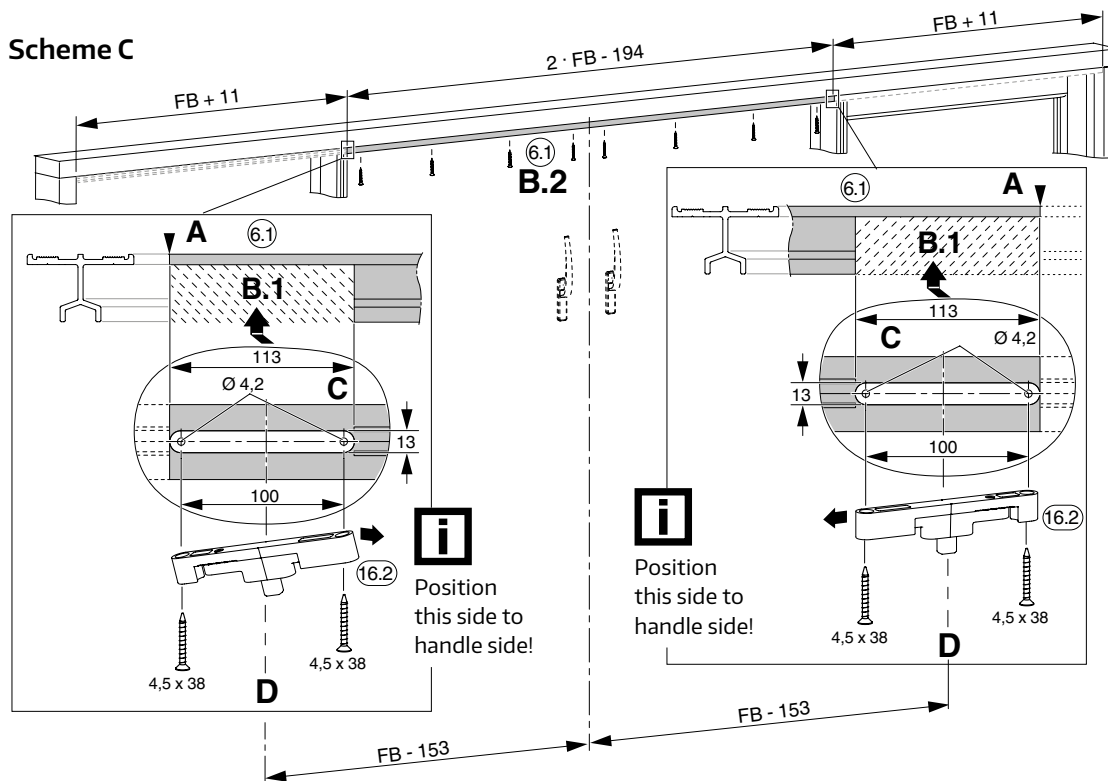

\*) based on 56 frame; in case of deviation, please contact MACO.

# Preparation sash

> Carry out sash milling for Comfort Close on non-handle side and/or for Comfort Stop on handle side.

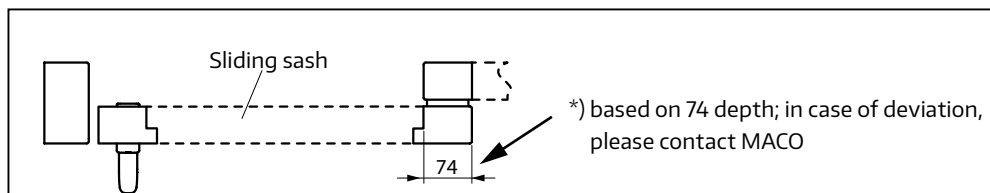
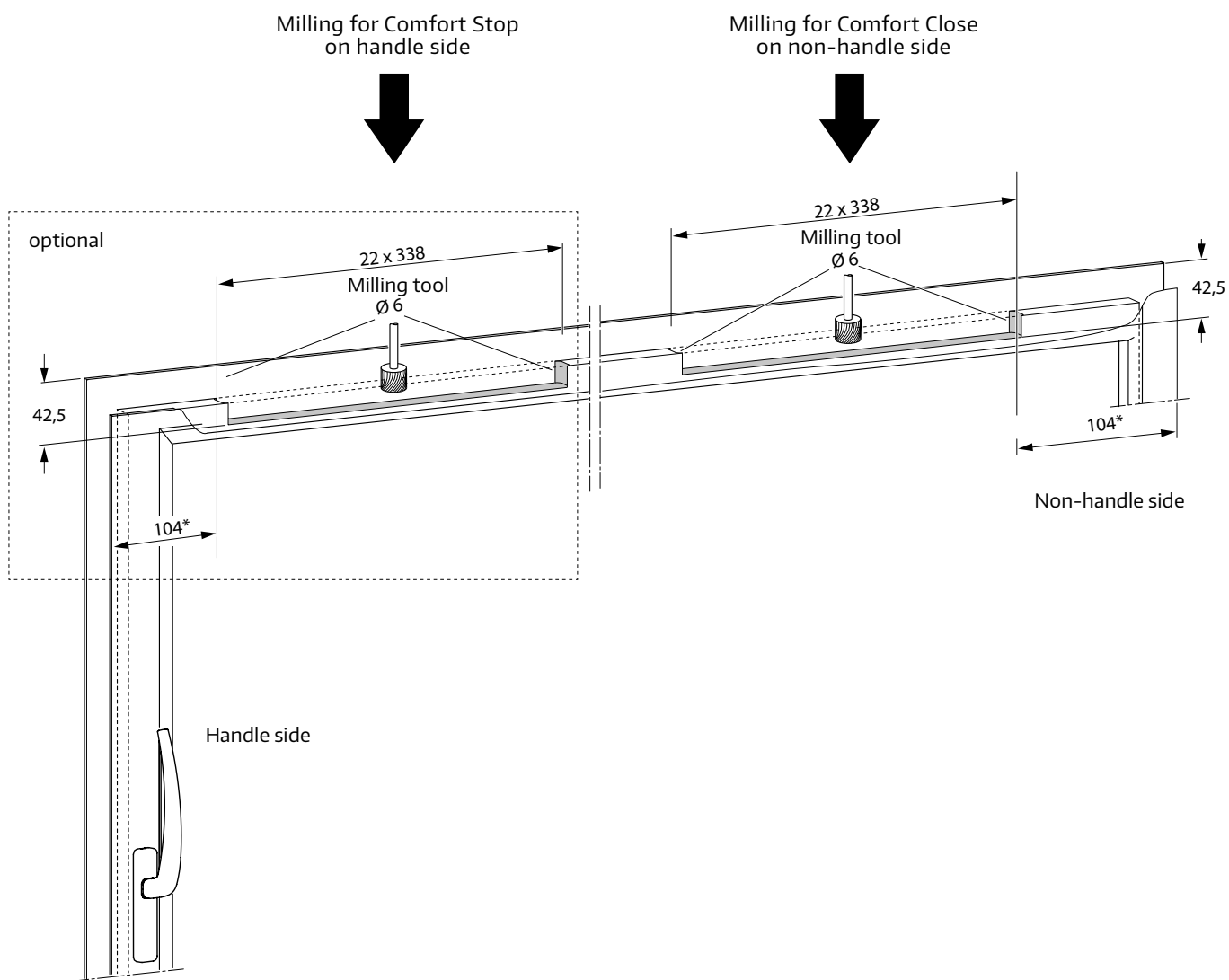

## Mounting Comfort Close/Comfort Stop

- > (1) Comfort Close respectively Comfort Stop has to be pretensioned.
- > (2) Mount the Comfort Close respectively Comfort Stop with 2 screws 4,5 x 25 each at the sash.

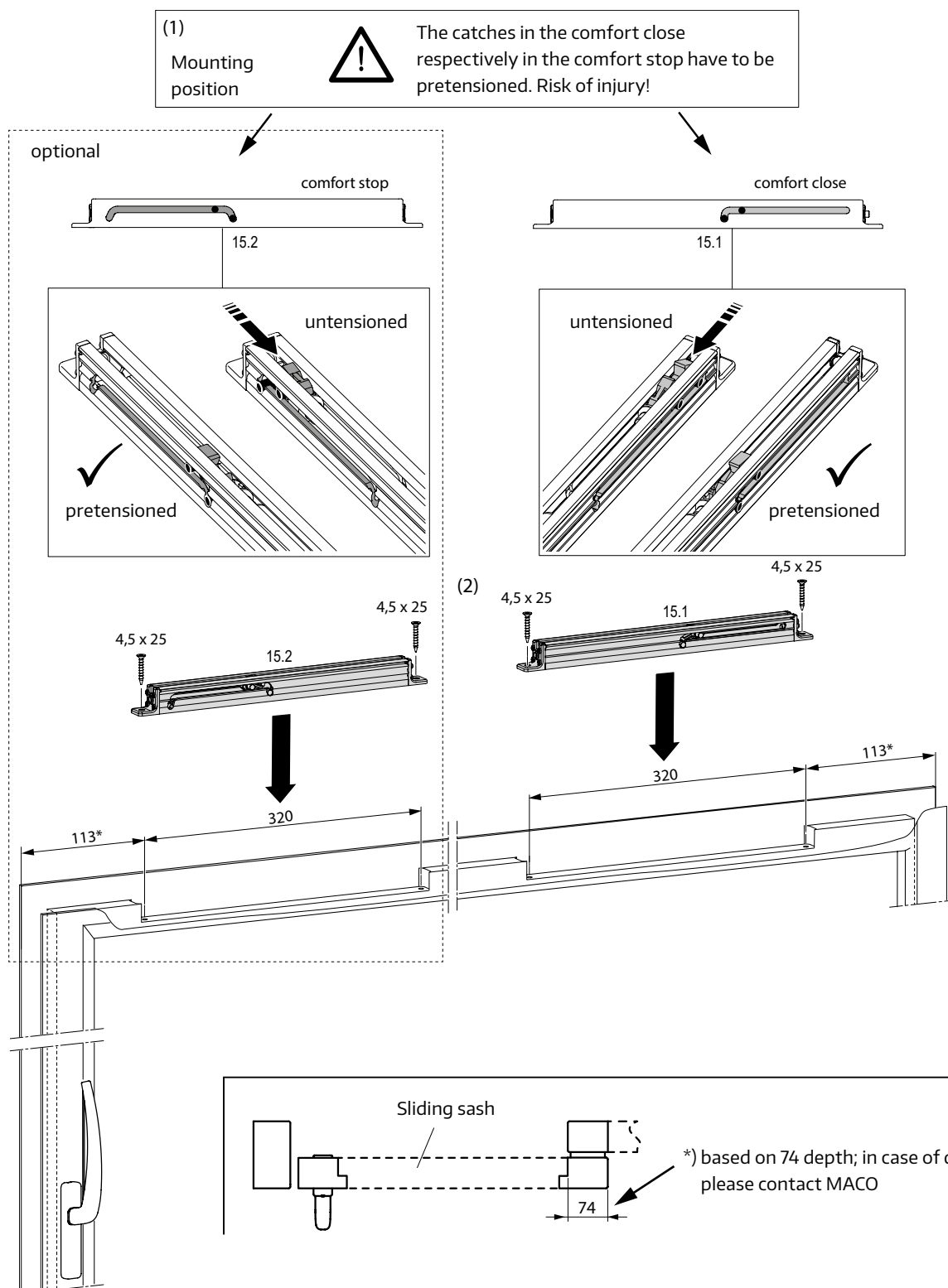

## Mounting sash and frame



**Attention:** Risk of injury due to fallen sash! To avoid the risk of injury, perform the following steps with two workers.

**A** Set down the sliding sash onto the running track in the area of the fixed sash and swivel it into the element.

**B** Bring handle into „Open“ position and slide the sliding sash to the transit area.

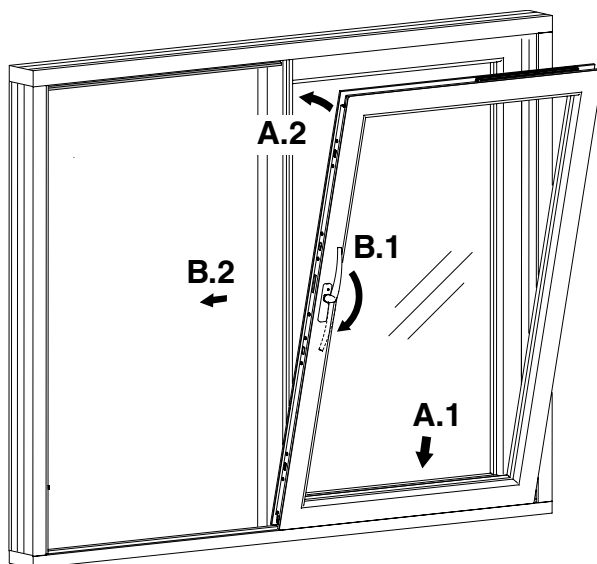

## Reference dimension

- › To check the height of the frame piece, swivel in the sash, lift it and slide into closing position.
- › Measure reference dimension within the range of the Comfort Close (desired value = 6 mm).
- › If necessary, push the sash to one side and adjust the frame part to compensate for the difference to the control dimension (see "Adjustment options").
- › Fasten guide track on fixed sash side.

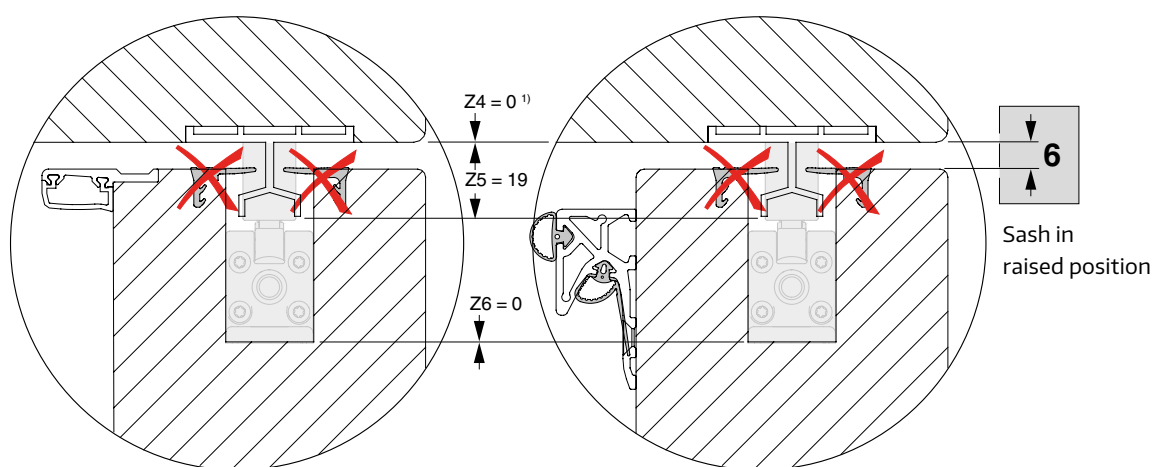

## Completion of guide track

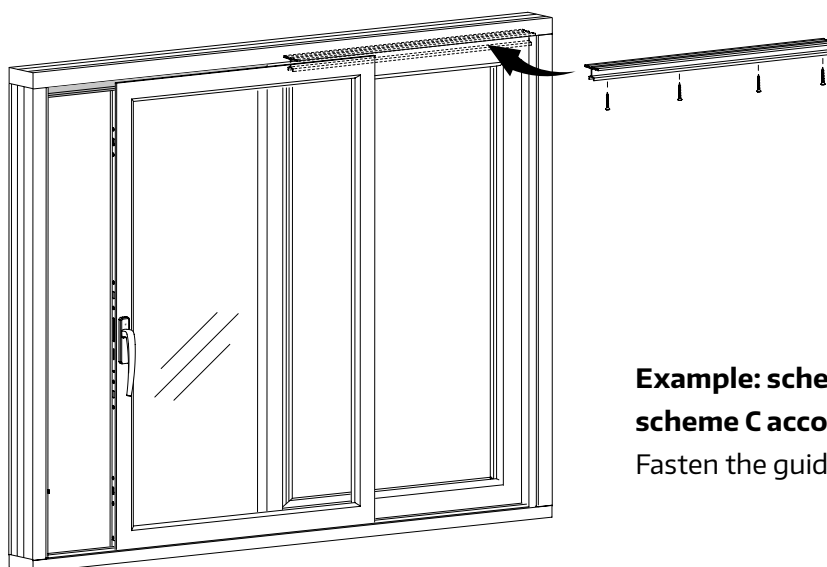

**Example: scheme A;  
scheme C accordingly**  
Fasten the guide track at frame profile.

## Adjustment options

In case of inaccuracy concerning position of the frame piece, the reference dimension concerning the height of the frame piece and the end position of the sash related to the frame can be adjusted.

To do this, the sash has to be opened.

- › (1) Correction of the lateral position (+/- 5 mm):
  - (1.1) Loosen screw by means of Torx 25,
  - (1.2) Slide frame piece into the desired direction:
    - 0 – 5 mm: closing of sash will be shifted in direction of handle side;
    - 0 + 5 mm: closing of sash will be shifted in direction of non-handle side
  - (1.3) Fasten screw with max. 3 Nm.
- › (2) Correction of the height of the frame piece (+ 3 mm) with Torx 15.

Adjustment at  
closing edge

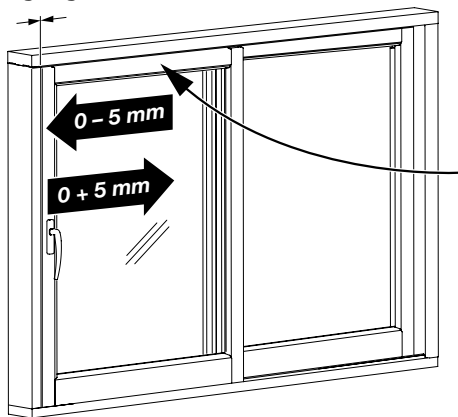

(Sash opened)

0 – 5 mm: towards closing position (frame)  
0 + 5 mm: off the closing position (frame)

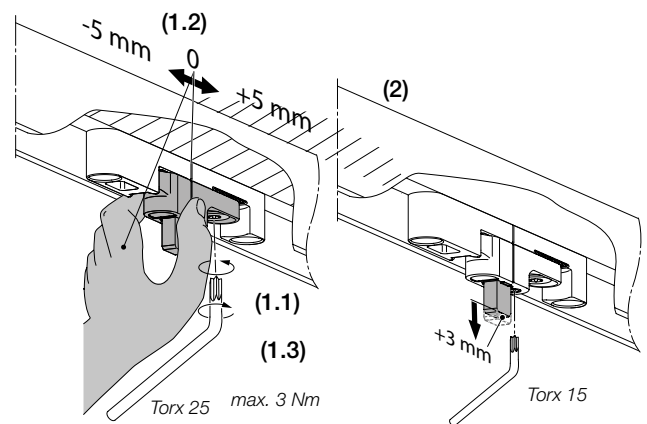

**Note: Adjustments may be changed after glazing the sash and mounting the frame!**

## Mounting cover frame piece

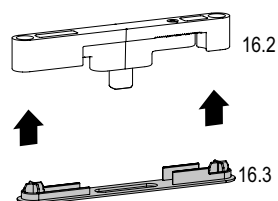



## Technical data

### Range of application scheme A:

Sash width (FB)	720 – 3385 mm
FB <sub>min.</sub> for 2x Comfort Close	885 mm
Sash height (FH)	745 – 2870 mm
Outer frame width (RAB)	6500 mm
Sash weight or sliding force without Comfort Close and Comfort Stop	size 1: max. 200 kg or max. 30 N size 2: max. 300 kg or max. 50 N (further sizes on request)

Depending on version of the profile sealing to be used, it can happen, that the sash cannot close completely.

Dimensions (W x H x D)	
Comfort Close	336 mm x 27.5 mm x 22 mm
Comfort Stop	336 mm x 27.5 mm x 22 mm
Soft move-in	starting approx. 100 mm off the closing edge
Increase of sliding force with Comfort Close or Comfort Stop	size 1: by 25 N (black) size 2: by 45 N (silver-grey)

Range of application is depending on used profile systems. Specifications of profile manufacturers to be observed.

# You want everything from a single source?

We provide you with complete solutions for sliding doors, windows and doors – for timber, PVC and aluminium. Experience our versatile system offer, comprehensive service included. Discover more of this on our website [www.maco.eu](http://www.maco.eu) or contact your MACO representative.

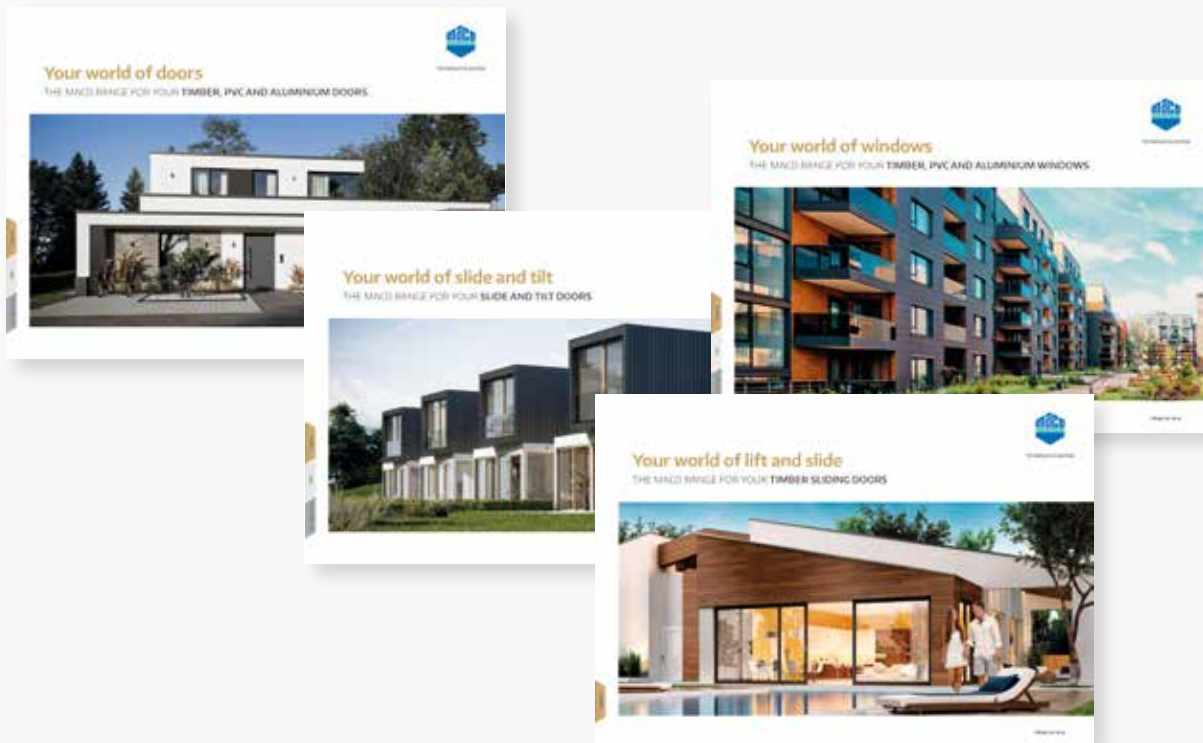

**MACO near you:**  
[www.maco.eu/contact](http://www.maco.eu/contact)



TECHNOLOGY IN MOTION



This print document is revised regularly.  
The latest version is available at <https://www.maco.eu/assets/757755>  
or by scanning the QR code.

Created: 02/2019 - Changed: 30.07.2020  
Order no. 757755  
All rights reserved and subject to change.